



US00D685683S

(12) **United States Design Patent**
Shaw et al.

(10) **Patent No.:** **US D685,683 S**

(45) **Date of Patent:** **** Jul. 9, 2013**

(54) **ELECTRIC BICYCLE**

(75) Inventors: **Richard Shaw**, Koengernheim (DE);
Pierre Olivier Garcia, Wiesbaden (DE)

(73) Assignee: **GM Global Technology Operations LLC**, Detroit, MI (US)

(**) Term: **14 Years**

(21) Appl. No.: **29/429,530**

(22) Filed: **Aug. 13, 2012**

(30) **Foreign Application Priority Data**

Feb. 16, 2012 (EM) 001993262

(51) **LOC (9) Cl.** **12-11**

(52) **U.S. Cl.**
USPC **D12/111**

(58) **Field of Classification Search**
USPC D12/111, 110, 117, 119; 280/274-280,
280/283-288, 288.1-288.4, 281.1, 210, 212,
280/214, 215, 230; 180/65.1, 65.29, 68.5,
180/205.1-205.7, 206.1-206.8, 207.1-207.3,
180/221-223, 311, 312, 228, 65.6-65.8,
180/65.31

See application file for complete search history.

(56) **References Cited**

U.S. PATENT DOCUMENTS

5,368,122 A *	11/1994	Chou	180/220
D406,253 S *	3/1999	Yamashita et al.	D12/110
6,039,137 A *	3/2000	Schless	180/220
D434,349 S *	11/2000	Currie et al.	D12/111
6,152,250 A *	11/2000	Shu-Hsien	180/220
6,276,479 B1 *	8/2001	Suzuki et al.	180/206.8
7,284,631 B2 *	10/2007	Rizzetto	180/206.4
D626,037 S *	10/2010	Thetard	D12/111
8,047,320 B2 *	11/2011	Hadley	180/206.5
D670,208 S *	11/2012	Frenzel et al.	D12/111

* cited by examiner

Primary Examiner — Susan M Lee

Assistant Examiner — Linda G Brooks

(74) *Attorney, Agent, or Firm* — Abelman, Frayne & Schwab

(57) **CLAIM**

The ornamental design for an electric bicycle, as shown and described.

DESCRIPTION

FIG. 1 is a right, front and side perspective view showing our new electric bicycle design;
FIG. 2 is a top plan view thereof;
FIG. 3 is a left-side view thereof;
FIG. 4 is a front elevational view thereof;
FIG. 5 is a right-side view thereof;
FIG. 6 is a rear elevational view thereof; and,
FIG. 7 is a bottom plan view thereof.
The broken lines illustrate unclaimed structure.

1 Claim, 7 Drawing Sheets

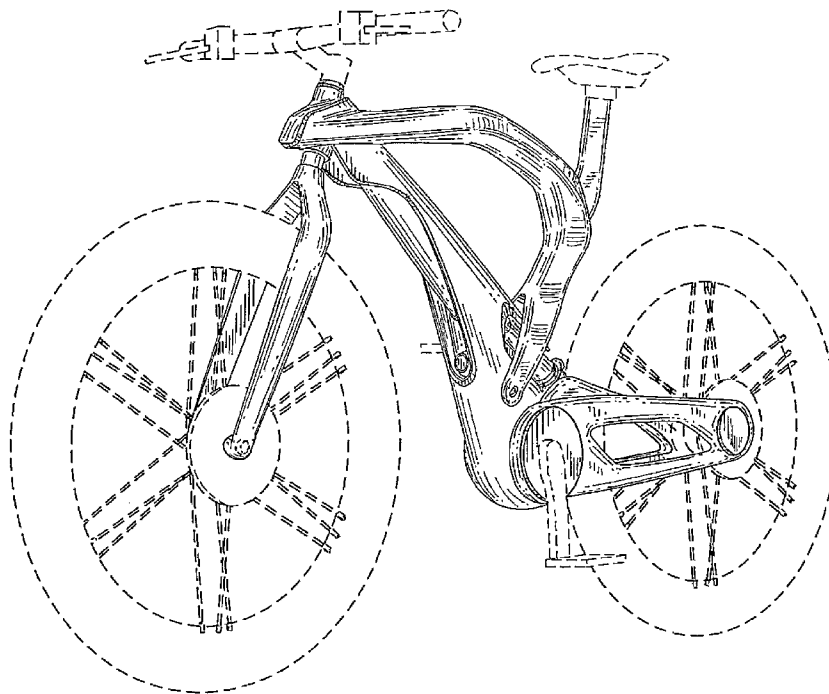

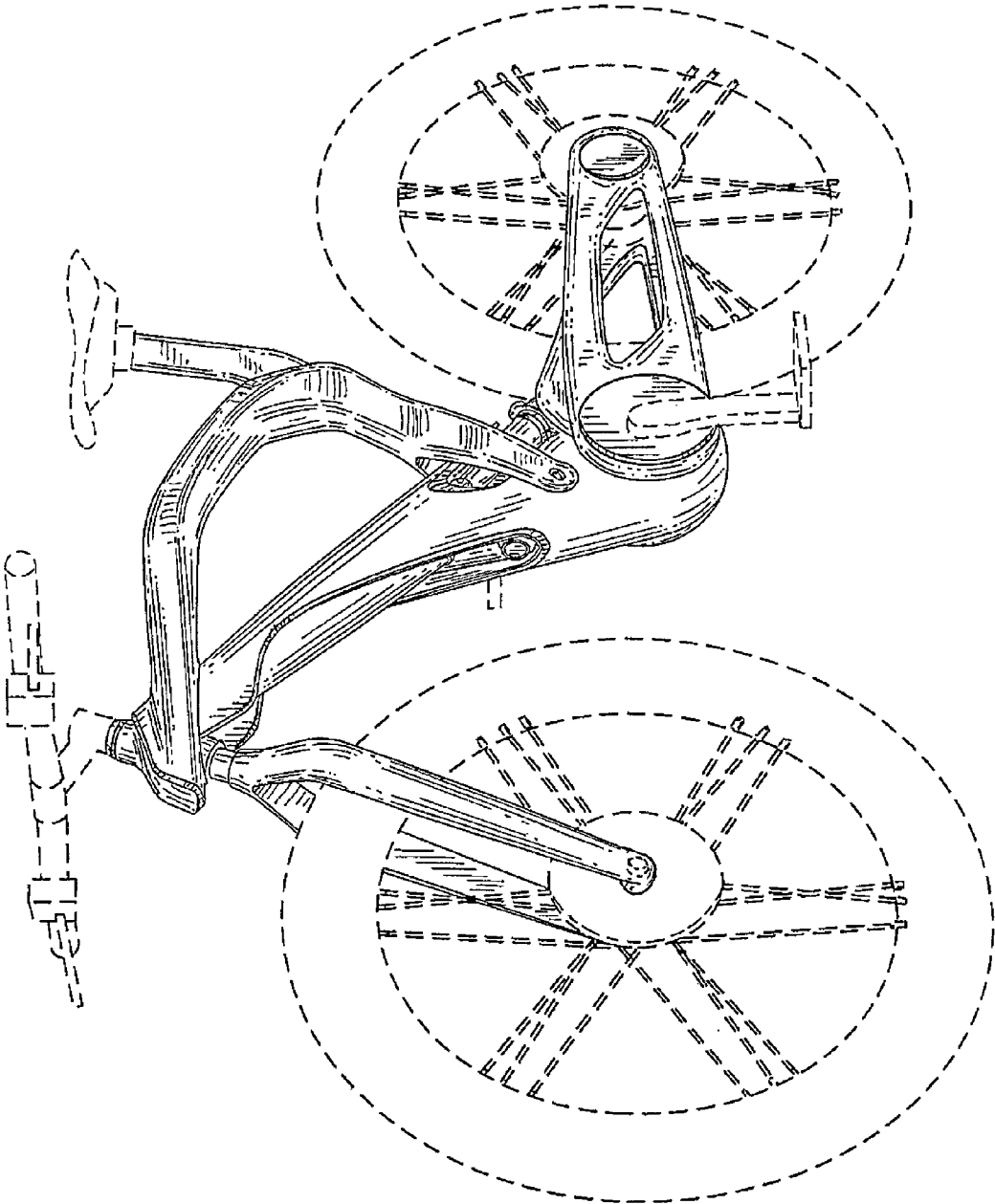

FIG. 1

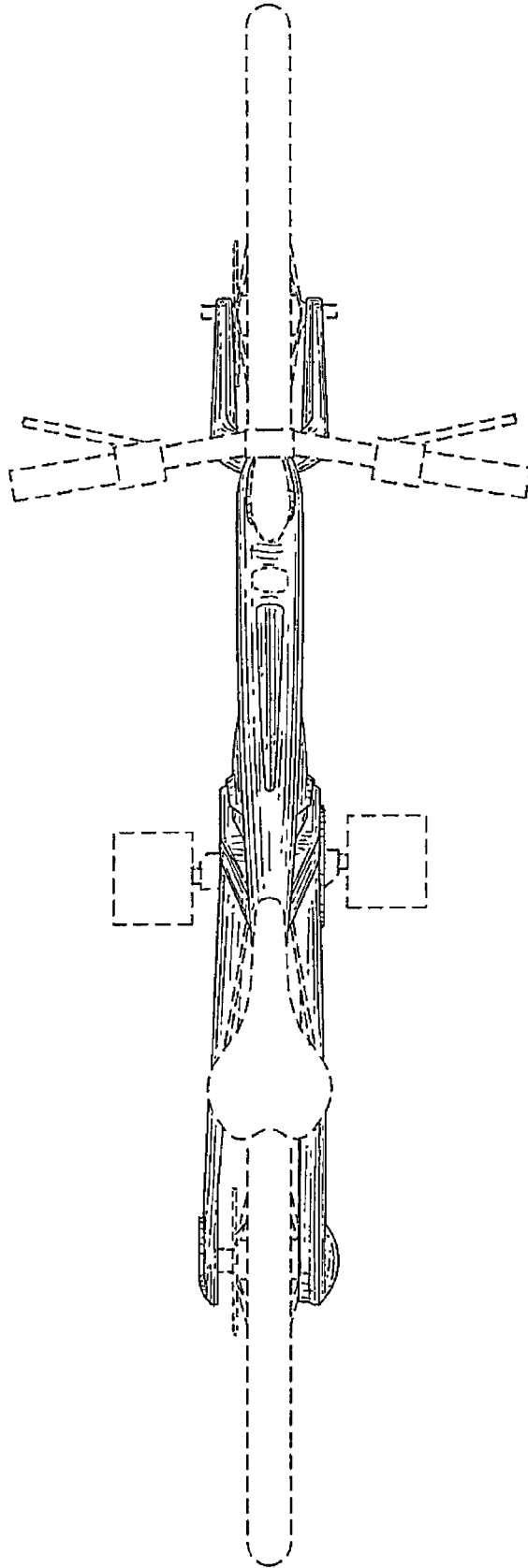
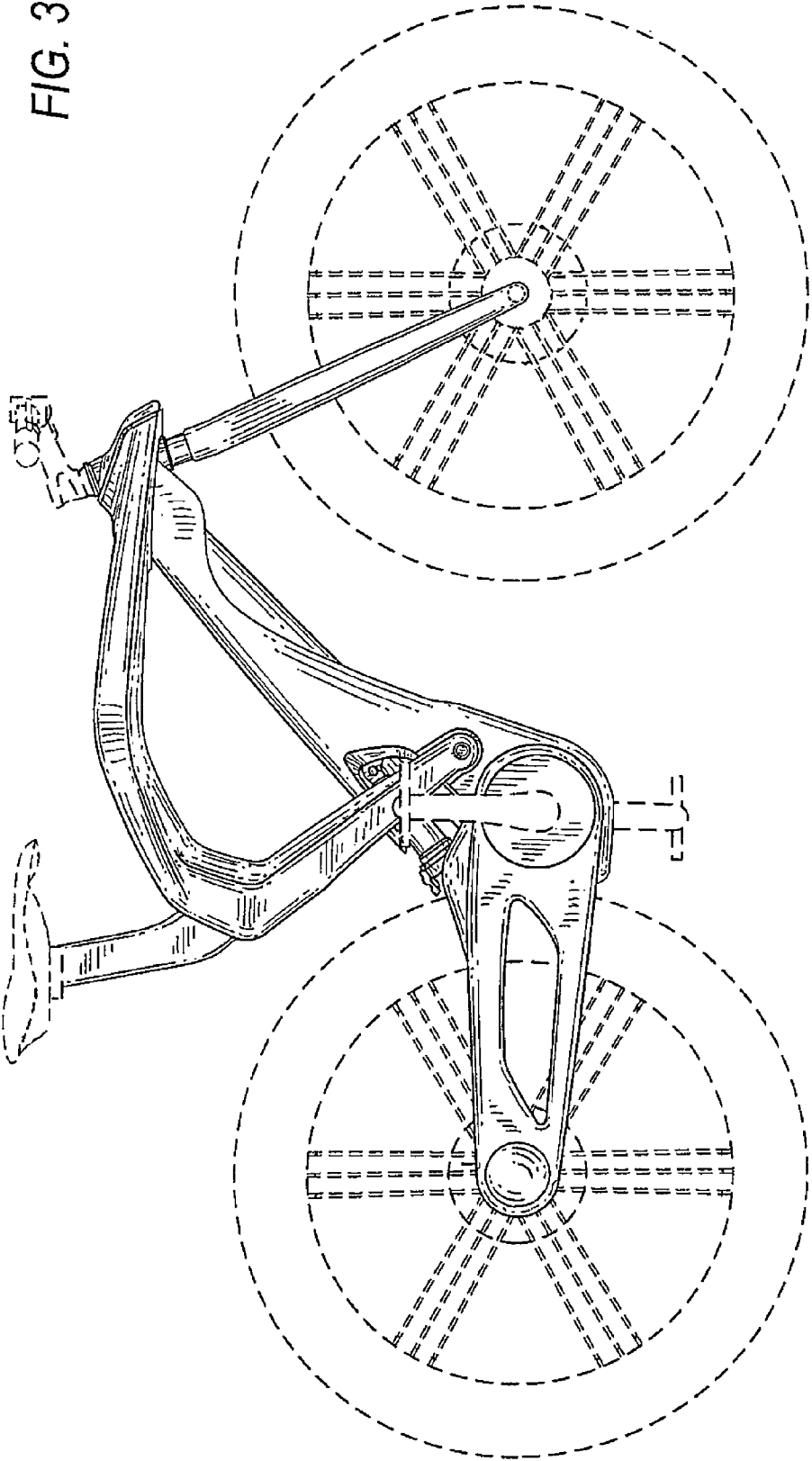

FIG. 2

FIG. 3



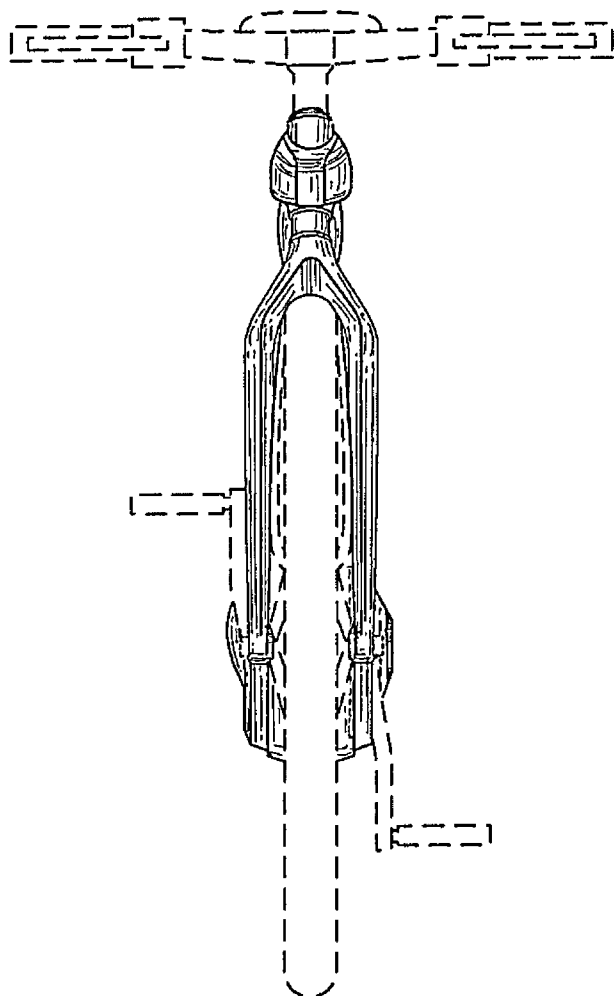

FIG. 4

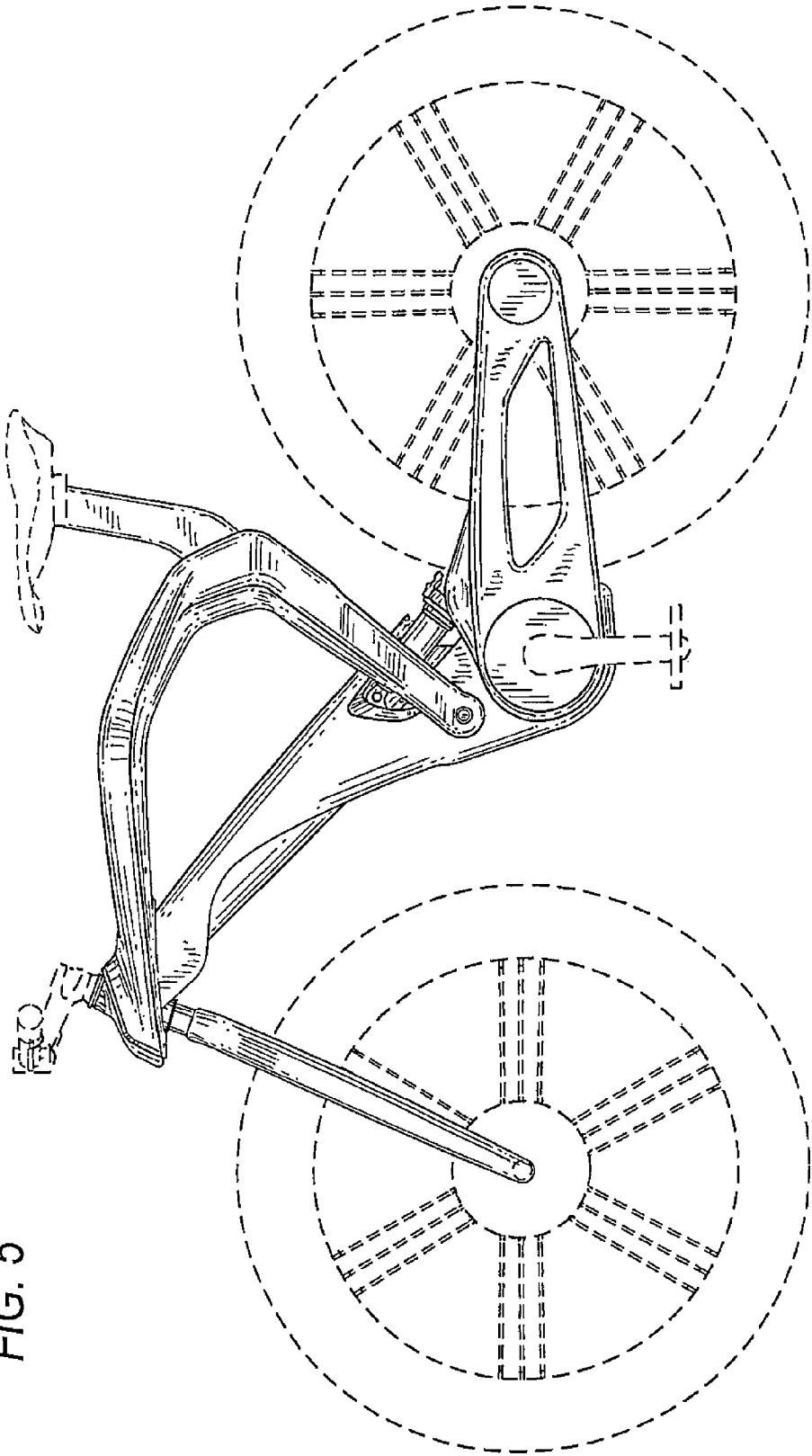

FIG. 5

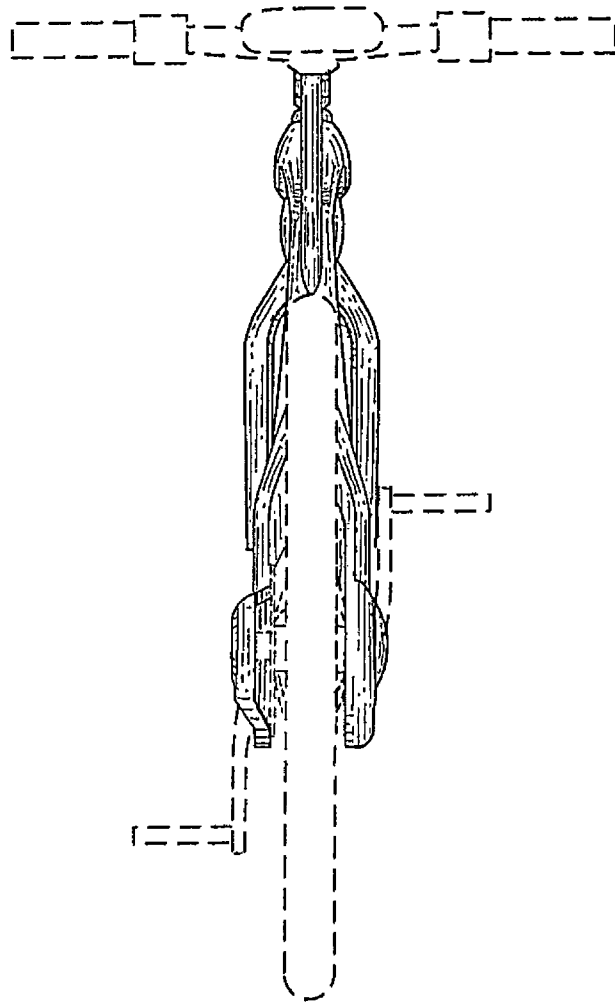

FIG. 6

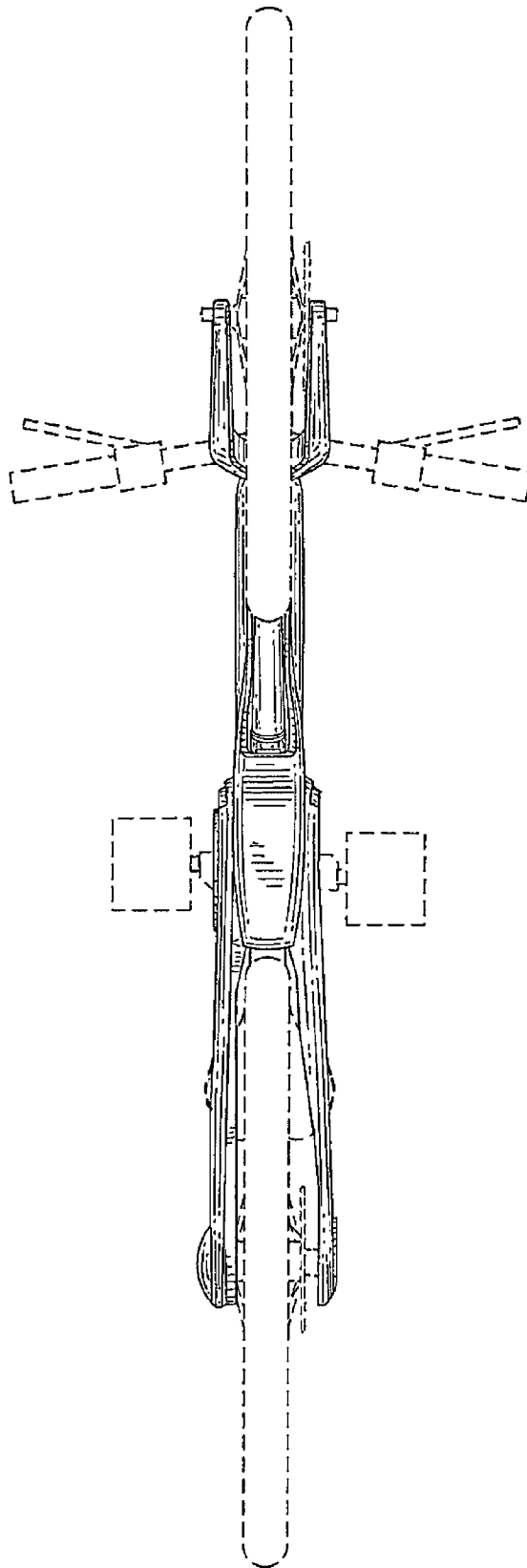

FIG. 7