



(51) International Patent Classification:

B65D 71/18 (2006.01) *B65D 71/06* (2006.01)
B65D 71/34 (2006.01) *B65D 81/05* (2006.01)

(21) International Application Number:

PCT/US2012/029022

(22) International Filing Date:

14 March 2012 (14.03.2012)

(25) Filing Language:

English

(26) Publication Language:

English

(30) Priority Data:

61/518,504 6 May 2011 (06.05.2011) US
61/572,638 19 July 2011 (19.07.2011) US
61/627,249 7 October 2011 (07.10.2011) US
61/548,779 19 October 2011 (19.10.2011) US
61/570,044 13 December 2011 (13.12.2011) US

(71) Applicant (for all designated States except US): **GRAPHIC PACKING INTERNATIONAL, INC.** [US/US]; 814 Livingston Court, Marietta, GA 30067 (US).

(72) Inventors; and

(75) Inventors/Applicants (for US only): **SCHMAL, Michael, R.** [US/US]; 1195 Regency Road NW, Atlanta, GA 30327 (US). **ALEXANDER, O'Neal** [US/US]; 235 Pebble Brooke Pass, Covington, GA 30016 (US). **BALDINO, Mark** [US/US]; 1967 LaSalle Way, Marietta, GA 30062 (US). **CERIO, Michael** [US/US]; 3013 Fairhaven Ridge NW, Kennesaw, GA 30144 (US). **HOLLEY, John,**

Murdick, Jr. [US/US]; 950 Brentwood Avenue, Lawrenceville, GA 30044 (US). **MONCRIEF, Frank, N.** [US/US]; 70 Chadd's Pointe, Acworth, GA 30101 (US). **KASTANEK, Raymond, S.** [US/US]; 1950 Barrett Lakes Blvd NW #1623, Kennesaw, GA 30144 (US). **FORD, Colin** [US/US]; 510 Old Field Cove, Woodstock, GA 30189 (US).

(74) Agent: **CLAERBOUT, Andrew, N.**; Womble Carlyle Sandridge & Rice, LLP, P.O. Box 7037, Atlanta, GA 30357-0037 (US).

(81) Designated States (unless otherwise indicated, for every kind of national protection available): AE, AG, AL, AM, AO, AT, AU, AZ, BA, BB, BG, BH, BR, BW, BY, BZ, CA, CH, CL, CN, CO, CR, CU, CZ, DE, DK, DM, DO, DZ, EC, EE, EG, ES, FI, GB, GD, GE, GH, GM, GT, HN, HR, HU, ID, IL, IN, IS, JP, KE, KG, KM, KN, KP, KR, KZ, LA, LC, LK, LR, LS, LT, LU, LY, MA, MD, ME, MG, MK, MN, MW, MX, MY, MZ, NA, NG, NI, NO, NZ, OM, PE, PG, PH, PL, PT, QA, RO, RS, RU, RW, SC, SD, SE, SG, SK, SL, SM, ST, SV, SY, TH, TJ, TM, TN, TR, TT, TZ, UA, UG, US, UZ, VC, VN, ZA, ZM, ZW.

(84) Designated States (unless otherwise indicated, for every kind of regional protection available): ARIPO (BW, GH, GM, KE, LR, LS, MW, MZ, NA, RW, SD, SL, SZ, TZ, UG, ZM, ZW), Eurasian (AM, AZ, BY, KG, KZ, MD, RU, TJ, TM), European (AL, AT, BE, BG, CH, CY, CZ, DE, DK, EE, ES, FI, FR, GB, GR, HR, HU, IE, IS, IT, LT, LU, LV, MC, MK, MT, NL, NO, PL, PT, RO, RS, SE, SI, SK,

[Continued on next page]

(54) Title: CARTON WITH ARTICLE PROTECTION FEATURE

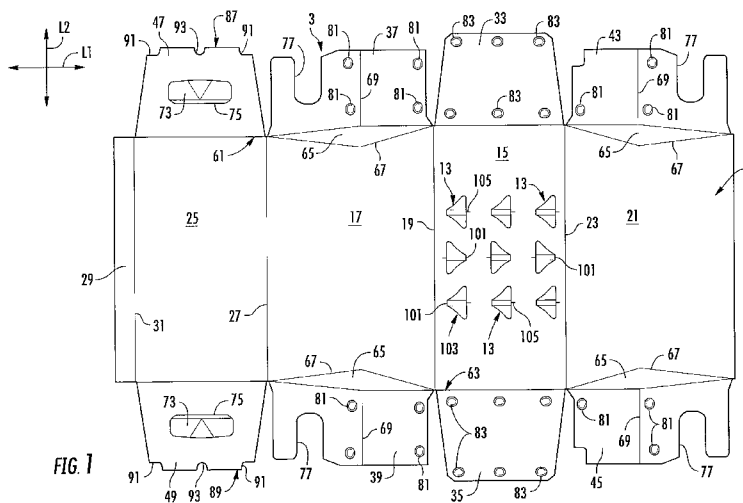

(57) Abstract: A carton for containing at least one article. The carton comprises at least one panel that can form an interior of the carton. The carton comprises at least one protection feature for protecting the articles from breakage. The article protection feature can comprise at least one feature in end flaps of the carton. The article protection feature can comprise an article protection flap foldably connected to the at least one panel. The article protection flap can be moveable between a first position and a second position wherein the article protection flap is folded relative to the at least one panel.

WO 2012/154297 A1

SM, TR), OAPI (BF, BJ, CF, CG, CI, CM, GA, GN, GQ, — *before the expiration of the time limit for amending the
GW, ML, MR, NE, SN, TD, TG). claims and to be republished in the event of receipt of
amendments (Rule 48.2(h))*

Published:

— *with international search report (Art. 21(3))*

CARTON WITH ARTICLE PROTECTION FEATURE

Cross-Reference to Related Applications

[0001] This application claims the benefit of U.S. Provisional Application No. 61/518,504, filed May 6, 2011, U.S. Provisional Application No. 61/572,638, filed July 19, 2011, U.S. Provisional Application No. 61/272,249, filed October 7, 2011, U.S. Provisional Application No. 61/548,779, filed October 19, 2011, and U.S. Provisional Application No. 61/570,044, filed December 13, 2011.

Incorporation By Reference

[0002] The entire contents of U.S. Provisional Application No. 61/518,504, filed May 6, 2011, U.S. Provisional Application No. 61/572,638, filed July 19, 2011, U.S. Provisional Application No. 61/272,249, filed October 7, 2011, U.S. Provisional Application No. 61/548,779, filed October 19, 2011, and U.S. Provisional Application No. 61/570,044, filed December 13, 2011, are hereby incorporated by reference as if presented herein in their entirety.

Background of the Disclosure

[0003] The present disclosure generally relates to cartons for holding beverage containers or other types of articles. More specifically, the present disclosure relates to cartons having an article protection feature and/or article protection flap that protects the containers or articles from breakage.

Summary of the Disclosure

[0004] In general, one aspect of the disclosure is directed to a carton for containing at least one article. The carton comprises at least one panel at least partially forming an interior of the carton. At least one article protection flap is for protecting the at least one article. The at least one article protection flap is foldably connected to the at least one panel and moveable between a first position that is substantially parallel to the at least one panel and a second position wherein the article protection flap is folded relative to

the at least one panel. The article protection flap has features for preventing folding of the article protection flap from the second position to the first position.

[0005] In another aspect, the disclosure is generally directed to a blank for forming a carton for containing at least one article. The blank comprises at least one panel for at least partially forming an interior of the carton formed from the blank. At least one article protection flap is for protecting the at least one article. The at least one article protection flap is foldably connected to the at least one panel and moveable between a first position that is substantially parallel to the at least one panel and a second position wherein the article protection flap is folded relative to the at least one panel. The article protection flap has features for preventing folding of the article protection flap from the second position to the first position in the carton formed from the blank.

[0006] In another aspect, the disclosure is generally direct to a method of forming a carton. The method comprises obtaining a blank comprising at least one panel and at least one article protection flap foldably connected to the at least one panel. The method comprises positioning the at least one panel to at least partially form an interior space of the carton, loading at least one article in the interior space, and folding the at least one article protection flap relative to the at least one panel after the loading the at least one article. The folding comprises moving the article protection flap from a first position that is substantially parallel to the at least one panel to a second position wherein the article protection flap is folded relative to the at least one panel.

[0007] In another aspect, the disclosure is generally directed to a carton for containing at least one article. The carton comprises a plurality of panels that extends at least partially around an interior of the carton. At least two end flaps are respectively foldably connected to respective panels of the plurality of panels. The end flaps are for being at least partially overlapped to close an end of the carton. At least one article protection feature is for protecting the at least one article. The at least one article protection feature is positioned between the at least two end flaps.

[0008] In another aspect, the disclosure is generally directed to a blank for forming a carton for containing at least one article. The blank comprises a plurality of panels for extending at least partially around an interior of the carton formed from the blank. At least two end flaps respectively foldably connected to respective panels of the plurality of

panels. The end flaps are for being at least partially overlapped to close an end of the carton formed from the blank. At least one article protection feature is for protecting the at least one article. The at least one article protection feature is for being positioned between the at least two end flaps.

[0009] In another aspect, the disclosure is generally directed to a method of forming a carton for containing at least one article. The method comprises obtaining a blank comprising a plurality of panels and at least two end flaps respectively foldably connected to a respective panel of the plurality of panels. The method comprises positioning the plurality of panels to form an interior space of the carton, loading at least one article in the interior space, at least partially overlapping the at least two end flaps to close an end of the carton, and forming an article protection feature that is positioned between the at least two end flaps.

[0010] In another aspect, the disclosure is generally directed to a method of forming a carton. The method comprises obtaining a blank comprising a panel and at least one article protection flap foldably connected to the panel. The method comprises positioning at least two articles to be in contact with the panel and folding the at least one article protection flap relative to the panel after the positioning the at least two articles. The folding comprises moving the article protection flap from a first position that is substantially parallel to the panel to a second position wherein the article protection flap is folded relative to the panel.

[0011] In another aspect, the disclosure is generally directed to a carton for containing at least one article. The carton comprises at least one panel at least partially forming an interior of the carton. At least two end flaps are at least partially overlapped to at least partially close the interior of the carton. At least one article protection feature is for protecting the at least one article. The at least one article protection feature is positioned between the at least two end flaps. At least one article protection flap is for protecting the at least one article. The at least one article protection flap is foldably connected to the at least one panel and is moveable between a first position that is substantially parallel to the at least one panel and a second position wherein the article protection flap is folded relative to the at least one panel.

[0012] In another aspect, the disclosure is generally directed to a method of forming a carton. The method comprises obtaining a blank comprising at least one panel, at least one article protection flap foldably connected to the at least one panel, and at least two end flaps. The method comprises positioning the at least one panel to at least partially form an interior space of the carton, loading at least one article in the interior space, at least partially overlapping the at least two end flaps to close an end of the carton, forming an article protection feature that is positioned between the at least two end flaps, and folding the at least one article protection flap relative to the at least one panel after the loading the at least one article. The folding comprises moving the article protection flap from a first position that is substantially parallel to the at least one panel to a second position wherein the article protection flap is folded relative to the at least one panel.

[0013] In another aspect, the present disclosure is generally directed to a carton having at least one protection feature.

[0014] In another aspect, the present disclosure is generally directed to a blank for forming a carton having at least one protection feature.

[0015] In another aspect, the present disclosure is generally directed to a method of forming a carton having at least one protection feature for protecting articles held in the carton from breakage.

[0016] Other aspects, features, and details of the present disclosure can be more completely understood by reference to the following detailed description of exemplary embodiments taken in conjunction with the drawings and from the appended claims.

[0017] Those skilled in the art will appreciate the above stated advantages and other advantages and benefits of various additional embodiments reading the following detailed description of the embodiments with reference to the below-listed drawing figures. Further, the various features of the drawings discussed below are not necessarily drawn to scale. Dimensions of various features and elements in the drawings may be expanded or reduced to more clearly illustrate the embodiments of the disclosure.

Brief Description of the Drawings

- [0018] Fig. 1 is a plan view of an exterior surface of a blank for forming a carton according to a first embodiment of the disclosure.
- [0019] Fig. 2 is an end perspective of the partially assembled carton of the first embodiment.
- [0020] Fig. 3 is an end view similar to Fig. 2 with articles added to the partially assembled carton.
- [0021] Fig. 4 is a view similar to Fig. 3 but showing the carton further assembled.
- [0022] Fig. 4A is a view similar to Fig. 4 but showing alternative features of the carton.
- [0023] Fig. 5 is an enlarged portion view of Fig. 4.
- [0024] Fig. 5A is a view similar to Fig. 5 but showing alternative features of the carton.
- [0025] Fig. 5B is a cross-section taken along the plane 5B-5B of Fig. 5A.
- [0026] Fig. 5C is a view similar to Fig. 5 but showing alternative features of the carton.
- [0027] Fig. 6 is a side perspective showing the carton of Fig. 5 further assembled.
- [0028] Fig. 7 is an end view showing the carton of Fig. 6 further assembled.
- [0029] Fig. 8 is an end view showing the carton further assembled.
- [0030] Fig. 8A is an end view of a partially assembled carton of the first embodiment with the article protection flaps in the second position.
- [0031] Fig. 9 is a cross-section taken along the plane 9-9 of Fig. 8.
- [0032] Fig. 9A is a cross-section taken along the plane 9A-9A of Fig. 8.
- [0033] Fig. 9B is a view similar to Fig. 9 but showing alternative features of the carton.
- [0034] Fig. 9C is a view similar to Fig. 9A but showing alternative features of the carton.

[0035] Fig. 10A is a top plan view of an enlarged portion of a bottom panel of Fig. 1 showing an article protection flap in a first position.

[0036] Fig. 10B is a top plan view of the article protection flap of Fig. 10A in a second position.

[0037] Fig. 10C is a cross-section taken along the plane 10C-10C of Fig. 10B.

[0038] Fig. 10D is a view similar to Fig. 10A but showing alternative features of the article protection flap.

[0039] Fig. 10E is a view similar to Fig. 10B but showing the article protection flap of Fig. 10D.

[0040] Fig. 10F is a cross-section taken along the plane 10F-10F of Fig. 10E.

[0041] Fig. 11 is a plan view of a system for activating the article protection flaps of one embodiment of the disclosure.

[0042] Fig. 12 is an enlarged portion of Fig. 11.

[0043] Fig. 13 is a partial schematic view of a system for activating the article protection flaps of an alternative embodiment of the disclosure.

[0044] Fig. 14 is a partial schematic view of a system for activating the article protection flaps of an alternative embodiment of the disclosure.

[0045] Fig. 15 is a plan view of a blank for forming a carton according to an alternative embodiment of the disclosure.

[0046] Fig. 16 is a plan view of a blank for forming a carton according to an alternative embodiment of the disclosure.

[0047] Fig. 17 is a plan view of a blank for forming a carton according to an alternative embodiment of the disclosure.

[0048] Fig. 17A is an enlarged portion of the bottom panel of Fig. 17 showing an article protection flap.

- [0049] Fig. 18 is a plan view of a bottom panel of the carton of the embodiment of Fig. 17 with the article protection flaps in a second position.
- [0050] Fig. 19 is an end view of a partially assembled carton of the embodiment of Fig. 17 with the article protection flaps in the second position.
- [0051] Fig. 20 is a plan view of a blank for forming a carton according to an alternative embodiment of the disclosure.
- [0052] Fig. 20A is an enlarged portion of the bottom panel of Fig. 20 showing an article protection flap.
- [0053] Fig. 21 is a plan view of an exterior surface of a bottom panel of a carton according to an alternative embodiment of the disclosure with articles contained in the carton shown in hidden lines.
- [0054] Fig. 22 is a perspective view of an interior surface of the bottom panel of the carton of the embodiment of Fig. 21 showing article protection flaps.
- [0055] Fig. 23 is a perspective view of the interior surface of the bottom panel of the carton of the embodiment of Fig. 21 showing the article protection flaps in a second position.
- [0056] Fig. 24 is a plan view of an exterior surface of a blank for forming a carton according to an alternative embodiment of the disclosure.
- [0057] Figs. 25-27 are various views of forming the carton according to the embodiment of Fig. 24.
- [0058] Fig. 27A is a cross-section taken along the plane 27A-27A of Fig. 27.
- [0059] Fig. 27B is a cross-section taken along the plane 27B-27B of Fig. 27.
- [0060] Fig. 28 is a plan view of an exterior surface of a blank for forming a carton according to an alternative embodiment of the disclosure.
- [0061] Fig. 29 is a plan view of an exterior surface of a blank for forming a carton according to an alternative embodiment of the disclosure.

- [0062] Fig. 30 is a perspective view of a carton according to the embodiment of Fig. 29.
- [0063] Figs. 31A-31C are various views of a blank and carton according to an alternative embodiment.
- [0064] Figs. 32A-32C are various views of a blank and carton according to an alternative embodiment.
- [0065] Figs. 33A-33C are various views of a blank and carton according to an alternative embodiment of the disclosure.
- [0066] Corresponding parts are designated by corresponding reference numbers throughout the drawings.

Detailed Description of the Exemplary Embodiments

- [0067] The present disclosure generally relates to cartons that contain a single article or a plurality of articles such as containers, bottles, cans, etc., and protection features of such cartons that protect the article or articles or containers from breakage, damage, or deformation. The article(s) can be used for packaging food and beverage products, for example, or any other item. The article(s) can be made from materials suitable in composition for packaging the particular food or beverage item, or other item, and the materials can include, but are not limited to, glass or other breakable material; aluminum and/or other metals; plastics such as PET, LDPE, LLDPE, HDPE, PP, PS, PVC, EVOH, and Nylon; paperboard; and the like, or any combination thereof, or any other suitable material.
- [0068] Cartons according to the present disclosure can accommodate articles of any shape. For the purpose of illustration and not for the purpose of limiting the scope of the disclosure, the following detailed description describes beverage containers (e.g., glass beverage bottles) as disposed within the carton embodiments. In this specification, the terms “lower,” “bottom,” “upper” and “top” indicate orientations determined in relation to fully erected and upright cartons.
- [0069] Fig. 1 is a plan view of the exterior side 1 of a blank, generally indicated at 3, used to form a carton 5 (Fig. 8) according to a first exemplary embodiment of the disclosure. The carton 5 can be used to house a plurality of articles such as containers C

(Fig. 3). In the illustrated embodiment, the containers C are bottles having a wide bottom B and a narrow top T including a cap CP. In the illustrated embodiment, the carton 5 is sized to house eighteen containers C in a single layer in a 3x6 arrangement, but it is understood that the carton 5 may be sized and shaped to hold containers of a different or same quantity in more than one layer and/or in different row/column arrangements (e.g., 1x6, 2x6, 4x6, 3x8, 2x6x2, 3x4x2, 2x9, 3x4, etc.), or just a single article.

[0070] In one embodiment, the carton 5 has a first end 7 and a second end 9 each having article protection features 11, 11A, 11B (Fig. 8) for protecting at least one article C of the plurality of articles. Alternatively, only a single article C could be provided in the carton 5. As will be further discussed below, the carton 5 of the first embodiment may have article protection flaps 13 for protecting the at least one article. The article protection features 11 cushion the ends 7, 9 of the carton and prevent or reduce the likelihood of breakage of the containers C. In one embodiment, the article protection flaps 13 are moveable between a first position (Fig. 10A) and a second position (Figs. 8A and 10B) placed between adjacent containers C in the carton to reduce movement of the containers in the carton and prevent breakage of the containers. The carton 5 can have other features (e.g., handle, dispenser, etc.) without departing from the disclosure.

[0071] The blank 3 has a longitudinal axis L1 and a lateral axis L2. In the embodiment of Fig. 1, the blank includes a bottom panel 15 foldably connected to a first side panel 17 at a lateral fold line 19. A second side panel 21 is foldably connected to the bottom panel 15 at a lateral fold line 23. A top panel 25 is foldably connected to the first side panel 17 at a lateral fold line 27, and foldably connected to an adhesive panel 29 at a lateral fold line 31.

[0072] The bottom panel 15 is foldably connected to a first bottom end flap 33 and a second bottom end flap 35. The first side panel 17 is foldably connected to a first side end flap 37 and a second side end flap 39. The second side panel 21 is foldably connected to a first side end flap 43 and a second side end flap 45. The top panel 25 is foldably connected to a first top end flap 47 and a second top end flap 49. In one embodiment, when the carton 5 is erected, the end flaps 33, 37, 43, 47, close the first end 7 of the carton, and the end flaps 35, 39, 45, 49 close the second end 9 of the carton. In

accordance with an alternative embodiment of the present disclosure, different flap arrangements can be used for closing the ends 7, 9 of the carton 5.

[0073] The end flaps 33, 37, 43, 47 extend along a first marginal area of the blank 3, and are foldably connected at a first longitudinal fold line 61 that extends along the length of the blank. The end flaps 35, 39, 45, 49 extend along a second marginal area of the blank 3, and are foldably connected at a second longitudinal fold line 63 that also extends along the length of the blank. The longitudinal fold lines 61, 63 may be, for example, substantially straight, or offset at one or more locations to account for blank thickness or for other factors. In one embodiment, the side panels 17, 21 have respective diamond panels 65 that are formed by a fold line 67 that is spaced inwardly from the respective longitudinal fold line 61, 63. Also, the side end flaps 37, 39, 43, 45 have a respective lateral fold line 69 extending from a diamond panel 65 to allow a respective end 7, 9 to angle inwardly so that the top of the carton 5 at each end (the portion of the fold line 61, 63 connecting the top end flap 47, 49) is closer to the center of the carton than the bottom of the carton at each end (the portion of the fold line 61, 63 connecting the bottom end flap 33, 35). In this way, the ends 7, 9 are tapered ends, but it is understood that the ends of the carton 5 could be otherwise shaped, arranged, and/or configured (e.g., straight or non-tapered) without departing from the disclosure.

[0074] In the embodiment of Fig. 1, the blank 3 has handle features for forming a handle 71. In the illustrated embodiment, the handle features comprise handle flaps 73 foldably connected to a respective top end flap 47, 49 at a longitudinal fold line 75, and notches or openings 77 in the side end flaps 37, 39, 43, and 45. The openings 77 cooperate to provide an opening at a respective closed end 7, 9 to allow a respective handle flap 73 to be inwardly folded so that the carton 5 can be grasped at a respective end. The blank 3 can have other features for forming the handle 71, or the blank and/or carton 5 can have a handle that is alternatively shaped, arranged, and/or configured without departing from the disclosure. Further, the handle 71 can be omitted without departing from the disclosure.

[0075] In one embodiment, the blank 3 has features for forming the article protection features 11 of the carton 5. As shown in Fig. 1, the side end flaps 37, 39, 43, 45 have deformations in the form of indentations 81 on the exterior surface of the blank 3 such

that the indentations from a protrusion on the interior surface of the blank. The bottom end flap 33, 35 each have two rows of deformations in the form of indentations 83 on the interior surface of the blank 3 such that the indentations on the interior surface form a protrusion on the exterior surface 1 of the blank 3. As shown in Fig. 1, the top end flaps 47, 49 each have a respective distal edge 87, 89 having corner notches 91 and a center notch 93. The indentations 81, 83 can be any deformation on a surface of a respective side end flaps 37, 39, 43, 45 or bottom end flap 33, 35 such that the deformation can be any suitable shape (e.g., a concave depression or protrusion, convex depression or protrusion, flat depression or protrusion, embossed area, debossed area, etc., or any other suitable shape). Furthermore, the indentations 81, 83 could be formed on the interior or exterior surface of one or more of the first side panel 17, second side panel 21, top panel 25, bottom panel 15, or top end flaps 47, 49 without departing from the disclosure.

[0076] In the first embodiment, the blank 3 includes nine article protection flaps 13 arranged in a 3x3 arrangement, but the blank could have more or less than nine article protection flaps, and the flaps could be otherwise arranged in other suitable row/column arrangements or in a random configuration on the bottom panel 15, including a single row or single column configuration, or any other suitable configuration. The description herein will describe the detailed arrangement and configuration of a single article protection flap 13; however, the arrangement and configuration of the other article protection flaps will be similar or identical. In other embodiments, the blank 3 can include article protection flaps that are different, similar, or identical to other article protection flaps without departing from the disclosure. In the embodiment of Fig. 1, the middle row of article protection flaps 13 are oriented 180 degrees relative to a row of article protection flaps that are closer to a respective fold line 61, 63. In other embodiments, the article protection flaps 13 could be otherwise shaped, arranged, and/or configured without departing from the disclosure.

[0077] As shown in Figs. 1 and 10A, the article protection flaps 13 are each foldably connected to the bottom panel 15 at a respective lateral fold line 101 and are each at least partially defined by a line of weakening 103 in the bottom panel. In one embodiment, the line of weakening 103 is a cut, but the line of weakening could comprises other forms of weakening (e.g., a tear line that comprises cut lines separated by breakable nicks, a tear line that is formed by a series of spaced apart cuts, etc.) that allows the article protection

flap 13 to separate from the bottom panel 15 without departing from the disclosure. The cut 103 has a first portion 105 that is generally curved and extending from a first end 106 of the fold line 101 and a second portion 107 that is generally curved and extending from a second end 108 of the fold line 101. Both the first portion 105 and the second portion 107 of the cut 103 extend away from the fold line 101 and form a respective rounded corner 109, 111 of the cut that transitions to a third portion 113 of the cut. The third portion 113 is generally straight and extends in the lateral direction L2 between the two rounded corners 109, 111. In one embodiment, a slit or cut 112 is located adjacent the third portion 113 of the cut 103. As show in Figs. 1 and 10A, the article protection flap 13 comprises a second fold line 117 extending from the first end 106 of the first fold line 101 and a third fold line 119 extending from the second end 108 of the first fold line. In the first embodiment, the second and third fold lines 117, 119 are longitudinal fold lines that are generally parallel and extend in the longitudinal direction L1 of the blank 3. The fold lines 101, 117, 119 and cuts 103, 105 could be otherwise shaped, arranged, configured, and/or omitted such that the article protection flap 13 has any other suitable shape or configuration without departing from the disclosure.

[0078] In one embodiment, the first portion 105 of the cut 103, the rounded corner 109 of the cut, a portion of the third portion 113 of the cut, and the second fold line 117 at least partially define a first portion 121 of the article protection flap 13. The second portion 107 of the cut 103, the rounded corner 111 of the cut, a portion of the third portion 113 of the cut, and the third fold line 119 at least partially define a second portion 123 of the article protection flap. A central portion 125 of the article protection flap is at least partially defined by the first fold line 101, second fold line 117, third fold line 119, and a portion of the third portion 113 of the cut 103. The first portion 121 of the article protection flap 13 is foldably connected to the central portion 125 at the second fold line 117. The second portion 123 of the article protection flap 13 is foldably connected to the central portion 125 at the third fold line 119. The first portion 121 and the second portion 123 are foldable relative to each other and the central portion 125 by way of the fold lines 117, 119. Alternatively, the first portion 121 and second portion 123 could be foldably connected at a single fold line without departing from the disclosure.

[0079] Figs. 2-8 show one exemplary method of forming the carton 5 and the article protection features 11. As shown in Fig. 2, the blank 3 can be formed into a sleeve 131

having open ends 7, 9 by folding the bottom panel 15, side panels 17, 21, and top panel 25 along respective fold lines 19, 23, 27, 31. The adhesive panel 29 can be adhesively secured to the second side panel 21 by glue or other suitable adhesive. As shown in Fig. 3, containers C can be placed into an interior space 133 of the sleeve 131. One of the ends 7, 9 can be closed prior to loading the containers C or both of the ends 7, 9 can be closed after loading the containers into the interior space 133. The closing of the first end 7 is described below, but it is understood that the second end 9 can be closed in a similar manner, with the article protection features 11 in the second end being formed in a similar manner as the article protection features in the first end. Alternatively, the second end 9 could have different flap closing sequence or arrangement and the article protection features 11 could be otherwise shaped, arranged, configured, and/or omitted without departing from the disclosure.

[0080] As shown in Figs. 3 and 4, the first end 7 is closed by first inwardly folding the side end flaps 37, 43. As shown in Figs. 5-7, the bottom end flap 33 is upwardly folded and the top end flap 47 is downwardly folded to close the end 7 of the carton 5. The article protection features 11 in the first end of the carton 5 are formed during the closing of the end flaps 33, 37, 43, 47. As shown in Fig. 6, the indentations 81 on the exterior surface of the side end flaps 37, 43 are aligned with the indentations 83 on the interior surface of the bottom end flap 33 to form a respective article protection feature 11. As shown in Figs. 8 and 9, the outermost article protection features (when viewing the end 7 as shown in Fig. 9) are identified by reference number 11A and are formed by the indentation 81 on the side end flap 43 and the indentation 83 on the bottom end flap 33 that cooperate to form a pocket 135 in the overlapped end flaps. In one embodiment, the width of the pocket 135 as viewed in Fig. 9 is approximately equal to the combined amount of depression of each of the indentations 81, 83. The indentations 81 are on the exterior surface of the side end flaps 37, 43 and the indentations 83 are on the interior surface of the bottom end flap 33 so that the indentations 81, 83 cooperate to form the pocket 135. Alternatively, the article protection features 11 could comprise only a single indentation 81, 83, or one of the indentations 81, 83 could be larger or smaller than the other, or the indentations 81, 83 could be offset from one another, without departing from the disclosure. Moreover, the indentations 81, 83 could be arranged such that the protrusions are in direct contact with each other.

[0081] In one embodiment, the middle article protection features 11B (Figs. 8 and 9A) are formed by an indentation 81 on each of the side end flaps 37, 43 and an indentation on the bottom end flap 33. As shown in Fig. 9A, the indentation 81 near the edge of the inner side end flap 43 receives the indentation 81 near the edge of the outer side end flap 37, and the indentation 83 on the bottom end flap 33 cooperates with the indentation on the outer side end flap 37 to form the pocket 137. The article protection features 11A, 11B, and pockets 135, 137 could be otherwise shaped, arranged, positioned, and/or configured without departing from the disclosure.

[0082] Figs. 9B and 9C show alternative configurations of the article protection features 11A, 11B having pockets 135, 137 similar to the embodiments of Figs. 9 and 9A but filled with shock absorbing material 139. In one embodiment, the shock absorbing material 139 is a thermoplastic adhesive. The shock absorbing material 139 can comprise thermoplastic adhesive that can be hot-melt adhesive including a low temperature hot melt thermoplastic adhesive or a high temperature hot melt thermoplastic adhesive such as are commercially available. Such hot melt adhesive can include ethylene vinyl acetate (EVA) or any other suitable material. For example, the shock absorbing material 139 can comprise any suitable foam, gel, liquid, or solid, that can be located in the pocket 135, 137 and provide cushioning of the impact forces exerted on the carton 5. For example, the shock absorbing material could comprise any suitable heat activation material, UV activation material, laser activation material, Styrofoam, thermoplastic, hot melt adhesive, or any material that takes up space in the pocket 135, 137 to provide cushioning to the containers C. The article protection features 11 can comprise the same or different thermoplastic adhesive that is used to form and close the carton 5 without departing from the disclosure. In one embodiment, the adhesive used to form the shock absorbing material 139 can be further applied to one or more of the end flaps 33, 37, 43, 47 to secure the end flaps in the closed configuration of the end 7.

[0083] As shown in Fig. 9, the lower article protection feature 11, 11A, 11B is spaced apart from the bottom panel 15 by a first distance D1 and the upper article protection feature 11, 11A, 11B is spaced apart from the bottom panel by a second distance D2. In one embodiment, the second distance D2 is greater than the first distance D1. The distances D1 can be selected so that the lower article protection feature 11 contacts the container C near a bottom portion B of the container. The distance D2 can be selected so

that the upper article protection feature 11 contacts the container C near the shoulder S of the container. The positioning of the upper and lower article protection features 11 provides a respective container C with two contact points with the shock absorbing features at the end 7 of the carton 5 so that each respective container C is stabilized and cushioned against impacts occurring at the end of the carton. The article protection features could be otherwise arranged and positioned without departing from the disclosure.

[0084] Fig. 4A shows an alternative configuration of the end 7 wherein the side end flap 37 has two notches 141 instead of the indentations 81. The notches 141 allow the indentations 81 near the edge of the exterior surface of the side end flap 43 to cooperate with the middle indentations 83 on the bottom end flap 33 to form a pocket similar to the pocket 135 shown in Fig. 9, but with the pocket 135 being wider as a result of the intervening layer of material from the side end flap 37.

[0085] Figs. 5A and 5B show an alternative configuration of the end 7 wherein the bottom end flap 33 is modified from the bottom end flap shown in Fig. 4. In the embodiment of Figs. 5A and 5B, the indentations 83 on the interior surface near the peripheral edge of the bottom end flap 33 of Fig. 4 are replaced by a deformation 149 at the peripheral edge of the bottom end flap 33. The deformation 149 includes a series of indentations 151 on the interior surface of the bottom end flap 33 that are adjacent to a respective indentation on the exterior surface 153 of the bottom end flap. The indentations 151 on the interior surface of the bottom end flap 33 communicate with the upper indentations 81 on the side end flaps 37, 43 to form a respective pocket or series of pockets. Alternatively, the upper indentations 81 on the side end flaps 37, 43 could be replaced with a deformation similar to the deformation 149 of the bottom end flap, or any other configuration that is suitable for creating a pocket or series of pockets that form the article protection features.

[0086] Fig. 5C shows an alternative configuration of the end 7 wherein the side end flaps 37, 43 and bottom end flap 33 are modified from the flaps shown in Fig. 4. In the embodiment of Fig. 5C, the bottom end flap 33 has indentations 155 on the interior surface near the peripheral edge of the bottom end flap that are modified from the embodiment of Fig. 4. Further, the side end flaps 37, 43 each have upper indentations

157 that are modified from the embodiment of Figs. 4 and 5. Both groups of indentations 155, 157 are elongated from the embodiment of Figs. 4 and 5, and the indentations 155 on the bottom end flap are each sized to extend between two adjacent indentations 157 on the side end flaps 37, 43. The indentations 155 are in communication with multiple indentations 157 so that the pocket formed by the cooperating indentations forms an article protection feature 11 that is elongated and contacts two adjacent articles C. The elongated article protection feature can be filled with shock absorbing material in a similar manner as described above for the first embodiment. Alternatively, the lower indentations on the interior surface of the bottom end flap 33 and the lower indentations 81 on the side end flaps 37, 43 could be similar to the indentations 155, 157 without departing from the disclosure.

[0087] In the first embodiment, the loaded and closed carton 5 of Fig. 8 is further processed so that the article protection flaps 13 are activated. The article protection flaps 13 are foldably connected to the bottom panel 15 and moveable between a first position (Fig. 2) that is substantially parallel to the bottom panel and a second position (Fig. 8A) wherein the article protection flaps are folded relative to the bottom panel. In one embodiment, the article protection flaps 13 are raised or activated to the position of Fig. 8A, and the article protection flaps have features for preventing the folding of the article protection flaps from the second position back to the first position. Fig. 8A illustrates an outermost row of containers C removed and the end flaps 33, 37, 43, 47 at the end 7 open so that the article protection flaps 13 are visible. It is understood that the article protection flaps 13 will be activated to the second position (Fig. 8A) after the ends 7, 9 of the carton 5 have been closed. Alternatively, the article protection flaps 13 could be activated prior to closing one or both of the ends 7, 9 of the carton 5 without departing from the disclosure.

[0088] The article protection flaps 13 can be activated by various forming apparatus, some of which will be described below in further detail, or any other suitable method. The activation of a single article protection flap 13 will be described in detail herein, but it is understood that the other article protection flaps can be activated in a similar or different manner without departing from the disclosure. Figs. 10A and 10B are enlarged portions of the interior surface of the bottom panel 15, with Fig. 10A showing the interior surface of the bottom panel prior to activation of the article protection flap 13, and Fig.

10B showing the interior of the bottom panel after activation of the article protection flap. In one embodiment, a finger or other portion of an apparatus for forming the carton 5 presses against the central portion 125 (Fig. 10A) of the article protection flap 13 to initiate separation of the article protection flap from the bottom panel 13 along the cut 103. As shown in Figs. 8A, 10A, and 10C, the article protection flap 13 is pivoted upward relative to the bottom panel 15 at the fold line 101 in the direction of arrow A1 to create an opening 161 in the bottom panel. As the article protection flap 13 is activated, the first portion 121 and the second portion 123 are folded relative to each other. In one embodiment, the first portion 121 and the second portion 123 of the article protection flap are folded inwardly relative to each other and relative to the central portion 125. As such, the article protection flap 13 provides two layers of material (e.g., the inwardly folded first portion 121 and second portion 123) between adjacent containers C in the carton 5.

[0089] In one embodiment, the article protection flaps 13 are upwardly folded to the second (raised) position shown in Fig. 8A, or the article protection flaps can be upwardly folded to a second (raised) position shown in Fig. 10C. In one embodiment, the upwardly folding of the article protection flaps 13 causes the containers C in the carton 5 to move to accommodate the space required for the article protection flaps in the second position with the first portion 121 and second portion 123 folded relative to each other. The movement of the containers C when the article protection flaps 13 are upwardly folded and located between adjacent containers, tightens the packing of the containers in the carton 5 so that the movement of the containers is limited by the positioning of the article protection flaps 13 and the respective end flaps 33, 37, 43, 47 and 35, 39, 45, 49 at the closed ends 7, 9 of the carton. The article protection flaps 13 are pressed against two adjacent containers C to initiate movement of the containers and provide the tightening feature of the article protection flaps.

[0090] In one embodiment, the configuration of the first portion 121 and the second portion 123 prevents the article protection flap 13 from being downwardly folded from the second or raised position of Fig. 8 to the first or lowered position of Fig. 2. As shown in Fig. 10B, when the first portion 121 and the second portion 123 of the article protection flap 13 are inwardly folded relative to each other, the first and second portions extend beyond the edge 163 of the opening 161 created at the third portion 113 of the cut

103. In one embodiment, an edge 165 (Fig. 10C) of the first portion 121 of the article protection flap 13, formed by the rounded corner 109 of the cut 103 extends beyond the edge 163 of the opening 161. Also, an edge 167 (Fig. 10C) of the second portion 123 of the article protection flap 13 formed by the rounded corner 111 of the cut 103 extends beyond the edge 163 of the opening 161. The positioning of the distal portions of the first portion 121 and second portion 123, including the edges 165, 167 of the article protection flap 13, relative to the edge 163 of the opening 161 prevents the article protection flaps 13 from being downwardly folded to the first position wherein the article protection flaps are substantially parallel to the bottom panel 15. As such, once the article protection flaps 13 are raised to the second position and positioned between adjacent containers C, the article protection flaps stay in the upwardly folded position providing cushioning and protection between adjacent containers. The article protection flaps 13 could be otherwise shaped, arranged, and/or configured to have other features for preventing the article protection flaps from returning to the first or lowered position without departing from the disclosure.

[0091] Figs. 10D-10F show an article protection flap 13 having alternative features. In the embodiment of Figs. 10D-10F, the first portion 121 and the second portion 123 of the article protection flap 13 each have a respective deformation 171, 173 in the form of an indentation on the exterior surface of the article protection flap 13. The article protection flap 13 of the embodiment of Figs. 10D-10F is activated in a similar manner as described above for the previous embodiment, wherein the first portion 121 is folded relative to the second portion 123 of the article protection flap. As shown in Fig. 10F, the indentations 171, 173 of the respective first and second portions 121, 123 cooperate to form a space 175 between the first portion and the second portion of the article protection flaps 13. The space 175 can comprise shock absorbing material, such as the shock absorbing material 139 discussed above for the article protection features 11, or any other suitable material. The space 175 between the first and second portions 121, 123 of the article protection flap 13 of Fig. 10F provides enhanced article protection and reduction of breakage of the containers C. The deformations 171, 173 could be otherwise shaped, arranged, configured, positioned, and/or omitted without departing from the scope of the disclosure.

[0092] One embodiment of a system 181 for activating the article protection flaps 13 is illustrated in Figs. 11 and 12. In one embodiment, the cartons 5, having containers C loaded and the ends 7, 9 closed, are conveyed via an inlet conveyor 183 to a first or inlet end 185 of the system 181. However, the system 181 could also be used to activate the article protection flaps 13 of the cartons 5 prior to closing one or both of the ends 7, 9. The system 181 comprises a sled 187 that receives a carton 5 from the inlet conveyor 183 such that the bottom panel 15 of the carton is in contact with the top surface 189 of the sled. The sled 187 is operatively attached to a cam track array or section 191 that includes a series of spaced rails 193 (Fig. 12) with a series of cam tracks 195 mounted therebetween. The sled 187 comprises a series of actuating fingers 197 pivotally mounted to the sled and moveable through a respective slot 199 in the top surface 189 of the sled. The actuating fingers 197 have a lower portion that engages a respective cam track 195 such that the actuating finger 197 is raised or lowered in the slot 199 by the slope of the cam track. As the sled 187 with carton 5 mounted on the top surface 189 moves in the direction of arrow A2 (Fig. 11), the fingers 197 are raised and lowered in the slots 199 to activate the article protection flaps 13 in the bottom panel 15. After the article protection flaps 13 are activated by the system 181, the carton 5 exits an exiting end 201 of the system for further handling and packaging. The system 180 could be alternatively shaped, arranged, and/or configured without departing from the disclosure.

[0093] Fig. 13 illustrates an alternative embodiment of a system 207 for activating the article protection flaps 13 of the carton 5. The system 207 comprises a cassette 209 that can be mounted along the path of travel of the carton 5 in a packaging machine. In one embodiment, the cassette 209 comprises a series of actuating fingers 211 mounted to a chain 213. The fingers 211 move along a cam track 215 that receives a portion of the fingers 211 as the fingers are conveyed around the cassette. As the fingers 211 move along the cam track 215, the fingers can be positioned between non-engaging and engaging positions for selectively activating the article protection flaps 13 of the carton 5. The system 207 could be alternatively shaped, arranged, and/or configured without departing from the disclosure.

[0094] Fig. 14 shows features of an alternative embodiment of a system 221 for activating the article protection flaps 13 of the carton 5. As with the previous embodiments, the system 221 can be mounted along a path of travel of the cartons 5 in a

packaging machine. In the embodiment of Fig. 14, the system 221 includes a series of starred wheels or finned discs 223 that will engage and activate the article protection flaps 13 as the cartons move through or along system 221. The star wheels 223 each generally includes a series of actuating fingers 225 arranged in groups or sets spaced about the circumference or periphery 227 of each of the star wheels. In one embodiment, each of the star wheels 223 is positioned to activate a respective row of article protection flaps 13 in the bottom panel 15 of the carton. The actuating fingers 225 engage a respective article protection flap 13 and move the article protection flap from the first (lowered) position that is substantially parallel to the bottom panel 15 to the second (raised) position wherein the article protection flap 13 is folded relative to the bottom panel. The system 221 could be alternatively shaped, arranged, and/or configured without departing from the disclosure.

[0095] Fig. 15 is an alternative embodiment of a blank 303 that is similar to the blank 3 of the first embodiment. Accordingly, like or similar features will be indicated with like or similar reference numbers. The blank 303 is for forming a carton 5 having article protection features 11 in respective ends 7, 9 of the carton as discussed above for the first embodiment. As with the embodiment of Fig. 1, the blank 303 has end flaps 33, 37, 43, 47 and 35, 39, 45, 49 that have respective indentations or features 81, 83 that cooperate to form the article protection features 11. In contrast to the first embodiment, the blank 303 has a bottom panel 15 that does not have article protection flaps 13. The blank 303 could have other features and could be otherwise shaped, arranged, and/or configured without departing from the disclosure.

[0096] Fig. 16 is an alternative embodiment of a blank 403 that is similar to the blank 3 of the first embodiment. Accordingly, like or similar features will be indicated with like or similar reference numbers. The blank 403 is for forming a carton 5 having article protection flaps 13 foldably connected to the bottom panel 15 as discussed above for the first embodiment. In contrast to the first embodiment, the blank 403 has end flaps 33, 37, 43, 47 and 35, 39, 45, 49 that are free of respective indentations or features 81, 83 that cooperate to form the article protection features 11 of the carton 5 of the first embodiment. The blank 403 could have other features and could be otherwise shaped, arranged, and/or configured without departing from the disclosure.

[0097] Figs. 17-19 show an alternative embodiment of a blank 503 for forming a carton 505 that is similar to the blank 3 and carton 5 of the first embodiment. Accordingly, like or similar features will be indicated with like or similar reference numbers. The blank 503 has article protection flaps 513 that are similar to the article protection flaps 13 of the first embodiment. The blank 503 has fifteen article protection flaps 513 arranged in a 5x3 arrangement, but the blank could have more or less than fifteen article protection flaps and the article protection flaps could be otherwise arranged. In the embodiment of Figs. 17-19, the article protection flaps 513 are foldably connected to the bottom panel 15 at a lateral fold line 520 and are at least partially defined by a cut 522 or other line of weakening in the bottom panel. Two oblique fold lines 524, 526 extend from respective ends of the lateral fold line 520 to define a central portion 528 of the article protection flap 513. A first portion 530 of the article protection flap 513 is foldably connected to the central portion 528 at the oblique fold line 524 and a second portion 532 is foldably connected to the central portion 528 at the oblique fold line 526. In addition to the distal portions of the first portion 530 and second portion 532, the features that prevent the article protection flap 513 from being downwardly folded include a heel 534 formed at a distal portion of the article protection flap. In the illustrated embodiment, the heel 534 is a rounded protrusion that extends beyond the edge of the first and second portions 530, 532.

[0098] Fig. 18 illustrates a view of the bottom panel 15 of the carton 505 after the article protection flaps 15 have been activated and positioned in the second (raised) position between adjacent containers C. As shown in Figs. 18 and 19, the openings 561 is formed in the bottom panel 15 when the article protection flaps 513 are moved to the second position between adjacent containers. As shown in Fig. 19, the first and second portions 530, 532 are folded with respect to one another when a respective article protection flap 513 is positioned in the second position. In the raised position, the first portion 530, second portion 532, and heel 534 of each respective article protection flap 513 interfere with the edges of the bottom panel 15 at the opening 561 to prevent with the article protection flap from being moved to the first position that is substantially parallel to the bottom panel 15. The article protection flaps 513 could be otherwise shaped, arranged, configured, and/or positioned without departing from the disclosure.

[0099] Figs. 20 and 20A illustrate various features of a blank 603 according to an alternative embodiment of the disclosure and having similar features of the first embodiment. Accordingly, like or similar features will be indicated with like or similar reference numbers. The blank 603 has article protection flaps 613 that are similar in shape as the article protection flaps 513 of the previous embodiment. In the embodiment of Figs. 20 and 20A, the article protection flaps 613 are foldably connected to the bottom panel 15 at a lateral fold line 620 and are at least partially defined by a cut 622 or other line of weakening in the bottom panel. Two curved fold lines 624, 626 extend from respective ends of the lateral fold line 620 to define a central portion 628 of the article protection flap 613. A first portion 630 of the article protection flap 613 is foldably connected to the central portion 628 at the curved fold line 624 and a second portion 632 is foldably connected to the central portion 628 at the curved fold line 626. The article protection flap 613 comprises a heel 634 formed at a distal portion of the article protection flap. In the illustrated embodiment, the heel 634 is a rounded protrusion that extends beyond the edge of the first and second portions 630, 632 (e.g., is the farthest portion of the article protection flap 613 from the fold line 620). In the embodiment of Figs. 20 and 20A, the article protection flap 613 includes a lateral fold line 636 extending across the first portion 630 and the second portion 632 at the widest portion of the article protection flap and a longitudinal fold line 638 extending from the lateral fold line across the heel portion 634 to the cut 622. The fold lines 636, 638 facilitate the activation of the article protection flap 613 and the folding of the first portion 630 relative to the second portion 632. The article protection flaps 613 could be otherwise shaped, arranged, configured, and/or positioned without departing from the disclosure.

[00100] Figs. 21-23 illustrate various features of a blank 703 and carton 705 of an alternative embodiment having similar features as the first embodiment of the disclosure. Accordingly, like or similar features will be indicated with like or similar reference numbers. The blank 703 has a bottom panel 15 with article protection flaps 713 that are foldably connected to the bottom panel at a lateral fold line 720. In the embodiment of Figs. 21-23 two curved fold lines 724, 726 extend from respective ends of the lateral fold line 720 and define a central portion 728 of the article protection flap 713. The first portion 730 is foldably connected to the central portion 728 of the article protection flap 713 at the fold line 724 and the second portion 732 is foldably connected to the central portion at the fold line 726. The location of the containers C is shown in hidden lines in

Fig. 21, with the article protection flaps 713 in the first (lowered) position wherein the article protection flaps are substantially parallel to the bottom panel.

[00101] Fig. 22 shows the article protection flaps 713 being moved to the second position, and Fig. 23 shows the article protection flaps substantially in the second position. In both Figs. 22 and 23 one row of containers C has been removed to show the positioning of the article protection flaps 713. As with the previous embodiments, an opening 761 is formed in the bottom panel 15 that corresponds with the shape of the article protection flap 713 in the first position. As shown in Fig. 23, the first and second portions 730, 732 are curved or contoured to match the shape of the container C so that the container is held in secure engagement with the article protection flap 713. As with the previous embodiments, the article protection flaps 713 are prevented from being moved from the second (raised) position to the first (lowered) position by the interference of the folded first and second portions 730, 732 with the edge 763 of the bottom panel 15 at the opening 761. The folding of the first and second portions 730, 732 relative to each other and the central portion 730 causes the distal portions of the first and second portions to extend beyond the edge 763 forming the opening. The article protection flaps 713 could be otherwise shaped, arranged, configured, and/or positioned without departing from the disclosure.

[00102] Figs. 24-27 show an alternative embodiment of a blank 803 for forming a carton 805 that is similar to the blank 3 and carton 5 of the first embodiment. Accordingly, like or similar features will be indicated with like or similar reference numbers. The blank 803 has article protection flaps 13 that are the same as the article protection flaps of the first embodiment. The blank 803 has end flaps 33, 37, 43, 47 and 35, 39, 45, 49 that have respective indentations or features 81, 83 that cooperate to form the article protection features 811 that are similar to the article protection features 11, 11A, 11B of the first embodiment. The blank 803 could have other features without departing from the disclosure.

[00103] In the embodiment of Figs. 24-27, each of the top end flaps 47, 49 has a reinforcement flap 814 foldably connected to a base portion 816 of the top end flap at a longitudinal fold line 818. In one embodiment, the base portion 816 of each top end flap 47, 49 has a group of indentations 83a on the interior surface of the base portion 816 of

the end flap, and the reinforcement flap 814 has a group of indentations 83b on the interior surface of the end flap. As with the first embodiment, the side end flaps 37, 39, 43, 45 have indentations 81 on the exterior surface of the side end flaps and the bottom end flaps 33, 35 have indentations 83 on the interior surface of the bottom end flaps. In the embodiment of Figs. 24-27, each of the side end flaps 43, 45 have only a single indentation 81 on the lower row of indentations and an edge having notches 810 instead of a second indentation on the lower row. The blank 803 could have other arrangements of indentations 81, 83 or other features for forming the article protection features 811 without departing from the disclosure.

[00104] As shown in Figs. 25-27B, when the ends 7, 9 of the carton 805 are closed, the reinforcement flap 814 of each top end flap 47, 49 is folded at the fold line 818 to be in face-to-face contact with the interior surface of the base portion 816 of each end flap. As with the previous embodiments, only the closing of the first end 7 of the carton 805 is shown, but it is understood that the second end 9 could be closed in a similar manner as described for the first end. When the reinforcement flap 814 is folded, the indentations 83b on the reinforcement flap 814 are aligned and in contact with the indentations 83a on the base portion 816. The indentations 83a, 83b cooperate to form a pocket 836 (Fig. 27A) in the top end flap 47, 49 that is similar to pockets 135 discussed above for the first embodiment and shown in Fig. 9.

[00105] In the embodiment of Figs. 24-27B, the indentations 81 on the side end flaps 37, 39, 43, 45 and the indentations 83 on the bottom end flaps 33, 35 cooperate to form an upper pocket 135 that is similar to the upper pocket 135 described above for the first embodiment and shown in Fig. 9. The upper article protection feature 811A of the outermost article protection features (e.g., closest to the side panels 17, 21 when viewed from Fig. 27) comprises the pocket 836 formed by the reinforcement flap 814 and the base portion 816 of the top end flaps 47, 49 and the upper pocket 135 that is formed by the bottom end flap 33, 35 and the side end flaps 37, 39, 43, 45. The lower article protection features 811B of the outermost article protection features comprises the lower pocket 135 that is formed by the indentation 83 on the bottom end flaps 33, 35 and the indentation 81 on the side end flaps 37, 39, 43, 45. Either or both of the pockets 836, 135 that form the article protection features 811A, 811B could comprise shock absorbing material as described above for the first embodiment. The article protection features

811A, 811B could be formed by other features of the blank 803 without departing from the disclosure.

[00106] As shown in Figs. 27 and 27B, the upper article protection feature 811C of the middle article protection features (e.g., between the two outer article protection features 811A) comprises the pocket 836 in the top end flaps 47, 49 and the upper pocket 137 that is formed by the indentations 81 of bottom end flaps 33, 35 and the overlapped portions of the side end flaps 37, 39, 43, 45. The lower article protection features 811D of the middle article protection features comprises the lower pocket 137 that is formed by the indentations 81 of the overlapped portions of the side end flaps 43. As with the previous embodiments, any or all of the pockets 135, 137, 836 could be filled with shock-absorbing material 139 without departing from the disclosure. The pockets 135, 137 can be similar to the corresponding pockets shown in Fig. 9 for the first embodiment, or the pockets could be otherwise shaped, arranged, configured, and/or omitted. Any of the article protection features 811, 811A, 811B, 811C, 811D could be otherwise shaped, arranged, and/or configured without departing from the disclosure.

[00107] In one embodiment, the reinforcement flaps 814 are folded under the base portion 816 to provide an extra layer of material to reinforce and enhance the cushioning and protection of the container C by the article protection features 811A in the closed ends 7, 9 of the carton 805. Alternatively, the reinforcement flap 814 could be folded over and be in contact with the exterior surface of the base portion 816 so that the reinforcement flap is in face-to-face contact with the exterior surface of the base portion. Alternatively, the reinforcement flaps 814 and base portions 816 could be otherwise shaped, arranged, and/or configured without departing from the disclosure.

[00108] Fig. 28 illustrates various features of a blank 903 for forming a carton of an alternative embodiment having similar features as the first embodiment of the disclosure. Accordingly, like or similar features will be indicated with like or similar reference numbers. The blank 903 has a bottom panel 15 with primary article protection flaps 913 that are arranged in a single row of three article protection flaps. Secondary article protection flaps 914 are foldably connected to the bottom panel 15 and are spaced apart from a respective primary article protection flap 913. In the illustrated embodiment, four secondary article protection flaps 914 are included, but more or less than four secondary

article protection flaps could be used, or the secondary article protection flaps could be otherwise shaped, arranged, and/or configured without departing from the disclosure. The secondary article protection flaps 914 provide additional cushioning of the containers C and tightening of the carton 5 formed from the blank 903.

[00109] In one embodiment, the secondary article protection flaps 914 are smaller than the primary article protection flaps 913, but it is understood that the article protection flaps could be otherwise shaped, arranged, and/or configured. The primary and second article protection flaps 913, 914 can be moved to a second (raised) position in a similar manner as described above for the previous embodiments. In the illustrated embodiment, the blank 903 comprises a second top panel 926 that is placed in face-to-face contact with the first top panel 25 to reinforce the top panel of the carton formed from the blank 903. However, it is understood that the primary article protection flaps 913 and secondary article protection flaps 914 could be included on any other style of blanks (e.g., blanks similar to the blank 3 of Fig. 1 having only a single top panel 25) for use in forming any other style of carton without departing from the disclosure.

[00110] Figs. 29-30 illustrate various features of a blank 1003 for forming a carton 1005 of an alternative embodiment having similar features as the first embodiment of the disclosure. Accordingly, like or similar features will be indicated with like or similar reference numbers. The blank 1003 is for forming the carton 1005 that is a carrier having an interior space 1008 that has a generally open top with a divider 1010 that at least partially divides the interior space into a front portion 1012 and a back portion 1014. In one embodiment, the divider 1010 comprises a handle 1016 and the divider does not extend down to the bottom panel 1015. The divider 1010 could be otherwise shaped, arranged, and/or configured without departing from the disclosure.

[00111] In the illustrated embodiment, the blank 1003 has a front panel 1020, back panel 1022, and respective side panels 1024, 1026, 1028, 1030 for forming the sides of the carton 1005. The blank 1003 has divider panels 1032, 1034, 1036, 1038 that combine to form the divider 1010 of the carton 1005. In one embodiment the bottom panel 1015 is foldably connected to the back panel 1022 but the bottom panel 1015 could be otherwise arranged without departing from the disclosure. The bottom panel 1015 includes article protection flaps 1013 that are similar to the article protection flaps 13 of the first

embodiment. The article protection flaps 1013 are foldably connected to the bottom panel 1015 and arranged in a single row of three flaps. In the illustrated embodiment, the article protection flaps 1013 are positioned in the second (raised) position in a similar manner as the previous embodiments. The article protection flaps 1013 are positioned on the bottom panel 1015 so that the flaps are placed between adjacent containers C, with one of the adjacent containers being located in the front portion 1012 of the interior space 1008 and the other of the adjacent containers being located in the back portion 1014 of the interior space. The article protection flaps 1013 could be otherwise shaped, arranged, and/or configured without departing from the disclosure.

[00112] Figs. 31A-31C illustrate various features of a blank 1103 for forming a carton 1105 of an alternative embodiment having similar features as the previous embodiments of the disclosure. Accordingly, like or similar features will be indicated with like or similar reference numbers. The blank 1103 is a single panel for supporting the plurality of containers C. The blank 1103 comprises article protection flaps 1113 similar to the article protection flaps 13 of the earlier embodiments. The carton 1105 is formed by placing the plurality of containers C on the blank 1103 and then activating the article protection flaps 1113 by moving the article protection flaps from the first position that is substantially parallel to the blank 1103 to the second position wherein the article protection flaps are folded relative to the panel of the blank. In one embodiment, the carton 1105 can be further assembled by applying an overwrap of shrink-wrap (e.g., shrinkable polymer film) or other packaging material M so that the containers are securely attached to the blank 1103. In the embodiment of Figs. 31A-31C the blank 1103 is a bottom panel, but the blank could be otherwise shaped, arranged, or configured without departing from the disclosure.

[00113] In an alternative embodiment, blank 1103 and articles C with activated article protection flaps 113 can be positioned relative to a construct to at least partially enclose the blank and the at least two articles. In one embodiment the construct can be a sleeve similar to the sleeve 131 of Fig. 2. Further the construct can have at least one open end, such as the ends 7, 9 that can be closed by respective end flaps. The blank 1103 and articles C can be positioned in an interior of the sleeve prior to closing both the ends 7, 9, or one of the ends can be closed prior to positioning the blank and articles. Alternatively,

the construct could be a lid that fits over the tops of the articles C, and the lid could have one or more side panels extending down from a top panel.

[00114] Figs. 32A-32C illustrate various features of a blank 1203 for forming a carton 1205 of an alternative embodiment having similar features as the previous embodiments of the disclosure. Accordingly, like or similar features will be indicated with like or similar reference numbers. The blank 1203 comprises a bottom panel 1214 and four side panels 1218, 1220, 1222, 1224 for forming a tray 1226 (Fig. 32B) having an interior space for holding the container C. The blank 1203 comprises article protection flaps 1213 similar to the article protection flaps 13 of the earlier embodiments. The carton 1205 is formed by placing the plurality of containers C on the bottom panel 1214 of the blank 1203 and upwardly folding the side panels 1218, 1220, 1222, 1224 to form the tray 1226. The article protection flaps 1213 are activated by moving the article protection flaps from the first position that is substantially parallel to the bottom panel 1214 to the second position wherein the article protection flaps are folded relative to the bottom panel of the blank 1203. In one embodiment, the carton 1205 can be further assembled by applying an overwrap of shrink-wrap (e.g., shrinkable polymer film) or other packaging material M so that the containers are securely attached to the tray 1226. In the embodiment of Figs. 32A-32C the blank 1203 is configured for forming the tray 1226, but the blank could be otherwise shaped, arranged, or configured without departing from the disclosure.

[00115] Figs. 33A-33C illustrate various features of a blank 1303 for forming a carton 1305 of an alternative embodiment having similar features as the previous embodiments of the disclosure. Accordingly, like or similar features will be indicated with like or similar reference numbers. The blank 1303 is generally similar to the blank 3 of the first embodiment in that the blank of Figs. 33A-33C comprises a bottom panel 1315 and a first side panel 1317, a second side panel 1321, and a top panel 1325. The blank 1303 comprises article protection flaps 1313 similar to the article protection flaps 13 of the earlier embodiments. The carton 1305 is formed by placing the plurality of containers C on the bottom panel 1214 of the blank 1203 and upwardly folding the side panels 1317, 1321 around the containers on the bottom panel to partially form the carton as shown in Fig. 33B. Next, the top panel 1325 is downwardly folded to close the interior of the carton 1305 and the ends 1307, 1309 are closed by closing respective end flaps 1333,

1337, 1343, 1347 and 1335, 1339, 1345, and 1349. The article protection flaps 1313 are activated by moving the article protection flaps from the first position that is substantially parallel to the bottom panel 1315 to the second position wherein the article protection flaps are folded relative to the bottom panel 1315 of the blank 1303. The blank 1303 could be otherwise shaped, arranged, or configured without departing from the disclosure.

[00116] The cartons of any of the illustrated or non-illustrated embodiments of the disclosure could have other features (e.g., dispenser features, handle features, reinforcement features, etc.) without departing from the disclosure. Also, the cartons could be otherwise shaped, arranged, or configured and the cartons could be configured to hold articles other than beverage containers C without departing from the disclosure.

[00117] In general, the blanks of any of the illustrated or non-illustrated embodiments may be constructed from paperboard having a caliper so that it is heavier and more rigid than ordinary paper. The blank can also be constructed of other materials, such as cardboard, or any other material having properties suitable for enabling the carton to function at least generally as described above. The blank can be coated with, for example, a clay coating. The clay coating may then be printed over with product, advertising, and other information or images. The blanks may then be coated with a varnish to protect information printed on the blanks. The blanks may also be coated with, for example, a moisture barrier layer, on either or both sides of the blanks. The blanks can also be laminated to or coated with one or more sheet-like materials at selected panels or panel sections.

[00118] As an example, a tear line can include: a slit that extends partially into the material along the desired line of weakness, and/or a series of spaced apart slits that extend partially into and/or completely through the material along the desired line of weakness, or various combinations of these features. As a more specific example, one type of tear line is in the form of a series of spaced apart slits that extend completely through the material, with adjacent slits being spaced apart slightly so that a nick (e.g., a small somewhat bridging-like piece of the material) is defined between the adjacent slits for typically temporarily connecting the material across the tear line. The nicks are broken during tearing along the tear line. The nicks typically are a relatively small

percentage of the tear line, and alternatively the nicks can be omitted from or torn in a tear line such that the tear line is a continuous cut line. That is, it is within the scope of the present disclosure for each of the tear lines to be replaced with a continuous slit, or the like. For example, a cut line can be a continuous slit or could be wider than a slit without departing from the present disclosure.

[00119] In accordance with the exemplary embodiments, a fold line can be any substantially linear, although not necessarily straight, form of weakening that facilitates folding there along. More specifically, but not for the purpose of narrowing the scope of the present disclosure, fold lines include: a score line, such as lines formed with a blunt scoring knife, or the like, which creates a crushed or depressed portion in the material along the desired line of weakness; a cut that extends partially into a material along the desired line of weakness, and/or a series of cuts that extend partially into and/or completely through the material along the desired line of weakness; and various combinations of these features. In situations where cutting is used to create a fold line, typically the cutting will not be overly extensive in a manner that might cause a reasonable user to incorrectly consider the fold line to be a tear line.

[00120] The above embodiments may be described as having one or more panels adhered together by glue during erection of the carton embodiments. The term “glue” is intended to encompass all manner of adhesives commonly used to secure carton panels in place.

[00121] The foregoing description of the disclosure illustrates and describes various embodiments. As various changes could be made in the above construction without departing from the scope of the disclosure, it is intended that all matter contained in the above description or shown in the accompanying drawings shall be interpreted as illustrative and not in a limiting sense. Furthermore, the scope of the present disclosure covers various modifications, combinations, alterations, etc., of the above-described embodiments. Additionally, the disclosure shows and describes only selected embodiments, but various other combinations, modifications, and environments are within the scope of the disclosure as expressed herein, commensurate with the above teachings, and/or within the skill or knowledge of the relevant art. Furthermore, certain features and characteristics of each embodiment may be selectively interchanged and applied to other illustrated and non-illustrated embodiments of the disclosure.

What is claimed is:

1. A carton for containing at least one article, the carton comprising:

at least one panel at least partially forming an interior of the carton;

at least one article protection flap for protecting the at least one article,

the at least one article protection flap is foldably connected to the at least one panel and moveable between a first position that is substantially parallel to the at least one panel and a second position wherein the article protection flap is folded relative to the at least one panel, the article protection flap has features for preventing folding of the article protection flap from the second position to the first position.
2. The carton of claim 1, wherein the article protection flap comprises a first portion of the article protection flap and a second portion of the article protection flap that are foldable relative to each other.
3. The carton of claim 2 wherein the first portion and the second portion are folded relative to each other when the article protection flap is in the second position.
4. The carton of claim 3 wherein the first portion and the second portion are inwardly folded relative to each other.
5. The carton of claim 2 wherein the at least one panel comprises an opening having an edge at least partially formed by a line of weakening defining at least a portion of the article protection flap, the features for preventing folding of the article protection flap comprise a free edge of at least one of the first portion and the second portion that extend beyond the edge of the opening.
6. The carton of claim 5 wherein the line of weakening is a cut line.
7. The carton of claim 5 wherein the line of weakening is a tear line.
8. The carton of claim 5 wherein the features for preventing folding of the article protection flap comprise a distal portion of the first portion and a distal portion of the second portion.

9. The carton of claim 8 wherein the features for preventing folding of the article protection flap comprises a heel portion at the distal end of the flap.
10. The carton of claim 5 wherein the at least one panel comprises a slit adjacent the opening.
11. The carton of claim 1 wherein the article protection flap is foldably connected to the at least one panel at a first fold line.
12. The carton of claim 11 wherein the article protection flap comprises a second fold line extending from the first fold line and a third fold line extending from the first fold line.
13. The carton of claim 12 wherein the article protection flap comprises a central portion at least partially defined by the first fold line, the second fold line, and the third fold line.
14. The carton of claim 13 wherein the first fold line is a lateral fold line, the second fold line extends from the first fold line and the third fold line extends from the first fold line.
15. The carton of claim 14 wherein the second fold line and the third fold line are longitudinal fold lines.
16. The carton of claim 14 wherein the second fold line and the third fold line are curved.
17. The carton of claim 13 wherein the first portion is foldably connected to the central portion at the second fold line and the second portion is foldably connected to the central portion at the third fold line.
18. The carton of claim 1 wherein the at least one article protection flap comprises a plurality of article protection flaps arranged in a 3x3 arrangement.
19. The carton of claim 18 wherein the at least one article comprises a plurality of articles, each of the article protection flaps is positioned between two respective adjacent articles of the plurality of articles.

20. The carton of claim 1 wherein the interior has a first end and a second end, the at least one article being arranged in at least one row that extends from the first end to the second end.

21. The carton of claim 20 wherein the at least one article comprises a plurality of articles, and the at least one article protection flap is positioned between two adjacent articles of the plurality of articles.

22. The carton of claim 21 wherein the at least one row comprises at least three rows and the at least one article protection flap comprises at least three article protection flaps, each article protection flap being positioned between adjacent articles in a respective one of the at least three rows.

23. The carton of claim 22 wherein the at least three article protection flaps are primary article protection flaps, the carton further comprising secondary article protection flaps foldably connected to the at least one panel.

24. The carton of claim 1 wherein the plurality of panels comprises a bottom panel, a first side panel foldably connected to the bottom panel, and a second side panel foldably connected to the bottom panel.

25. The carton of claim 24 wherein the plurality of panels further comprises a top panel foldably connected to the first side panel and the second side panel.

26. The carton of claim 1 wherein the carton is a carrier wherein the interior of the carton has a generally open top for receiving at least one of the articles, the plurality of panels further comprises a divider panel for at least partially dividing the interior into a first portion and a second portion.

27. The carton of claim 25 further comprising:

at least two end flaps respectively foldably connected to respective panels of the plurality of panels, the end flaps being at least partially overlapped to close an end of the carton; and

at least one article protection feature for protecting at least one of the plurality of articles, the at least one article protection feature is positioned between the at least two end flaps.

28. The carton of claim 4 wherein at least one of the first portion and the second portion comprises a deformation for enhancing article protection.

29. The carton of claim 28 wherein the deformation is a first deformation on the first portion and a second deformation on the second portion, the first deformation and the second deformation cooperating to form a pocket between the first portion and the second portion.

30. A blank for forming a carton for containing at least one article, the blank comprising:

at least one panel for at least partially forming an interior of the carton formed from the blank;

at least one article protection flap for protecting the at least one article,

the at least one article protection flap is foldably connected to the at least one panel and moveable between a first position that is substantially parallel to the at least one panel and a second position wherein the article protection flap is folded relative to the at least one panel, the article protection flap has features for preventing folding of the article protection flap from the second position to the first position in the carton formed from the blank.

31. The blank of claim 30, wherein the article protection flap comprises a first portion of the article protection flap and a second portion of the article protection flap that are foldable relative to each other.

32. The blank of claim 31 wherein the first portion and the second portion are for being folded relative to each other when the article protection flap is in the second position.

33. The blank of claim 31 wherein the at least one panel comprises a line of weakening at least partially defining the article retention flap, the line of weakening forming an opening having an edge in the carton formed from the blank, the features for preventing folding of the article protection flap comprise a free edge of at least one of the first portion and the second portion that extend beyond the edge of the opening in the carton formed from the blank.

34. The blank of claim 33 wherein the line of weakening is a cut line.
35. The blank of claim 33 wherein the line of weakening is a tear line.
36. The blank of claim 33 wherein the line of weakening is shaped to form a distal portion of the first portion and a distal portion of the second portion, the features for preventing folding of the article protection flap comprise the distal portion of the first portion and the second portion.
37. The blank of claim 36 wherein the line of weakening is shaped to form a heel portion at the distal end of the flap, the features for preventing folding of the article protection flap comprises the heel portion.
38. The blank of claim 33 wherein the at least one panel comprises a slit adjacent the line of weakening.
39. The blank of claim 30 wherein the article protection flap is foldably connected to the at least one panel at a first fold line.
40. The blank of claim 39 wherein the article protection flap comprises a second fold line extending from the first fold line and a third fold line extending from the first fold line.
41. The blank of claim 40 wherein the article protection flap comprises a central portion at least partially defined by the first fold line, the second fold line, and the third fold line.
42. The blank of claim 41 wherein the first fold line is a lateral fold line, the second fold line extends from the first fold line and the third fold line extends from the first fold line.
43. The blank of claim 42 wherein the second fold line and the third fold line are longitudinal fold lines.
44. The blank of claim 42 wherein the second fold line and the third fold line are curved.
45. The blank of claim 41 wherein the first portion is foldably connected to the central portion at the second fold line and the second portion is foldably connected to the central portion at the third fold line.

46. The blank of claim 30 wherein the at least one article protection flap comprises a plurality of article protection flaps arranged in a 3x3 arrangement.

47. The blank of claim 30 wherein the at least one article protection flap comprise a primary article protection flap foldably connected to the at least one panel and a secondary article protection flap foldably connected to the at least one panel.

48. The blank of claim 30 wherein the plurality of panels comprises a bottom panel, a first side panel foldably connected to the bottom panel, and a second side panel foldably connected to the bottom panel.

49. The blank of claim 48 wherein the plurality of panels further comprises a top panel foldably connected to the first side panel and the second side panel.

50. The blank of claim 30 wherein the carton formed from the blank is a carrier, wherein the interior of the carton has a generally open top for receiving at least one of the articles, the plurality of panels further comprises a divider panel for at least partially dividing the interior into a first portion and a second portion.

51. The blank of claim 48 further comprising:

at least two end flaps respectively foldably connected to respective panels of the plurality of panels, the end flaps being at least partially overlapped to close an end of the carton formed from the blank; and

at least one article protection feature for protecting at least one of the plurality of articles, the at least one article protection feature is positioned between the at least two end flaps in the carton formed from the blank.

52. The blank of claim 31 wherein at least one of the first portion and the second portion comprises a deformation for enhancing article protection.

53. The blank of claim 52 wherein the deformation is a first deformation on the first portion and a second deformation on the second portion, the first deformation and the second deformation cooperating to form a pocket between the first portion and the second portion.

54. A method of forming a carton, the method comprising:

obtaining a blank comprising at least one panel and at least one article protection flap foldably connected to the at least one panel;

positioning the at least one panel to at least partially form an interior space of the carton;

loading at least one article in the interior space;

folding the at least one article protection flap relative to the at least one panel after the loading the at least one article, the folding comprises moving the article protection flap from a first position that is substantially parallel to the at least one panel to a second position wherein the article protection flap is folded relative to the at least one panel.

55. The method of claim 54 wherein the loading at least one article comprises loading a plurality of articles.

56. The method of claim 55 wherein the at least one article protection flap comprises a plurality of article protection flaps, and the folding comprises positioning each of the article protection flaps between two respective adjacent articles of the plurality of articles.

57. The method of claim 55 wherein the at least one article protection flap comprises features to facilitate the folding of the flap between adjacent articles.

58. The method of claim 54 wherein the positioning the panels comprises forming a sleeve having a first end and a second end, the blank has a first plurality of end flaps at one end of the blank and a second plurality of end flaps at a second end of the blank, the method comprises closing the first end by at least partially overlapping the first plurality of end flaps and closing the second end by at least partially overlapping the second plurality of end flaps.

59. The method of claim 58 wherein at least one of the closing the first end and the closing the second end is before the folding the at least one article protection flap.

60. The method of claim 58 wherein at least one of the closing the first end and the closing the second end is during the folding the at least one article protection flap.

61. The method of claim 58 wherein at least one of the closing the first end and the closing the second end is after the folding the at least one article protection flap.

62. The method of claim 58 wherein the loading the at least one article comprises arranging a plurality of the articles in at least one row that extends from the first end to the second end, the at least one article protection flap being positioned between two respective adjacent articles in the at least one row.

63. The method of claim 62 wherein the at least one row comprises at least three rows and the at least one article protection flap comprises at least three article protection flaps, the folding comprises positioning each article protection flap between adjacent articles in a respective one of the at least three rows.

64. The method of claim 63 wherein the at least three article protection flaps are primary article protection flaps, the carton further comprising secondary article protection flaps foldably connected to the at least one panel, the method further comprises folding the secondary article protection flaps after the loading of the plurality of articles.

65. The method of carton of claim 54, wherein the article protection flap has features for preventing folding of the article protection flap from the second position to the first position.

66. The method of claim 65 wherein the article protection flap comprises a first portion and a second portion, and the folding of the article protection flap comprises folding the first portion and the second portion relative to each other.

67. The method of claim 66 wherein the first portion and the second portion are folded about a fold line during the folding so that the first portion and the second portion are inwardly folded relative to each other.

68. The method of claim 67 wherein the at least one panel comprises an opening formed by the folding of the article protection flap from the first position to the second position, the opening having an edge at least partially formed by a line of weakening defining at least a portion of the article protection flap, the features for preventing folding of the article protection flap comprise a free edge of at least one of the first portion and the second portion that are positioned to extend beyond the edge of the opening during the folding the first portion and the second portion relative to each other.

69. The method of claim 68 wherein the features for preventing folding of the article protection flap comprises a distal portion of the first portion and a distal portion of the second portion.

70. The method claim 69 wherein the features for preventing folding of the article protection flap comprises a heel of the flap at the distal end of the flap.

71. The method of claim 66 wherein the article protection flap is foldably connected to the at least one panel at a first fold line, the article protection flap comprises a second fold line extending from the first fold line and a third fold line extending from the first fold line, the article protection flap comprises a central portion at least partially defined by the first fold line, the second fold line, and the third fold line, the first fold line is a longitudinal fold line, the second fold line extends from the first fold line and the third fold line extends from the first fold line, the folding the first portion and second portion relative to each other comprises folding the first portion at the second fold line and folding the second portion at the third fold line.

72. The method of claim 54 wherein the plurality of panels comprises a bottom panel, a first side panel foldably connected to the bottom panel, and a second side panel foldably connected to the bottom panel, the positioning the plurality of panels comprises positioning the first side panel and the second side panel relative to the bottom panel.

73. The method of claim 72 wherein the plurality of panels further comprises a top panel foldably connected to the first side panel and the second side panel, the positioning the plurality of panels comprises positioning the top panel relative to the first side panel and the second side panel.

74. The method of claim 54 wherein the carton is a carrier and wherein the interior of the carton has a generally open top for receiving at least one of the articles, the plurality of panels comprises a divider panel and the positioning the panels comprises positioning the divider panel to at least partially divide the interior into a first portion and a second portion.

75. The method of claim 54 wherein the folding the at least one article protection flap comprises engaging the at least one article protection flap with a finger of a mechanism for forming the carton.

76. The method of claim 54 wherein the folding the at least one article protection flap comprises contacting the at least one article and moving the article.

77. A carton for containing at least one article, the carton comprising:

a plurality of panels that extends at least partially around an interior of the carton;

at least two end flaps respectively foldably connected to respective panels of the plurality of panels, the end flaps being at least partially overlapped to close an end of the carton;

at least one article protection feature for protecting the at least one article, the at least one article protection feature is positioned between the at least two end flaps.

78. The carton of claim 77 wherein the at least two end flaps comprises a first end flap and a second end flap, the article protection feature comprises at least one feature on one of the first end flap and the second end flap.

79. The carton of claim 78 wherein the at least one feature comprises a first feature on the first end flap and a second feature on the second end flap.

80. The carton of claim 79 wherein the first feature and the second feature are generally aligned at the closed end.

81. The carton of claim 79 wherein the first feature and the second feature are generally adjacent.

82. The carton of claim 79 wherein the first feature and the second feature are in communication with each other.

83. The carton of claim 80 wherein the first feature comprises a first deformation and the second feature comprises a second deformation.

84. The carton of claim 83 wherein the first deformation comprises an indentation on an exterior surface of the first end flap and the second deformation comprises an indentation on an interior surface of the second end flap.

85. The carton of claim 84 wherein the first feature and the second feature combine to form a pocket in the overlapped first and second end flaps, the pocket being for providing cushioning of the at least one article.

86. The carton of claim 85 wherein the pocket comprises a shock absorbing material that provides cushioning of the at least one of the articles.

87. The carton of claim 86 wherein the material is a thermoplastic adhesive.

88. The carton of claim 86 wherein the material is an adhesive, and the adhesive is further applied between the first end flap and the second end flap to secure the end flaps in a closed position.

89. The carton of claim 85 further comprising a third feature on the first end flap and a fourth feature on the second end flap, the third feature and the fourth feature are generally aligned at the closed end, the third feature comprises an indentation on the exterior surface of the first end flap and the fourth feature comprises an indentation on the interior surface of the second end flap, the pocket is a first pocket and the third feature and the fourth feature combine to form a second pocket in the overlapped first and second end flaps for providing cushioning of the at least one of the articles in the carton.

90. The carton of claim 89 wherein the second pocket comprises a shock absorbing material that provides cushioning of the at least one of the articles in the carton.

91. The carton of claim 89 wherein the plurality of panels comprises a bottom panel and the first pocket is spaced apart from the bottom panel by a first distance, the second pocket is spaced apart from the bottom panel by a second distance, the first distance is less than the second distance.

92. The carton of claim 89 wherein the plurality of panels comprises a bottom panel, a first side panel foldably connected to the bottom panel, and a second side panel foldably connected to the bottom panel, and the first end flap is a side end flap foldably connected to one of the first and second side panels, and the second end flap is a bottom end flap foldably connected to the bottom panel.

93. The carton of claim 77 further comprising at least one article protection flap for protecting the at least one article, the article protection flap is foldably connected to at

least one panel of the plurality of panels and is moveable between a first position that is substantially parallel to the at least one panel and a second position wherein the article protection flap is folded relative to the at least one panel, the article protection flap has features for preventing folding of the article protection flap from the second position to the first position.

94. The carton of claim 93 wherein the article protection flap has a first portion and a second portion that are folded relative to each other when the article protection flap is in the second position.

95. The carton of claim 85 wherein the plurality of panels comprises a bottom panel, a first side panel foldably connected to the bottom panel, and a second side panel foldably connected to the bottom panel, and the first end flap is a side end flap foldably connected to one of the first and second side panels, the second end flap is a bottom end flap foldably connected to the bottom panel, and further comprising a third end flap foldably connected to one of the first and second side panels.

96. The carton of claim 95 further comprising a third deformation on the third end flap, the third deformation being generally aligned with the first deformation to form the pocket.

97. The carton of claim 95 wherein the third end flap comprises a notch that is generally aligned with the first feature and the second feature.

98. The carton of claim 85 wherein the pocket is a first pocket and one of the at least two end flaps comprises a base portion and a reinforcement flap foldably connected to the base portion, the one of the at least two end flaps comprises a third feature on the base portion and a fourth feature on the reinforcement flap, the third feature and the fourth feature are generally aligned at the closed end with the third feature and the fourth feature forming a second pocket adjacent the first pocket.

99. The carton of claim 98 wherein the third feature is an indentation on the interior surface of the base portion and the fourth feature is an indentation on the interior surface of the reinforcement flap.

100. The carton of claim 99 wherein the reinforcement flap is in generally face-to-face contact with the base portion.

101. A blank for forming a carton for containing at least one article, the blank comprising:

a plurality of panels for extending at least partially around an interior of the carton formed from the blank;

at least two end flaps respectively foldably connected to respective panels of the plurality of panels, the end flaps being at least partially overlapped to close an end of the carton formed from the blank;

at least one article protection feature for protecting the at least one article, the at least one article protection feature is for being positioned between the at least two end flaps.

102. The blank of claim 101 wherein the at least two end flaps comprises a first end flap and a second end flap, the article protection feature comprises at least one feature on one of the first end flap and the second end flap.

103. The blank of claim 102 wherein the at least one feature comprises a first feature on the first end flap and a second feature on the second end flap.

104. The blank of claim 103 wherein the first feature and the second feature are positioned on the respective end flaps to be generally aligned at the closed end of the carton formed from the blank.

105. The blank of claim 103 wherein the first feature and the second feature are generally adjacent in the carton formed from the blank.

106. The blank of claim 103 wherein the first feature and the second feature are in communication with each other in the carton formed from the blank.

107. The blank of claim 104 wherein the first feature comprises a first deformation and the second feature comprises a second deformation.

108. The blank of claim 107 wherein the first deformation comprises an indentation on an exterior surface of the first end flap and the second deformation comprises an indentation on an interior surface of the second end flap.

109. The blank of claim 108 wherein the first feature and the second feature are for forming a pocket in the overlapped first and second end flaps in the carton formed from the blank, the pocket being for providing cushioning of the at least one article.

110. The blank of claim 109 wherein the pocket comprises a shock absorbing material that provides cushioning of the at least one of the articles.

111. The blank of claim 110 wherein the material is a thermoplastic adhesive.

112. The blank of claim 110 wherein the material is an adhesive, and the adhesive is further applied between the first end flap and the second end flap to secure the end flaps in a closed position in the carton formed from the blank.

113. The blank of claim 109 further comprising a third feature on the first end flap and a fourth feature on the second end flap, the third feature and the fourth feature are for being generally aligned at the closed end of the carton formed from the blank, the third feature comprises an indentation on the exterior surface of the first end flap and the fourth feature comprises an indentation on the interior surface of the second end flap, the pocket is a first pocket and the third feature and the fourth feature are for forming a second pocket in the overlapped first and second end flaps for providing cushioning of the at least one of the articles in the carton formed from the blank.

114. The blank of claim 113 wherein the second pocket comprises a shock absorbing material that provides cushioning of the at least one of the articles in the carton formed from the blank.

115. The blank of claim 113 wherein the plurality of panels comprises a bottom panel, a first side panel foldably connected to the bottom panel, and a second side panel foldably connected to the bottom panel, and the first end flap is a side end flap foldably connected to one of the first and second side panels, and the second end flap is a bottom end flap foldably connected to the bottom panel.

116. The blank of claim 101 further comprising at least one article protection flap for protecting the at least one article, the article protection flap is foldably connected to at least one panel of the plurality of panels and is moveable between a first position that is substantially parallel to the at least one panel and a second position wherein the article protection flap is folded relative to the at least one panel, the article protection flap has features for preventing folding of the article protection flap from the second position to the first position.

117. The blank of claim 116 wherein the article protection flap has a first portion and a second portion that are folded relative to each other when the article protection flap is in the second position.

118. The blank of claim 109 wherein the plurality of panels comprises a bottom panel, a first side panel foldably connected to the bottom panel, and a second side panel foldably connected to the bottom panel, and the first end flap is a side end flap foldably connected to one of the first and second side panels, the second end flap is a bottom end flap foldably connected to the bottom panel, and further comprising a third end flap foldably connected to one of the first and second side panels.

119. The blank of claim 118 further comprising a third deformation on the third end flap, the third deformation is for being generally aligned with the first deformation to form the pocket in the carton formed from the blank.

120. The blank of claim 118 wherein the third end flap comprises a notch that is for being generally aligned with the first feature and the second feature in the carton formed from the blank.

121. The blank of claim 109 wherein the pocket is a first pocket and one of the at least two end flaps comprises a base portion and a reinforcement flap foldably connected to the base portion, the one of the at least two end flaps comprises a third feature on the base portion and a fourth feature on the reinforcement flap, the third feature and the fourth feature are for being generally aligned at the closed end of the carton formed from the blank with the third feature and the fourth feature forming a second pocket adjacent the first pocket in the carton formed from the blank.

122. The blank of claim 121 wherein the third feature is an indentation on the interior surface of the base portion and the fourth feature is an indentation on the interior surface of the reinforcement flap.

123. The blank of claim 122 wherein the reinforcement flap is for being in generally face-to-face contact with the base portion in the carton formed from the blank.

124. A method of forming a carton for containing at least one article, the method comprises:

obtaining a blank comprising a plurality of panels and at least two end flaps respectively foldably connected to a respective panel of the plurality of panels;

positioning the plurality of panels to form an interior space of the carton;

loading at least one article in the interior space;

at least partially overlapping the at least two end flaps to close an end of the carton; and

forming an article protection feature that is positioned between the at least two end flaps.

125. The method of claim 124 wherein the at least two end flaps comprises a first end flap and a second end flap, the article protection feature comprises at least one feature on one of the first end flap and the second end flap.

126. The method of claim 125 wherein the at least one feature comprises a first feature on the first end flap and a second feature on the second end flap.

127. The method of claim 126 wherein the forming the article protection feature comprises generally aligning the first feature and the second feature at the closed end.

128. The method of claim 127 wherein the forming the article protection feature comprises positioning at least one of the first feature and the second feature so that the first feature and second feature are generally adjacent.

129. The method of claim 127 wherein the forming the article protection feature comprises positioning at least one of the first feature and the second feature so that the first feature and the second feature are in communication.

130. The method of claim 126 wherein the first feature comprises a first deformation and the second feature comprises a second deformation.

131. The method of claim 130 wherein the first deformation comprises an indentation on an exterior surface of the first end flap and the second deformation comprises an indentation on an interior surface of the second end flap.

132. The method of claim 131 wherein the forming the article protection feature comprises combining the first feature and the second feature to form a pocket in the overlapped first and second end flaps, the pocket being for providing cushioning of the at least one article in the carton.

133. The method of claim 132 wherein the forming the article protection feature comprises placing a shock absorbing material in the pocket to provide cushioning of the at least one article.

134. The method of claim 133 wherein the material is a thermoplastic adhesive applied to one of the indentation on the first end flap and the indentation on the second end flap.

135. The method of claim 133 wherein the material is an adhesive, and the method further comprises applying the adhesive between the first end flap and the second end flap to secure the end flaps in a closed position.

136. The method of claim 133 wherein the article protection feature comprises a third feature on the first end flap and a fourth feature on the second end flap, the forming the article protection feature comprising generally aligning the third feature and the fourth feature at the closed end, the third feature comprises an indentation on the exterior surface of the first end flap and the fourth feature comprises an indentation on the interior surface of the second end flap, the pocket is a first pocket and the third feature and the fourth feature combine to form a second pocket in the overlapped first and second end flaps for providing cushioning of the at least one of the articles in the carton.

137. The method of claim 136 further comprising placing a shock absorbing material in the second pocket that provides cushioning of the at least one of the articles in the carton.

138. The method of claim 137 wherein the plurality of panels comprises a bottom panel, and the first pocket is spaced apart from the bottom panel by a first distance, the second

space is spaced apart from the bottom panel by a second distance, the first distance is less than the second distance.

139. A method of forming a carton, the method comprising:

obtaining a blank comprising a panel and at least one article protection flap foldably connected to the panel;

positioning at least two articles to be in contact with the panel;

folding the at least one article protection flap relative to the panel after the positioning the at least two articles, the folding comprises moving the article protection flap from a first position that is substantially parallel to the panel to a second position wherein the article protection flap is folded relative to the panel.

140. The method of claim 139 wherein the panel comprises a bottom panel and the method further comprises applying packaging material to the articles to secure the articles to the bottom panel.

141. The method of claim 139 wherein the panel is a bottom panel and the blank further comprises at least one side panel.

142. The method of claim 141 further comprising forming the blank into a tray by folding the at least one side panel relative to the bottom panel.

143. The method of claim 142 wherein the at least one side panel comprises four side panels.

144. The method of claim 143 further comprising applying packaging material to the articles to secure the articles to the tray.

145. The method of claim 142 wherein the at least one side panel comprises a first side panel and a second side pane, and the blank further comprises a top panel.

146. The method of claim 145 further comprising folding the blank by positioning the first side panel and the second side panel relative to the bottom panel to at least partially enclose the at least two articles.

147. The method of claim 146 wherein the blank further comprises a top panel and the folding the blank comprises positioning the top panel relative to the first side panel and the second side panel to form an a sleeve forming an interior of the carton.

148. The method of claim 147 wherein the blank comprises end flaps at at least one end, the method further comprises positioning the end flaps to at least partially close an end of the sleeve.

149. The method of claim 139 wherein the at least one article protection flap comprises a plurality of article protection flaps and the at least two articles comprises a plurality of articles, and the folding comprises positioning each of the article protection flaps between two respective articles of the plurality of articles.

150. The method of claim 139 wherein the article protection flap has features for preventing folding of the article protection flap from the second position to the first position.

151. The method of claim 150 wherein the article protection flap comprises a first portion and a second portion, and the folding of the article protection flap comprises folding the first portion and the second portion relative to each other.

152. The method of claim 139 further comprising positioning the blank and the at least two articles relative to a construct to at least partially enclose the blank and the at least two articles.

153. The method of claim 152 wherein the construct is a sleeve having at least one open end.

154. The method of claim 153 further comprising closing at least one end of the sleeve after the positioning the blank and the at least two articles in an interior space of the sleeve.

155. A carton for containing at least one article, the carton comprising:

at least one panel at least partially forming an interior of the carton;

at least two end flaps at least partially overlapped to at least partially close the interior of the carton;

at least one article protection feature for protecting the at least one article, the at least one article protection feature is positioned between the at least two end flaps; and

at least one article protection flap for protecting the at least one article, the at least one article protection flap is foldably connected to the at least one panel and moveable between a first position that is substantially parallel to the at least one panel and a second position wherein the article protection flap is folded relative to the at least one panel.

156. The carton of claim 155 wherein the article protection flap has features for preventing folding of the article protection flap from the second position to the first position.

157. The carton of claim 156 wherein the article protection flap comprises a first portion of the article protection flap and a second portion of the article protection flap, the first portion and the second portion are foldably connected and are folded relative to each other when the article protection flap is in the second position.

158. The carton of claim 157 wherein the at least one panel comprises an opening having an edge at least partially formed by a line of weakening defining at least a portion of the article protection flap, the features for preventing folding of the article protection flap comprise a free edge of at least one of the first portion and the second portion that extend beyond the edge of the opening.

159. The carton of claim 155 wherein the at least two end flaps comprises a first end flap and a second end flap, the article protection feature comprises a first feature on the first end flap and a second feature on the second end flap.

160. The carton of claim 159 wherein the first feature comprises a first deformation and the second feature comprises a second deformation.

161. The carton of claim 160 wherein the first deformation comprises an indentation on an exterior surface of the first end flap and the second deformation comprises an indentation on an interior surface of the second end flap.

162. The carton of claim 161 wherein the first feature and the second feature combine to form a pocket in the overlapped first end flap and second end flap, the pocket providing cushioning to the at least one article.

163. The carton of claim 162 wherein the pocket comprises a shock absorbing material that provides cushioning to the at least one article.

164. A method of forming a carton, the method comprising:

obtaining a blank comprising at least one panel, at least one article protection flap foldably connected to the at least one panel, and at least two end flaps;

positioning the at least one panel to at least partially form an interior space of the carton;

loading at least one article in the interior space;

at least partially overlapping the at least two end flaps to close and end of the carton;

forming an article protection feature that is positioned between the at least two end flaps;
and

folding the at least one article protection flap relative to the at least one panel after the loading the at least one article, the folding comprises moving the article protection flap from a first position that is substantially parallel to the at least one panel to a second position wherein the article protection flap is folded relative to the at least one panel.

165. The method of claim 164 wherein the article protection flap has features for preventing folding of the article protection flap from the second position to the first position, the article protection flap comprises a first portion and a second portion that are foldably connected to each other, the folding of the article protection flap comprises folding the first portion and the second portion relative to each other.

166. The method of claim 165 wherein the at least one panel comprises an opening formed by the folding of the article protection flap from the first position to the second position, the opening having an edge at least partially formed by a line of weakening defining at least a portion of the article protection flap, the features for preventing folding of the article protection flap comprise a free edge of at least one of the first portion and the second portion that extend beyond the edge of the opening during the folding the first portion and the second portion.

167. The method of claim 164 wherein the at least two end flaps comprises a first end flap and a second end flap, the article protection feature comprises a first feature on the

first end flap and a second feature on the second end flap, and forming the article protection feature comprises generally aligning the first feature and the second feature at the closed end.

168. The method of claim 167 wherein the first feature comprises a first deformation and the second feature comprises a second deformation.

169. The method of claim 168 wherein the first deformation comprises an indentation on an exterior surface of the first end flap and the second deformation comprises an indentation on an interior surface of the second end flap.

170. The method of claim 169 wherein the forming the article protection feature comprises combining the first feature and the second feature to form a pocket in the overlapped first end flap and second end flap, the pocket providing cushioning to the at least one article.

171. The method of claim 170 wherein the forming the article protection feature comprises placing a shock absorbing material in the pocket to provides cushioning to the at least one article.

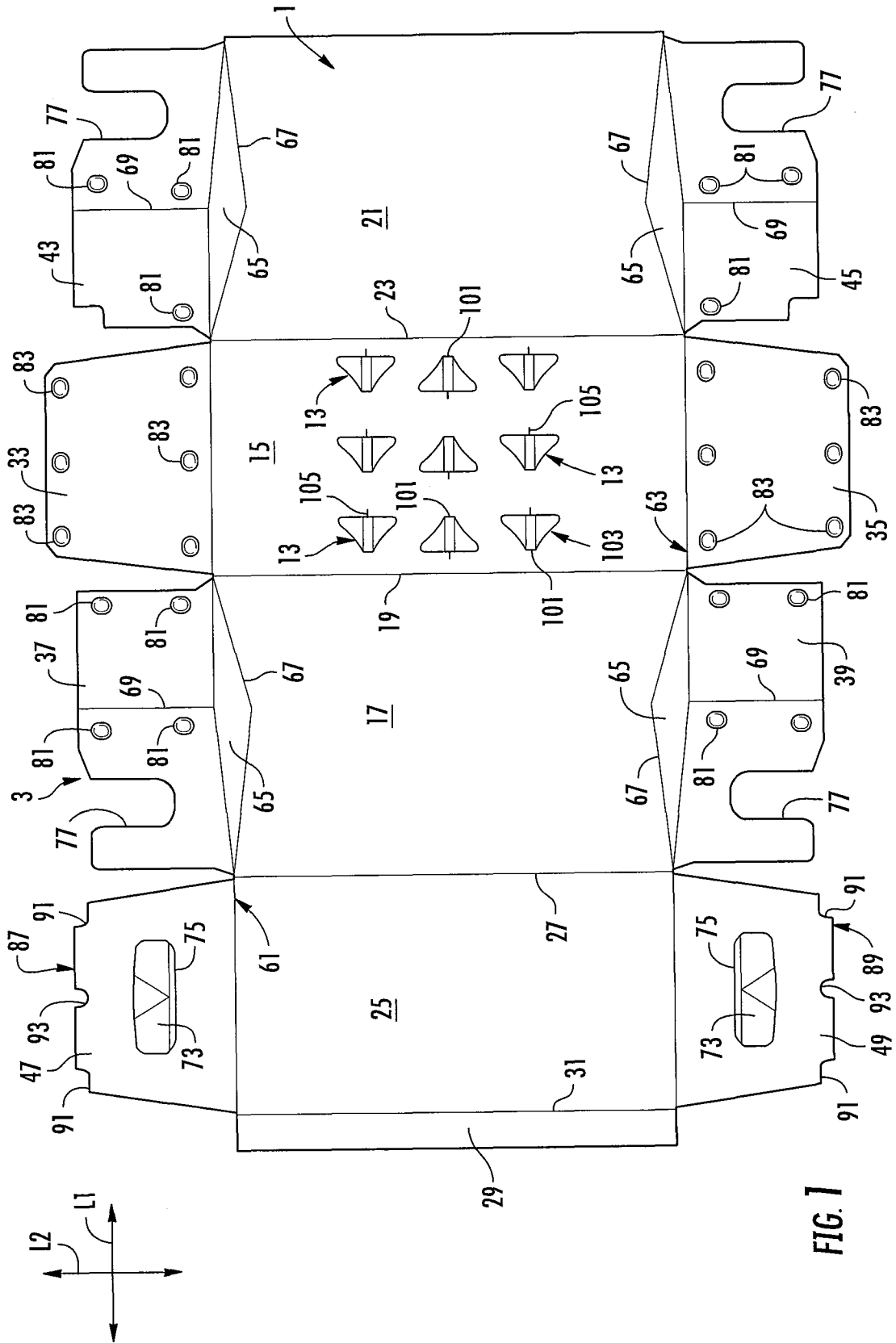

FIG. 1

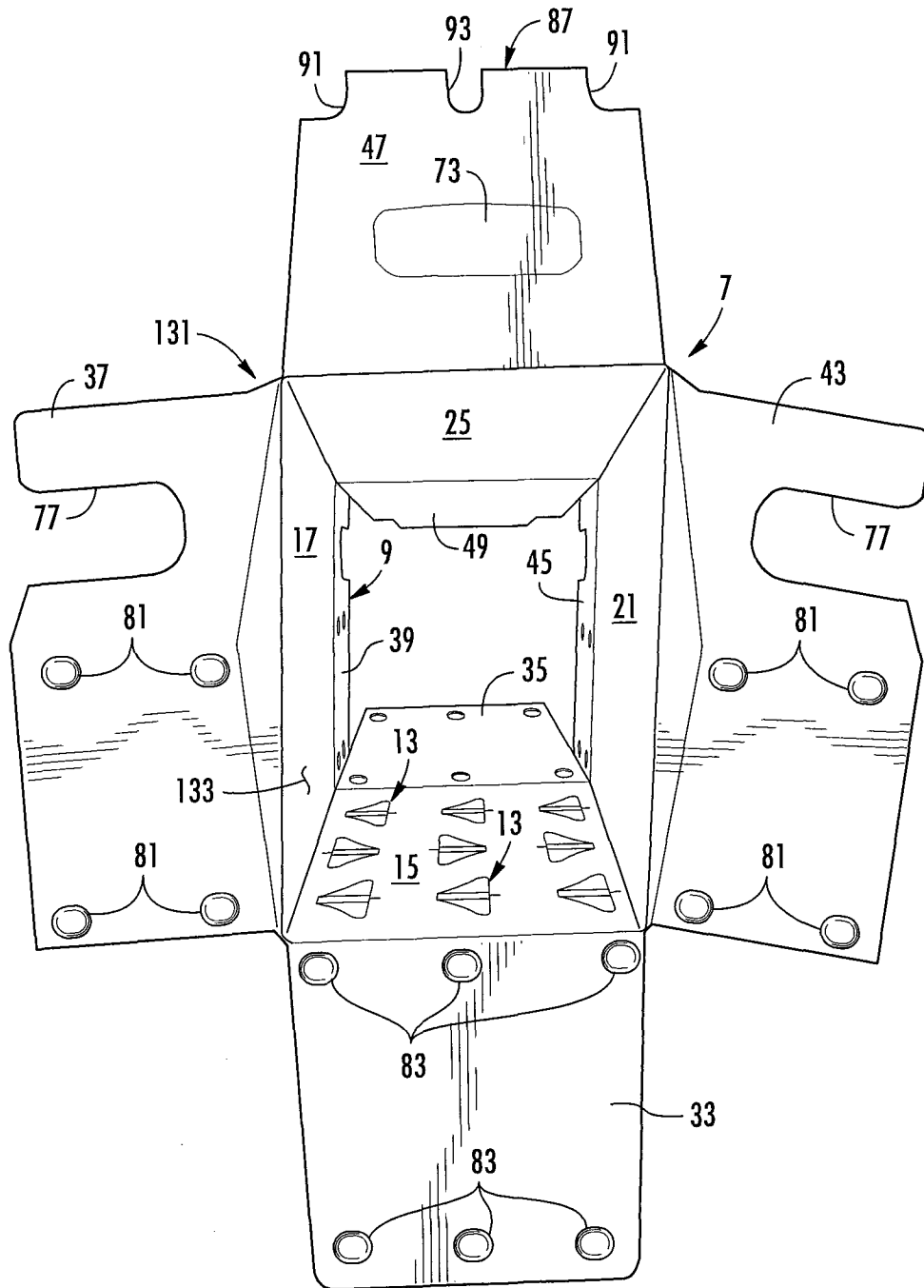

FIG. 2

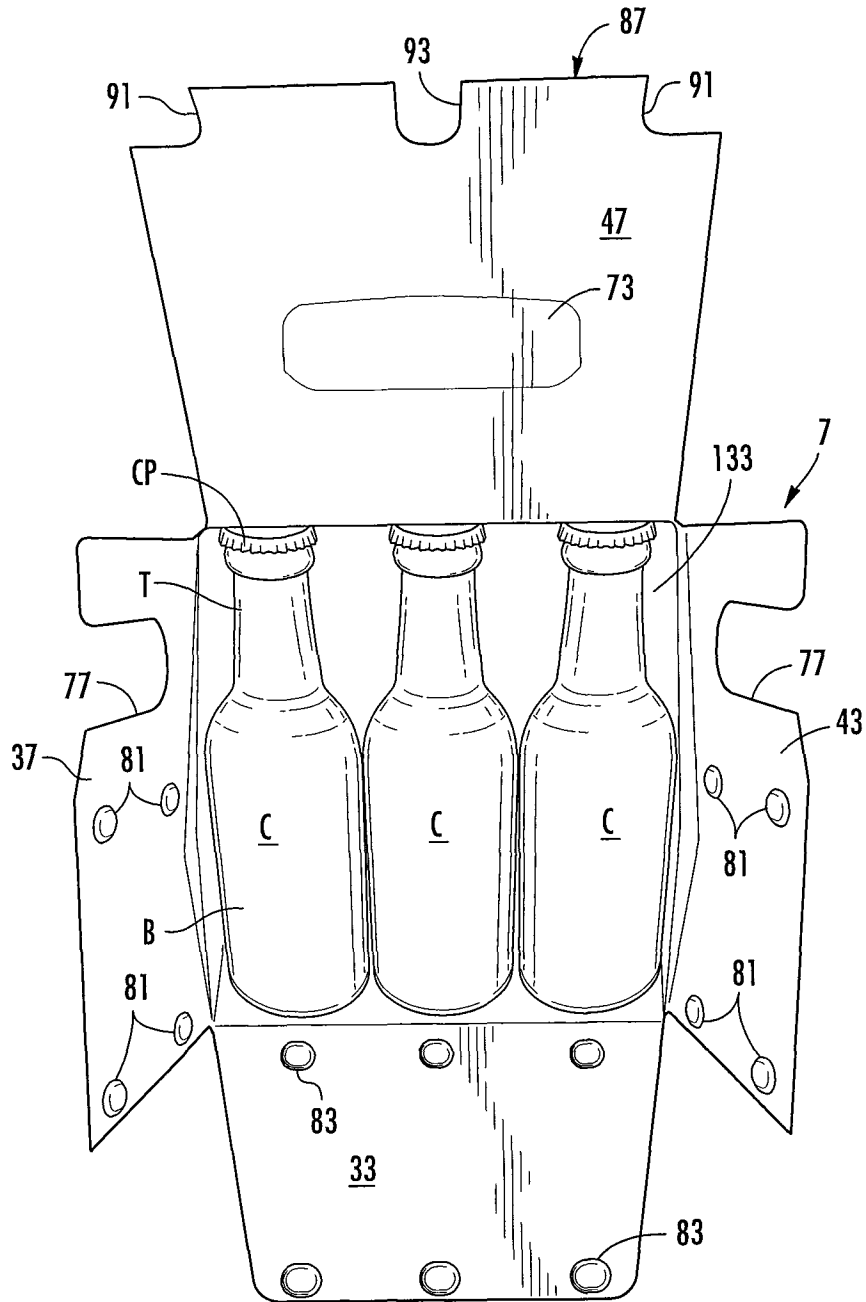

FIG. 3

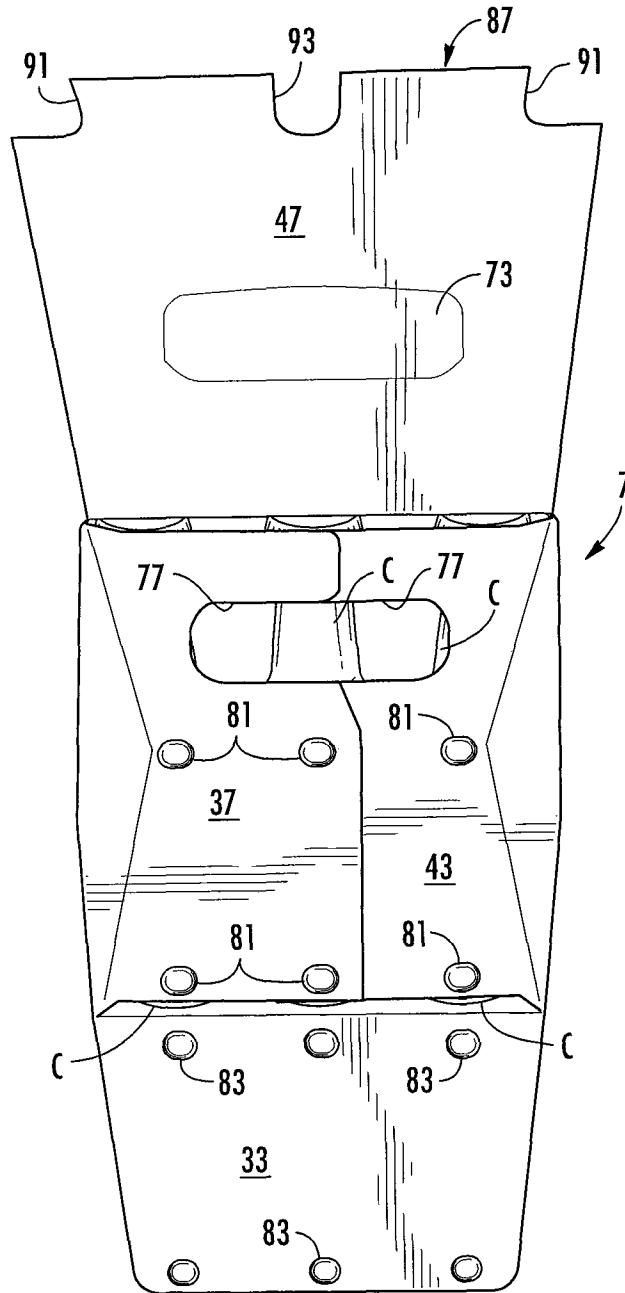

FIG. 4

5/36

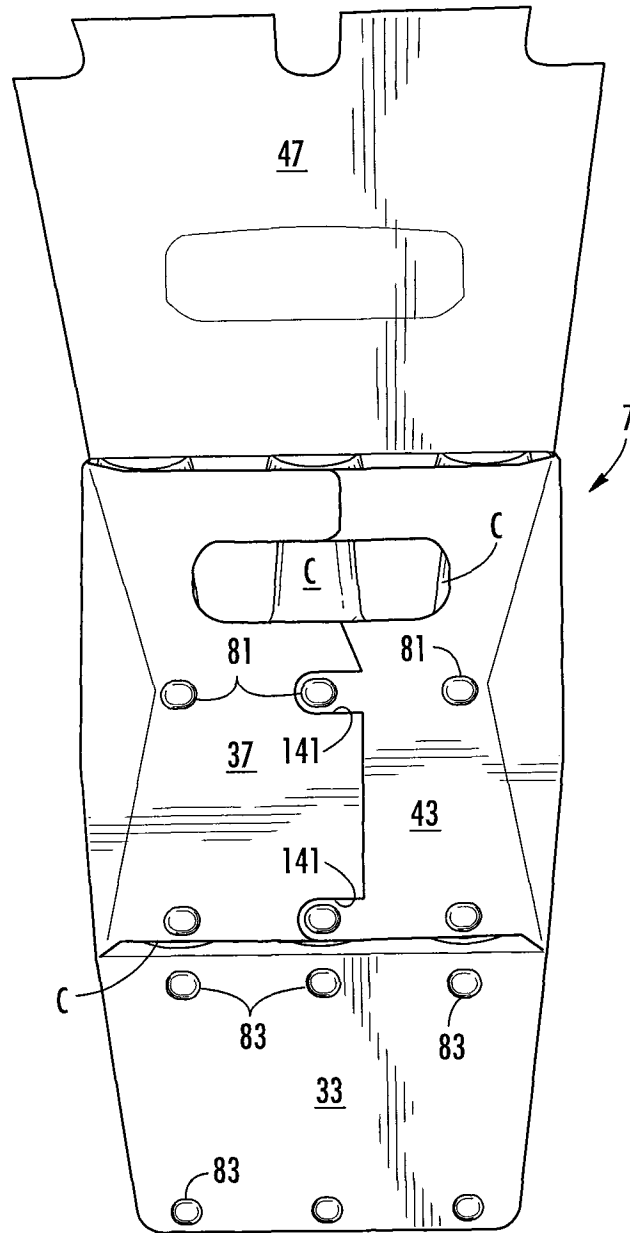

FIG. 4A

6/36

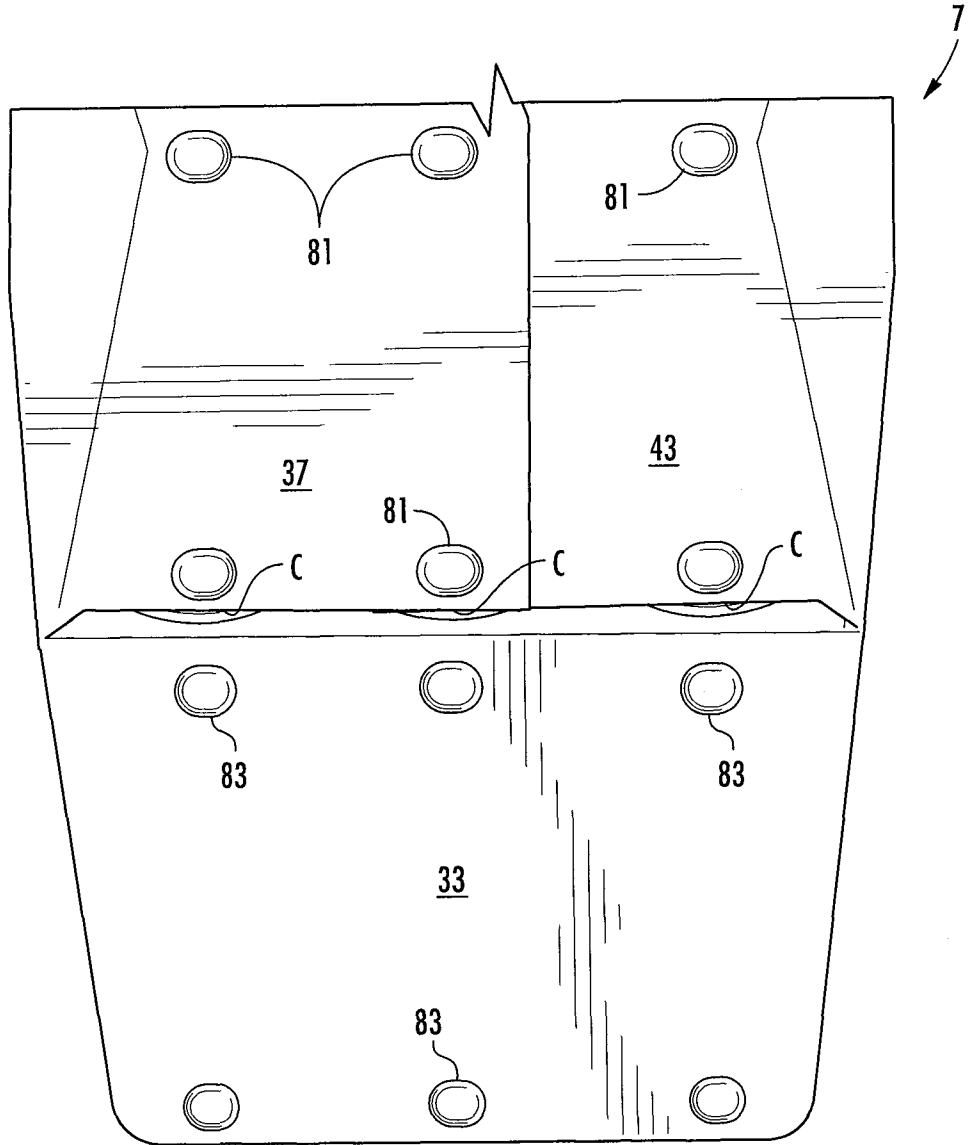

FIG. 5

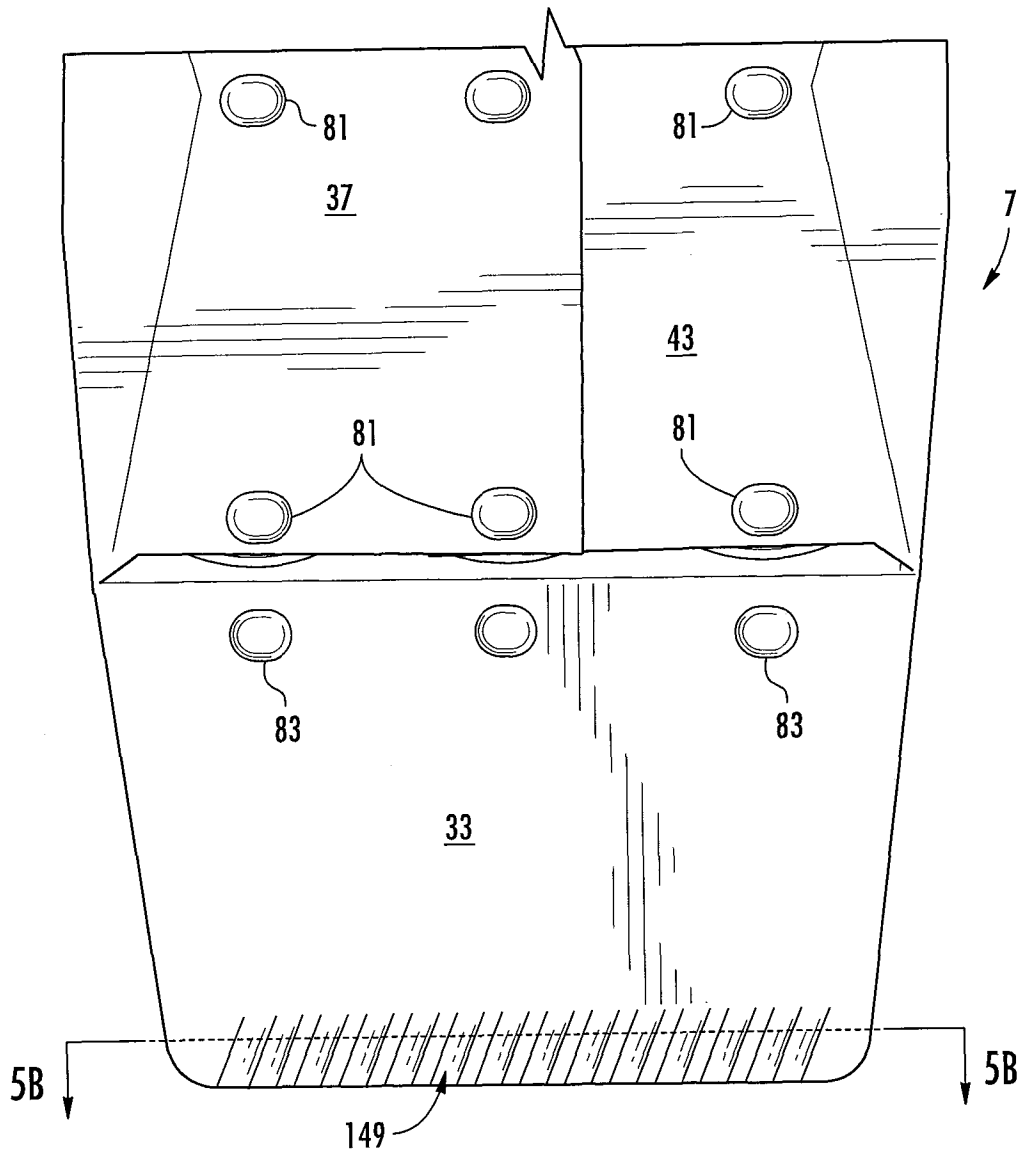

FIG. 5A

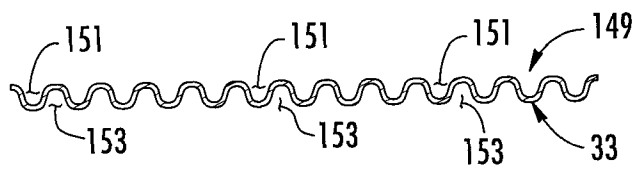

FIG. 5B

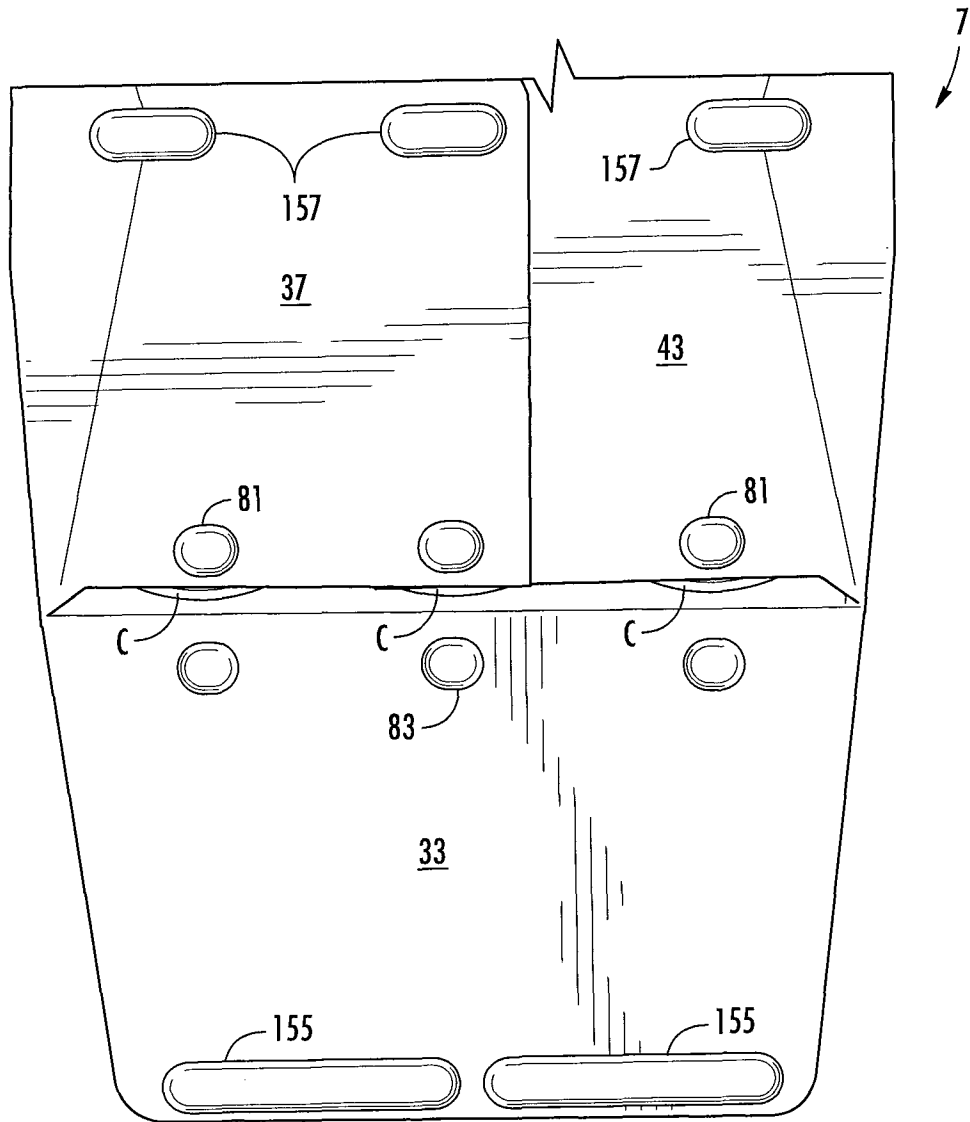

FIG. 5C

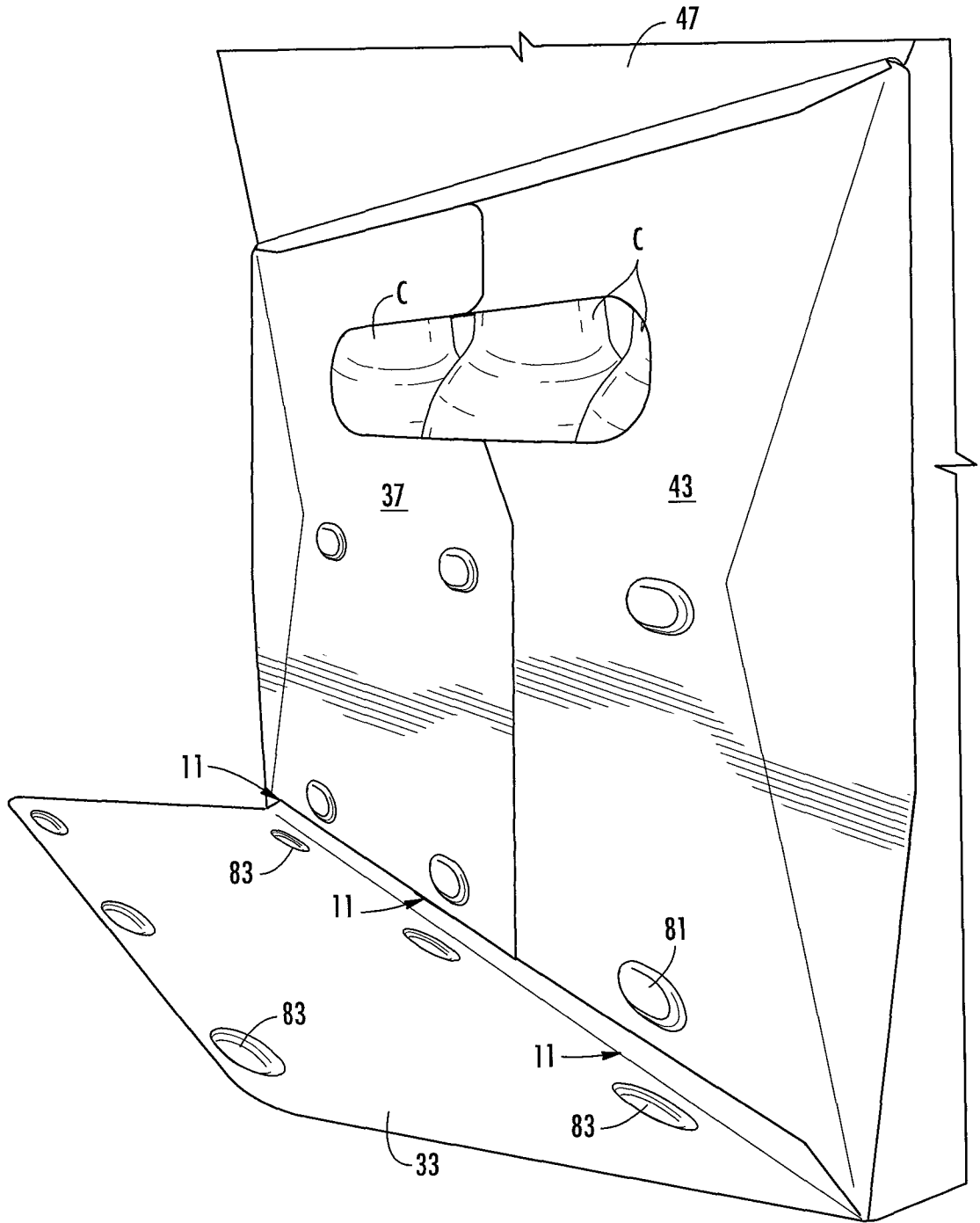

FIG. 6

10/36

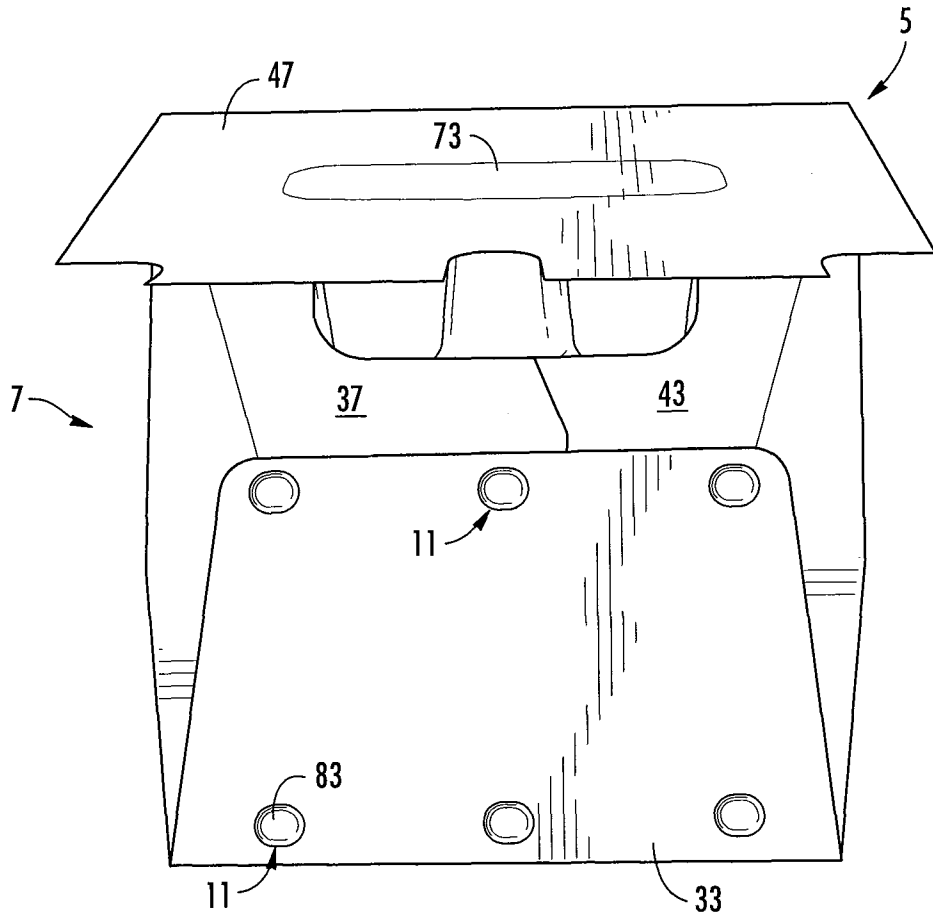

FIG. 7

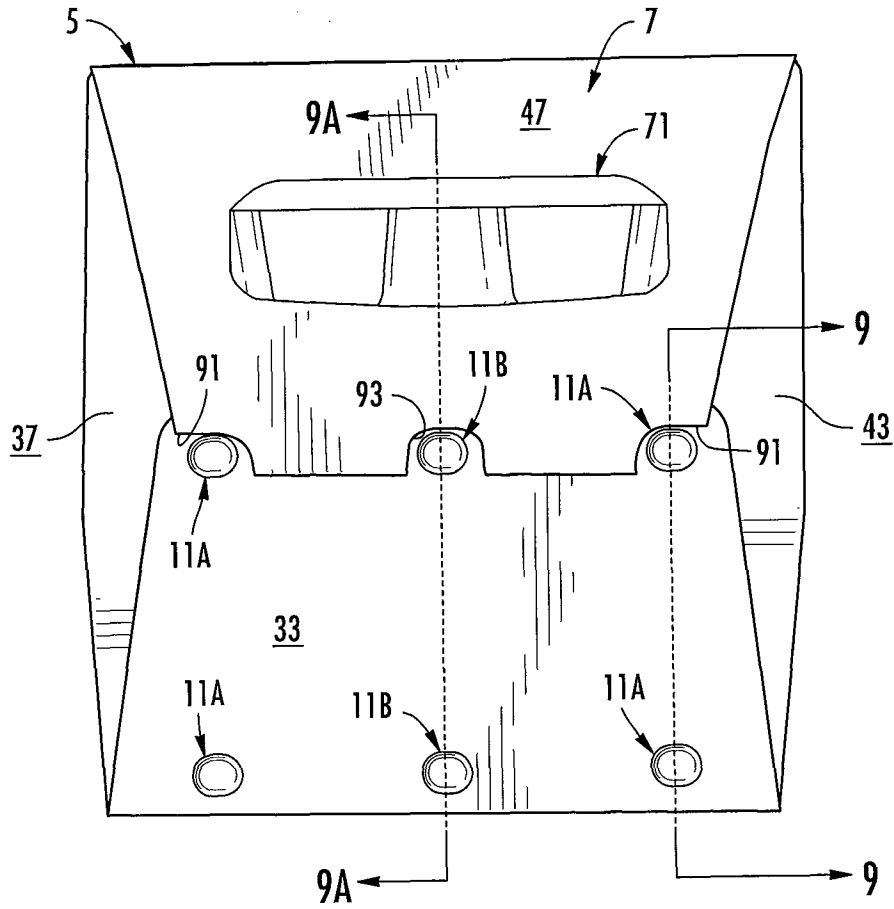

FIG. 8

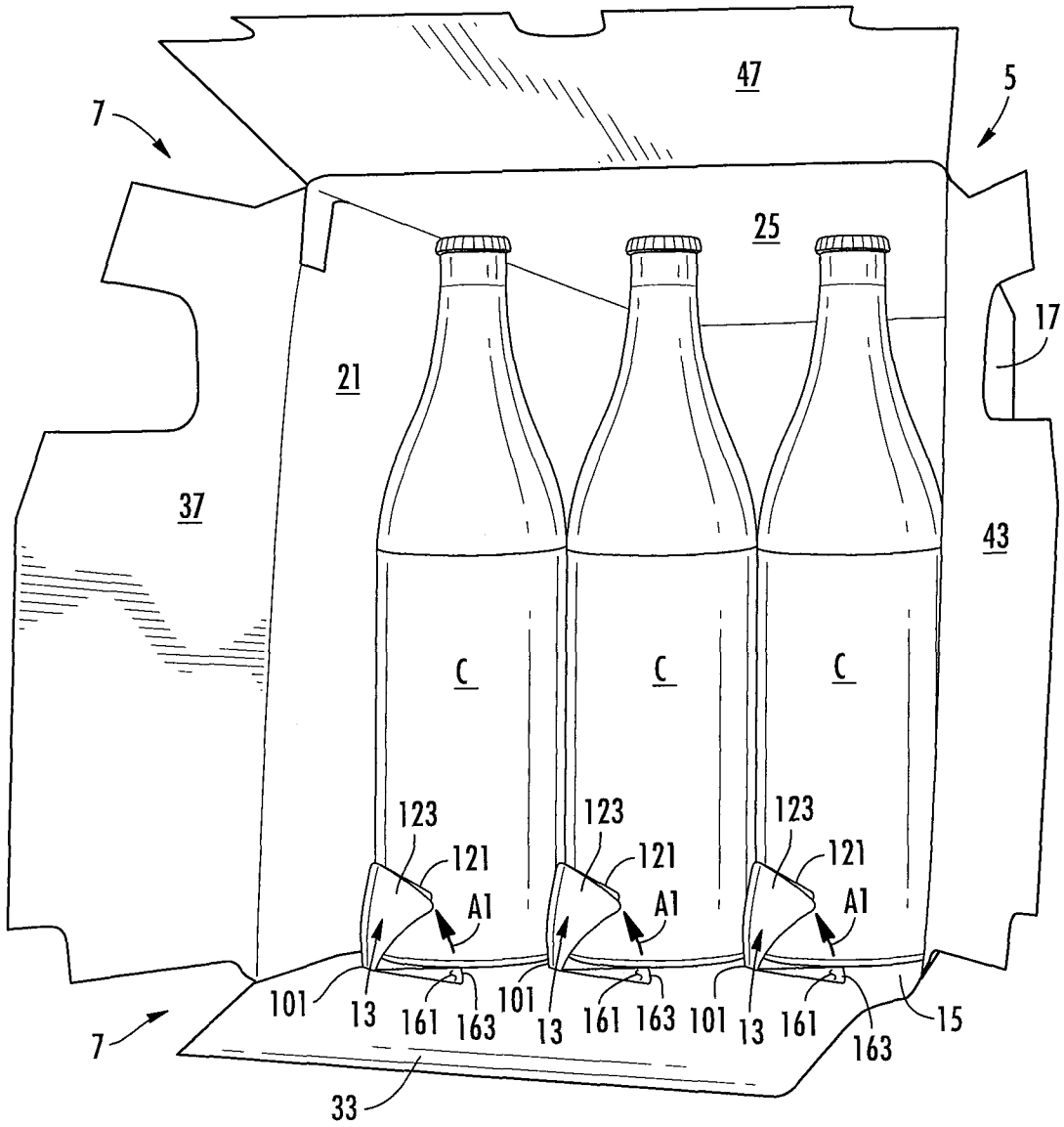
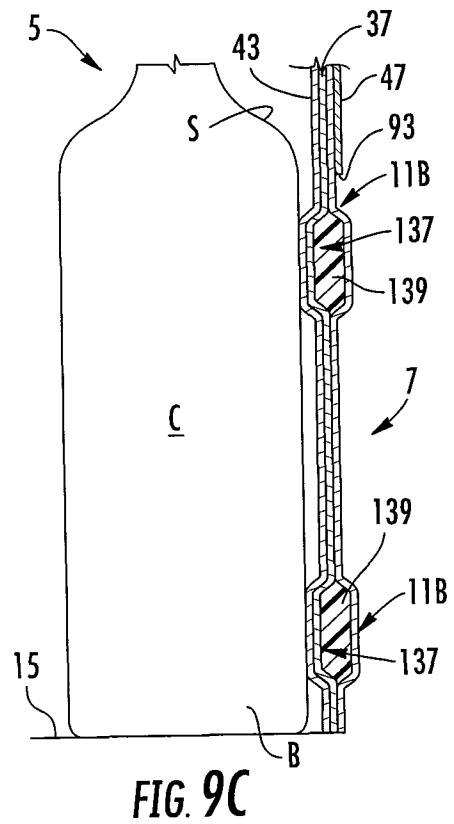
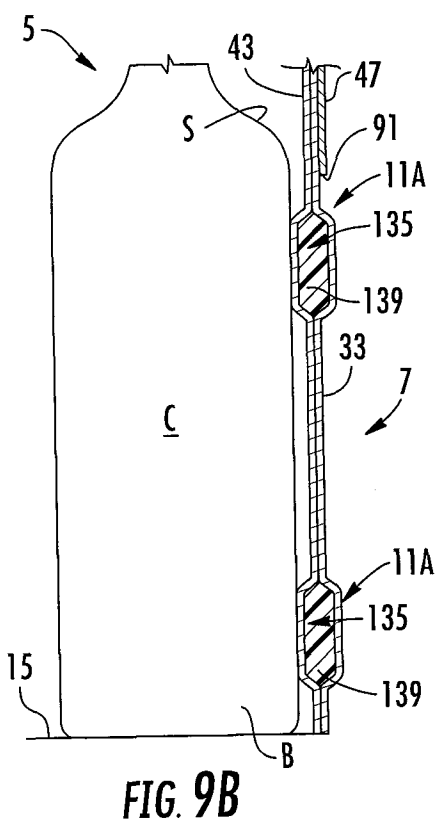
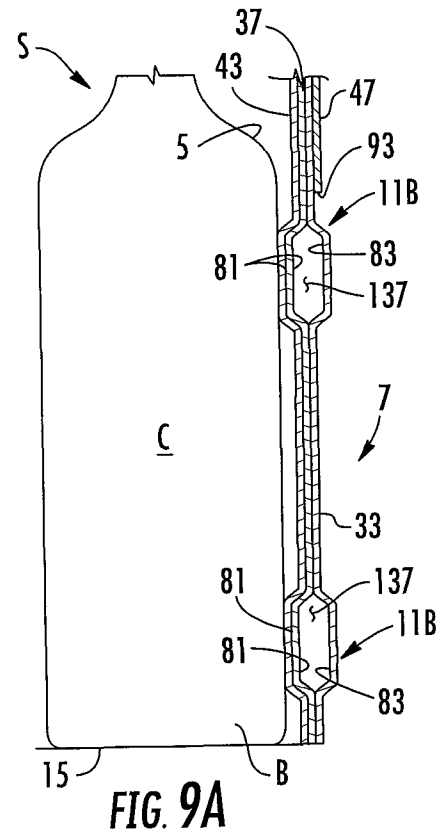
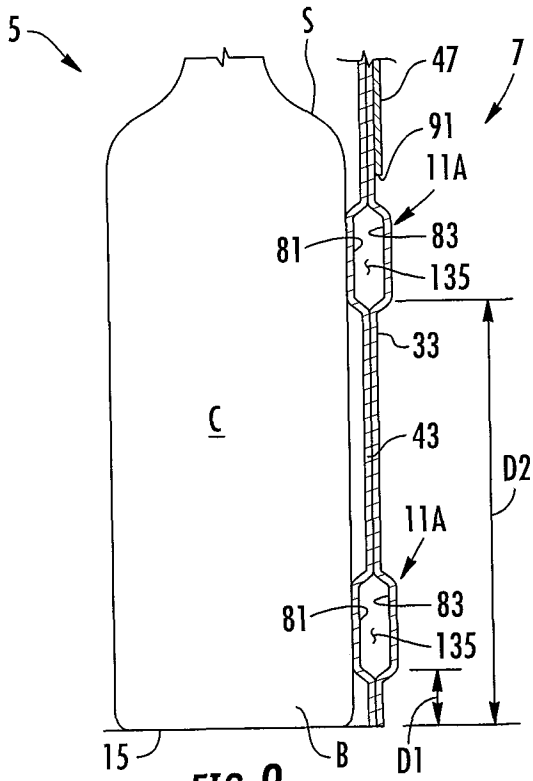

FIG. 8A



14/36

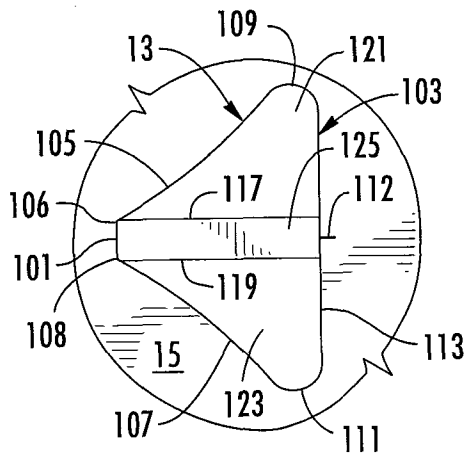

FIG. 10A

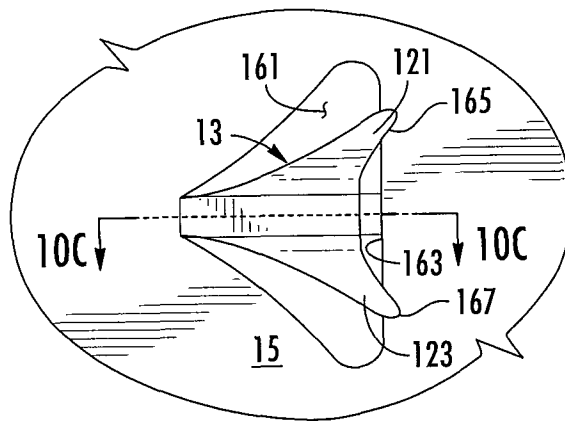

FIG. 10B

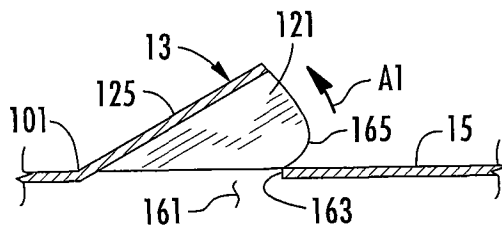

FIG. 10C

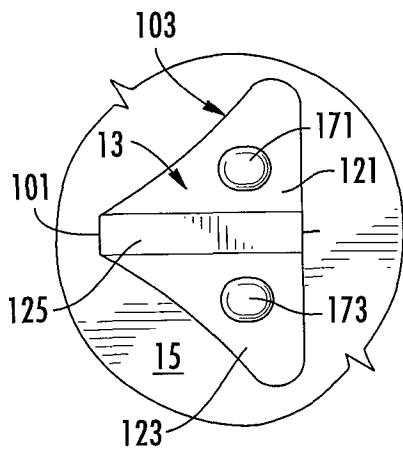

FIG. 10D

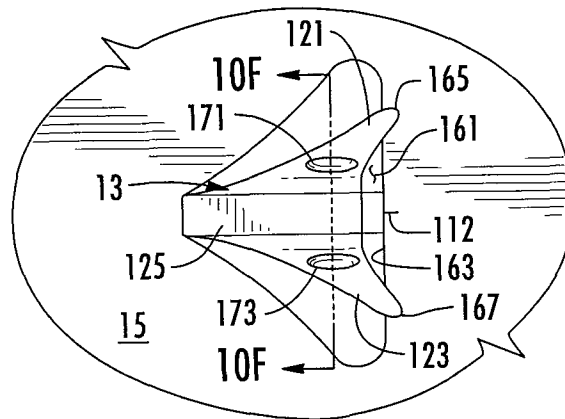

FIG. 10E

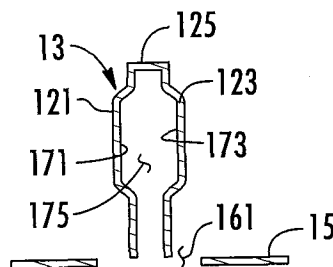
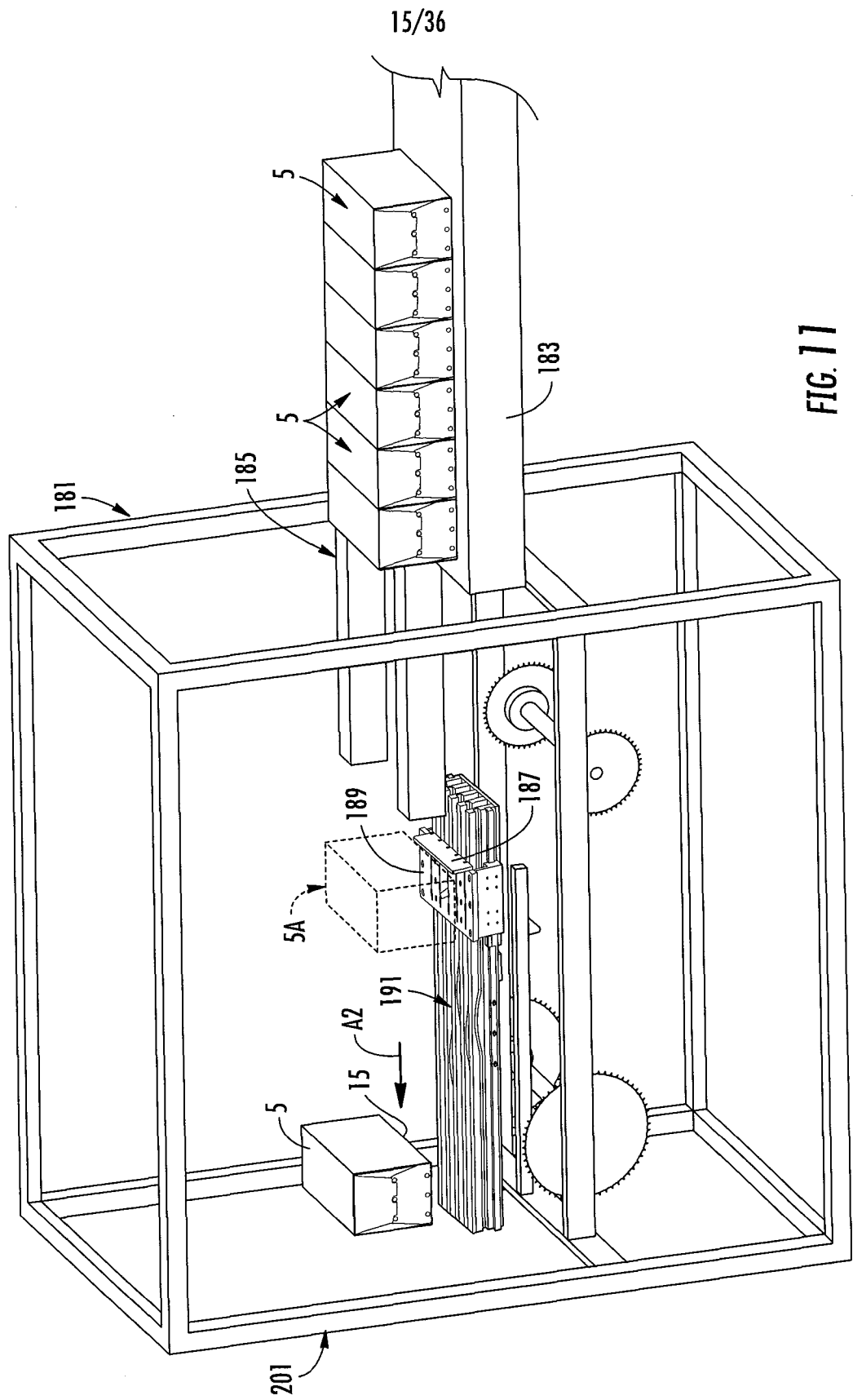

FIG. 10F



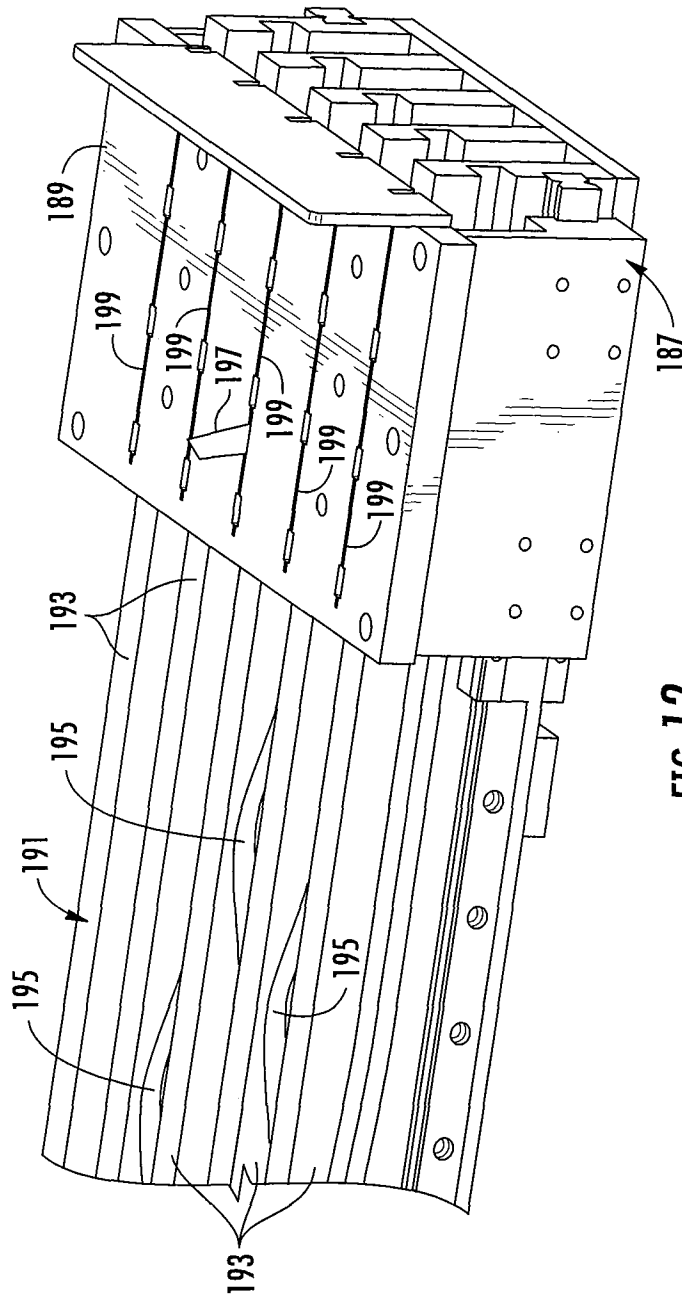

FIG. 12

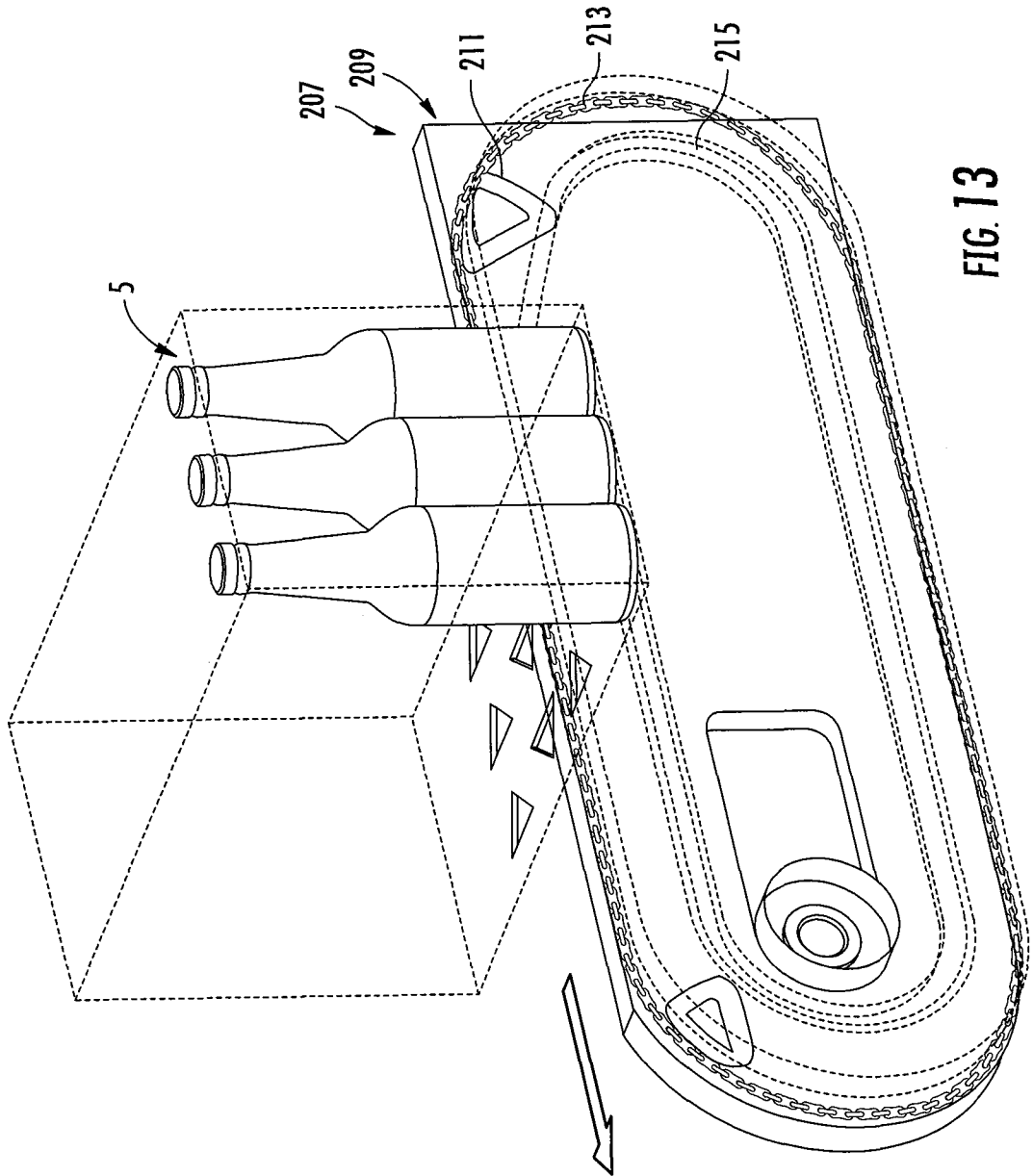

FIG. 13

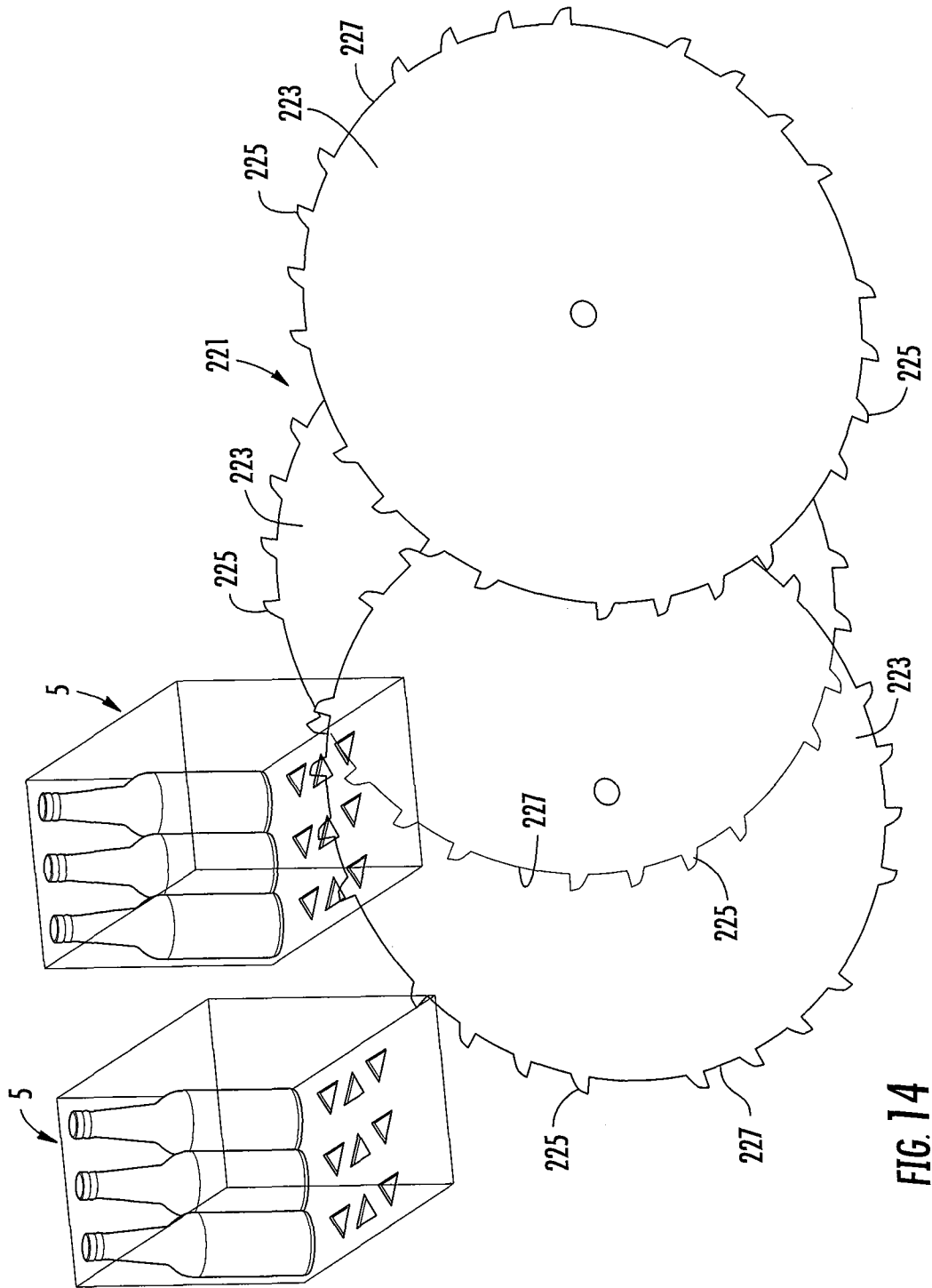

FIG. 14

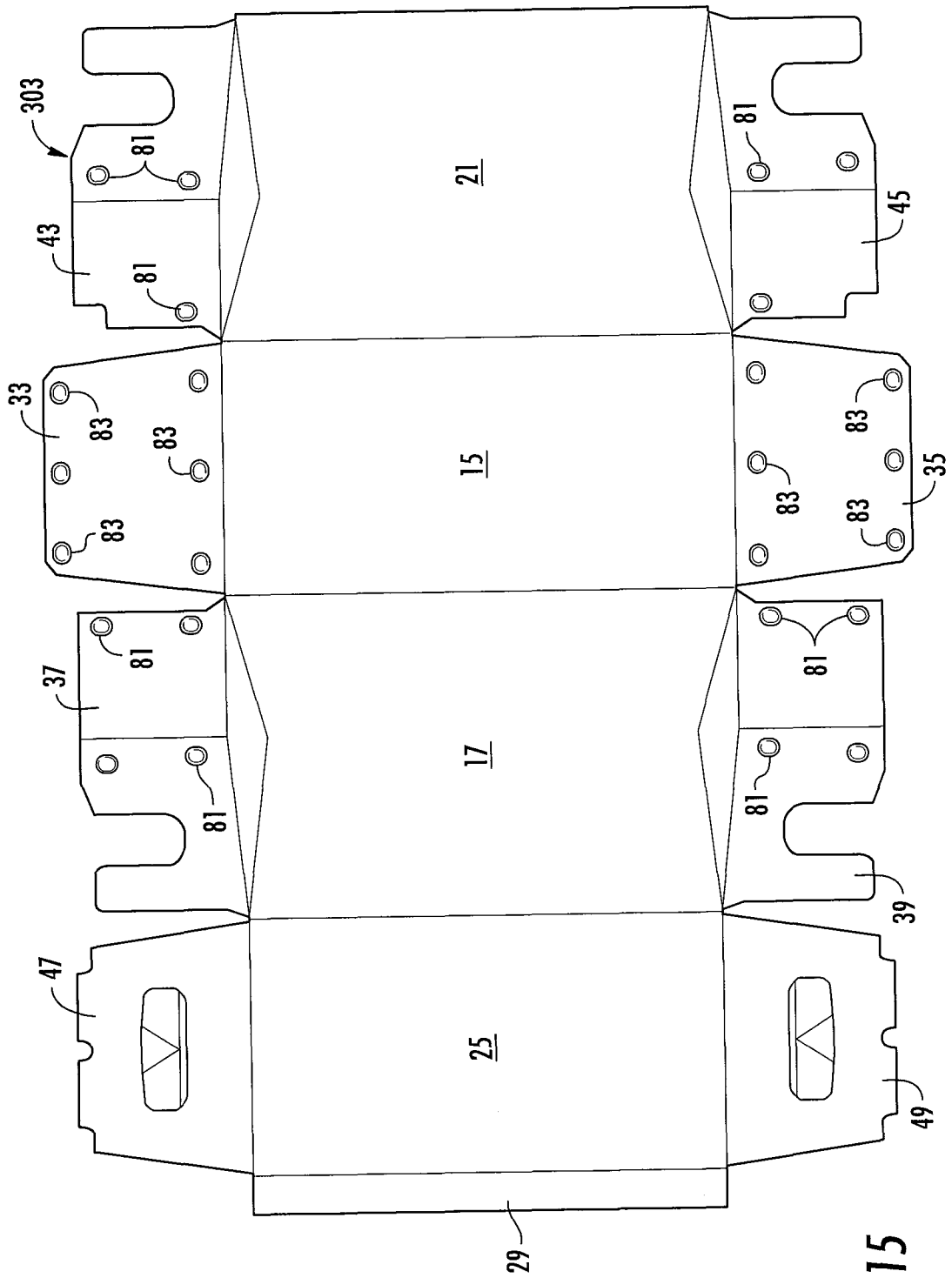

FIG. 15

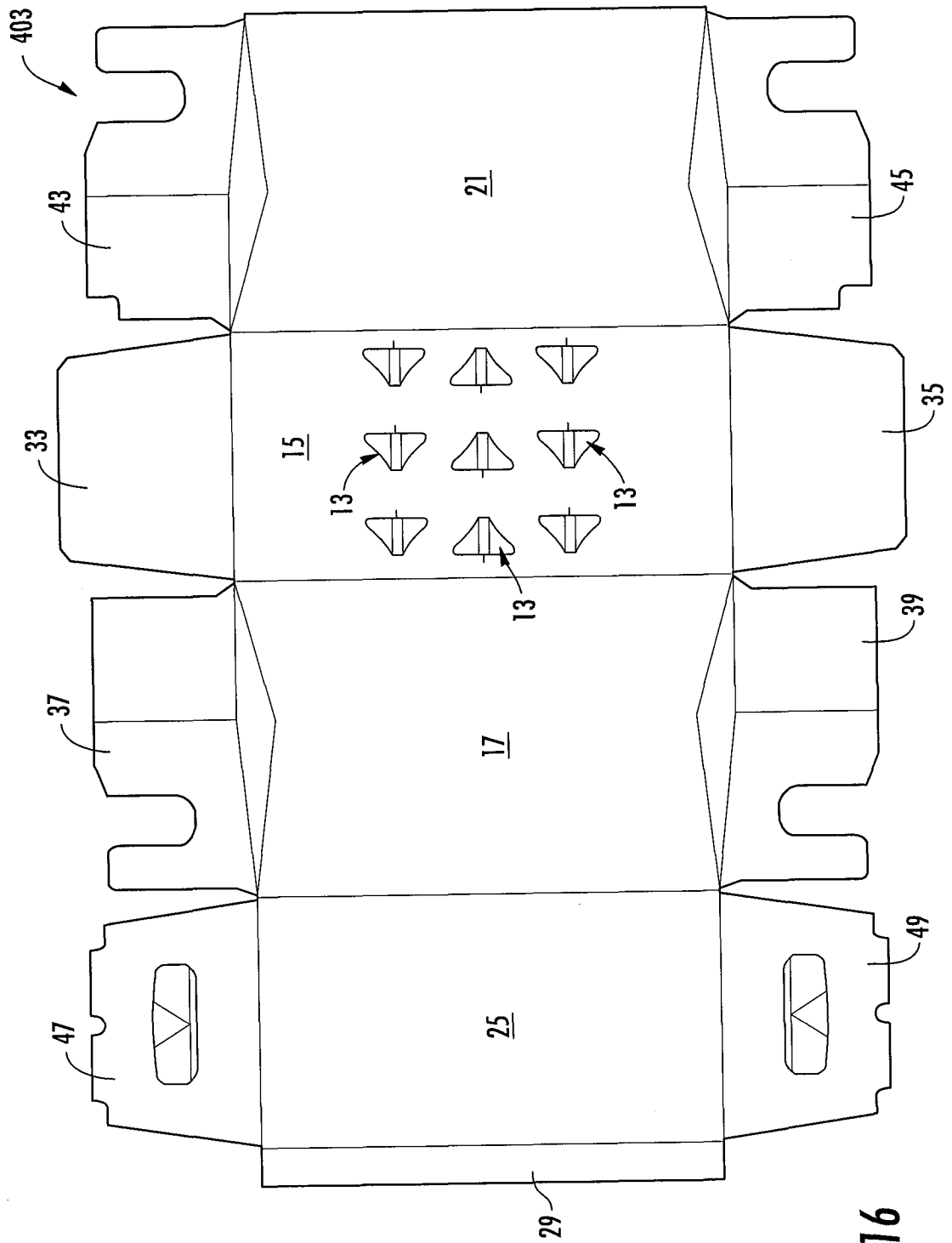

FIG. 16

21/36

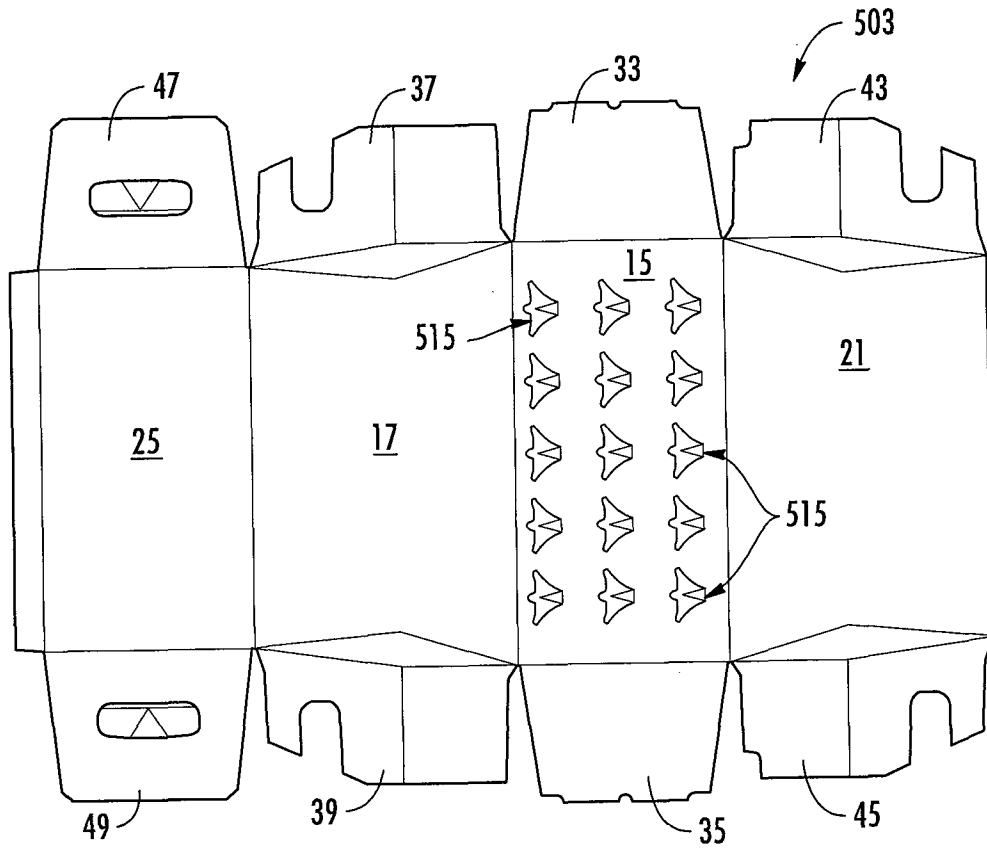

FIG. 17

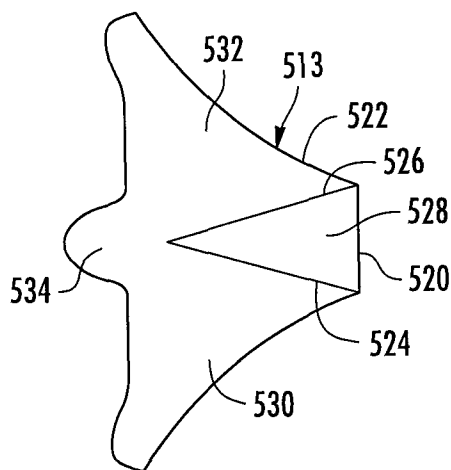

FIG. 17A

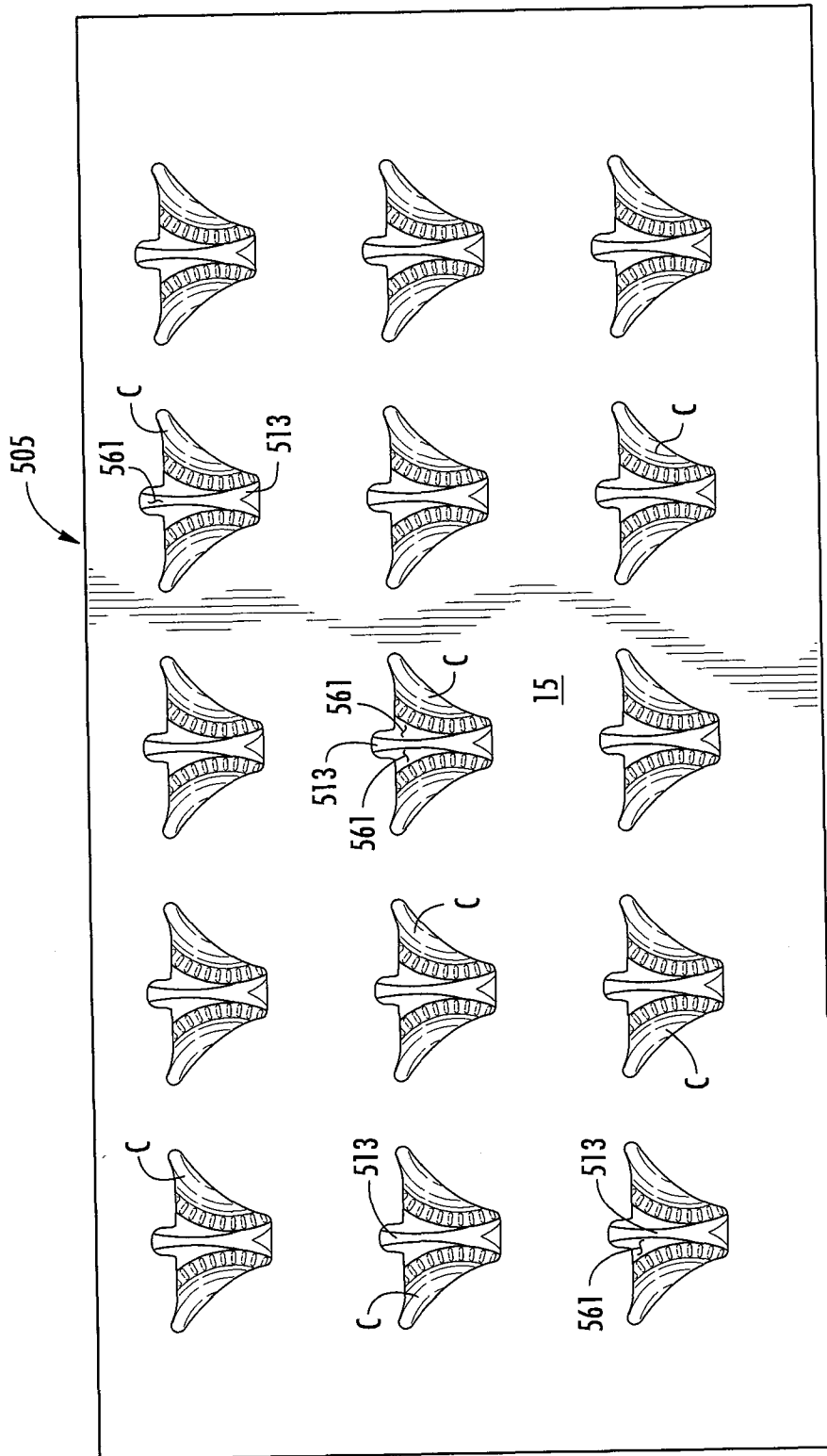

FIG. 18

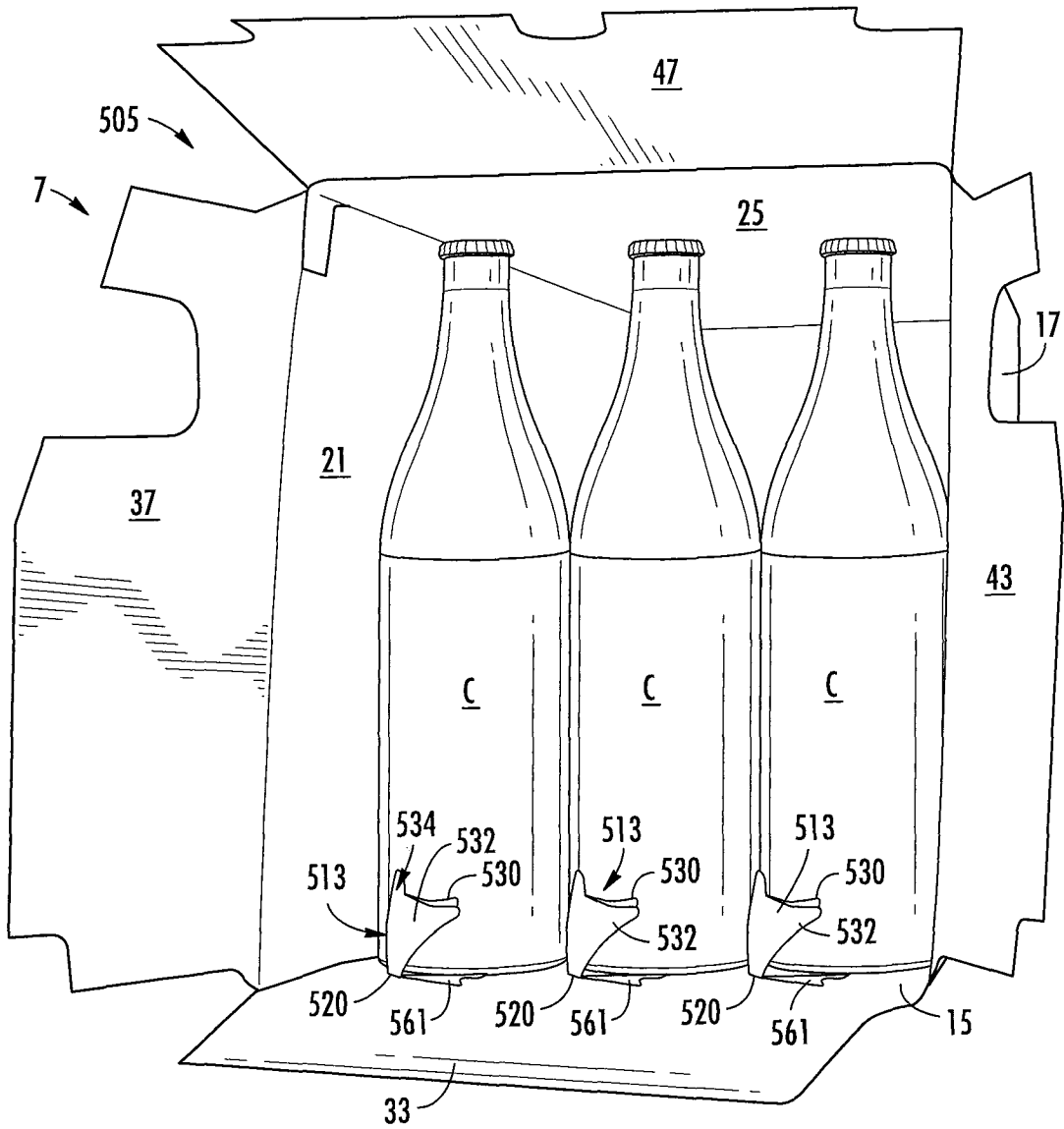

FIG. 19

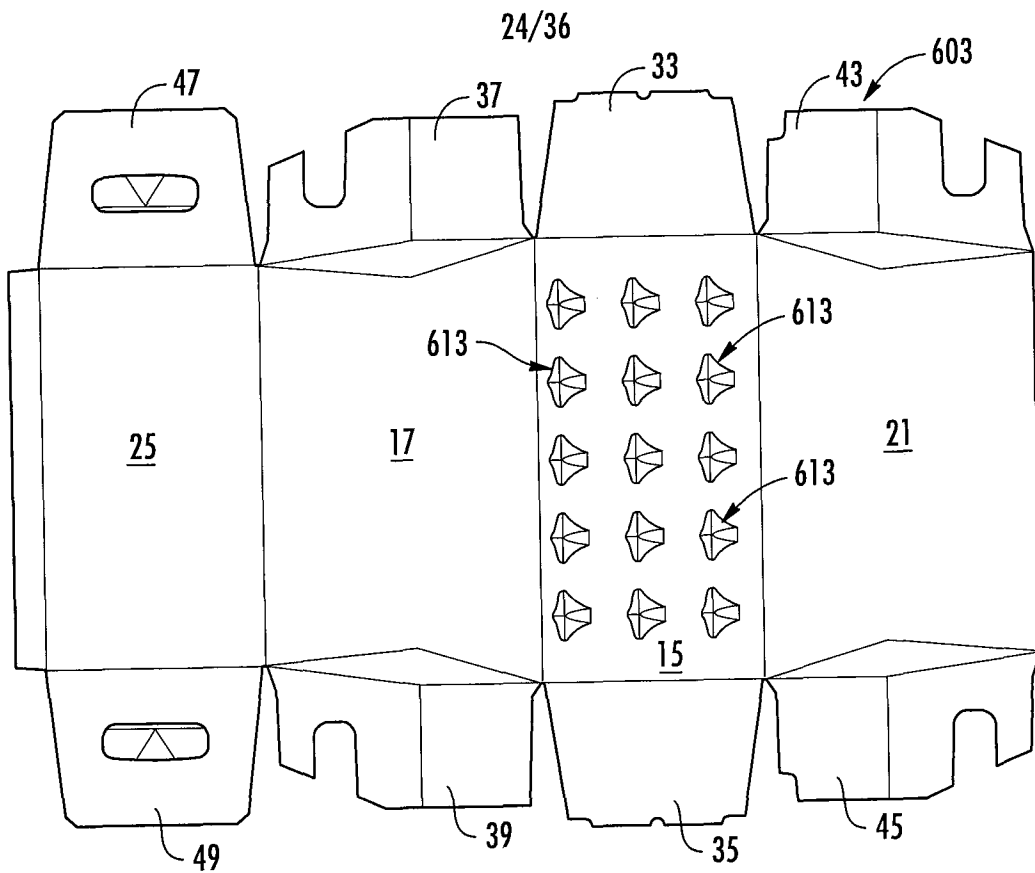

FIG. 20

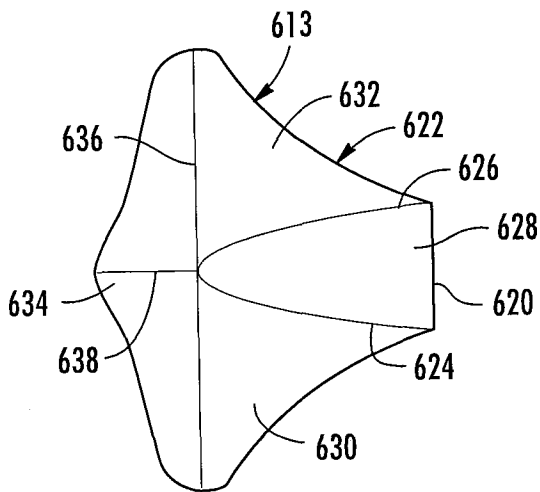

FIG. 20A

25/36

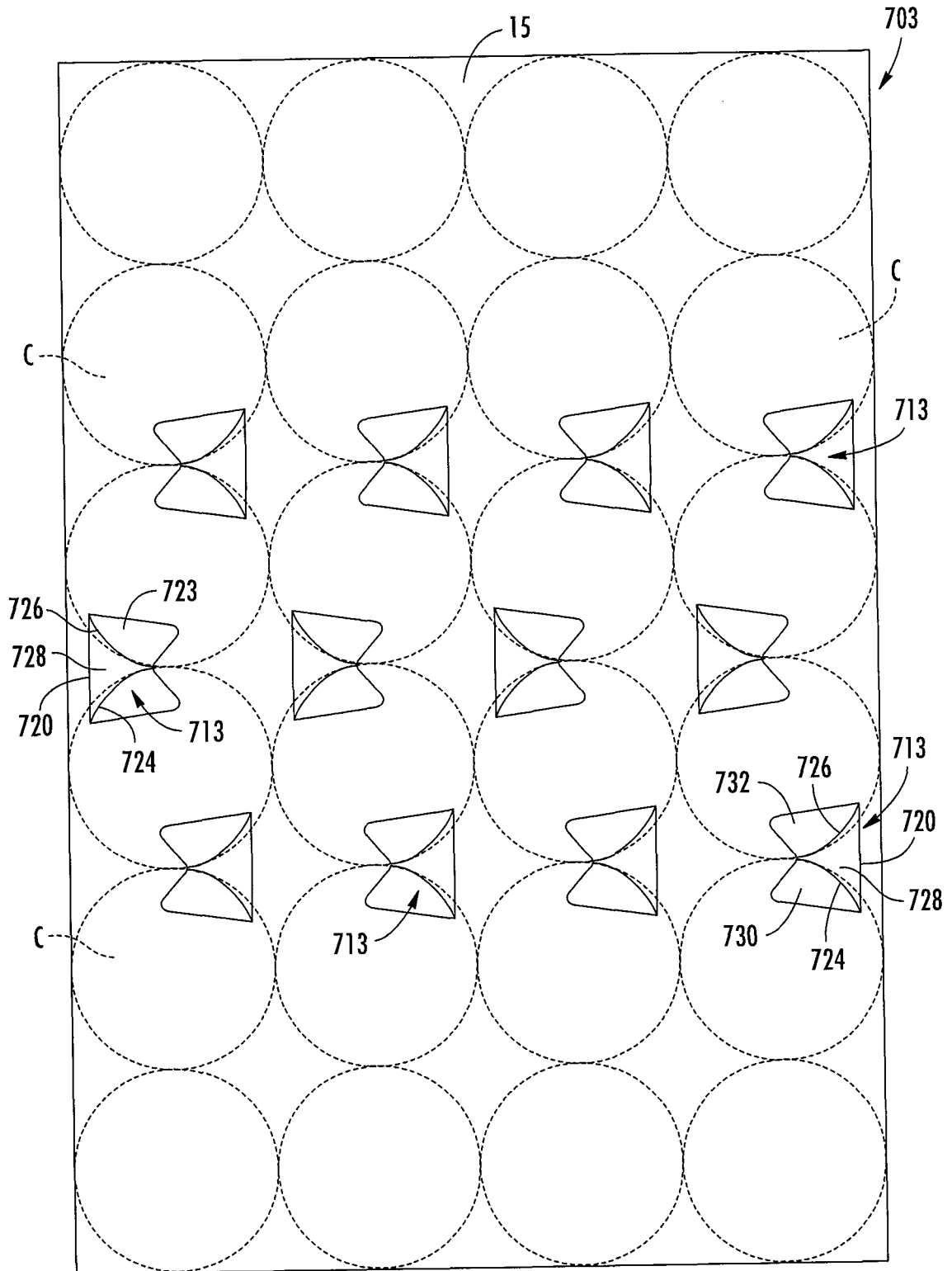

FIG. 21

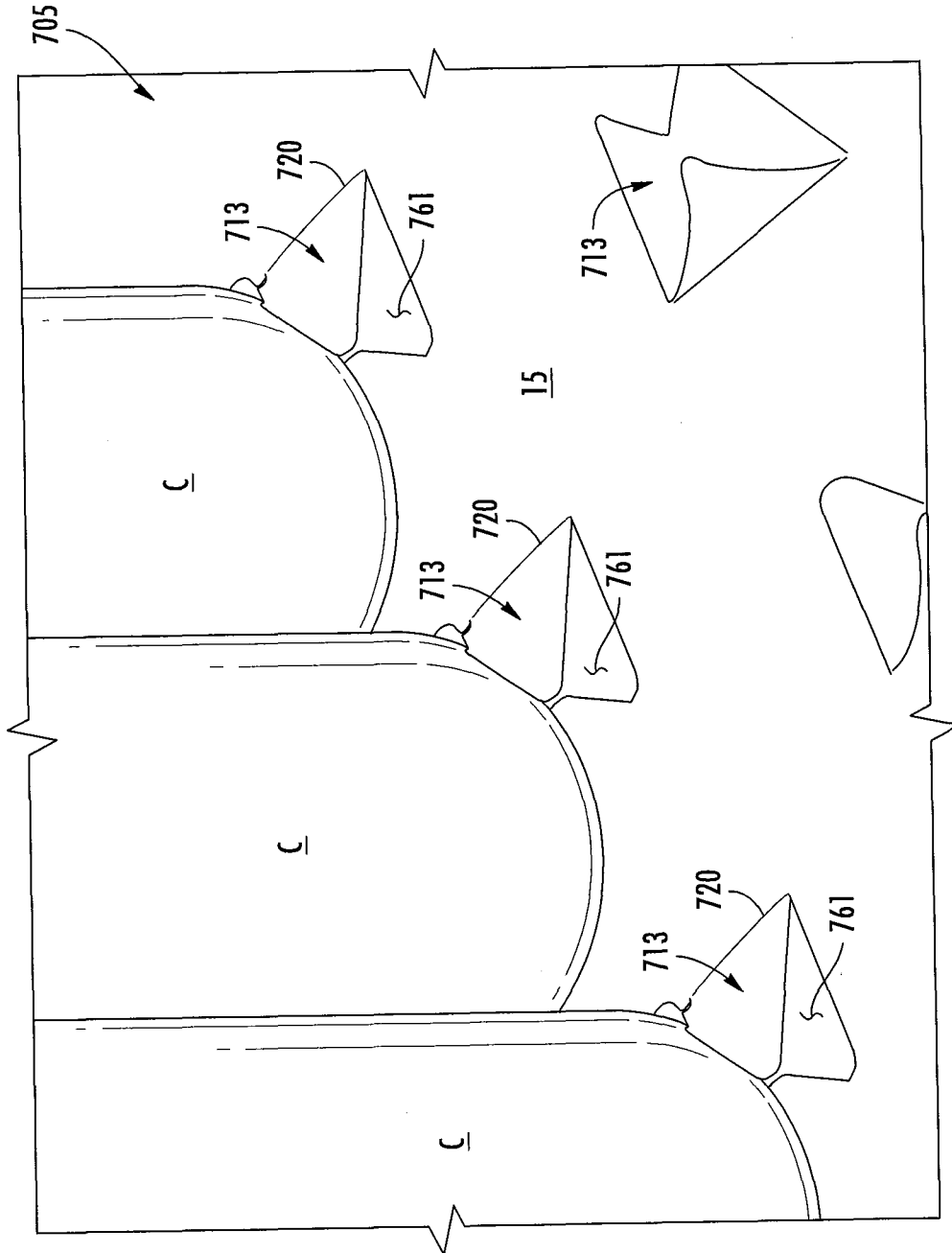

FIG. 22

27/36

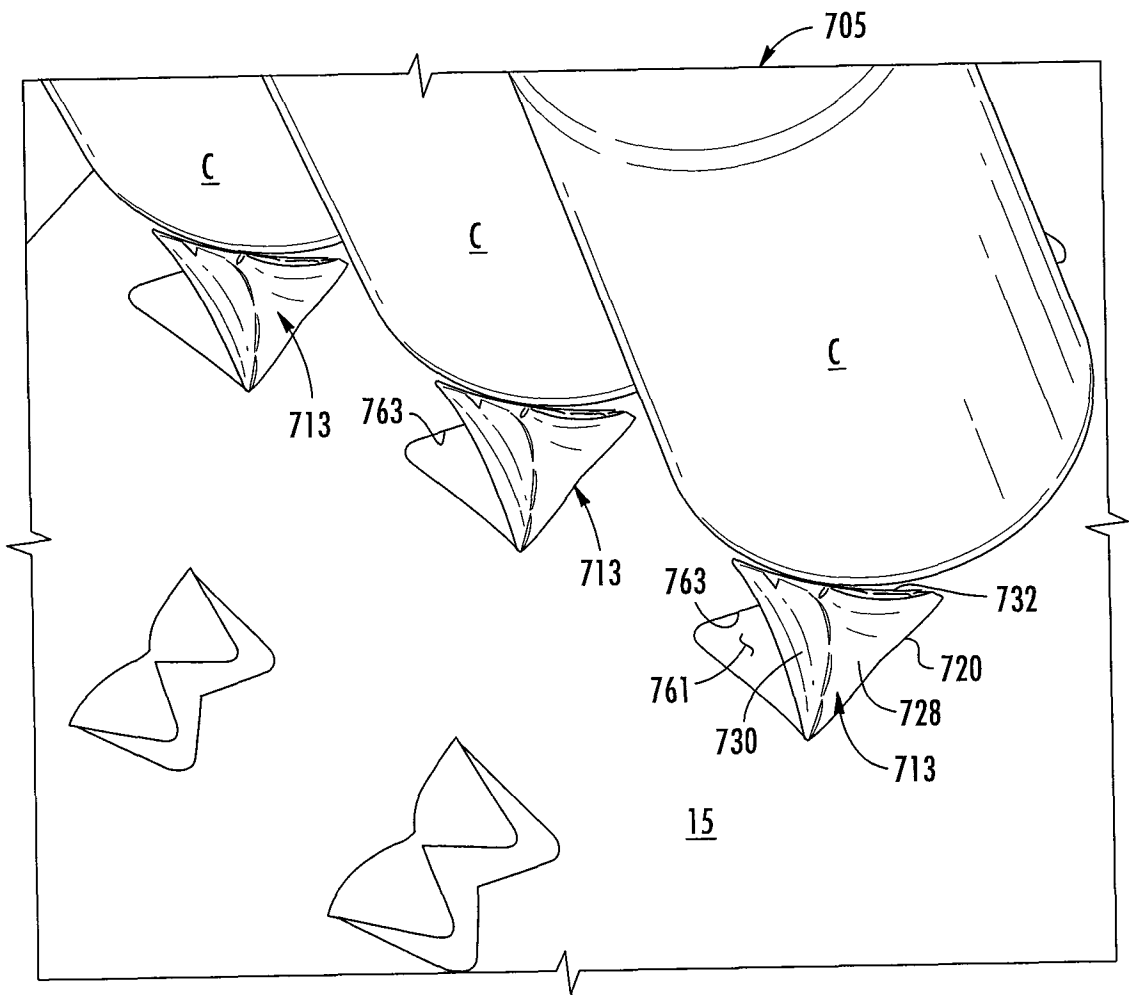

FIG. 23

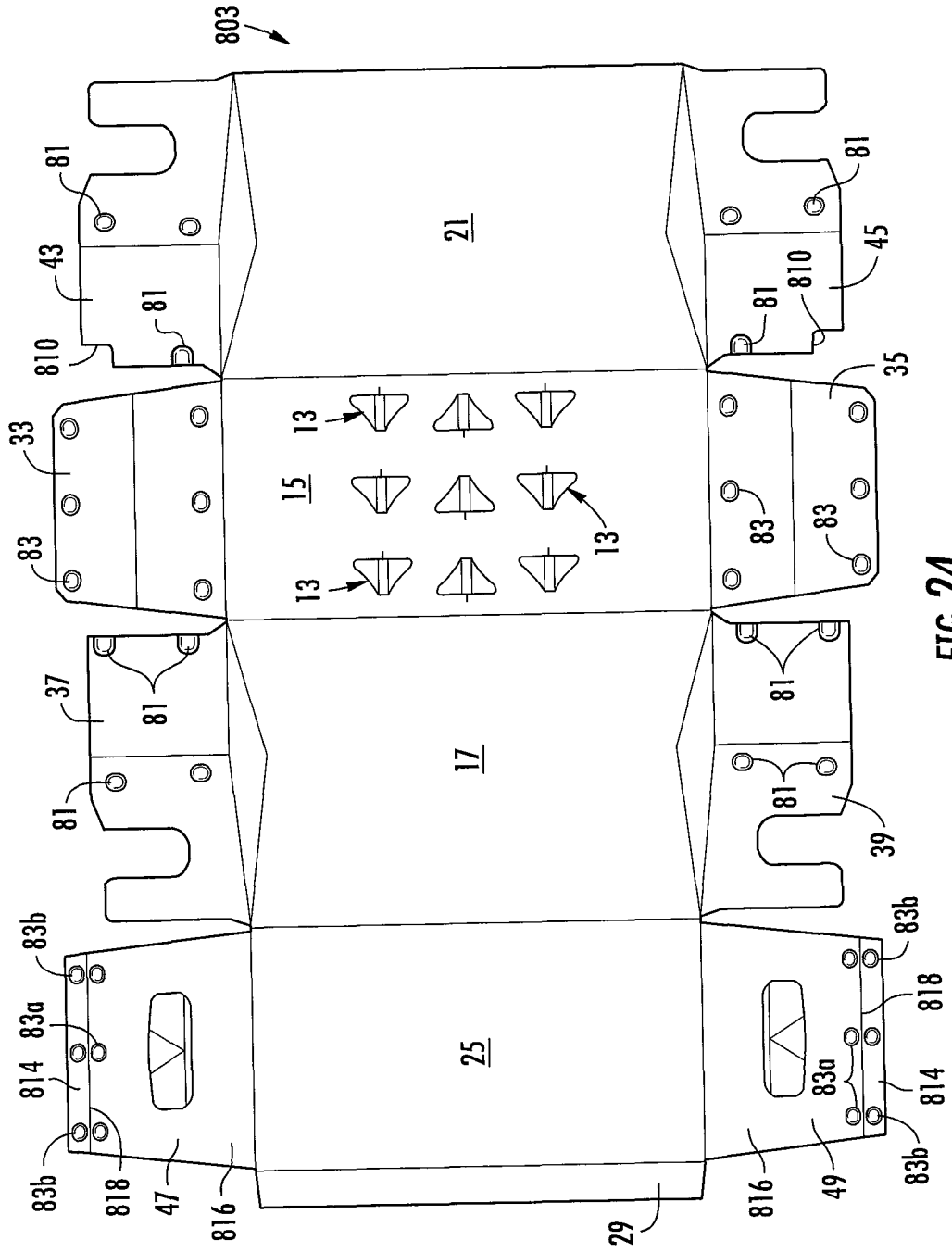

FIG. 24

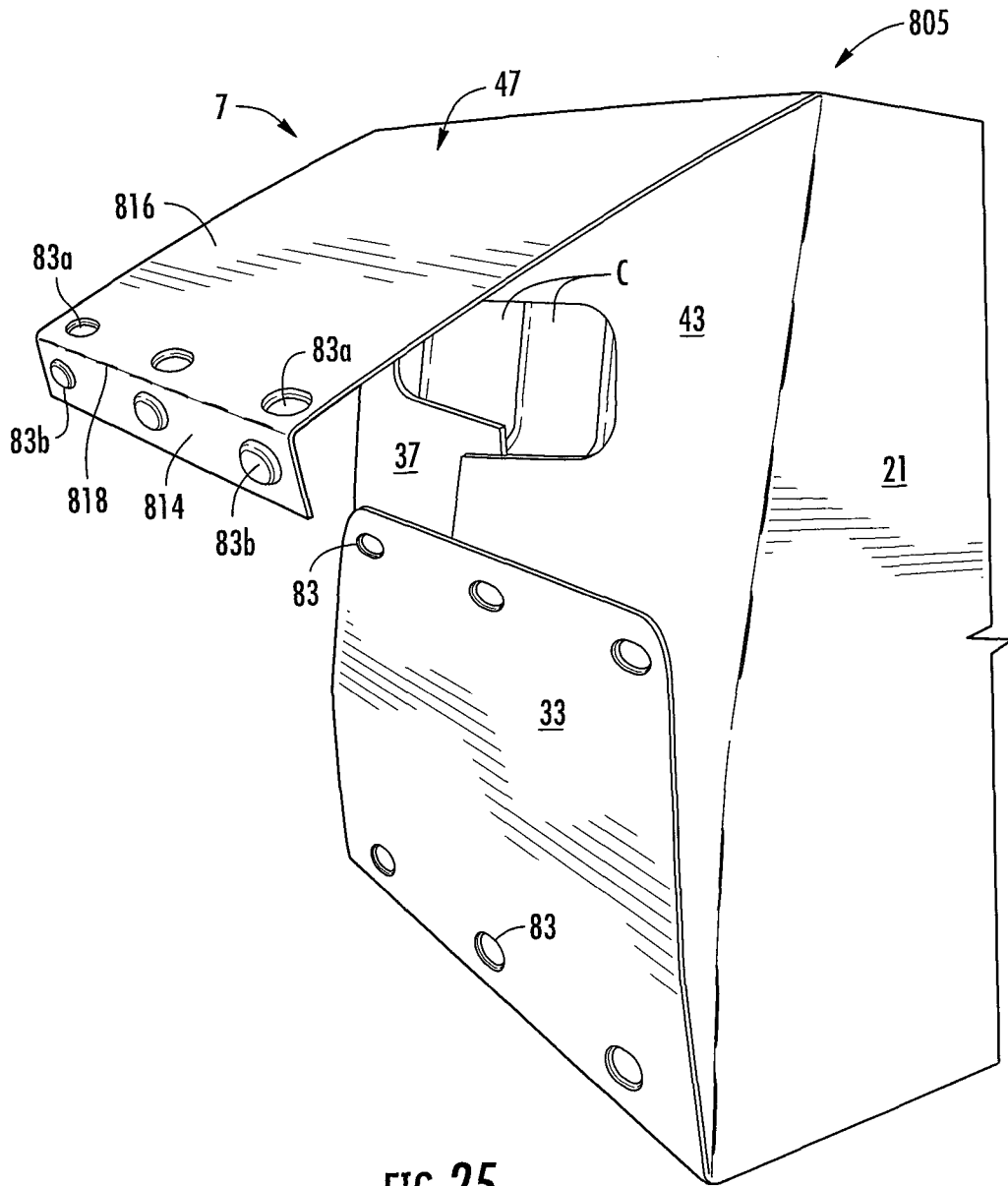

FIG. 25

30/36

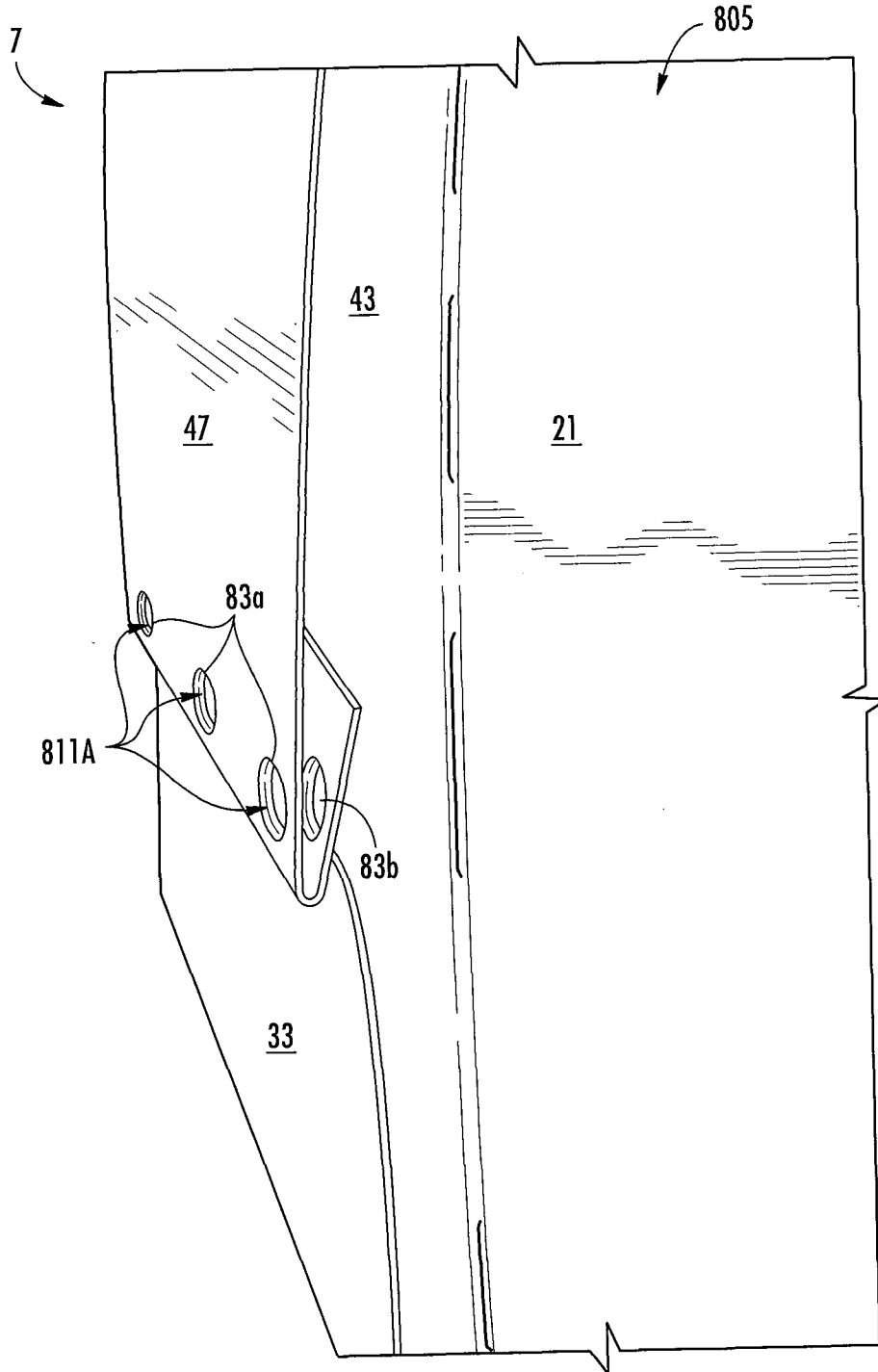

FIG. 26

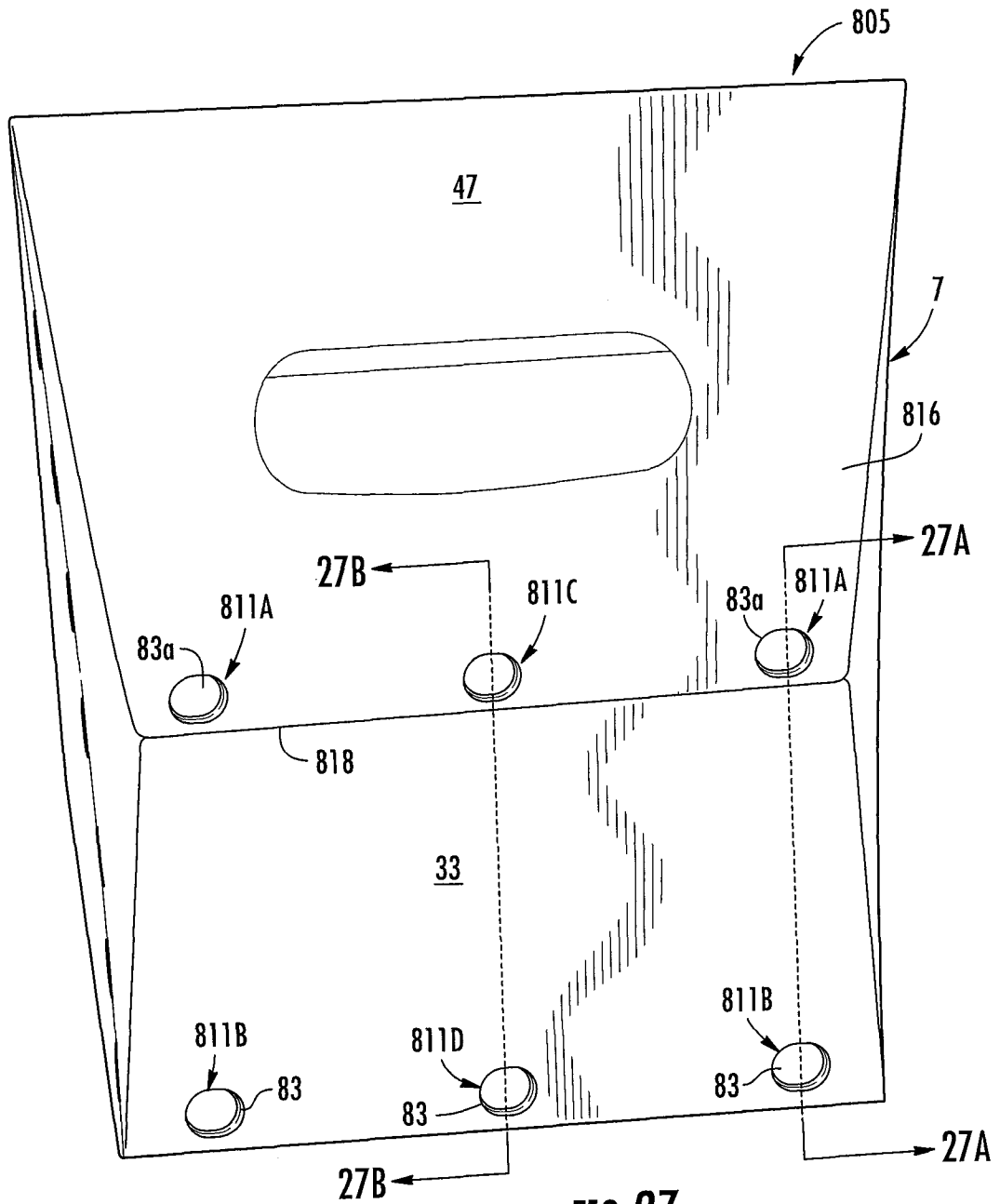

FIG. 27

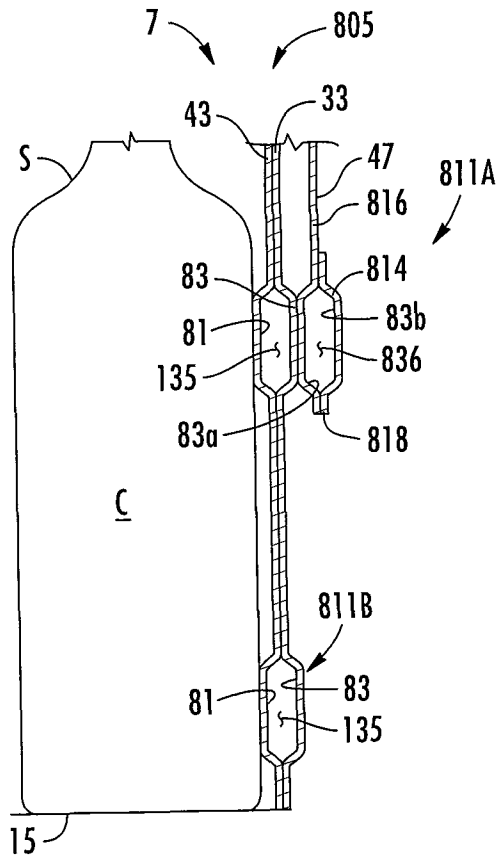

FIG. 27A

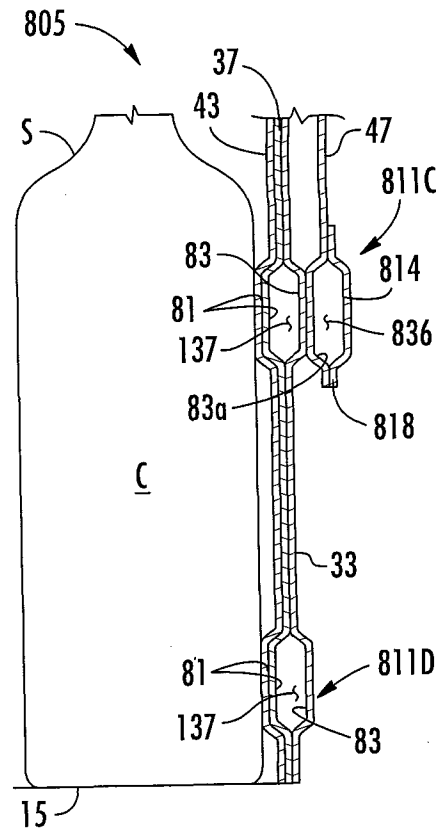

FIG. 27B

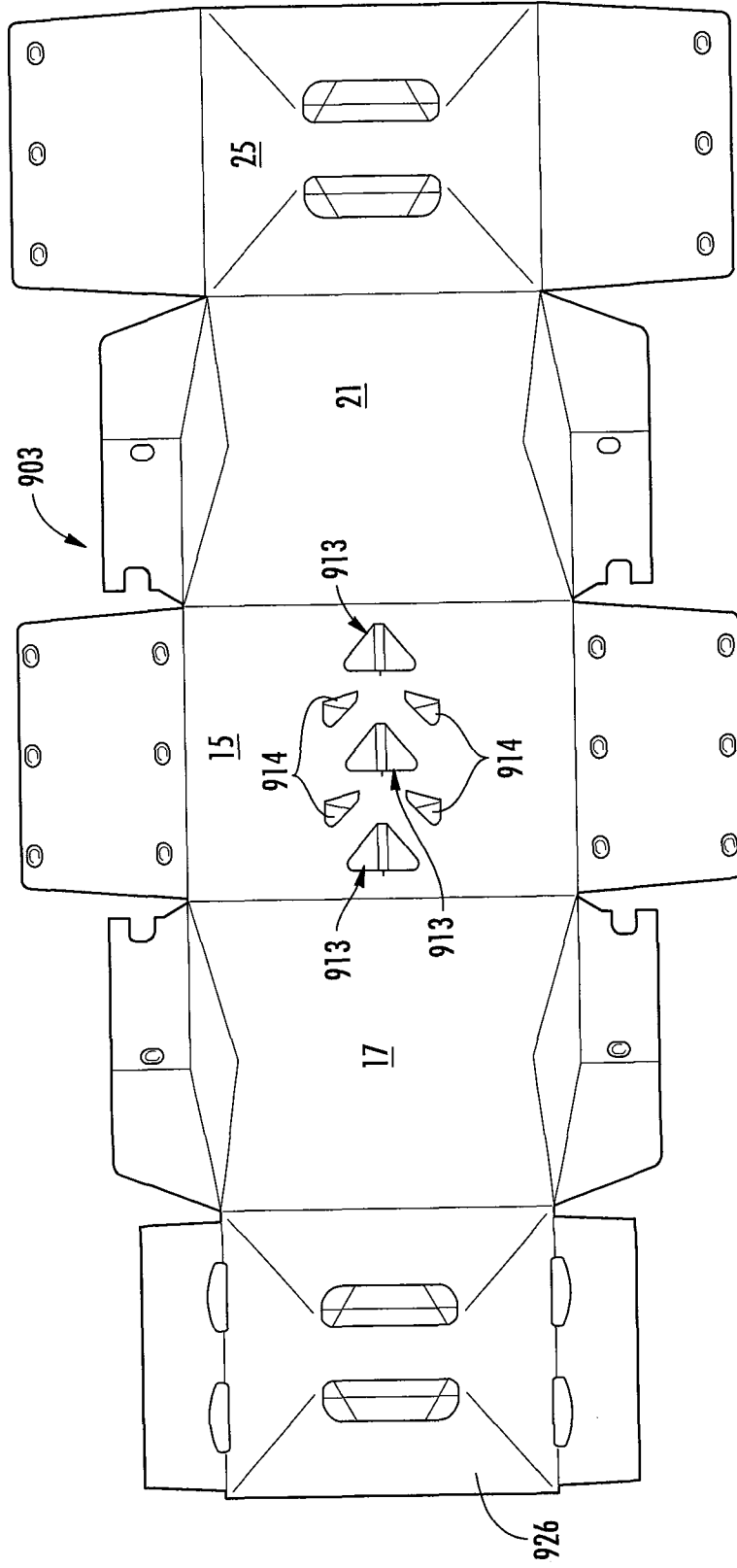

FIG. 28

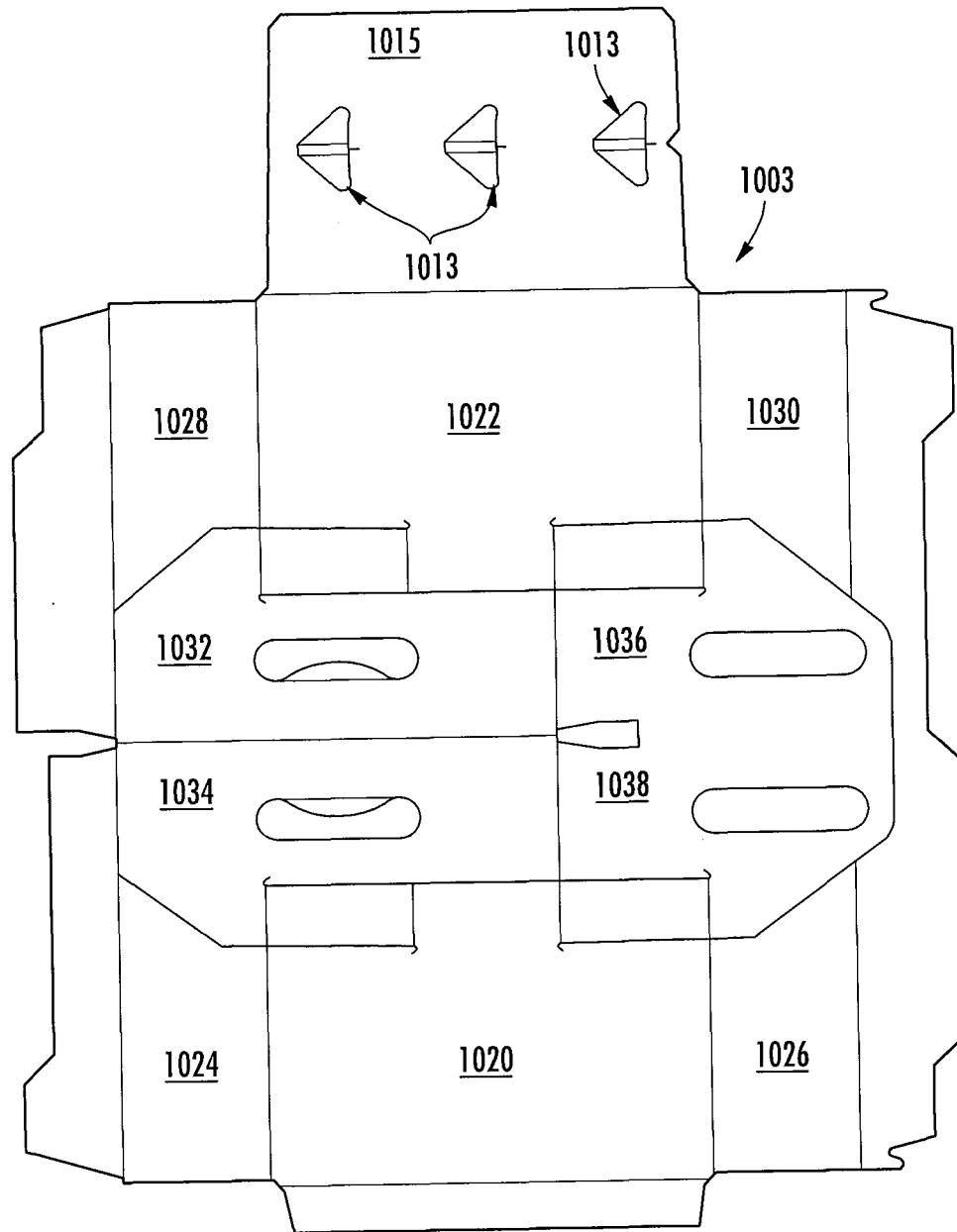

FIG. 29

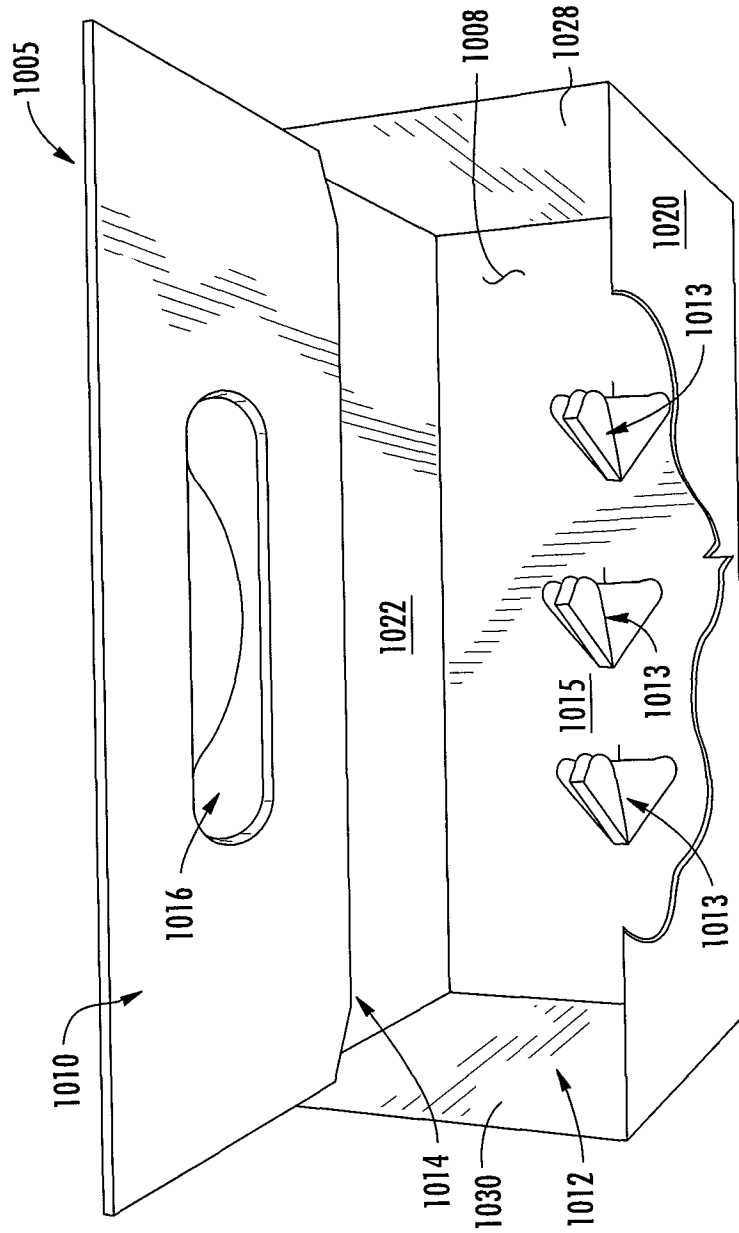

FIG. 30

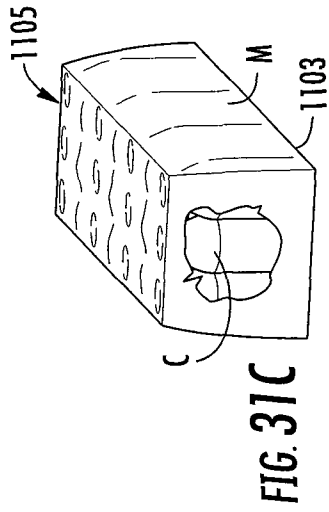

FIG. 31C

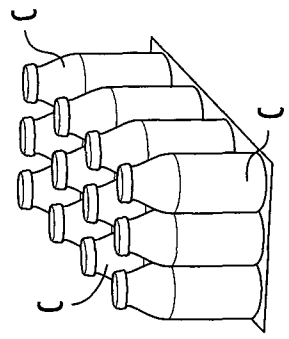

FIG. 31B

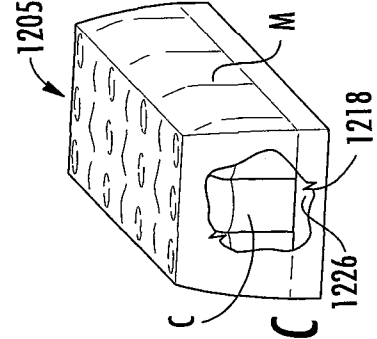

FIG. 32C

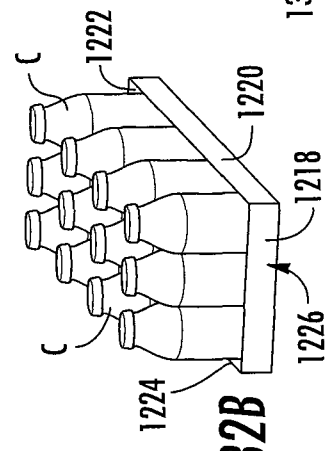

FIG. 32B

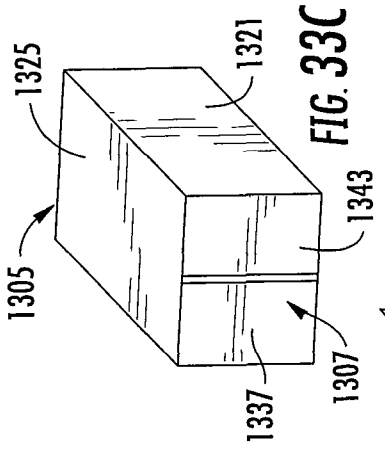

FIG. 33C

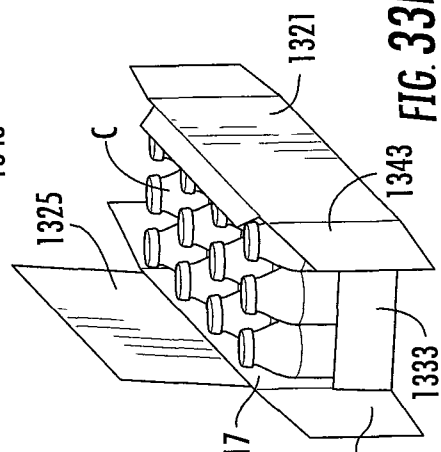

FIG. 33B

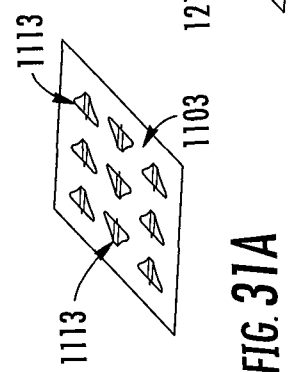

FIG. 31A

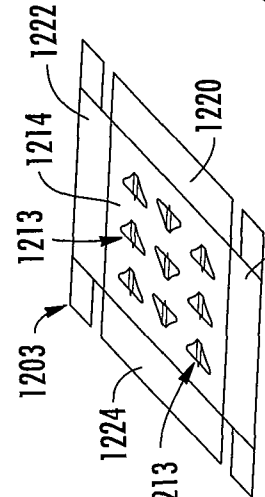

FIG. 32A

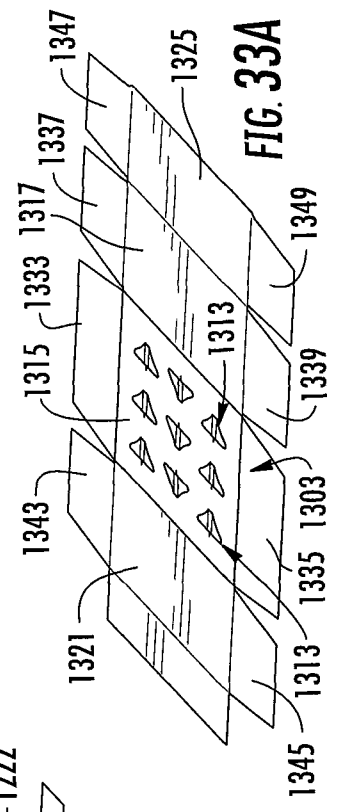

FIG. 33A

INTERNATIONAL SEARCH REPORT

International application No.
PCT/US2012/029022**A. CLASSIFICATION OF SUBJECT MATTER*****B65D 71/18(2006.01)i, B65D 71/34(2006.01)i, B65D 71/06(2006.01)i, B65D 81/05(2006.01)i***

According to International Patent Classification (IPC) or to both national classification and IPC

B. FIELDS SEARCHED

Minimum documentation searched (classification system followed by classification symbols)

B65D 71/18; B65D 65/00; B65D 71/14; B65D 81/02; B65D 71/24

Documentation searched other than minimum documentation to the extent that such documents are included in the fields searched

Korean utility models and applications for utility models
Japanese utility models and applications for utility models

Electronic data base consulted during the international search (name of data base and, where practicable, search terms used)

eKOMPASS(KIPO internal) & Keywords: protect, panel,

C. DOCUMENTS CONSIDERED TO BE RELEVANT

| Category* | Citation of document, with indication, where appropriate, of the relevant passages | Relevant to claim No. |
|-----------|--|-----------------------|
| A | WO 2011-049947 A1 (MEADWESTVACO PACKAGING SYSTEMS, LLC et al.) 28 April 2011 See abstract, page 1, line 15 - page 16, line 25; claims 1-11 and figures 1-9. | 1-171 |
| A | JP 3039805 B2 (RIVERWOOD NATURAL RESOURCES CORPORATION) 03 March 2000 See abstract, column 7, claims 1,4,5 and figure 2 | 1-171 |
| A | US 05002186A A (COOPER; LEONARD M.) 26 March 1991 See abstract, column 1, line 11 - column 5, line 5; claims 1-6 and figures 1-8. | 1-171 |
| A | US 04093068A A (SMRT; THOMAS J.) 06 June 1978 See abstract, column 1, line 60 - column 3, line 21; claim 1 and figures 1-7. | 1-171 |

 Further documents are listed in the continuation of Box C. See patent family annex.

* Special categories of cited documents:

"A" document defining the general state of the art which is not considered to be of particular relevance

"E" earlier application or patent but published on or after the international filing date

"L" document which may throw doubts on priority claim(s) or which is cited to establish the publication date of citation or other special reason (as specified)

"O" document referring to an oral disclosure, use, exhibition or other means

"P" document published prior to the international filing date but later than the priority date claimed

"T" later document published after the international filing date or priority date and not in conflict with the application but cited to understand the principle or theory underlying the invention

"X" document of particular relevance; the claimed invention cannot be considered novel or cannot be considered to involve an inventive step when the document is taken alone

"Y" document of particular relevance; the claimed invention cannot be considered to involve an inventive step when the document is combined with one or more other such documents, such combination being obvious to a person skilled in the art

"&" document member of the same patent family

Date of the actual completion of the international search

25 SEPTEMBER 2012 (25.09.2012)

Date of mailing of the international search report

26 SEPTEMBER 2012 (26.09.2012)

Name and mailing address of the ISA/KR

Korean Intellectual Property Office
189 Cheongsa-ro, Seo-gu, Daejeon Metropolitan
City, 302-701, Republic of Korea

Facsimile No. 82-42-472-7140

Authorized officer

LEE, Se Gyoung

Telephone No. 82-42-481-5410



INTERNATIONAL SEARCH REPORT

Information on patent family members

International application No.

PCT/US2012/029022

| Patent document cited in search report | Publication date | Patent family member(s) | Publication date |
|--|------------------|-------------------------|------------------|
| WO 2011-049947 A1 | 28.04.2011 | EP 2490961 A1 | 29.08.2012 |
| | | GB 0918250 D0 | 02.12.2009 |
| | | KR 10-2012-0098634 A | 05.09.2012 |
| JP 3039805 B2 | 03.03.2000 | AT 121362 T | 15.05.1995 |
| | | AU 638622 B2 | 01.07.1993 |
| | | AU 9076491 A | 25.06.1992 |
| | | BR 9106210 A | 30.03.1993 |
| | | CA 2074528 A1 | 22.05.1992 |
| | | CA 2074528 C | 13.05.2003 |
| | | DE 69109097 D1 | 24.05.1995 |
| | | DE 69109097 T2 | 31.08.1995 |
| | | DK0515648T3 | 03.07.1995 |
| | | EP 0515648 A1 | 02.12.1992 |
| | | EP 0515648 B1 | 19.04.1995 |
| | | ES 2071482 T3 | 16.06.1995 |
| | | F1923301A | 20.07.1992 |
| | | F1923301D0 | 20.07.1992 |
| | | IE914036A1 | 03.06.1992 |
| | | JP 5508140 T | 18.11.1993 |
| | | JP H055-08140-08140 | 18.11.1993 |
| | | KR 10-1992-0703414 A | 17.12.1992 |
| | | N0922873A | 20.07.1992 |
| | | N0922873D0 | 20.07.1992 |
| | | NZ240669A | 26.05.1993 |
| | | US 05107986A A | 28.04.1992 |
| | | WO 92-09498 A1 | 11.06.1992 |
| WO 92-09498A1 | 11.06.1992 | | |
| ZA9109180A | 26.08.1992 | | |
| US 05002186A A | 26.03.1991 | CA 2080702 C | 24.07.2001 |
| | | EP 0525061 A1 | 03.02.1993 |
| | | EP 0525061 B1 | 28.06.1995 |
| | | JP 03-043806 B2 | 10.03.2000 |
| | | JP 3043806 B2 | 22.05.2000 |
| | | KR 10-1993-0700338 A | 13.03.1993 |
| | | WO 91-16244 A1 | 31.10.1991 |
| US 04093068A A | 06.06.1978 | None | |