

(19)  
(12)

(KR)  
(Y1)

(51) 。 Int. Cl. <sup>6</sup>  
B60R 9/04

(45)  
(11)  
(24)

2002 04 15  
20 - 0272341  
2002 04 04

---

(21) 20 - 1999 - 0009481  
(22) 1999 05 31

(65) 2000 - 0021595  
(43) 2000 12 26

---

(73)

2 1245 - 3

(72)

2525

101 302

(74)

:

---

(54)

---

1

1

2

3

4

가

가

가

가

가

가

가

1

(2)

(4) ,  
가

(2)

(4)

(6)

(6)

가

(5)  
(4)

(8)

(22)  
(10)

(2)

(18)

(2)

(8)가  
(12)가

(8)

(14)  
가

(12)  
(22)

(18)

(12)  
(2)

(24)

(22) 가 (22)

(2) 1 4 1 (24) (12)  
(2)

(12) (20) 2 (12)

(18) (12) (20) (12)

3 (24) (2)가 (6)  
(6) (4) (8)가

(2) (6) (24)

(2) (12) (14) (4)가  
(16) (18) (22) (18)  
(12)

(22) (24) 4 (12) (18)  
(2) (6)

(12) (18) (22) (14) (2)  
(8)가 (22) (12) (12)

(12) (14) (2) (8) 가  
(10) (12) (24) (18) (22) (10)  
(8) (24) (12)

4 (12) (2)가 (12) (12) (12)  
(10) 가 가

(12) (2) (24) (24) (2) (2)  
(12) (6) (2) (6) (2) (2)  
(24)

(4) (5) (24)  
가

가

(57)

1.

2.

( )

3.

1

4.

1

5.

1

1

6.

( )

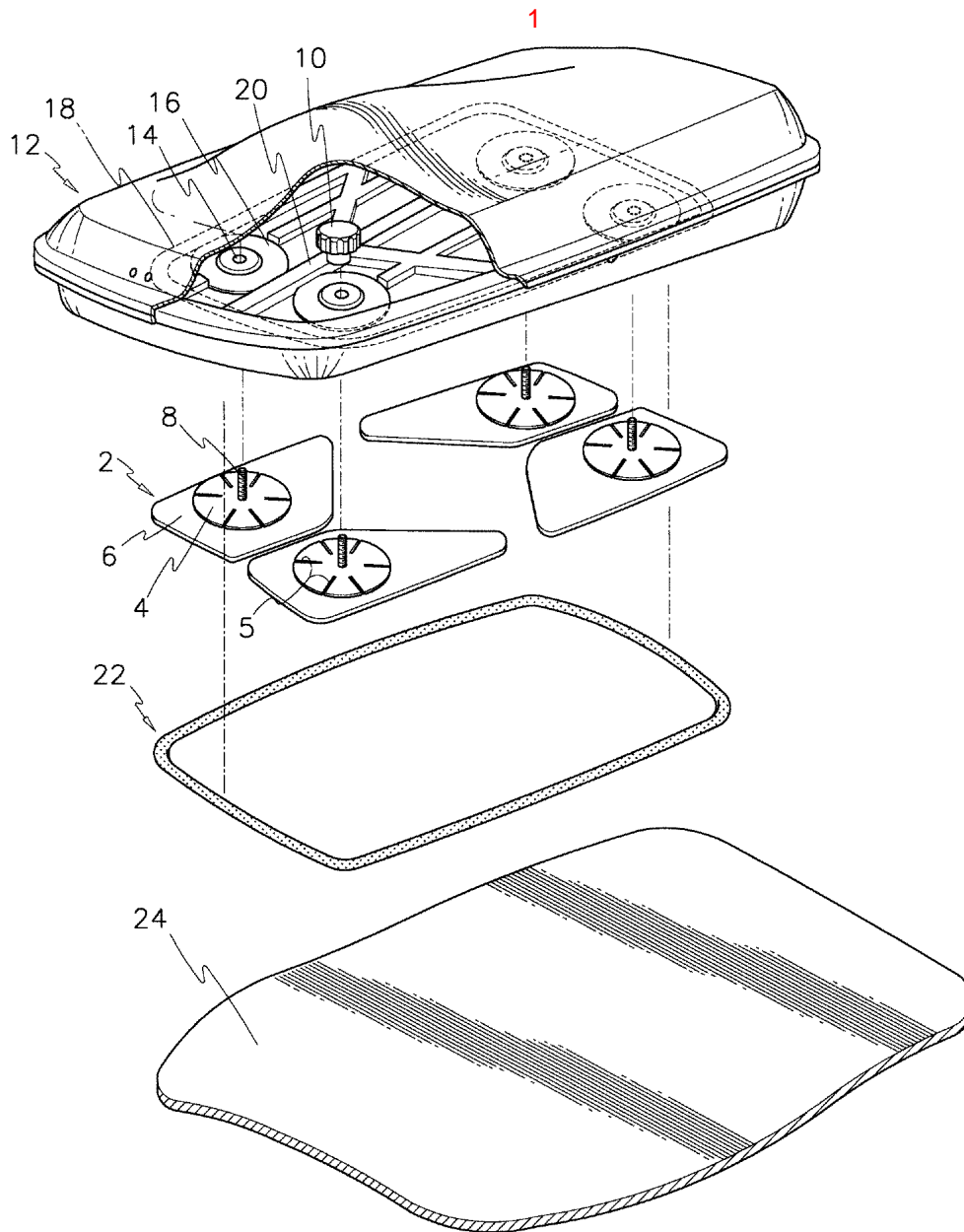

2

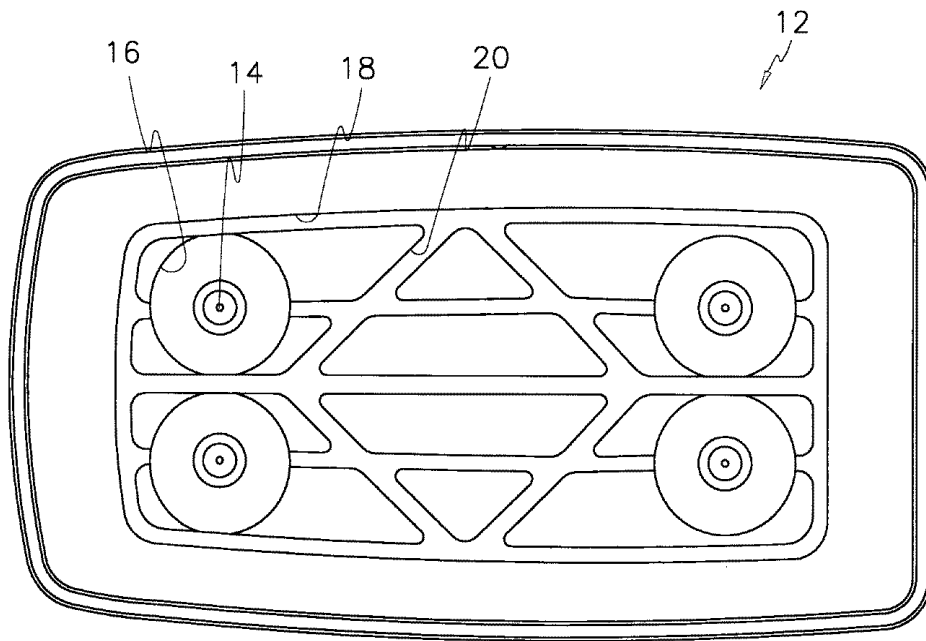

3

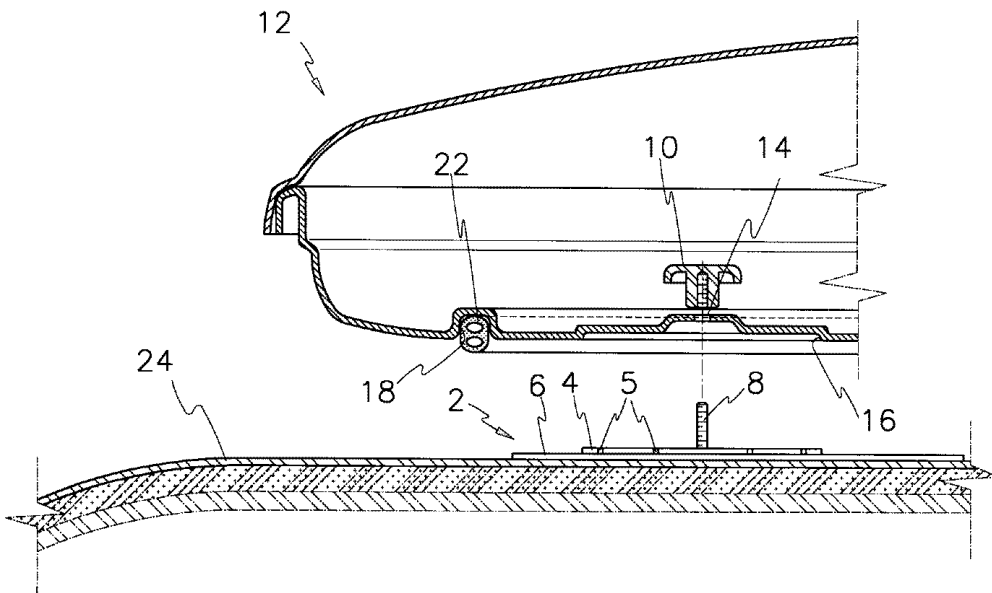

4

