



US 20040024471A1

(19) **United States**

(12) **Patent Application Publication**

Ferree

(10) **Pub. No.: US 2004/0024471 A1**

(43) **Pub. Date: Feb. 5, 2004**

(54) **BONE CELL COVERED ARTHROPLASTY DEVICES**

**Related U.S. Application Data**

(60) Provisional application No. 60/392,234, filed on Jun. 27, 2002.

(76) Inventor: **Bret A. Ferree**, Cincinnati, OH (US)

**Publication Classification**

Correspondence Address:  
**JERROLD J. LITZINGER**  
2134 MADISON ROAD  
CINCINNATI, OH 45208 (US)

(51) **Int. Cl.<sup>7</sup>** ..... **A61F 2/28; A61F 2/36; A61F 2/02**  
(52) **U.S. Cl.** ..... **623/23.63; 623/23.76; 623/23.15**

(57) **ABSTRACT**

Arthroplasty devices having improved bone in growth to provide a more secure connection within the body. Different embodiments disclosed include devices having threaded intramedullary components, devices configured to receive bone growth promoting substances, devices with resorbable components, and devices configured to reduce shear stress.

(21) Appl. No.: **10/607,664**

(22) Filed: **Jun. 27, 2003**

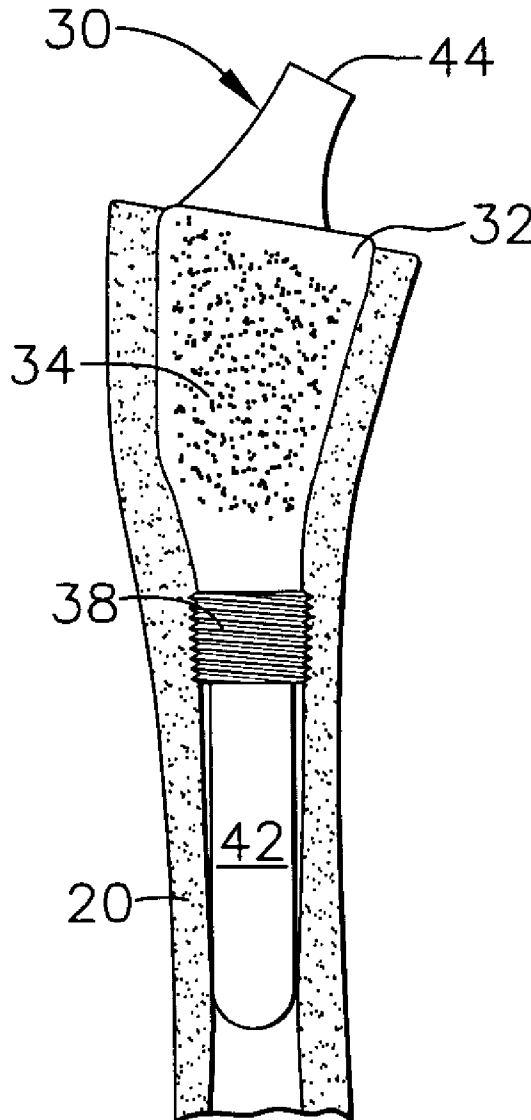

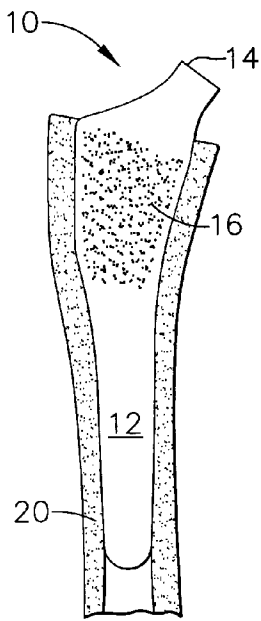

FIG. 1

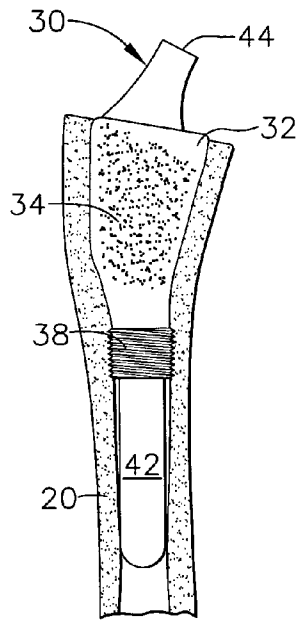

FIG. 2

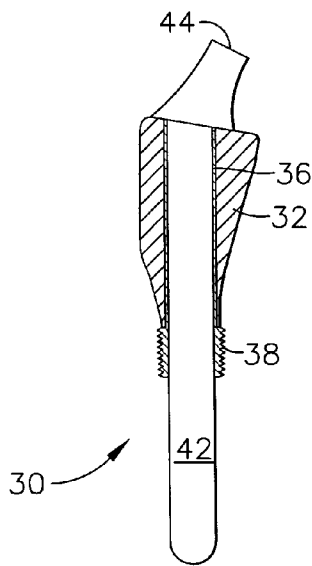

FIG. 3

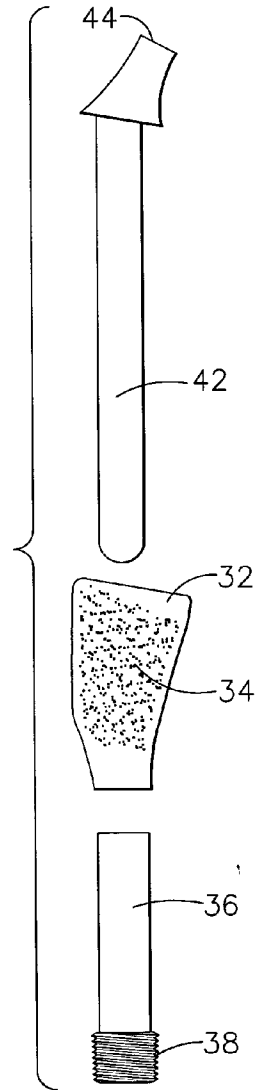

FIG. 4

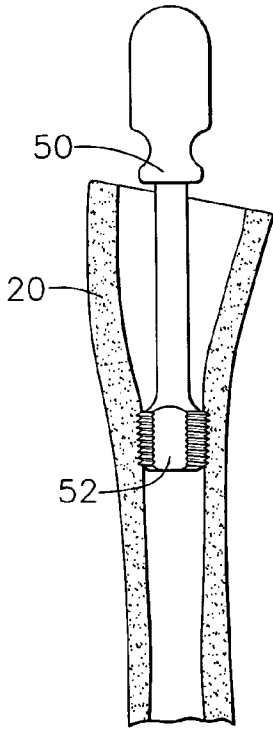

FIG. 5A

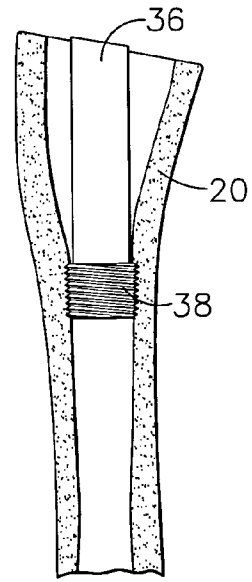

FIG. 5B

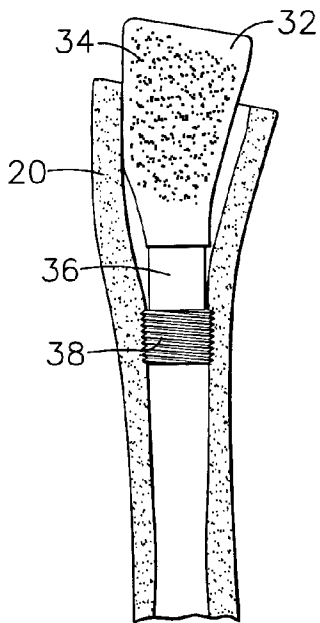

FIG. 5C

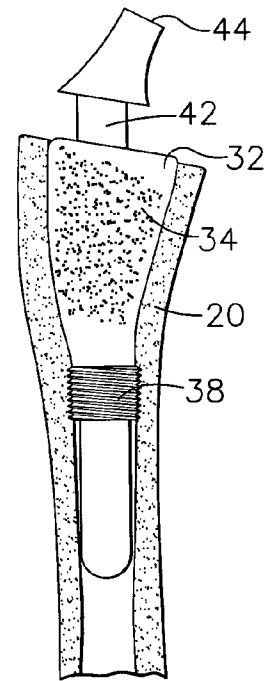

FIG. 5D

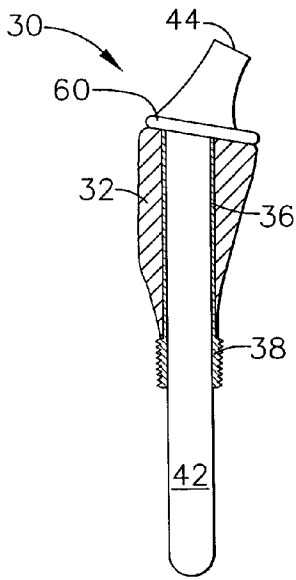

FIG. 6

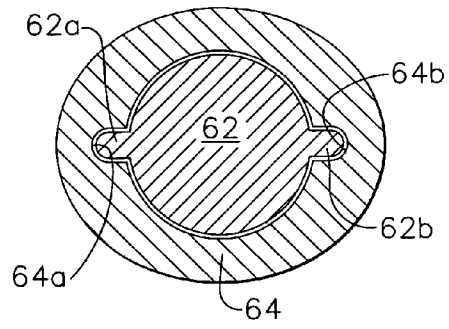

FIG. 7

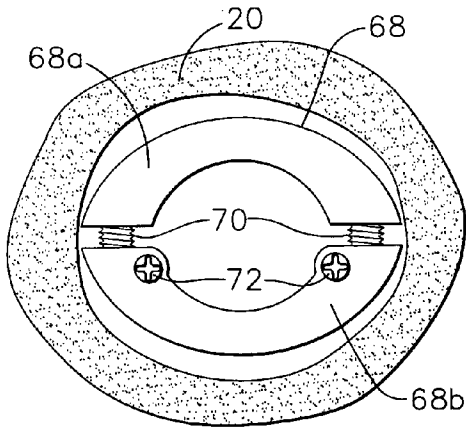

FIG. 8A

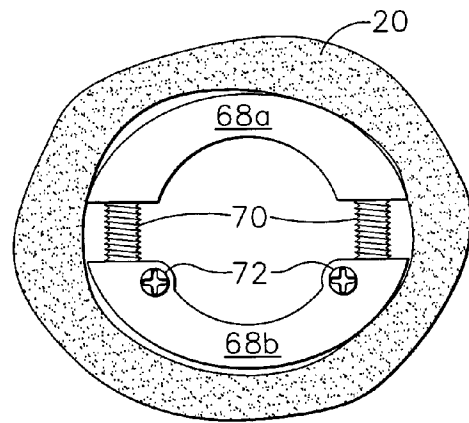

FIG. 8B

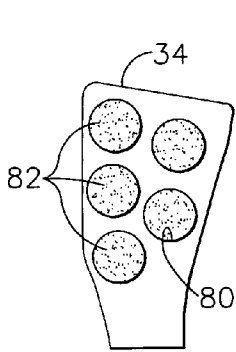

FIG. 9A

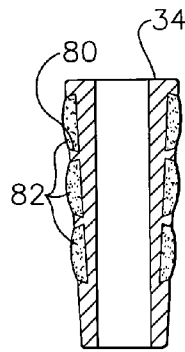

FIG. 9B

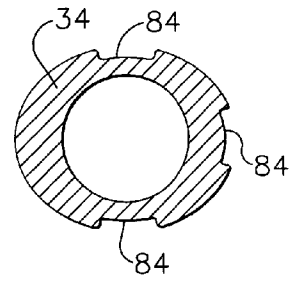

FIG. 9C

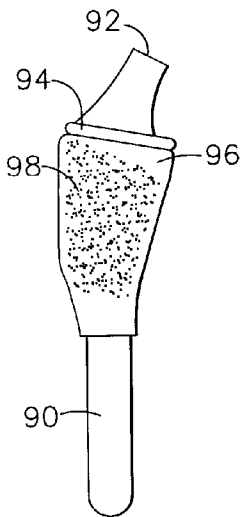

FIG. 10A

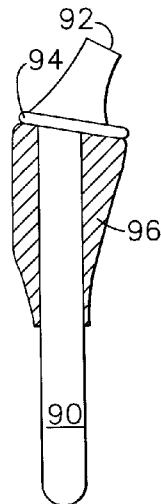

FIG. 10B

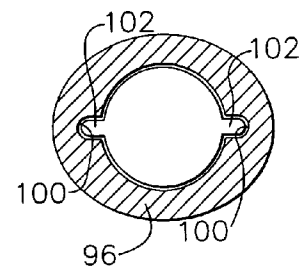

FIG. 10C

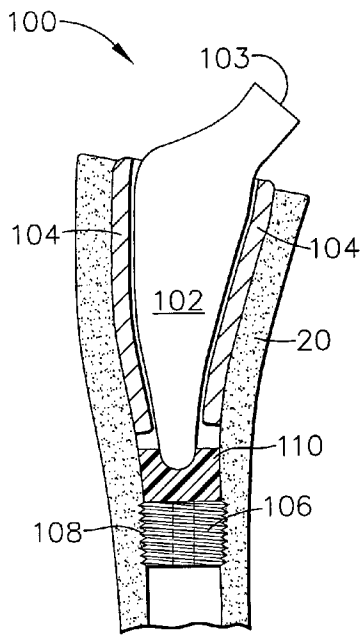

FIG. 11A

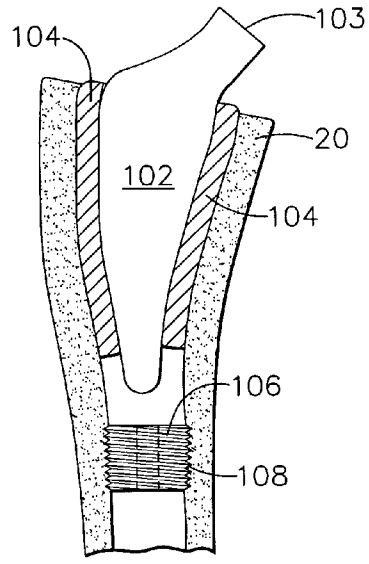

FIG. 11B

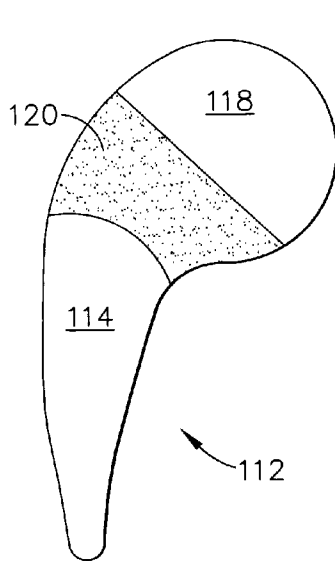

FIG. 11C

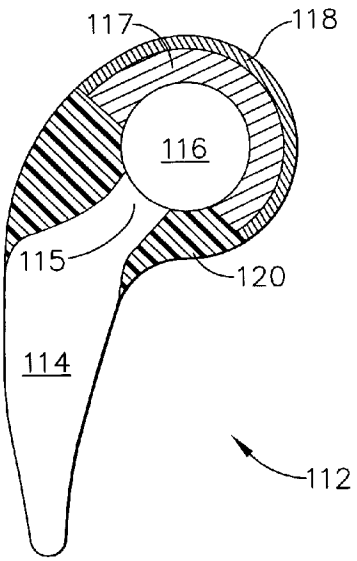

FIG. 11D

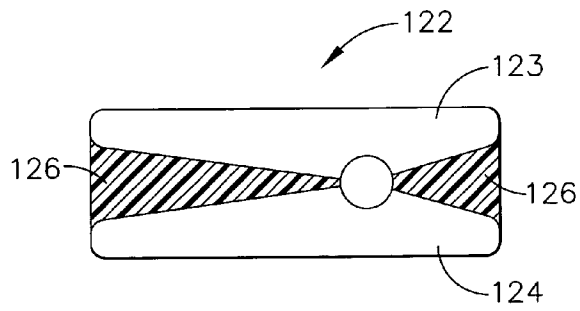

FIG. 11E

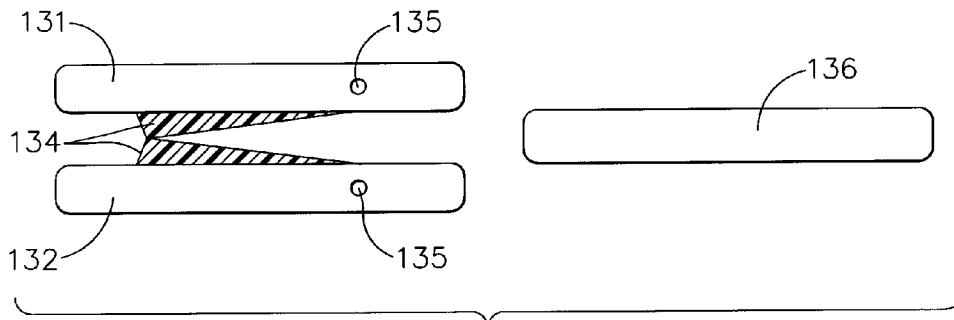

FIG. 12A

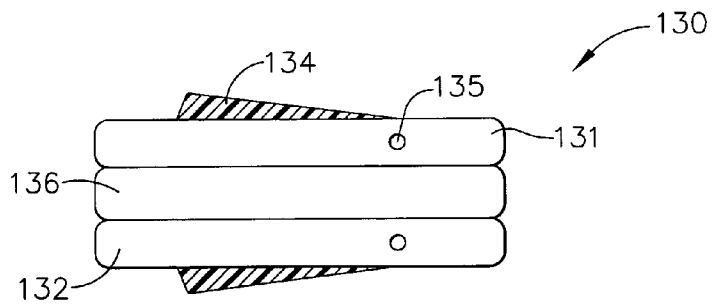

FIG. 12B

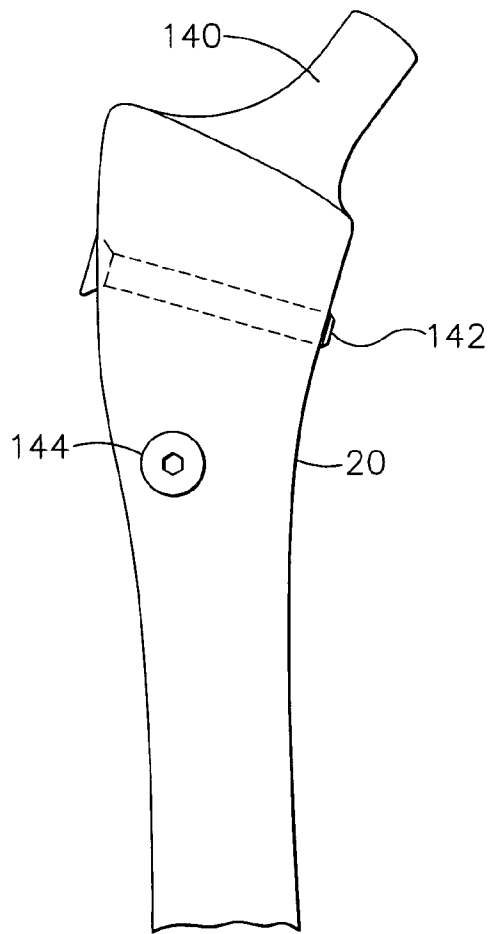

FIG. 13

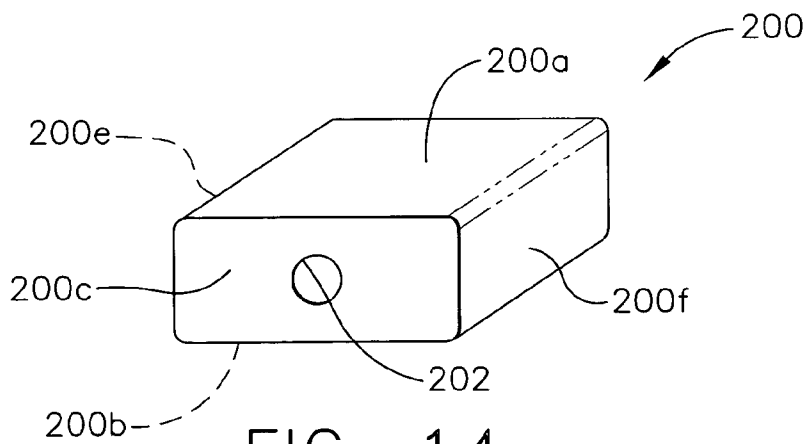

FIG. 14



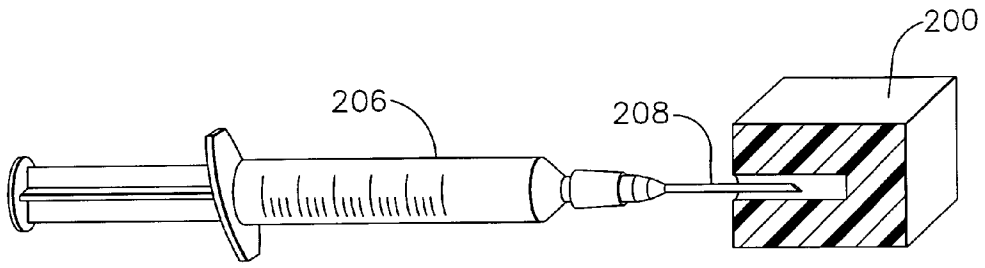

FIG. 15A

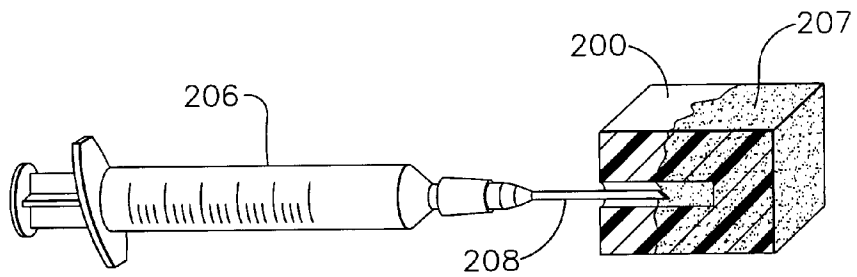

FIG. 15B

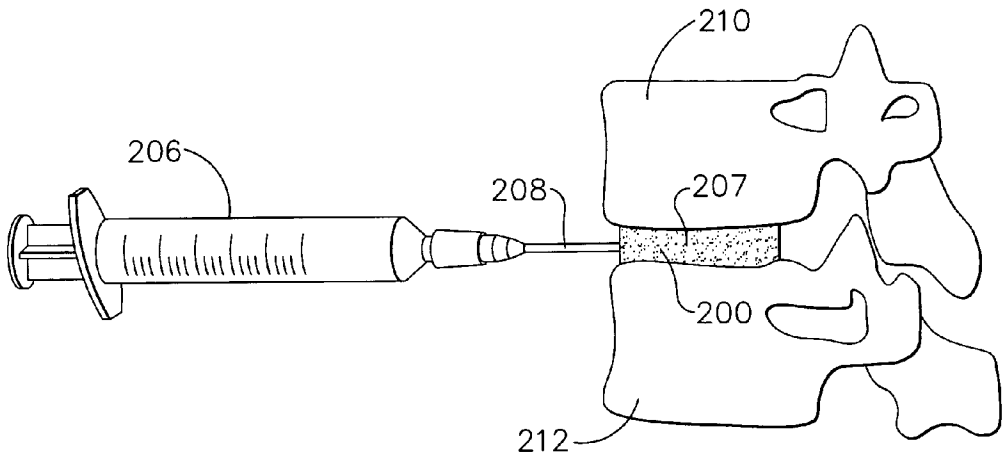

FIG. 16A

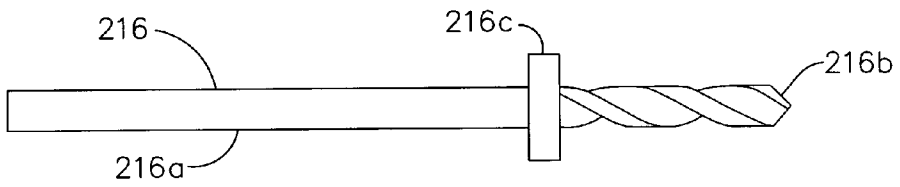

FIG. 16B

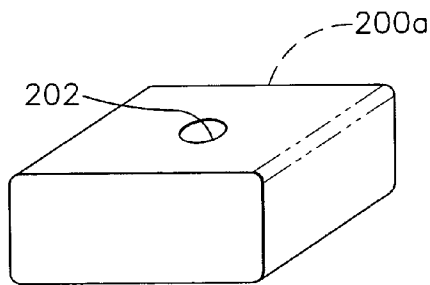

FIG. 17

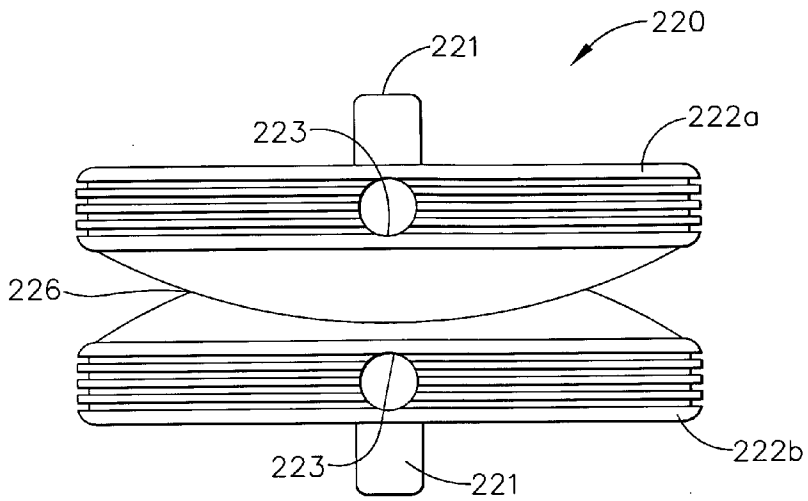

FIG. 18A

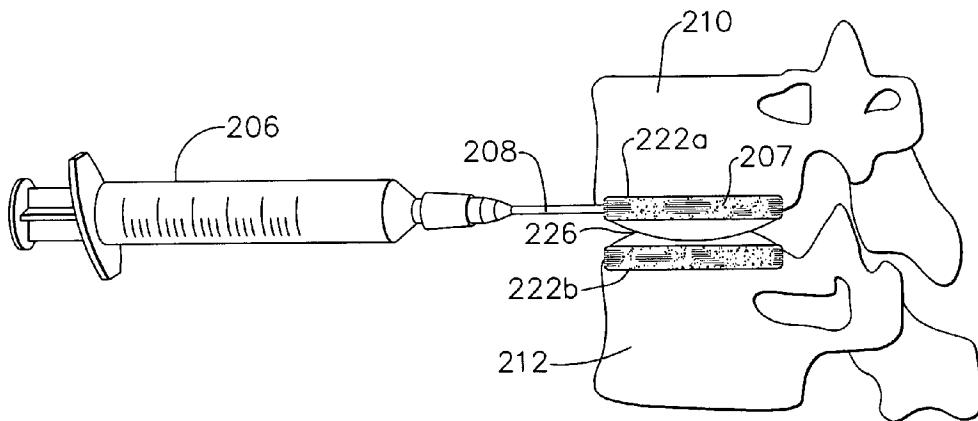

FIG. 18B

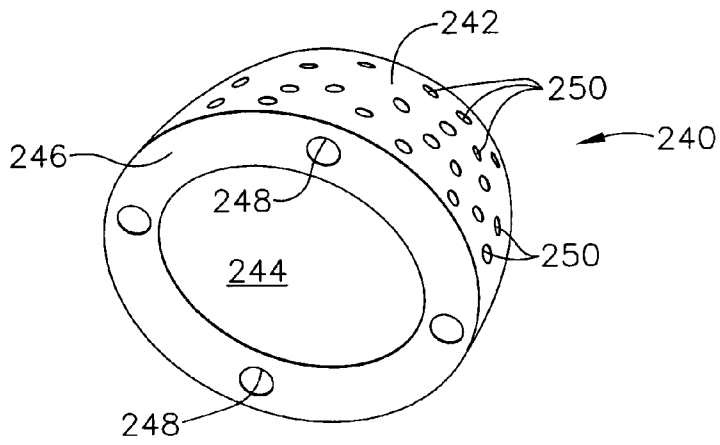

FIG. 19

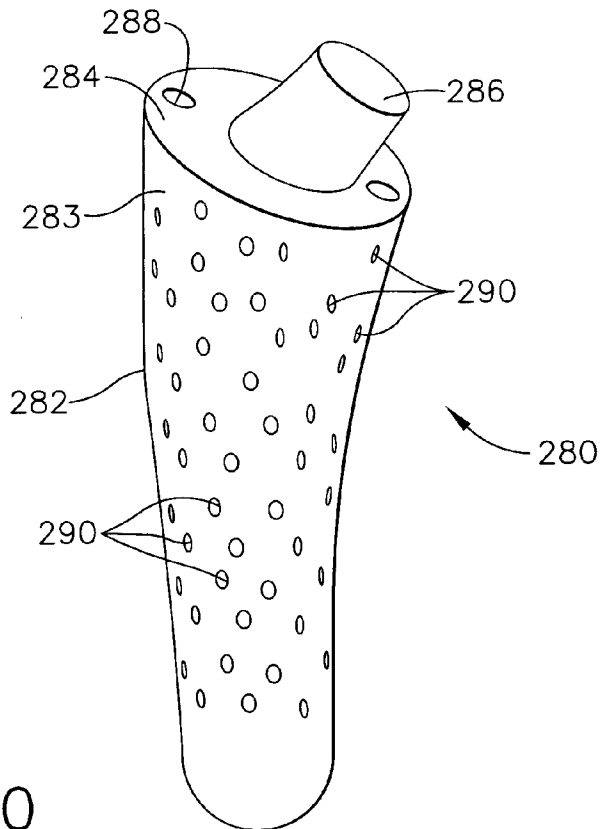

FIG. 20

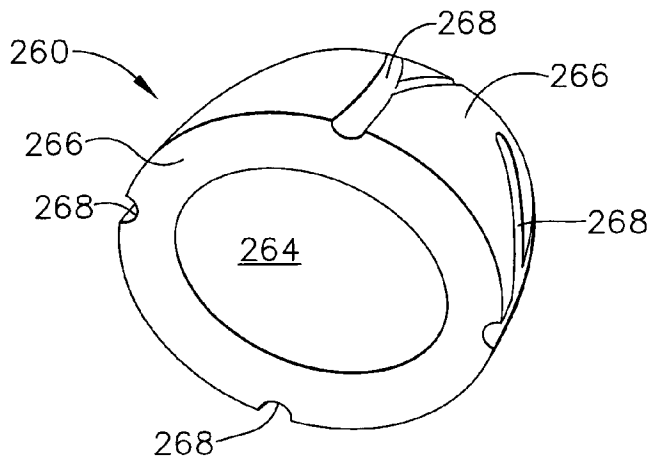

FIG. 21

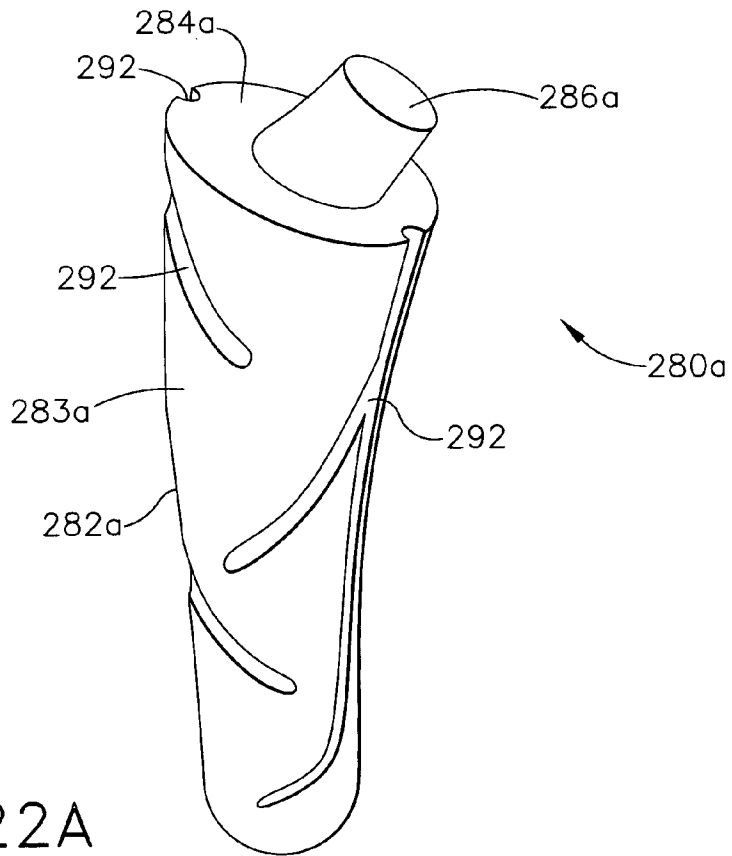

FIG. 22A

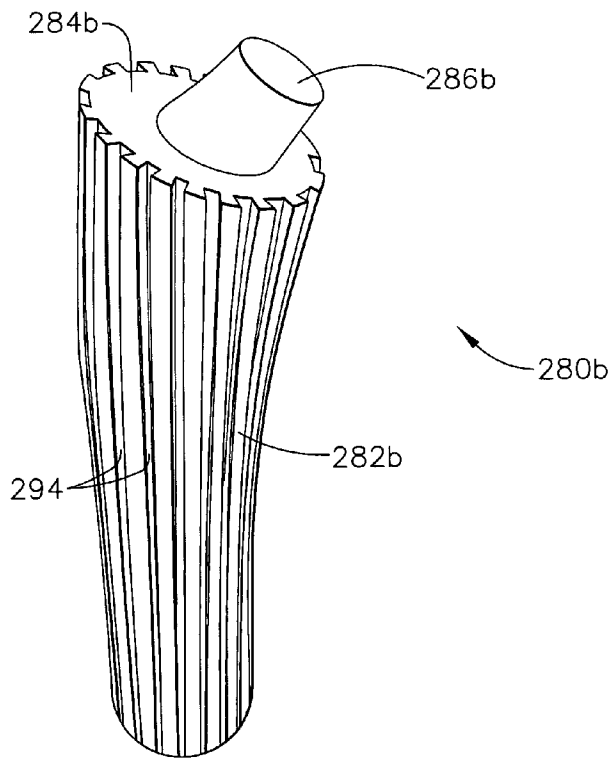

FIG. 22B

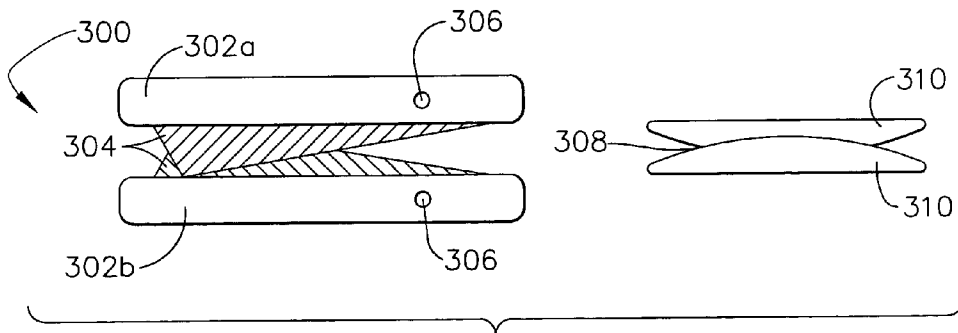

FIG. 23A

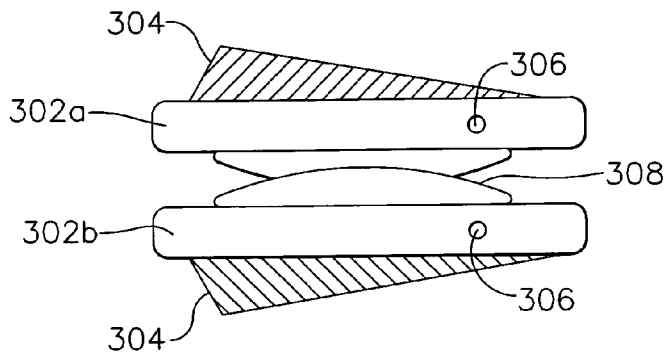

FIG. 23B

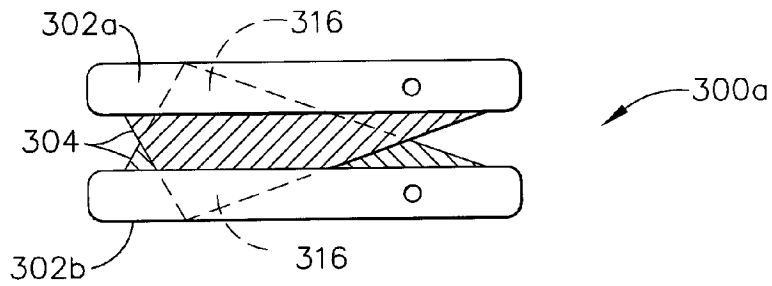

FIG. 23C

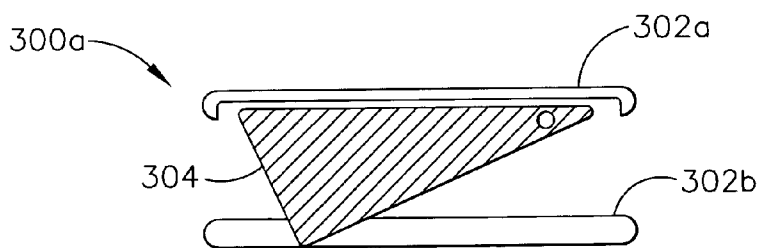

FIG. 23D

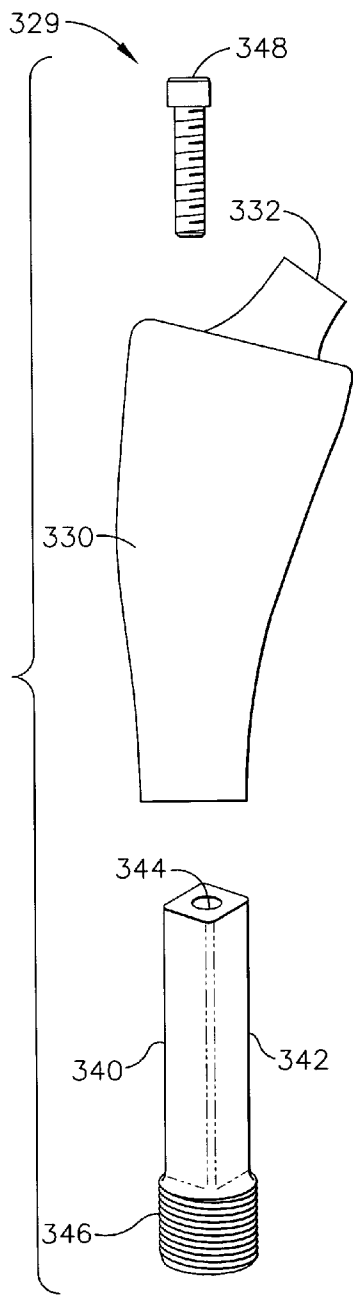

FIG. 24A

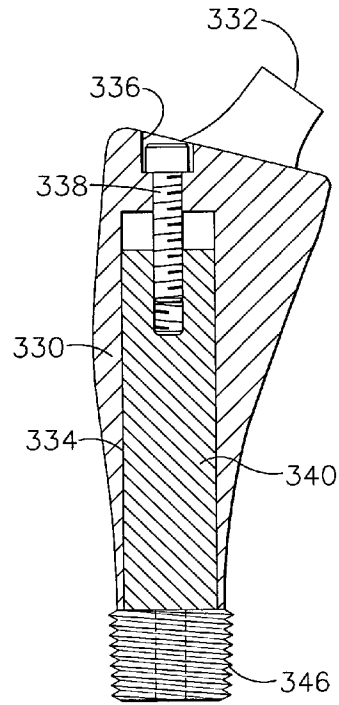

FIG. 24B



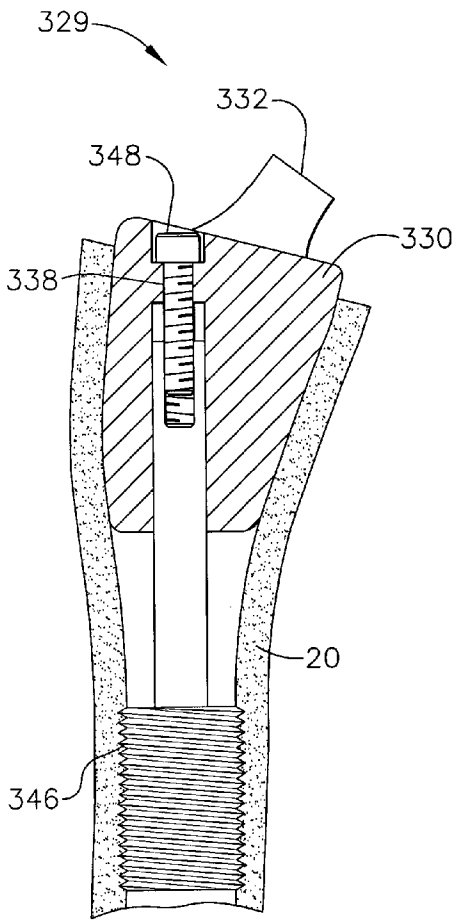

FIG. 24C

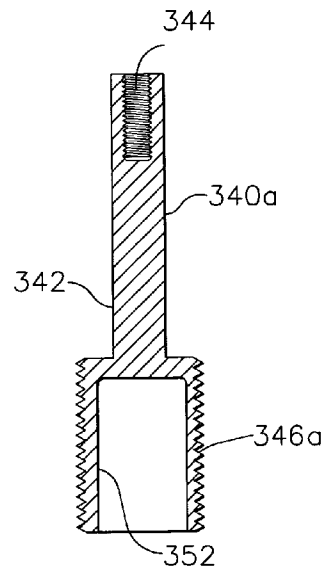

FIG. 24D

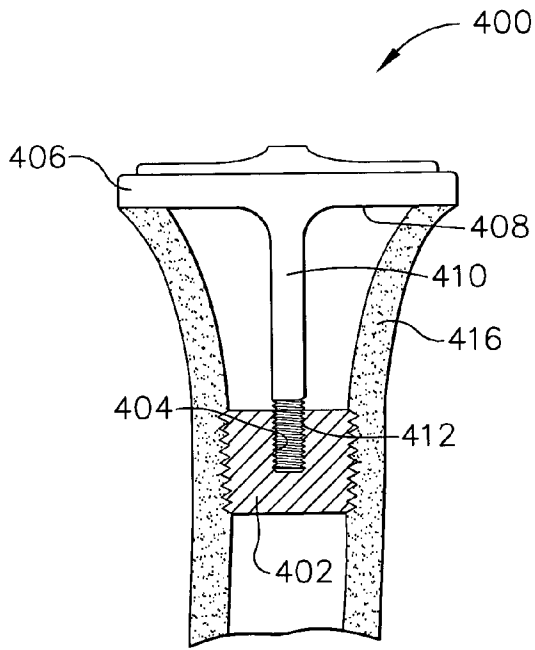

FIG. 25A

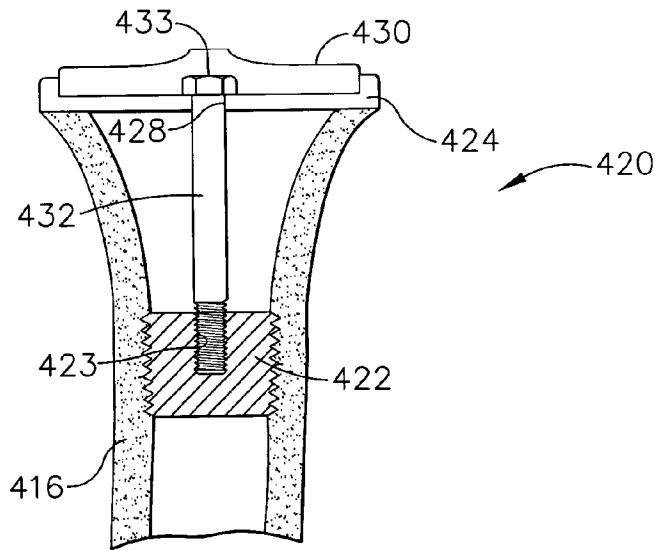

FIG. 25B

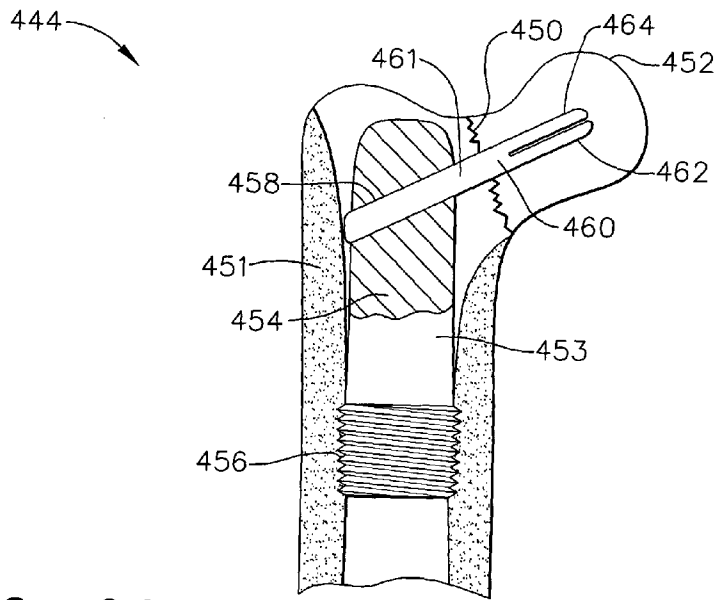

FIG. 26

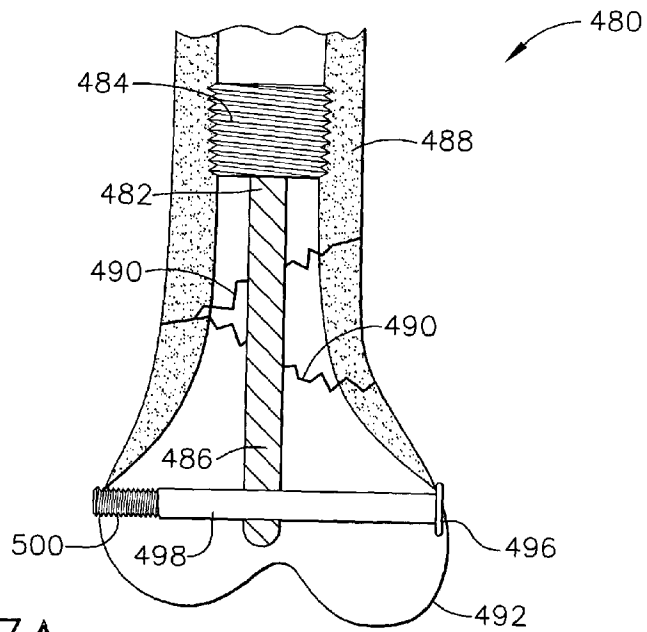

FIG. 27A

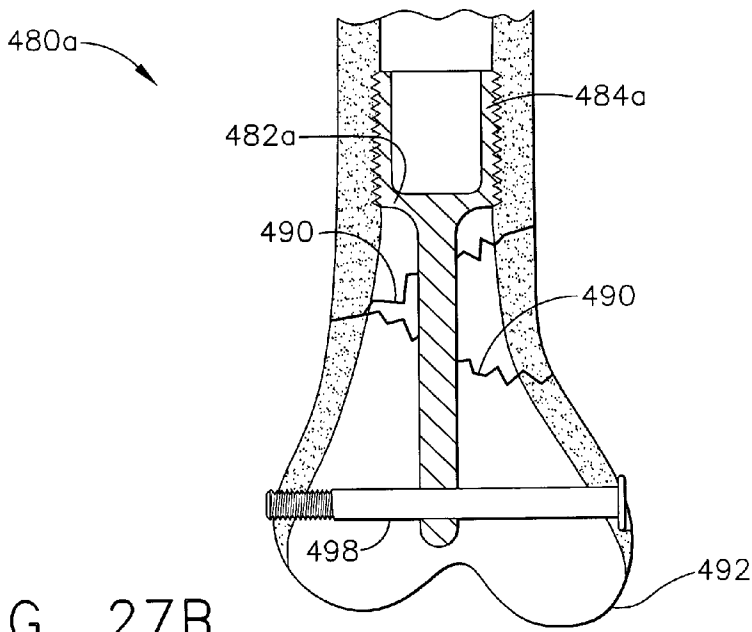

FIG. 27B

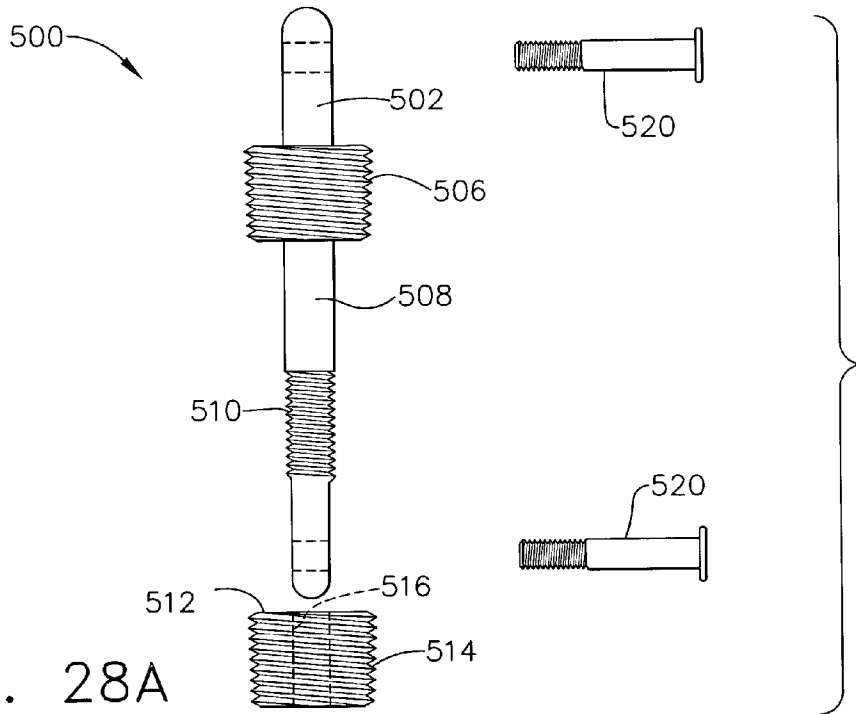

FIG. 28A

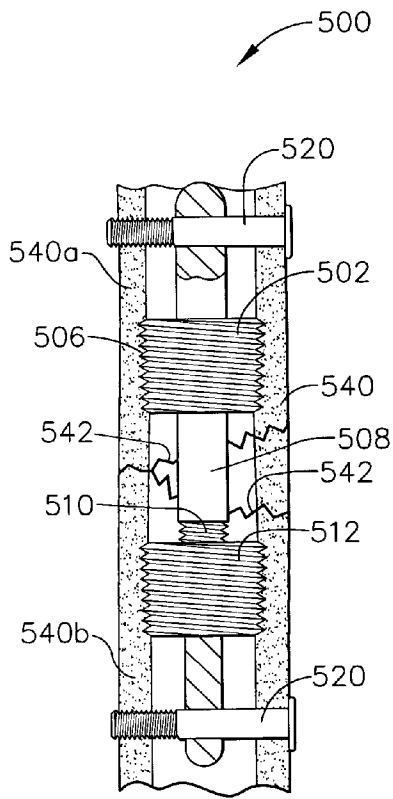

FIG. 28B

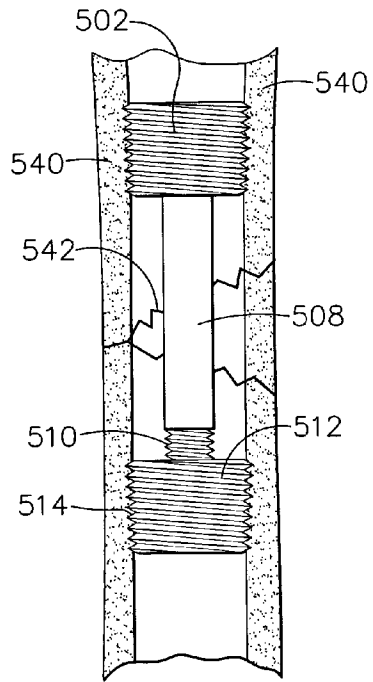

FIG. 28C

## BONE CELL COVERED ARTHROPLASTY DEVICES

### CROSS REFERENCE TO RELATED APPLICATIONS

[0001] This application claims benefit from U.S. Provisional Patent Application Serial No. 60/392,274, filed Jun. 27, 2002 which application is incorporated herein by reference.

### BACKGROUND OF THE INVENTION

[0002] 1. Field of the Invention

[0003] The present invention is directed in general to arthroplasty devices and, in particular, to arthroplasty devices which improve bone growth into said devices.

[0004] 2. Description of the Related Art

[0005] The use of arthroplasty devices to replace damaged or defective joints within the body is commonplace in the medical field. The prosthetic replacement of joints has evolved over the years from early relatively crude models to current prostheses which closely replicate functions and motions of a natural joint. Prosthetic arthroplasty devices have been used as replacements for the shoulder, hips, knee, ankle and intervertebral disc.

[0006] One problem encountered with prosthetic joints includes movement of the implant with respect to the patient's bones. This motion often compromises fixation. Another problem that occurs is an abnormal stress transfer from the implant to the bone.

[0007] The most common method of holding the implant in the bones is "press-fitting" the device into the intramedullary cavity of the bone. This often causes abnormal stress distribution, leading to premature failure.

[0008] These devices also rely on the ingrowth of the patient's bone to hold these devices in place. The difficulty of achieving true growth of a patient's bone into a metal prosthesis is a well known problem in the surgical field.

### SUMMARY OF THE INVENTION

[0009] It is, therefore, an object of the present invention to provide an arthroplasty device which has improved bone ingrowth capabilities.

[0010] It is a further object of the present invention to provide an arthroplasty device configured to reduce shear stress.

[0011] It is a still further object of the present invention to provide an arthroplasty device having a resorbable component which restricts motion in a joint for a period of time to allow for improved bone ingrowth.

[0012] It is a still further object of the present invention to provide an arthroplasty device configured to receive bone growth promoting substances.

[0013] These and other objects and advantages of the present invention will be readily apparent in the description the follows.

### BRIEF DESCRIPTION OF THE DRAWINGS

[0014] FIG. 1 is a lateral view, partly in cross section, of a femur and a prior art impacted femoral component of a hip replacement;

[0015] FIG. 2 is a lateral view, partly in cross section, of a femur and an embodiment of the present invention showing a femoral hip replacement device having a threaded component;

[0016] FIG. 3 is a cross-sectional view of the embodiment of the present invention shown in FIG. 2;

[0017] FIG. 4 is an exploded view of the device of FIG. 2;

[0018] FIGS. 5A-D, taken together, show the sequence of installation of the device of FIG. 2;

[0019] FIG. 6 is a lateral view, partly in cross section, of the device of FIG. 2 which includes a collared rod component;

[0020] FIG. 7 is a cross-sectional view of the device of FIG. 2 which includes an anti-rotation feature;

[0021] FIG. 8A is a cross-sectional view of the femur and another embodiment of the device of the present invention having an expandable component shown in the contracted position;

[0022] FIG. 8B is a cross-sectional view of the device of FIG. 8A showing the expandable component in the extended position;

[0023] FIG. 9A is a lateral view of another embodiment of the present invention;

[0024] FIG. 9B is a cross-sectional view of the device of FIG. 9A;

[0025] FIG. 9C is a cross-sectional view of another version of the device of FIG. 9A;

[0026] FIG. 10A is a lateral view of another embodiment of the present invention;

[0027] FIG. 10B is a cross-sectional view of the device of FIG. 10A;

[0028] FIG. 10C is a different cross-sectional view of the device of FIG. 10A;

[0029] FIG. 11A is a lateral view, partly in cross section, of another embodiment of the present invention;

[0030] FIG. 11B is a lateral view, partly in cross section, of the device of FIG. 11A after a period of time;

[0031] FIG. 11C is a lateral view of another embodiment of the present invention;

[0032] FIG. 11D is a cross-sectional view of the device of FIG. 11C;

[0033] FIG. 11E is a lateral view of another embodiment of the present invention;

[0034] FIG. 12A is a lateral view of an alternative device according to the present invention for use in prosthetic disc replacement shown in the unassembled position;

[0035] FIG. 12B is a lateral view of the device of FIG. 12A in the assembled position;

[0036] FIG. 13 is a lateral view of a femoral component according to the present invention;

[0037] FIG. 14 is a perspective view of another embodiment of the present invention;

[0038] FIG. 15A is a perspective view of the device of FIG. 14 with a portion of the device removed and a syringe shown for injecting a bone growth promoting substance into the device;

[0039] FIG. 15B is a perspective view of FIG. 15A showing the device of FIG. 14 partially filled;

[0040] FIG. 16A is a lateral view of a section of the spine showing the device of FIG. 14 installed in position between the vertebrae;

[0041] FIG. 16B is a lateral view of a drill bit which may be used to create a hole in the device of FIG. 14;

[0042] FIG. 17 is a perspective view of an alternative embodiment of the device of FIG. 14;

[0043] FIG. 18A is an end view of an alternative artificial disc replacement device for use in the present invention;

[0044] FIG. 18B is a sectional view of the device of FIG. 18A positioned between vertebrae of the spine;

[0045] FIG. 19 is a perspective view of an acetabular component for use in an embodiment of the present invention;

[0046] FIG. 20 is a perspective view of a femoral component for use in an embodiment of the present invention;

[0047] FIG. 21 is a perspective view of an alternative acetabular component similar to the device of FIG. 19;

[0048] FIG. 22A is a perspective view of an alternative femoral component similar to the device of FIG. 20;

[0049] FIG. 22B is a perspective view of another alternative femoral component similar to the devices of FIG. 20 and FIG. 22A;

[0050] FIG. 23A is a lateral view of an alternative embodiment of the device of FIG. 12A;

[0051] FIG. 23B is a lateral view of the device of FIG. 23A shown in the deployed position;

[0052] FIG. 23C is a lateral view of an alternative embodiment of the device shown in FIG. 23A;

[0053] FIG. 23D is a sectional view of the device of FIG. 23C;

[0054] FIG. 24A is an exploded view of an alternative embodiment of a device according to the present invention;

[0055] FIG. 24B is a cross-sectional view of the device of FIG. 24A in the assembled position;

[0056] FIG. 24C is a cross-sectional view of the device of FIG. 24A installed in the femur;

[0057] FIG. 24D is a cross-sectional view of an alternative embodiment the threaded component shown in FIG. 24A;

[0058] FIG. 25A is a cross-sectional view of a device according to the present invention installed in the tibia;

[0059] FIG. 25B is a cross-sectional view of an alternative embodiment of the device of FIG. 25A;

[0060] FIG. 26 is a cross-sectional view of a device according to the present invention installed in the proximal femur;

[0061] FIG. 27A is a cross-sectional view of a device according to the present invention installed in the distal femur;

[0062] FIG. 27B is a cross-sectional view of an alternative embodiment of the device of FIG. 27A installed in the distal femur;

[0063] FIG. 28A is an exploded view of a device according to the present invention for use in a long bone;

[0064] FIG. 28B is a cross-sectional view of the device of FIG. 28A invention installed in a long bone;

[0065] and FIG. 28C is a cross-sectional view of an alternative embodiment of the device of FIG. 28A.

#### DETAILED DESCRIPTION OF THE EMBODIMENTS

[0066] FIG. 1 represents a typical prior art impacted femoral component of a hip replacement commonly used in the surgical field today. Referring now to FIG. 1, there is shown a femoral component 10 having an elongated tapered portion 12, an extended stem portion 14 for connecting component 10 to the prosthetic femoral head, and a textured surface area 16. In use, tapered portion 12 is driven into a femur 20 which has been prepared to receive component 10. Surface area 16 of component 10 is configured to encourage bone ingrowth to assist in the permanent attachment of component 10 within femur 20. Surface area 16 may contain small beads, fibrillar wires or other structures known in the art to promote bone ingrowth. This type of arthroplasty device relies on impaction of the device into patients' bones for stability.

[0067] The difficulty of achieving true growth of a patient's bone into metal prostheses is well known in the medical field. FIGS. 2-4 show a device according to the present invention which assists in overcoming this problem. Femoral hip replacement device, generally designated as 30, includes an upper outer sleeve 32 which contains a textured surface area 34, a tubular inner component 36 having a threaded lower portion 38, and an elongated rod component 42 having an outwardly extending stem 44. In operation, threaded portion 38 of component 36 engages an internally threaded area which has been previously incorporated into femur 20. Alternatively, portion 38 may contain self tapping threads for attachment within femur 20. Sleeve 32 is then installed on the tubular portion of component 36 such that it is held against threaded portion 38 and the inner walls of femur 20. Elongated rod component 42 is then inserted through tubular component 36 such that it is tightly held in place by sleeve 32 and femur 20, as can be best seen in FIG. 2.

[0068] Although device 30 contains surface area 34 to assist bone ingrowth, threaded section 38 helps to stabilize device 30, as threaded components are less likely to allow motion between the device and bone. Bone ingrowth, which is dependent upon the surface features of the device and motion between the device and the bone, is thus facilitated by decreasing motion between the arthroplasty device and a patient's bone.

[0069] The process for installing device 30 is shown in FIGS. 5A-D. Referring now to FIG. 5A, a tap 50 having a thread cutting end 52 is used to chase threads within femur

**20** in the area in which threaded portion **38** of component **36** is to be affixed within femur **20**. Alternatively, portion **38** may be manufactured as a self-tapping device. After this has been performed, portion **38** is brought into threaded engagement with femur **20**, with tubular portion **36** positioned above the threaded connection (FIG. sleeve **5B**). Next, outer sleeve **32** is forced over tubular portion **36** until the edge of sleeve **32** contacts threaded portion **38** (FIG. **5C**). Finally, elongated rod component **42** is inserted through tubular portion **36** captured within sleeve **32** such that outwardly extending stem **44** is properly positioned for attachment within the prosthetic femoral head. This construction decreases the possibility of motion between device **30** and femur **20**, potentially enhancing bone ingrowth.

[0070] FIG. 6 represents another embodiment of device **30** which a collar **60** positioned on rod component **42** between stem **44** and sleeve **32** to aid in the positioning of device **30** within femur **20**. In this embodiment, rod component **42** is inserted through tubular portion **36** within sleeve **32** until collar **60** contacts sleeve **32**. In this manner, forces within rod component **42** are transferred to sleeve **32** having textured surface **34** for bone ingrowth, adding additional stability to device **30**.

[0071] FIG. 7 is a sectional view of an alternative embodiment of device **30** which adds an anti-rotation feature for additional stability. Referring now to FIG. 7, rod component **62** contains outwardly extending edges **62a**, **62b**. Tubular component **64** contains a pair of channels **64a**, **64b** within its inner walls corresponding to edges **62a**, **62b**. In this manner, rod component **62** cannot rotate within tubular component **64**, adding additional stability to the arthroplasty device, which potentially promotes bone ingrowth. Rod component **62** may also contain a cruciform shape, with tubular component **64** having a corresponding shape.

[0072] Square threads, buttress threads, or reverse buttress threads may be used in the embodiments requiring threaded devices, as these decrease hoop stress on the bone. Hoop stress can lead to fracture of the bone. Taper threads may also be used. In addition, the threads can be either left or right handed.

[0073] FIGS. 8A-B represent another alternative embodiment for an arthroplasty device according to the present invention. In this embodiment, an adjustable component **68** having a first section **68a** and a second section **68b** which are movable relative to each other by a pair of adjusting screws **70** is inserted into femur **20** in order to fit a patient's bone anatomy better. Screws **70** are adjustable to shift component **68** between a contracted position (FIG. **8A**) and an expanded position (FIG. **8B**). Screws **70** are adjusted by a corresponding pair of screws **72** which, when turned, control the adjusting motion provided by screws **70**. Alternatively, a wrench may be used to turn a screw, or gear, which cooperates with a toothed component to force sections **68a** and **68b** apart.

[0074] Component **68** is placed into the intramedullary canal of a bone and expanded. The tighter fit provided by component **68** decreases motion between the prosthesis and the patient's bone. Adjustable component **68** also allows for compaction of the cancellous bone with the cortical bone into which the prosthesis device is inserted. Cancellous bone is rich in cells that promote bone ingrowth. Prior art impacted devices are generally inserted into the cortical

bone after the removal of most of the cancellous bone. Thus, expanding components such as component **68** will aid in the immobilization of the prosthesis and preserve the healing characteristics of cancellous bone. While the device shown in FIGS. 8A-B show expansion of one component in one direction, multiple components may be used that expand in multiple directions. A torque wrench may be used to control the force and help prevent fracture of the bone into which the device is to be inserted. In addition, shape memory materials may be used to change the shape of components within the device. For example, a sleeve made of nitinol could be inserted in its contracted shape and then open to the expanded shape after insertion into the base.

[0075] Alternative expansion mechanisms could be used for component **68**. For example, a scissor jack-like mechanism or inclined planes could be used to move the sections to its expanded position. In addition, multiple sections can be used that expand in multiple directions.

[0076] In another embodiment, a rod component similar to that shown in FIGS. 2-6 is inserted between sections of component **68** in its expanded expansion. The implanted rod may be held in position within component **68** by adding a taper to the interior surfaces of sections **68a** and **68b**.

[0077] Upper outer sleeve **32** which contains textured surface area **34** in FIG. 2 can be adapted to further enhance bone ingrowth in devices according to the present invention. FIGS. 9A-C demonstrate several alternative embodiments which may be used to further promote this growth. Referring now to FIG. 9A, upper outer sleeve **34** contains a plurality of wells **80** along its outer surface which replaces the textured surface. Wells **80** are filled with collagen sponges **82** which have been soaked with Base Morphogenetic Protein (BMP). Sponges **82** are inserted into wells **80** prior to insertion of device **30** into femur **20**. In FIG. 9C, sleeve **34** contains a plurality of channels **84** which extend along the length of sleeve **34**. In this embodiment, BMP could be injected into channels **84** after insertion of device **30**, or BMP soaked collagen sponges **82** may be forced into channels **84**.

[0078] Another alternative embodiment of an arthroplasty device according to the present invention is shown in FIGS. 10A-C. A femoral rod component **90** having an outwardly extending stem **92** and a collar stop **94** is installed through a sleeve **96** having a textured area **98** for promoting bone ingrowth. The interior of sleeve **96** contains of pair of grooves **100** which correspond to a pair of wings **102** extending from the outer surface of component **90** such that the interaction of wings **102** and grooves **100** allow small amounts of motion between rod component **90** and sleeve **96** to decrease the shear stress on textured area **98** where bone ingrowth occurs. Shear stress can cause motion between the device and the patient's bone, decreasing the chance of bone ingrowth. Devices using anti-rotation features, such as shown in FIG. 10C and FIG. 7, will have rods with varying degrees of version, including antiversión and retroversion.

[0079] FIGS. 11A-E show an alternative embodiment of the device according to the present invention which uses resorbable components to temporarily decrease or remove the stress on the bone ingrowth surfaces of the device. Referring now to FIG. 11A, an arthroplasty device **100** similar to the device of FIGS. 10A-C is shown, having a femoral rod component **102** with a outwardly extending



stem **103**, a positioning sleeve **104** having a textured area (not shown) for promoting bone growth, and a solid disc **106** having an threaded outer surface **108**. Disc **106** is initially positioned within a femur **20**. Disc **106** has been installed into position within femur **20**, after its interior has been threaded in the appropriate area by using a tool similar to that shown in FIG. 5A. Alternatively, outer surface **108** may contain self-tapping threads. Resorbable material **110** is threaded into femur **20**, contacting disc **106**, and then rod component **102** is introduced into sleeve **104**. Note that component **102** is supported by resorbable material **110** and not sleeve **104**. Preferably, device **100** contains the anti-rotation features shown in FIG. 10C. Additionally, anti-rotation features can also be added between disc **106**, resorbable material **110** and the end of rod component **102** for additional stability. Suitable resorbable materials include a high molecular weight poly-L-lactic acid (PLLA) polymers, calcium hydroxyapatite, tricalcium phosphate. Other potentially useful resorbable materials include polydioxanone (PDS), oxidized regenerated cellulose and various forms of collagen.

[0080] In this relationship, resorbable material **110** temporarily decreases or removes the stress on the bone ingrowth surfaces of sleeve **104**. The forces on device **100** are transferred from resorbable material **110** to the ingrowth surfaces of sleeve **104** as resorbable material **110** disappears. Disc **106** may also contain a through hole **111** to aid in the drainage of resorbable material **110**. This resorption process generally takes months. Bone will grow into the ingrowth area of sleeve **104** while device **100** is supported by resorbable material **108**. Eventual transfer of the forces to the ingrowth area of device **100** is important to prevent bone resorption that occurs with stress shielding. Resorbable material **110** may also temporarily eliminate movement through device **100**. Eliminating movement across device **100** decreases forces on the bone ingrowth surfaces. Motion through device **100** is permitted once resorbable materials **110** has dissolved, as rod component **102** now contacts sleeve **104**, as can be seen in FIG. 11B.

[0081] A prosthetic hip device according to the present invention is shown in FIGS. 11C-D. Hip device **112** includes a femoral rod component **114** having an outwardly extending stem **115**, a head **116** mounted on stem **115**, an inner acetabular component **117**, and an outer acetabular component **118**. A resorbable component **120** is located between component **118** and rod component **114** to restrict motion between the acetabular and femoral components of device **112** until resorbable component **120** disappears, allowing time for bone ingrowth to firmly take hold.

[0082] FIG. 11E shows prosthetic disc replacement device **122** according to the present invention. Device **122** includes an upper plate **123** and a lower plate **124** connected by a pivot **125**. Resorbable material **126** is placed between plates **123** and **124** before insertion of device **122** into a position between vertebrae of the spine.

[0083] FIGS. 12A-B show an alternative embodiment of a prosthetic disc replacement device **130**. Device **130** contains an upper plate **131** and a lower plate **132**. Each plate contains a keel-like ingrowth extension component **134** attached for rotation through plates **131**, **132** at a pivot **135**. An activation device **136** consisting of a flat plate is also shown. To install device **130**, the device is placed between vertebrae in the

spine of a patient. Activation device **136** is pushed between plates **131** and **132** to force extensions **134** away from plates **131**, **132** to affix device **130** in its proper location between the vertebrae. Extensions **134** are exposed to the cancellous bone of the vertebrae, immobilize device **130** and help prevent its extrusion.

[0084] FIG. 13 shows another embodiment of a method for restricting motion of the prosthesis relative to the bone when using an arthroplasty device. Referring now to FIG. 13, there is shown a femoral component **140** positioned within femur **20**. Component **140** is held firmly in place by a first screw **142** which is affixed crosswise through component **140** and femur **20**. A second screw **144** is affixed through component **140** and femur **20** in a direction oriented approximately 90° to first screw **142**. A guide is preferably removably attached to femur **20** or component **140** to help direct a drill bit through femur **20** and to thread screws **142** and **144** through the structure. Use of screws **142** and **144** assist in minimizing motion of component **140** with respect to femur **20**, allowing bone ingrowth between component **140** and femur **20**.

[0085] FIG. 14 shows a device which promotes bone ingrowth in a spinal fusion procedure. Implant **200** consists of a box-like structure having top and bottom surfaces **200a**, **200b**, front and rear surfaces **200c**, **200d**, and side surfaces **200e**, **200f**. In this embodiment, surfaces **200a** and **200b** are essentially parallel, **200c** and **200d** are essentially parallel, and **200e** and **200f** are essentially parallel; however, implant **200** can consist of any shape which will fit between adjacent vertebrae. Surface **200c** contains an aperture **202** which allows access to the interior of implant **200**. Aperture **202** allows for the injection of a bone growth promoting substance into implant **200**. Possible substances include Platelet Rich Plasma (PRP), bone morphogenetic protein (BMP), or concentrated leukocytes. Other substances which are available are discussed in my co-pending patent application Ser. No. 09/897,000, which application is incorporated by reference herein. Although implant **200** is preferably manufactured from bone, it could also be constructed from other compatible materials such as metal or polymers. Alternatively, the metal or polymer devices could be filled with bone.

[0086] FIGS. 15A-B show how implant **200** can be filled with an appropriate bone growth promoting substance. A syringe **206** filled with a suitable substance **207** is positioned with its needle **208** inserted through aperture **202**. As syringe **206** is operated, substance **207** fills implant **200** with the bone growth promoting fluid, as can be seen clearly in FIG. 15B. FIG. 16A shows implant **200** in position between adjacent vertebrae **210**, **212** while syringe **206** injects growth substance **207** into the implant.

[0087] A drill bit **216** is shown in FIG. 16B which may be used to create aperture **202** in implant **200**. Bit **216** contains a smooth cylindrical section **216a**, a fluted end **216b** having a point for drilling, and a collar stop **216c**. Drill bit **216** is particularly suited for drilling aperture **202** into implant **200**, as collar stop **216c** acts to prevent bit **216** from traveling too far into implant **200**, possibly damaging the device. Drill bit **216** may be helpful when drilling aperture **202** into a device such as implant **200a**, which has a different shaped structure, as can be seen in FIG. 17. Aperture **202** can be aligned in any suitable direction within the device. While aperture **202**

can be drilled into implant 200 before inserting the device into position in the spine, it may be advantageous to drill aperture 202 into implant 200 after it is positioned between vertebrae 210, 212. This would avoid weakening of implant 200, as the device is under compressive forces when in position. Alternatively, implant 200 could be manufactured with aperture 202 in place in the device.

[0088] Bone growth promoting substances can be used in many other arthroplasty devices. FIGS. 18A-B show its use in connection with an artificial disc replacement (ADR) procedure. An ADR device 220 similar to the device of FIGS. 12A-B contains a pair of extensions 221 for fixing device 220 in the spine and a pair of end plates 222a, 222b each having an aperture 223. End plates 222a, 222b are separated by an activating structure 226. End plates 222a, 222b may contain a series of channels which are connected to apertures 223. When device 220 has been positioned in place between vertebrae 210, 212, syringe 206 can be located with needle 208 inserted into apertures 223 of end plates 222a, 222b to input growth substance 207 into device 220 to promote bone ingrowth between the device and the vertebrae.

[0089] FIGS. 19 to 22A-B depict different arthroplasty devices which can be used in conjunction with bone growth promoting substances to maximize bone ingrowth between the body and the implants. An acetabular component for use in hip replacement is shown in FIG. 19. Component 240 is a cup-shaped device having a spherical outer surface 242 and a hollow curved inner surface 244. A front surface 246 contains a plurality of apertures 248. Apertures 248 are connected to a series of channels which are connected to a series of outlets 250 which are scattered along outer surface 242 of device 240. When component 240 is placed in position during hip replacement surgery, bone growth substance 207 can be injected into apertures 248 such that the substance can travel through the channels to outlets 250, where it can contact the hip bone to promote bone ingrowth between device 240 and the bone. An alternative embodiment to implant device 240 is shown in FIG. 21. This acetabular component 260 has a spherical outer surface 262, a hollow curved inner surface 264 and a flat front surface 266. Along the periphery of surface 266 a series of grooves 268 are channeled into outer surface 262. Grooves 268 may be parallel channels along outer surface 262, or they may spiral around outer surface 262. When component 260 is positioned in the bone during hip surgery, growth substance 207 may be injected into grooves 268 such that the fluid can flow between component 260 and the bone to promote bone ingrowth.

[0090] Examples of the present invention for use with femoral components are shown in FIGS. 20 and 22A-B. Referring now to FIG. 20, a femoral component 280 is shown having a body 282 having an outer surface 283, a flat top surface 284, and an outwardly extending stem 286. A plurality of apertures 288 are located on flat surface 284.

[0091] A series of channels within body 282 are connected to apertures 288 at one end, while the other ends are connected to a series of outlets 290 located on outer surface 283. When component 280 is implanted in position within a femur, bone growth substance 207 is injected into apertures 288 such that it will travel through body 282 and exit through outlets 290 between component 280 and the bone to

promote bone ingrowth. Alternative versions of this device are shown in FIGS. 22A-B. In FIG. 22A, femoral component 280a contains a body 282a having an outer surface 283a, a flat top surface 284a, and an outwardly extending stem 286a. Along the periphery of surface 284a, a plurality of grooves 292 are channeled into the outer surface 283a. Grooves 292 may be straight along outer surface 283a, or they can spiral around component 280a. When component 280a is fixed in place within a femur, growth substance 207 can be injected into grooves 292 such that the fluid can flow between the implant 280a and the bone to promote bone ingrowth. FIG. 22B shows a similar device 280b, except that grooves 294 are equally spaced around the periphery of upper surface 284b and are oriented in a parallel fashion along outer surface 283b.

[0092] The principles of the present invention taught in FIGS. 19-22B can be applied to other prosthetic devices such as knee replacements, shoulder replacement, and spinal fusion cages.

[0093] FIGS. 23A-D teaches several alternative embodiments of the present invention for use in spinal procedures similar to those taught in FIGS. 12A-B and FIGS. 18A-B. Referring now to FIG. 23A, there is shown a spinal device generally indicated at 300 having a pair of end plates 302a, 302b. Each end plate contains a keel-like fixation component 304 which is fixed for rotation about a pivot 306 through the interior area of the end plate. Component 304 are offset from each other with respect to device 300 such that component 304 rest side by side between end plates 302a, 302b when device 300 is in the unactivated position. This orientation allows for larger fixation components to be used in device 300 for better fixation in position between vertebrae. An activating component 308 is shown alongside device 300. Component 308 consists of a pair of spherical pusher plates 310. In operation, activating component 308 is forced between end plates 302a, 302b, causing fixation components 304 to rotate about pivot points 306 outwardly through end plates 302a, 302b, to extend from device 300 and holding the device firmly between vertebrae of the spine, as is shown in FIG. 23B.

[0094] FIGS. 23C-D show spinal device 300a in which slots 316 are incorporated into end plates 302a, 302b such that fixation components 304 rest within slots 316 when device 300a is in the unactivated state. Slots 316, which may be shaped such that the end of each fixation component 304 just fits within said slot, or may extend along a longer portion of each end plate, to allow for the use of a larger fixation component with device 300a, improving the holding power of spinal device 300a when positioned between vertebrae.

[0095] FIGS. 24A-D show an alternative embodiment for an arthroplasty device according to the present invention for use in hip surgery. Referring now to FIGS. 24A-C, there is shown a device 329 having a femoral component 330 with an outwardly extending stem 332, and a hollow passageway 334 extending through the central area of component 330. Passageway 334 is square shaped in this embodiment, but it may be shaped in any configuration in which a component inserted into said passageway cannot rotate, such as an ellipse, a triangle, pentagon, or hexagon. Component 330 also contains a recess 336 on its upper surface. Passageway 334 and recess 336 are connected by a channel 338. An

attachment component **340** contains an upper section **342** having a square shape with a threaded aperture **344** at its upper end and a lower threaded cylindrical section **346**. A screw **348** is also provided with the device.

[0096] To install femoral component **330** into a femur in a hip replacement procedure, the inner surface of femur **20** is threaded at the proper depth using a tool similar to that shown in FIG. 5A. Attachment component **340** is installed within femur **20** by threading section **346** into the femur. Component **330** is then located upon upper section **342** of attachment component **340** by matching the shape of section **342** with recess **334** in the proper orientation. Screw **348** is then inserted into recess **336** of component **330** through channel **338** and threaded into aperture **344** to hold the device in its proper position within femur **20**. This procedure "pulls" the device into the femur, helping to prevent fracturing the bone. A torque wrench may be used to adequately tighten screw **348** to its proper tightness to prevent splitting femur **20**. Attachment component **342** may be composed of a polymer such as carbon fiber, or alternatively may be composed of a resorbable material. Device **329** minimizes motion between the implant and bone, as the matched shape connection between passageway **334** and upper section **342** of attachment component **340** allows for virtually no movement.

[0097] An alternative attachment component **340a** for component **340** is shown in FIG. 24D. Component **340a** contains a similar upper section **342** containing a threaded aperture **344**; however, lower cylindrical threaded section **346a** contains a hollow internal section **352**. Hollow section **352** gives threaded section **346a** more flexibility than a solid component. Hollow threaded components and polymer threaded components are less likely to cause thigh pain from excessive stress transfer to the femur at the level of the threaded component. Furthermore, resorbable components, in particular, are less likely to cause stress shielding of the proximal femur.

[0098] FIGS. 25A-B show an embodiment of the present invention for use in a prosthetic knee device. Device **400** includes a cylindrical component **402** having a threaded outer surface and a recess **404** having a threaded inner surface. An articulating component **406** includes a planar section **408** having an extension **410** with a treaded end **412**.

[0099] To install device **400**, the internal surface of tibia **416** is threaded internally using a device similar to that shown in FIG. 5A at the desired depth. Component **402** is then threadably engaged within tibia **416**. Articulating component **406** is then threadably affixed to component **402** by threading end **412** of extension **410** into recess **404** until surface **408** contacts tibia **416**.

[0100] Referring now to FIG. 25B, prosthetic device **420** includes a cylindrical component **422** having a threaded outer surface and an aperture **423** having a threaded inner surface, and an upper component **424** having a planar surface **426** and an aperture **428** in the central region. The upper surface of component **424** is sized such that a cover **430** may be snapped into position on the upper surface. Cover **430** may be constructed of polyethylene. A bolt **432** having a head **433** is also included with device **420**.

[0101] To install device **420**, the internal surface of tibia **416** is threaded internally using a device similar to that

shown in FIG. 5A at the desired depth. Upper component **424** is placed on the upper surface of tibia **416** and bolt **432** is placed through aperture **428** and is threaded into aperture **423** of component **422** until head **433** contacts the upper surface of component **424**. Cover **430** is then snapped into position on component **424**.

[0102] In FIGS. 25A-B, components **402** and **422** may be composed of metal or a polymer, or could also be made from a resorbable material. Components **406** and **429** may be constructed from titanium or chrome cobalt.

[0103] FIG. 26 shows a device **444** embodying the present invention for use in treating the hip socket. In this embodiment, a fracture **450** of a femur **451** is shown at the base of the femoral head **452**. Device **444** includes a femoral repair component **453** consisting of a cylindrical member **454** having a threaded end section **456**. Component **453** also contains an aperture **458** which is oriented angularly toward femoral head **452**. Aperture **458** may be threaded internally. A second component **460** of device **444** consisting of a connecting rod **461** having a threaded end **462** is connected to femoral head **452** by a threaded aperture **464** within femoral head **452**.

[0104] To install device **444** for repair of the fractured femur, threaded end section **456** is located within femur **451** using the techniques previously discussed. The correct angular position of component **460** relative to component **453** and femoral head **452** is determined, and threaded end **462** is affixed within femoral head **452**. Rod **461** is sized such that the end can be inserted into aperture **458** of component **453** using a small amount of force to overcome the friction fit between the components. Rod **461** is then inserted into aperture **458** until femoral head **452** is positioned against femur **451**. The interaction between rod **461** and component **453** acts to hold head **452** in the correct position to heal.

[0105] FIGS. 27A-B show an embodiment of the present invention for use in repairing a fracture of the distal end of the femur. Repair device **480** includes a component **482** having a solid first section **484** with a threaded outer surface and a narrower cylindrical second section **486**. To install repair device **480**, the internal surface of femur **488** is threaded at a section on the opposite side of fracture **490** from distal end **492** of femur **488** using a device similar to that shown in FIG. 5A. Threaded section **484** of component **482** is affixed within femur **488** such that section **486** is spaced apart from distal end **492** of femur **488** when the two sections of femur **488** are held together tightly along fracture **490**. A hole **496** is then drilled across the distal end **492** of femur **488**, passing through section **486** of component **482**. A screw **498** is then placed into hole **496**, passing through section **486** of component **482** and is threaded into femur **488** as shown at **500**. This device holds the sections of femur **488** tightly together to aid in the healing process. Threaded section **484** can be made from a resorbable material, non-resorbable polymers, metal, or a combination of materials. For example, section **484** could be made with a metal core surrounded by a resorbable component.

[0106] The device **480a** of FIG. 27B is similar to device **480** shown in FIG. 27A except for the design of component **482**. Component **482a** is constructed like the component shown in FIG. 24D in that first section **484a** is hollow with a threaded outer surface. As discussed previously, the hollow

section allows more flexibility than a solid component. The installation of device **480a** follows the same methods of that taught for device **480**.

[0107] FIGS. 28A-C show a fixation device **500** for use in long bones. Referring now to FIG. 28A, a first component **502** contains a solid cylindrical portion **504** having an outer threaded surface **506**, and a cylindrical portion **508** having a lesser diameter than portion **504** and containing a threaded portion **510** located along its length. A second component **512** comprises a cylindrical disc having a threaded outer surface **514** and a central aperture **516** which is threaded. In addition, a pair of screws **520** are provided.

[0108] Fixation device **500** is shown on its installed position in FIG. 28B. A long bone **540** is shown having a fracture **542**. Threads are made on the internal surfaces of bone **540** in the appropriate positions in the manner previously described. Component **502** is then positioned within the upper section **540a** of bone **540** by engaging outer threaded surface **506** into the threaded position in section **540a** to fix component **502** in its proper location. Component **512** is then positioned onto threaded portion **510** of cylindrical portion **508** while component **512** is being threaded into lower section **540b** of bone **540**. Component **512** is rotated until it is firmly coupled to both component **502** and bone **540**. In this embodiment, left handed threads may be used for threaded **510** and also for threaded outer surface **514** and threaded aperture **516**. In this manner, the action of installing component **502** of device **500** acts to pull the components together. After device **500** has been installed in bone **540**, holes may be drilled into upper section **540a** and lower section **540b** through the upper and lower ends of component **502** and screws **520** inserted to prevent rotation of long bone **540** about device **500**.

[0109] FIG. 28C shows device **500** installed within long bone **540** without the use of screws **520**.

[0110] Another embodiment for use with the arthroplasty devices according to the present invention involves the use of bone cells. Bone and bone cells are grown onto the prosthesis prior to implanting the device into a patient. To accomplish this task, bone cells are initially harvested from a patient. Osteoblasts could be harvested from a patient's iliac crest; a piece of iliac crest bone could be surgically removed. In "Culture of Animal Cells" by R. Ian Freshney, Wiley-Liss New York 2000, which is incorporated herein by reference, techniques for harvesting osteoblasts are described on pps. 370-372. Also described in the article are cell culture techniques. U.S. Pat. No. 6,544,290, which issued on Apr. 8, 2003, to Lee et al, which patent is hereby incorporated by reference, teaches a method culturing cells onto a resorbing calcium phosphate material. The present invention contemplates the culturing of cells onto arthroplasty devices made of titanium, chrome, cobalt, ceramic, or other non-resorbable materials.

[0111] In the present invention, bone is harvested from a patient, and the bone then treated to remove the cells. The cells are cultured and grown onto the prosthesis in a lab. The device, now covered with living bone cells, is subsequently implanted into the patient. These cells, which include osteoblasts, osteocytes, donor bone cells, stem cells or other pluripotential cells, and other cells that are capable of transforming into osteoblasts or osteocytes, will promote the

bone ingrowth to improve the stability of the device in the body. Alternatively, the bone cells could be added to the device at the time of surgery.

[0112] To foster the improved bone ingrowth, the titanium components would have surface treatments. For example, the surfaces could be porous, beaded, plasma sprayed, or covered with fibrillar wire to promote ingrowth. Alternatively, the cells could be cultured onto arthroplasty devices made of other metals, or materials such as ceramic and hydroxyapatite coated metals. In addition, to attempt to improve the ingrowth characteristics of this process, bone growth promoting substances such as TGF- $\alpha$ , - $\beta$ 1, -2; EGF, IGF-I; PDGF, FGF, BMP-1, VEGF and other similar substances may be added to the cell culture medium.

[0113] It is contemplated that features of the various embodiments may be combined. For example, the expandable component taught in FIGS. 8A-B could be used with the threaded component of FIGS. 2-7. Also, although the drawings are directed primarily to the use of the invention in prosthetic hips, the principles may be applied to other prosthetic joints, such as knees, shoulders, ankles and wrists. In addition, bone cells harvested from the patient could be added to the bone growth promoting substance used in other embodiments. These cells could also be combined with a cell culture media or a synthetic matrix.

[0114] While the present invention has been shown and described in terms of preferred embodiments thereof, it will be understood that this invention is not limited to any particular embodiment, and that changed and modifications may be made without departing from the true spirit and scope of the invention as defined in the appended claims.

What is claimed is:

1. A prosthetic device for implanting into a bone, comprising:
  - a body having an outer surface, including a first section which contacts the bone upon implantation;
  - and a coating, covering at least said first section, containing living bone cells,
  - wherein when said device is implanted into bone, said living bone cells contact said bone to promote bone ingrowth between said device and said bone.
2. The device of claim 1, wherein said body is composed of titanium.
3. The device of claim 1, wherein said outer surface of said body is porous.
4. The device of claim 1, wherein said body is composed of a ceramic material.
5. The device of claim 1, wherein said body is composed of a hydroxyapatite-covered metal.
6. The device of claim 1, wherein at least said first section contains a textured surface.
7. The device of claim 6, wherein said textured surface comprises an array of beads.
8. The device of claim 6, wherein said textured surface comprises an array of fibrillar wires.
9. The device of claim 1, wherein said bone cells contain osteoblasts.
10. The device of claim 1, wherein said bone cells contain osteocytes.
11. The device of claim 1, wherein said coating contains a bone growth promoting substance.

**12.** The device of claim 11, wherein said bone growth promoting substance comprises at least one of the following substances: TGF- $\alpha$ ,  $\beta$ 1,-2; EGF, IGF-I; PDGF; FGF; BMP-1 and VEGF.

**13.** A method of implanting a prosthetic device into a bone of a patient, comprising the steps of:

- a. harvesting bone cells from a patient;
- b. culturing the bone cells within a lab;
- c. growing the bone cells onto a prosthetic device;
- d. implanting the prosthetic device into the bone of the patient.

**14.** This method of claim 13, wherein the harvesting step further includes removing a piece of iliac crest bone from the patient.

**15.** The method of claim 14, wherein the harvesting step further includes treating the iliac crest bone to remove the cells.

**16.** The method of claim 13, wherein said cells may be osteoblasts, osteocytes, and stem cells.

**17.** The method of claim 13, wherein the culturing step includes adding a bone growth promoting substance to the culture medium.

**18.** A method of implanting a prosthetic device into the bone of a patient, comprising the steps of:

- a. harvesting bone cells from a patient;
- b. culturing the bone cells within a lab;
- c. coating a prosthetic device with the bone cell culture; and
- d. implanting the prosthetic device into the patient immediately after coating.

**19.** The method of claim 18, wherein the culturing step includes adding a bone growth promoting substance to the culture medium.

\* \* \* \* \*