

C. ZUG.  
Apparatus for Annealing.

No. 197,508.

Patented Nov. 27, 1877.

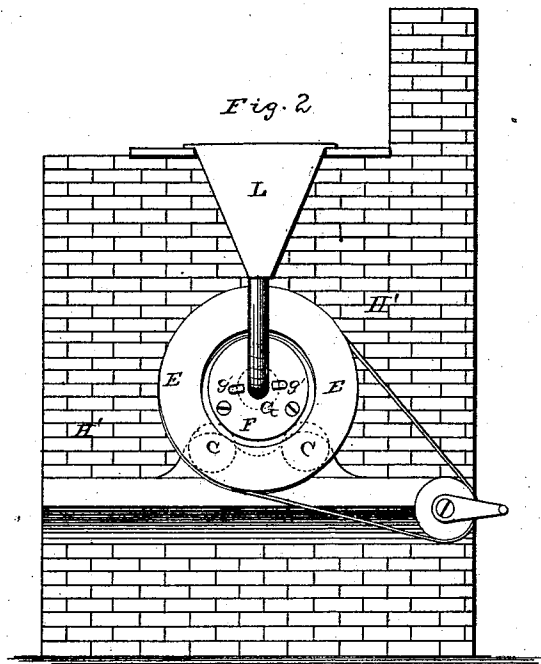
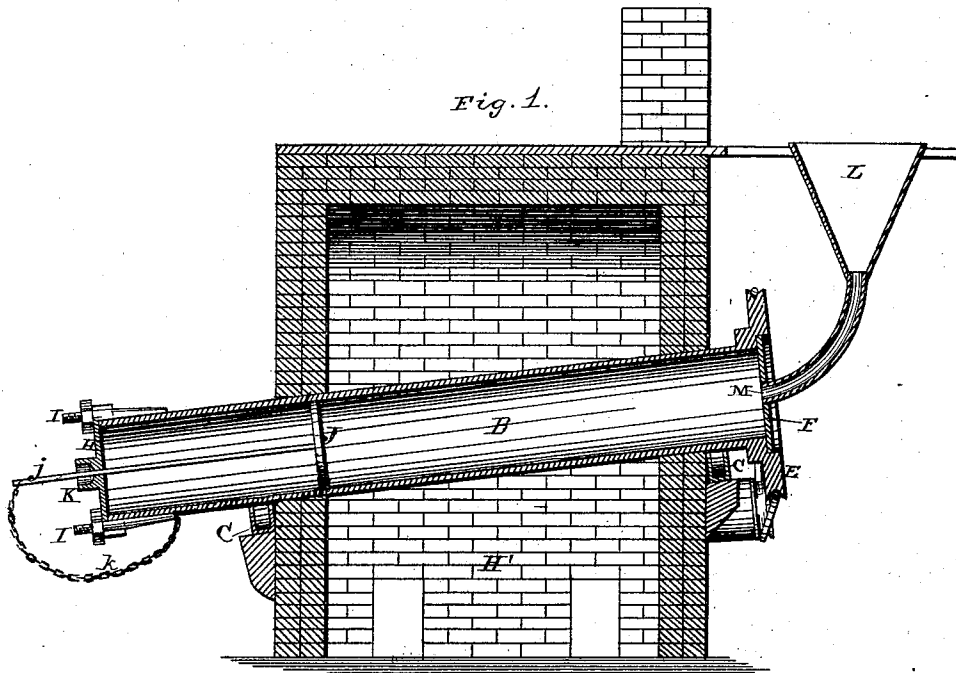

WITNESSES.

*J. W. Garner*  
*H. S. D. Gaines*

INVENTOR.

*C. Zug*  
*per*  
*F. A. Lehmann,*  
*att'y*

# UNITED STATES PATENT OFFICE.

CHRISTOPHER ZUG, OF PITTSBURG, PENNSYLVANIA.

## IMPROVEMENT IN APPARATUS FOR ANNEALING.

Specification forming part of Letters Patent No. 197,508, dated November 27, 1877; application filed October 26, 1877.

*To all whom it may concern:*

Be it known that I, CHRISTOPHER ZUG, of Pittsburg, in the county of Allegheny and State of Pennsylvania, have invented certain new and useful Improvements in Apparatus for Annealing; and I do hereby declare the following to be a full, clear, and exact description of the invention, such as will enable others skilled in the art to which it pertains to make and use it, reference being had to the accompanying drawings, which form part of this specification.

My invention relates to an improvement in annealing furnaces or ovens; and it consists in a rotating chamber closed at each end, and exposed to the heat of an ordinary arched furnace, in which chamber the nails are placed, not only to be exposed to the heat, but to be cleansed by the operation of rubbing against each other, as will be more fully described hereinafter.

Figure 1 is a vertical longitudinal sectional view of my invention. Fig. 2 is an end view of the same.

H' represents the furnace, which may be built in any desired shape or size, so as to obtain the best effect from the heat. Passing obliquely through this furnace is the annealing tube or pipe B, which is supported upon the friction-rollers C, placed at each end of the furnace, on the outside, as shown. Upon the upper end of this tube or pipe B is formed a suitable grooved collar or pulley, E, over which is passed a suitable belt or chain, for the purpose of causing the tube B to revolve at any desired rate of speed. Instead of the pulley or belt here shown for revolving the tube any other suitable mechanism may be employed for this purpose.

In the outer side of the pulley E is made a suitable recess, in which is placed the head or covering F, which closes the upper end of the tube or cylinder after the charge of nails or other articles which are to be annealed are placed therein. Through this head F is made an opening, M, which may either be closed with a movable cap, G, that is held in position by means of the movable lugs *g'* or in any other suitable manner. If so desired, this hole may also be covered with a piece of isinglass or any other suitable translucent

material, so that the condition of the charge may be inspected at any moment. When it is desired to charge this tube or cylinder with nails or any small articles the cap G is removed, and the end of the funnel L is inserted into the hole M.

The upper portion of the funnel will be supported in position by means of any suitable brace or support projecting from the top of the oven or any other source. The nails or other small articles having been poured into the funnel run down into the tube, and are exposed to the action of the heat in the furnace. As the tube revolves, the nails or other articles to be annealed gradually move down toward the lower end of the tube, and, by their constant friction and rubbing against each other, cleanse each other of all impurities that may be adhering to them. By being made to revolve constantly around they are more equably exposed to the heat and more thoroughly annealed.

The lower end of the tube B is provided with cap H, which is held in place by means of the nuts upon the screw I. Through the center of this cap is made an opening, K, through which passes the rod *j* of the stopper J. This stopper is inserted into the tube to any desired distance, so as to retain the first charge of nails or other articles to be annealed in a certain place in the tube. Were this stopper not used the articles would gradually gravitate toward the lower end of the tube, and thus gradually work beyond the influence of the heat in the furnace. After the process of annealing has continued long enough this stopper is withdrawn, the cap H replaced, the hole K has its center plugged up, so as to prevent any passage into the tube of oxygen, and the revolving of the tube recommenced. The first charge descends by gravitation to the lower end of the pipe, when the pipe is stopped revolving, a second charge inserted, and the revolving of the tube again begun. The first charge gradually cools in the lower part of the pipe while the second charge is heating.

When the cooling has been carried sufficiently far the cap H is removed, and the revolution of the tube causes the first charge to roll out at the lower end. In this manner

charge after charge is fed into the upper end of the tube and passed out at the lower one.

While the stopper J is in use it is retained in position by means of a chain, *k*, which is fastened to the tube B.

Having thus described my invention, I claim—

1. In combination with the inclined revolving tube B, placed in the furnace H', the stopper J *j*, substantially as described.

2. In combination with the revolving tube

B, the removable cap H, fastening devices I, cap F, stopper J, rod *j*, and chain *k*, substantially as set forth.

In testimony that I claim the foregoing I have hereunto set my hand this 18th day of October, 1877.

CHRISTOPHER ZUG.

Witnesses:

A. F. KEATING,

J. B. GEYSER.