

(19) World Intellectual Property
Organization
International Bureau



(43) International Publication Date
27 May 2004 (27.05.2004)

PCT

(10) International Publication Number
WO 2004/043514 A2

- (51) International Patent Classification⁷: **A61M**
- (21) International Application Number:
PCT/US2003/033511
- (22) International Filing Date: 23 October 2003 (23.10.2003)
- (25) Filing Language: English
- (26) Publication Language: English
- (30) Priority Data:
60/424,278 6 November 2002 (06.11.2002) US
- (71) Applicant (for all designated States except US): **MDC INVESTMENT HOLDINGS, INC.** [US/US]; Delaware Trust Building, 900 Market Street, Suite 200, Wilmington, DE 19801 (US).
- (72) Inventor; and
- (75) Inventor/Applicant (for US only): **MCWETHY, Robert, T.** [US/US]; 1543 Daffodil Avenue, Ventura, CA 93004 (US).
- (74) Agent: **ELAND, Stephen, H.**; Dann, Dorfman, Herrell and Skillman, 1601 Market Street, Suite 720, Philadelphia, PA 19103-2307 (US).
- (81) Designated States (national): AE, AG, AL, AM, AT, AU, AZ, BA, BB, BG, BR, BY, BZ, CA, CH, CN, CO, CR, CU, CZ, DE, DK, DM, DZ, EC, EE, EG, ES, FI, GB, GD, GE, GH, GM, HR, HU, ID, IL, IN, IS, JP, KE, KG, KP, KR, KZ, LC, LK, LR, LS, LT, LU, LV, MA, MD, MG, MK, MN, MW, MX, MZ, NI, NO, NZ, OM, PG, PH, PL, PT, RO, RU, SC, SD, SE, SG, SK, SL, SY, TJ, TM, TN, TR, TT, TZ, UA, UG, US, UZ, VC, VN, YU, ZA, ZM, ZW.
- (84) Designated States (regional): ARIPO patent (GH, GM, KE, LS, MW, MZ, SD, SL, SZ, TZ, UG, ZM, ZW), Eurasian patent (AM, AZ, BY, KG, KZ, MD, RU, TJ, TM), European patent (AT, BE, BG, CH, CY, CZ, DE, DK, EE, ES, FI, FR, GB, GR, HU, IE, IT, LU, MC, NL, PT, RO, SE, SI, SK, TR), OAPI patent (BF, BJ, CF, CG, CI, CM, GA, GN, GQ, GW, ML, MR, NE, SN, TD, TG).
- Published:**
— without international search report and to be republished upon receipt of that report
- For two-letter codes and other abbreviations, refer to the "Guidance Notes on Codes and Abbreviations" appearing at the beginning of each regular issue of the PCT Gazette.

(54) Title: PRE-FILLED RETRACTABLE NEEDLE INJECTION DEVICE

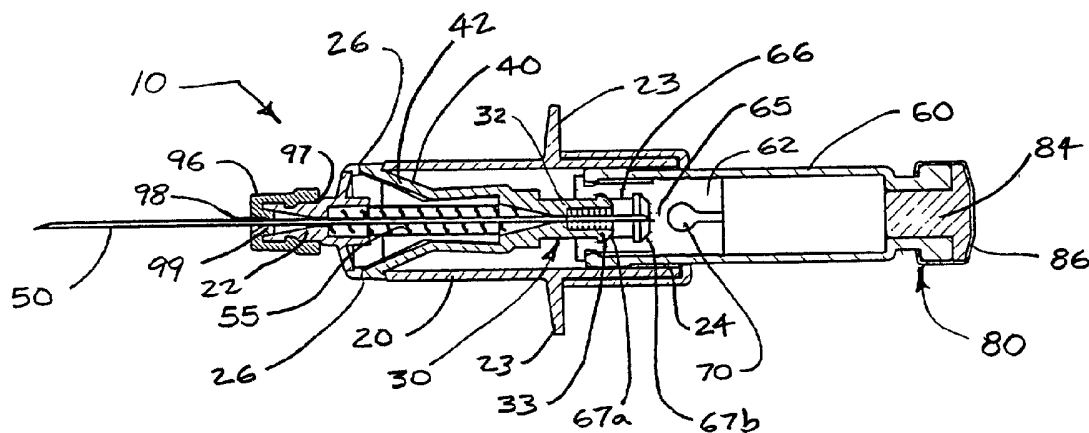

(57) Abstract: A medical device (10) is provided for injecting medicinal fluid from a fluid container (60), such as a cartridge, into a patient. The device includes a needle (50) that is retracted automatically after use so that the contaminated sharpened tip of the needle is enclosed within the device to prevent inadvertent needle sticks. One aspect of the invention is a lock (90) that prevents tampering with the needle after it is retracted. Another aspect of the invention is a cartridge that permits the entire device to be sterilized in one step.

WO 2004/043514 A2

PRE-FILLED RETRACTABLE NEEDLE INJECTION DEVICE

Field of the Invention

The present invention relates to pre-filled vials, ampoules, carpules, or cartridges for administering injections of medicinal fluids to patients. More specifically, the invention relates to such devices having a retractable needle feature for rendering the device non-reusable and safely disposable.

Background of the Invention

Various types of medical devices employ a needle for piercing the skin of a patient for diagnostic or therapeutic purposes. One such device is a cartridge injector. Cartridge injectors utilize pre-filled cartridges that have a pre-measured dose of medication. The cartridge injector is used to inject the medication from the cartridge into a patient.

Handling of such needle-bearing medical devices after the needle is withdrawn from the patient can result in transmission of various pathogens, most notably human immunodeficiency virus (HIV), to uninfected medical personnel, due to an inadvertent needle stick. Accordingly, it is desirable to provide a device for injecting medication from a pre-filled cartridge, wherein the injection needle is retracted into the housing of the device after use.

There are numerous retractable needle medical devices disclosed in the prior art. Typically, to effectuate retraction, the prior art devices require manual actuation by the operator. In many situations, such as an emergency situation, the operator is distracted or rushed so that the manual step necessary to effectuate retraction is not performed, either intentionally or unintentionally. In such instances, the used needle remains exposed, creating a risk of an inadvertent needle stick. Therefore, it is desirable to

provide an automatic needle retraction mechanism in which needle retraction is effectuated by normal operation of the device without the need to perform a separate manual step. It is further desirable to provide a device that substantially prevents tampering with the needle after it is retracted.

5

Cartridge injectors are typically assembled by connecting a pre-filled cartridge to a needle injector. Pre-filled cartridges in the present state of the art generally have one open end that is used to fill the cartridge with medication and provide a fluid path from the cartridge to the needle. The opening to the cartridge is generally not accessible once the cartridge is connected to the needle injector. Therefore, the cartridge must be filled with medication prior to being connected to the needle injector. Moreover, the cartridge is sterilized before it is filled with medication and connected to the needle injector, and the needle injector is sterilized before the cartridge is fluidly connected to the needle injector. As a result, the needle injector and the cartridge are sterilized separately in the manufacturing process. It is desirable to sterilize all the components of the device in one step and at one facility to reduce manufacturing costs.

20 **Summary of the Invention**

In accordance with a first aspect of the present invention, there is provided a medical device for injecting medicinal fluid from a fluid container, such as a cartridge, into a patient. The device includes a needle that is retracted automatically after use so that the contaminated sharpened tip of the needle is enclosed within the device to prevent inadvertent needle sticks. In one embodiment of the invention, the device provides a lock that prevents tampering with the needle after it is retracted. In another embodiment of the invention, the device utilizes a cartridge that permits the entire device to be sterilized in one step.

30

The device includes a hollow housing having a generally open rearward end forming a socket. A cartridge configured to hold a quantity of medicinal fluid is adapted to engage the socket. The needle for injecting the fluid is operable between a projecting position in which the sharpened tip of the needle projects forwardly from the housing, and a retracted position in which the sharpened tip is enclosed within the housing. A biasing element biases the needle toward the retracted position. A needle retainer releasably retains the needle in the projecting position. The needle retainer is operable between a locked position and an unlocked position. In the locked position, the needle retainer releasably retains the needle in the projecting position against the bias of the biasing element. In the unlocked position, the needle is released, allowing the biasing element to displace the needle rearwardly.

The cartridge cooperates with the needle retainer so that upon forward displacement of the cartridge, the cartridge engages the needle retainer, displacing the needle retainer from the locked position to the unlocked position. A lock ring on the rearward end of the housing substantially prevents removal of the cartridge or needle from the housing after retraction.

The present invention also provides a method for manufacturing a medical device. The method includes the following steps. A needle injection component is fabricated having a hollow body. A fluid container is also fabricated having a sealed end and an open end. The sealed end of the fluid container is then connected to the hollow body of the needle injection component. Once the fluid container is connected to the needle injection component, the two components are sterilized together in one step. After sterilization, medicinal fluid is dispensed into the fluid container through the open end of the fluid container. The open end of the fluid container is then closed to enclose the fluid in the container.

30

Description of the Drawings

All of the objects of the present invention are more fully set forth hereinafter with reference to the accompanying drawings, wherein:

5

Fig. 1 is a sectional view of a medical device in accordance with the present invention.

10

Fig. 2 is a sectional view of the device in Fig. 1 with optional covers for limiting access to the front and rear ends of the device.

Fig. 3 is a sectional view of the device in Fig. 1, showing the device prepared for injecting a medication into a patient.

15

Fig. 4 is a sectional view of the device in Fig. 1, showing the device at the end of an injection stroke.

Fig. 5 is a sectional view of the device in Fig. 1, showing the device after the needle is retracted into the device.

20

Fig. 6 is an alternate sectional view of the device shown in Fig. 5 rotated approximately 90° relative to Fig. 5.

Fig. 7 is a partially exploded sectional view of the device shown in Fig. 2.

25

Fig. 8 is an enlarged fragmented sectional view of a portion of the device in Fig. 7.

Description of the Preferred Embodiment

30

Referring now to the drawing figures in general, and to Fig. 1

specifically, there is shown a cartridge injector 10 with an attached cartridge 60 that is pre-filled with medication. The cartridge injector 10 includes a needle 50 with a sharpened tip for inserting the needle into a patient. The needle 50 is in fluid communication with the medicine in the cartridge 60. By pressing the cartridge 60 into the cartridge injector 10, the medicine is expelled from the cartridge and into the patient through the needle 50. After the medicine is administered to the patient, the needle 50 may be retracted into the body of the cartridge injector 10 automatically.

Referring to Figs. 1-2, the device includes a generally cylindrical housing 20, a needle 50, a spring 55 biasing the needle rearwardly, and a needle retainer 40 releasably retaining the needle against the bias of the spring. The needle is operable between two positions: a projecting position and a retracted position. In the projecting position, the needle 50 projects forwardly from the forward end of the housing 20. In the retracted position, the needle is retracted into the housing 20 so that the sharpened tip of the needle is enclosed within the housing to prevent inadvertent contact with the sharpened tip. When the needle is in the projecting position, as shown in Fig. 1, the spring biases the needle rearwardly toward the retracted position. The needle retainer 40 releasably retains the needle in the projecting position, against the bias of the spring. The needle retainer 40 cooperates with the cartridge 60, so that when the cartridge is displaced forwardly at the end of an injection stroke, the needle retainer automatically releases the needle, permitting the needle to retract into the housing, as shown in Figs. 5-6.

Referring now to Figs. 1-3, the elements of the device 10 will be described in greater detail. The device 10 has a cartridge 60 with forward and rearward open ends. The forward open end is sealed by a front seal 96 that has an opening sized to cooperate with the outside of the needle 50 to form a sterile barrier. The rearward open end provides an opening 80 that permits the cartridge 60 to be filled with a medication after the cartridge is connected to the housing 20. In this way, the housing 20 and cartridge 60

may be assembled and sterilized together in one step prior to filling the device 10 with medication if desired, as discussed further below.

5 Medicine may be dispensed in the cartridge 60 through the rear opening. The rear opening 83 is adapted to receive a flexible stopper 84 that closes the rear end 80 after the cartridge 60 is filled with medication. The flexible stopper 84 is configured to engage the opening to maintain a barrier seal to prevent contaminants from entering the cartridge and minimize leakage through the rear end of the cartridge 60. Preferably, the end of the stopper 84 forms a head that flares outwardly. The head of the stopper abuts against the circumferential collar at the rearward end of the container.

15 The stopper 84 may be covered by a cap 86, as shown in the Figures, to maintain the stopper in place in the rearward opening. The cap 86 covers the stopper 84 and rearward end of the cartridge 60. The cap 86 is made of a thin malleable material, such as a thin piece of stainless steel or aluminum, that may be crimped around the rear end 80 of the cartridge 60. The cap 86 is configured to be pressed or crimped around a circumferential collar 82 at the rearward end of the cartridge and the stopper 84 to secure the cap and stopper on the rearward end of the cartridge.

25 The housing 20 is generally cylindrical and the forward end of the housing has a reduced diameter tapered nose 22. The nose 22 has an opening through which the needle 50 projects outwardly from the housing 20 so that the sharpened tip of the needle can be inserted into a patient for administering medication to the patient. Prior to use, a needle cap 11 is placed on the housing 20 to enclose the portion of the needle 50 that projects from the housing, as shown in Fig. 2. Needle cap 11 is configured to cover the sharpened forward tip of the needle 50 and limit the potential for inadvertent needle sticks or contamination of the needle prior to use. The needle cap 11 may cover the needle and the forward portion of the housing 20, as shown in Fig. 2. Alternatively, the needle cap 11 simply covers the

projecting needle 50. An optional rear cover 12 may be placed on the housing 20 and over the rear portion of the cartridge 60 to limit access to the rear end of the cartridge.

5 The rearward end of the housing 20 is open, forming a cylindrical socket 24 for receiving the cartridge 60. Two laterally extended flanges 23 project outwardly from the housing 20, transverse the longitudinal axis of the housing, forming two finger grips for operating the device. The housing further includes a pair of locking apertures 26 that cooperate with the needle
10 retainer as described further below.

 A hub 30 is disposed within the housing 20. The needle 50 is fixedly attached to the hub 30. Specifically, the hub 30 is a generally cylindrical element having a central bore. The needle 50 is a double ended needle, so
15 that both ends of the needle are sharpened. The needle 50 is disposed within the central bore of the hub 30 so that the forward portion of the needle projects forwardly from the hub and the rearward portion of the needle projects rearwardly from the hub. The needle 50 can be attached to the hub
20 30 in one of several ways. For instance, the needle 50 may be attached to the hub 30 by an adhesive such as a UV curable epoxy. Alternatively, the needle can be molded into the hub, which is formed of plastic. The rearward end of the hub 30 forms a stem 32 configured to cooperate with the cartridge 60, as discussed further below.

25 As shown in Fig. 1, the spring 55 circumscribes the needle 50. A forward end of the spring 55 bears against the interior of the nose 22. The rearward end of the spring 55 bears against the forward end of the hub 30. The hub 30 is axially displaceable within the housing 20. Prior to retraction, however, the hub 30 is retained in a fixed axial position relative to the housing
30 20 by the needle retainer 40. The hub is retained in the fixed axial position while the medication is expelled from the cartridge 60. After use, the hub 30 and the attached needle 50 are displaced rearwardly in the housing 20.

The needle retainer 40 is operable between a locked position and an unlocked position. In the locked position, the needle retainer 40 releasably retains the hub 30 and the attached needle 50 in a fixed axial position relative to the housing 20 so that the needle projects forwardly from the housing.

5 More specifically, in the locked position, the needle retainer 40 engages the housing 20 to retain the hub 30 and the attached needle 50 against the rearward bias of the spring 55. In the unlocked position, the needle retainer 40 allows the hub 30 and the needle 50 to be retracted rearwardly. More specifically, in the unlocked position, the needle retainer 40 is disengaged

10 from the housing 20, so that the spring 55 propels the needle and the attached hub 30 rearwardly.

The needle retainer 40 comprises a pair of elongated resilient arms 42. The arms 42 project forwardly and radially outwardly into engagement with

15 the locking apertures 26 formed in the side of the housing 20. The terminal end of each arm 42 forms a locking tab or detent 44. The locking tabs 44 project into the apertures 26 of the housing 20. Each aperture 26 forms a lip or rim which engages a locking tab 44. In this way, the locking tabs 44 operate as a pair of latches to retain the hub 30 and the attached needle 50

20 forwardly against the bias of the spring 55.

Although in the preferred embodiment the needle retainer 40 comprises a pair of arms having latches to engage the housing. It is recognized that other types of elements can be used to retain the needle 50

25 against the bias of the spring 55. For instance, the needle retainer 40 may comprise a single latch, a friction element for frictionally retaining the needle and/or the hub, or a ball and detent arrangement.

Referring to Figs. 2 and 3, the rearward end of the housing 20 is

30 generally opened, forming a socket for receiving the cartridge 60. The cartridge 60 is a generally cylindrical vessel containing an amount of medicinal fluid. In the present instance, the cartridge is formed of a rigid

material such as glass. The cartridge 60 has a wide diameter section 68 at the forward end and a narrow diameter section 69 extending rearwardly from the wide diameter section. The wide diameter section 68 assists in preventing disassembly of the cartridge and housing, as explained in more
5 detail below.

The forward open end of the cartridge 60 is sealed by a rubber piston or seal 62. The seal 62 is generally cylindrical and preferably has a plurality of axially-spaced circumferential ribs that form a fluid-tight seal between the seal
10 62 and the internal surface of the cartridge 60. The seal 62 is configured to cooperate with the mounting stem 32 on the hub 30 to connect the housing 20 to the cartridge 60. In the present instance, the mounting stem 32 has a barb 33, and the seal 62 has a corresponding socket 66. However, alternative connectors can be used, such as a threaded connection, a
15 frictional connection could also be used.

The rear end of the seal 62 includes a recess 70 that communicates with the interior of the cartridge. A pierceable wall or septum 65 is formed in the seal 62 between the socket 66 and the recess 70. When the cartridge 60
20 is mounted on the mounting stem 32, the rear sharpened end of the needle 50 pierces the septum 65 and extends into the recess 70 formed in the interior of the seal 62. The recess 70 opens to the interior of the cartridge 60 so that when the needle 50 projects into the recess, the needle is in fluid communication with the interior of the cartridge, allowing medication to flow
25 from the cartridge into the needle. After the needle 50 pierces the wall 65 of the seal 62, the wall forms a fluid-tight seal between the seal and the side of the needle to prevent medication from leaking into the housing 20.

The socket 66 in seal 62 matingly engages the barb 33 of mounting
30 stem 32. Specifically, the socket 66 includes two radially relieved portions or recesses that mate with the head of the barb 33. A first radial recess 67a is formed in the seal 62 toward the front end of the seal , and a second radial

recess 67b is formed in the interior of the seal adjacent to the septum 65. As shown in Fig. 2, prior to use, the cartridge 60 is connected to the mounting stem 32 so that the head of the barb 33 engages the first radial recess 67a in the socket. In this position, the needle 50 does not pierce the septum 65 of the piston 60. To prepare the device 10 for use, the medical professional displaces the cartridge 60 forwardly relative to the mounting stem 32, thereby displacing the head of the barb 33 into engagement with the second radial recess 67b, as shown in Fig. 3. At the same time, the needle pierces the septum 65, so that the needle 50 is in fluid communication with the medicament in the cartridge 60.

The connection between the cartridge 60 and mounting stem 32 is preferably a one-way engagement. In other words, when the cartridge 60 is mounted on the mounting stem 32, the cartridge can be displaced forwardly relative to the mounting stem 32, but the cartridge can not be displaced rearwardly relative to the mounting stem. In this way, the cartridge 60 cannot be readily removed from the mounting stem 32, such that the cartridge is substantially permanently attached to the mounting stem.

The one-way connection is provided by a one-way sliding engagement between the barb 33 and the radial recesses 67a, 67b in seal 62. The barb 33 has rearward-facing tapered edges that mate with tapered faces in the radial recesses 67a, 67b. The barb 33 also has sharp or square forward facing edges that mate with square edges in the radial recesses 67a, 67b. The tapered edges on the barb 33 and radial recesses 67a, 67b are tapered in the rearward direction, permitting rearward sliding displacement of the stem 32 relative to the seal 62. The square edges on the barb 33 and in the recesses 67a, 67b operate as stops that impede forward displacement of the stem 32 relative to the seal 62.

The medication may be expelled from the cartridge 60 by moving the

cartridge axially forwardly relative to the housing 20. The seal 62 is mounted on the barb 33 of the mounting stem 32 so that the seal remains stationary relative to the housing 20 while the cartridge 60 is advanced. The seal 62 is configured to form a sliding fit with the interior of the cartridge so that the cartridge can slide over the seal to expel the medication from the cartridge. Additionally, the circumferential ribs maintain a fluid tight seal between the seal 62 and the cartridge 60 while the cartridge slides over the seal.

As the cartridge 60 is advanced, the medication in the cartridge flows out of the cartridge and into the needle 50. The medication is expelled from the needle 50 and injected into the patient. As described further below, after the medication is injected into the patient, the needle 50 is retracted into the housing 20 so that the forward sharpened tip of the needle is enclosed within the housing.

Referring now to Figs. 3-6, the actuation of the needle retainer 40 will be described. The forward end of the cartridge 60 forms a rim 61. As the cartridge 60 is axially advanced, the rim 61 of the cartridge is displaced into engagement with the arms 42 of the needle retainer 40. When the barb 33 engages the second radial recess 67b, the distance between the rearward end of the seal 62 and the rearward interior end of the cartridge 60 corresponds to the distance between the rim 61 of the cartridge and the needle retainer arms 42. In this way, the rim 61 of the cartridge 60 engages the needle retainer arms 42 when substantially all of the medication is expelled from the cartridge 60. After the rim 61 of the cartridge 60 engages the needle retainer arms 42, continued axial advancement of the cartridge displaces the arms 42 radially inwardly so that the locking tabs 44 are displaced inwardly, disengaging the locking tabs 44 from the locking apertures 26 of the housing 20, as shown in Fig. 4. In this way, the cartridge 60 operates as an actuator such that axial advancement of the cartridge displaces the needle retainer 40 into the unlocked position. The spring 55 is of sufficient force to overcome the friction between the locking tabs 44, the

guide arms 38 and the interior of the housing 20. After the needle retainer 40 is in the unlocked position and the user releases the cartridge 60, the spring 55 propels the needle 50 rearwardly until the forward sharpened tip of the needle is enclosed within the housing 20, as shown in Fig. 5.

5

Referring now to Figs. 5-6, when the needle 50 is retracted, the needle, the hub 30, and the cartridge 60 are displaced rearwardly together. Accordingly, the device 10 preferably includes a mechanism for limiting the rearward travel of the retracted elements. In addition, the device 10 preferably includes an element for limiting the forward displacement of the needle 50 after retraction to prevent the contaminated needle from being re-extended from the housing 20.

10

Referring now to Fig. 6, the device 10 includes a pair of guide arms 38 formed of a resilient flexible material. The guide arms 38 cooperate with a pair of channels 28 that extend longitudinally along the interior wall of the housing 20. The guide arms 38 are integrally formed with the hub 30 and are compressed inwardly in the housing 20. As a result, the resilient guide arms 38 are biased radially outwardly into the channels 28 such that the ends of the guide arms project radially outwardly into engagement with the channels. The guide arms 38 cooperate with the channels 28 to constrain the hub against rotational displacement relative to the housing. In this way, the hub 30 is limited to axial displacement in the housing 20.

15

20

As shown in Fig. 6, the rearward end of each channel 28 aligns with a lockout window 29 that extends through the wall of the housing 20. The lockout windows 29 receive the ends of the guide arms 38 as the guide arms are retracted to the rearward end of the housing 20. More specifically, the ends of the guide arms 38 are configured to slide in the channels 28 during retraction until they reach the lockout windows 29. Upon reaching the lockout windows 29, the ends of the guide arms 38 are no longer compressed inwardly by the interior wall of the housing 20. As a result, the guide arms 38

25

30

5 snap outwardly into engagement with the lockout windows 29. The forward ends of the lockout windows 29 bear against the guide arms 38 to retain the guide arms, hub 30 and needle against forward displacement. In this way, the lockout windows 29 provide a lockout feature that substantially prevents re-advancement of the needle 50 after the needle is retracted in the housing 20.

10 Preferably, the device 10 has a mechanism that limits the potential for tampering with the lockout feature. Referring to Figs. 4-6, the device 10 is shown with a generally cylindrical lock ring 90 circumscribing the rearward end of the housing 20. The lock ring 90 covers the lockout windows 29 to impede access to the ends of the guide arms 38 that project through the lockout windows. In this way, the ends of the guide arms 38 can not be pushed back through the windows 29 and into the housing to release the
15 guide arms and permit re-advancement of the needle 50 after retraction. The lock ring 90 is configured to be placed over the exterior of the housing 20 after the cartridge 60 is connected with the housing. More specifically, the lock ring 90 has a bore adapted to slide onto the exterior of the housing. An annular rim 91 at the rear end of the lock ring 90 contacts the rear end of the
20 housing 20 and the cartridge 60 to substantially prevent disassembly of the device 10, as explained in more detail below.

25 Referring to Fig. 6, the lock ring 90 has a pair of detents 92 that extend radially inwardly to secure the lock ring on the housing. The detents 92 are configured to slidably engage the exterior of the housing 20 and snap into the lockout windows 29 as the lock ring 90 is mounted on the housing. The detents 92 have forward edges that abut the rear ends of the guide arms 38 when the guide arms and hub 30 are in the retracted position. The detents 92 also have rear edges that engage the rear ends of the lockout windows 29.
30 As such, the detents 92 provide stops that limit further rearward displacement of the guide arms 38 after the guide arms are retracted into the lockout windows 29.

As discussed earlier, the cartridge 60 has an enlarged diameter section 68 at the forward end of the cartridge and a reduced diameter section 69 adjacent to the enlarged diameter section. The transition between the wide diameter section 68 and narrow diameter section 69 forms a circumferential lip or shoulder 93 on the exterior of the cartridge, as shown in Fig. 8. The lip 93 aligns with the annular rim 91 on the lock ring 90 and is configured to substantially prevent separation of the cartridge from the housing. More specifically, the annular rim 91 extends radially inwardly to contact the lip 93 when the needle 50, hub 30 and cartridge 60 are retracted rearwardly. As such, the rim 91 provides a stop limiting rearward displacement of the needle 50 and preventing separation of the cartridge 60 from the housing 20 after the needle is retracted.

The device 10 preferably has one or more barriers that form a seal around the device. Referring to Figs. 1-2, a seal cover 96 is shown disposed over the exterior of nose 22 on housing 20. The seal cover 96 cooperates with the needle cap 11 to provide a sterile barrier to prevent contaminants from contaminating either the insertion end of the needle or the fluid path of the needle. The seal cover 96 has a large bore 97 that fits around the exterior of the nose 22. The seal cover 96 also has a small bore 98 through which the needle 50 extends when the needle is in the projecting position. The small bore 98 is formed by a cylindrical collar 99 recessed inwardly in the interior of the seal cover. The inner diameter of the small bore 98 is slightly less than the outer diameter of the needle so that the cover 96 engages the needle to provide a sterile barrier. The seal cover 96 may be manufactured using any appropriate method and material, such as a molded plastic or an elastomeric material.

Configured as described above, the device has several seals that prevent contaminants from contaminating the patient end of the needle, the fluid path of the needle, or the interior of the cartridge. Specifically, the nose seal 96 forms a seal with the exterior of the barrel 20, and with the interior of

the needle cap 11, so that contaminants cannot enter the needle through the forward end of the needle, or contaminate the patient end of the needle. Further, the seal 62 in the cartridge forms a seal with the interior of the cartridge and the exterior of the rearward end of the needle to prevent contaminants from entering the needle through the rearward end of the
5 needle, or contaminate the interior of the cartridge. In addition, the adhesive bond between the hub 30 and the exterior surface of the needle or the molding of the needle into the hub preferably acts as a barrier to prevent contaminants from moving along the exterior of the needle toward the
10 cartridge. Because of the barrier seals in the device, the device need not be separately packaged in sterile packaging to maintain the sterility of the device.

Preferably, the device is produced as follows. The injector 10 is assembled and then the cartridge 60 is inserted into the injector. Preferably,
15 the cartridge is inserted into the injector before it is filled with medication. The injector and cartridge are then sterilized and the cartridge is then filled with medication in an aseptic fill area. After filling, the cartridge is capped so that the device is ready for use as shown in Fig. 1.

20 More specifically, preferably the device is produced by assembling the injector 10 by attaching the nose seal 96 to the front end of the housing. The housing and nose seal are then placed over the rearward end of the needle, so that the rearward end of the needle projects into the barrel. Since the
25 housing is placed over the rearward end of the needle, there is less risk of damaging or dulling the patient end of the needle during assembly. The spring is then inserted into the rearward end of the housing, over the rearward end of the spring. The hub 30 is then inserted into the housing through the rearward end so that the hub compresses the spring. The hub is displaced
30 forwardly until the needle retainer arms 42 engage the locking apertures 26 in the housing. The hub 30 is then bonded with the needle to fix the needle to the hub. After the needle is bonded to the hub, the locking ring 90 is attached

to the rearward end of the housing so that the locking ring surrounds the rearward end of the housing. The needle cap 11 is placed over the patient end of the needle to protect the needle against contact that could dull the needle.

5

The cartridge 60 with the seal 62 is inserted into the injector so that the seal 62 engages the mounting stem 32 on the hub 30 to attach the cartridge to the injector. The cartridge may be attached after it is filled with medication. However, preferably, the cartridge is attached before being filled.

10

Accordingly, preferably the cartridge is attached to the injector without the attached rearward seal 84 and cap 86. Therefore, the rearward end of the cartridge is open for being filled. The cartridge and injector can be sterilized separately and then combined. However, preferably cartridge and attached cartridge are sterilized together as a unit.

15

In a sterile environment, medication is then dispensed into the cartridge through the rearward open end of the cartridge. After filling, in the sterile environment, the seal 84 is inserted into the rearward end of the cartridge to seal the cartridge. If desired, a cap 86 is placed over the seal, around the rearward end of the cartridge, to fix the rearward seal in place.

20

The device 10 is operated as follows. The needle cover 11 and rear cover 12 are removed from the device to expose the needle 50 and the rear end of the cartridge 60. At this point, the barb 33 on the hub 30 is disposed in the first radial recess 67a in the seal 62. To prepare the device 10 for an injection, axial pressure is applied to the rearward end of the cartridge 60 to advance the cartridge forwardly relative to the hub 30. Axial pressure is applied until the seal 62 slides over the barb 33 so that the barb slides into the second radial recess 67b in the seal. At the same time, the rear sharpened tip of the needle 50 pierces the septum 65 and enters the recess 70 in the cartridge 60 to be in fluid communication with the interior of the cartridge.

25

30

Once the rearward end of the needle 50 is in fluid communication with the interior of the cartridge 60, the needle is ready for administering medication to a patient. Prior to inserting the needle 50 in a patient, the cartridge 60 may be advanced to expel trapped air from the needle. The
5 needle 50 is then inserted into a patient. To begin the injection stroke, axial pressure is applied to the rearward end of the cartridge 60 to discharge medication through the needle 50 and into the patient.

At the end of the injection stroke, the forward rim 61 of the cartridge 60
10 displaces the needle retainer arms 42 radially inwardly to disengage the needle retainer arms from the apertures 26 in the housing 20. However, the needle 50 does not retract until axial pressure is released from the rearward end of the cartridge 60. Once pressure is released from the cartridge 60, the spring 55 propels the needle 50 rearwardly so that the contaminated forward
15 tip of the needle is enclosed in the housing 20. Accordingly, the medical professional can control the timing of needle retraction after the injection is completed. For instance, the medical professional may desire to remove the needle from the patient before retracting the needle into the housing 20. In such a case, the medical professional retains finger pressure on the cartridge
20 until after the needle is withdrawn from the patient. The medical professional then releases finger pressure from the cartridge 60 so that the spring 55 automatically retracts the needle 50. Alternatively, the medical professional may desire to retract the needle directly from the patient into the housing 20. In this case, the medical professional releases finger pressure on the
25 cartridge 60 after the needle retainer 40 is disengaged from the housing 20 and while the needle 50 is still inserted into the patient. The spring 55 then retracts the needle 50, thereby withdrawing the needle from the patient and into the housing 20.

30 During retraction, the spring displaces the hub 30 and cartridge 60 rearwardly. The guide arms 38 on the hub 30 slide rearwardly in the housing 20 until the guide arms snap into the lockout windows 29. The rear edges of

the guide arms 38 engage the forward edges of the detents 92 on the lock ring 90, preventing further displacement of the hub and needle 50. At this time, the needle 50 and hub 30 are fully retracted into the housing. The forward edges of the guide arms 38 engage the forward edges of the lockout windows 29 to prevent re-advancement of the needle 50 after retraction. The wide diameter section of the cartridge 60 engages the annular rim 91 on the lock ring 90 to substantially prevent separation of the cartridge from the housing 20.

10 The terms and expressions which have been employed are used as terms of description and not of limitation. There is no intention in the use of such terms and expressions of excluding any equivalents of the features shown and described or portions thereof. It is recognized that various modifications are possible within the scope and spirit of the invention.

15 Accordingly, the invention incorporates variations that fall within the scope of the following claims.

That Which Is Claim Is:

1. A medical device, comprising:
 - a hollow housing having a generally open rearward end forming a socket;
 - a fluid container containing a quantity of medicinal fluid, the fluid container being adapted to engage the socket;
 - a needle having a sharpened tip, wherein the needle is displaceable between a projecting position in which the sharpened tip projects forwardly from the housing and a retracted position wherein the sharpened tip is enclosed within the housing;
 - a biasing element biasing the needle toward the retracted position;
 - a needle retainer operable between a retaining position in which the needle retainer releasably retains the needle in the projecting position against the bias of the biasing element and an release position in which the needle is released allowing the biasing element to displace the needle rearwardly;
 - a lock for locking the needle in the retracted position to impede displacement of the needle after the needle is displaced into the retracted position; and
 - a guard covering the lock to prevent manipulation of the lock to release the needle;wherein upon forward displacement of the fluid container, the fluid container engages the needle retainer displacing the needle retainer from the locked position to the unlocked position.
2. The device of claim 1, wherein the needle retainer comprises a latch biased radially outwardly, releasably engaging the housing.
3. The device of claim 1 wherein the lock comprises a guide arm connected to the needle and biased radially outwardly from the needle into engagement with a channel in the interior wall of the housing,

wherein the engagement between the guide arm and the channel substantially prevents rotational displacement of the needle retainer in the housing.

4. The device of claim 3, wherein the lock comprises a window in the wall of the housing, and the guide arm is configured to engage the window when the needle is displaced to the retracted position.
5. The device of claim 4 wherein the guard circumscribes at least a portion of the housing to cover the window.
6. The device of claim 1, wherein the fluid container contacts the guard to substantially prevent separation of the fluid container from the housing.
7. A medical device, comprising:
 - a hollow housing having a rear socket;
 - a fluid container adapted to engage the socket on the housing, said container having an open rear end through which a medicinal fluid may be deposited while the fluid container engages the socket;
 - a needle having a sharpened tip, wherein the needle is displaceable between a projecting position in which the sharpened tip projects forwardly from the housing and a retracted position wherein the sharpened tip is enclosed within the housing;
 - a biasing element biasing the needle toward the retracted position;
 - a needle retainer operable between a locked position in which the needle retainer releasably retains the needle in the projecting position against the bias of the biasing element and an unlocked position in which the needle is released allowing the biasing element to displace the needle rearwardly; andwherein upon pushing forwardly upon the fluid container, after ejection

of the fluid the needle retainer is displaced from the locked position to the unlocked position.

8. The medical device of claim 7 further comprising a stopper configured to close the open rear end of the fluid container in a fluid tight seal.
9. A method of manufacturing a medical device, comprising the steps of:
fabricating a needle injector with a hollow body;
fabricating a fluid container having a sealed end and an open end;
connecting the sealed end of the fluid container to the hollow body of the needle injector;
sterilizing the needle injector and the fluid container while the fluid container is attached to the injector;
depositing a medicinal fluid into the fluid container through the open end of the fluid container; and
closing the open end of the fluid container to enclose the medicinal fluid in the fluid container.
providing an injector housing having a generally open rearward end;
inserting a needle having a sharpened tip into the housing so that the needle is releasably held in a projecting position with the sharpened tip projecting forwardly from the housing;
providing a fluid container having a pierceable seal and a generally open end;
inserting the fluid container into the rearward open end of the housing;
filling the fluid container with fluid through the open end of the fluid container while at least a portion of the fluid container is disposed within the housing; and
sealing the open end of the fluid contained after the fluid container is filled.
10. The method of claim 9 wherein the step of sealing comprises attaching a fixed seal to the fluid container.

11. The method of claim 9 comprising the step of inserting a spring into the housing to bias the needle is shielded to prevent inadvertent contact with the needle after use.
12. The method of claim 11 comprising the step of providing a needle retainer operable to hold the needle against the bias of the spring, wherein the needle retainer is cooperable with the fluid container to cause retraction of the needle.
13. The method of claim 9 wherein of sealing comprises inserting a seal into the rearward open end of the fluid container.
14. The method of claim 13 comprising the step of fixing the axial position of the seal in the rearward open end of the fluid container to impede axial displacement of the fixed seal.
15. The method of claim 9 comprising the step of sterilizing the housing and fluid container together after the step of inserting the fluid container into the housing.
16. The method of claim 15 wherein the step of sterilizing occurs prior to the step of filling.
17. A method for producing a medical device, comprising the steps of:
providing an injector having a retractable needle;
attaching a fluid container to the injector;
sterilizing the injector and attached fluid container; and
filling the fluid container with a medicinal fluid.
18. The method of claim 17 comprising the step of sealing the fluid container with a seal after the step of filling, wherein the seal is fixed in position relative to the fluid container.

19. The method of claim 17 wherein the step of providing an injector comprises providing an injector that is cooperable with the fluid container to automatically retract the needle after use.
20. The method of claim 17 wherein the step of filling after the step of sterilizing.
21. A medical device, comprising:
a hollow housing having a generally open rearward end forming a socket;
a fluid container containing a quantity of medicinal fluid, the fluid container being adapted to engage the socket;
a needle having a sharpened tip, wherein the needle is displaceable between a projecting position in which the sharpened tip projects forwardly from the housing and a retracted position wherein the sharpened tip is enclosed within the housing;
a biasing element biasing the needle toward the retracted position;
a needle retainer operable between a retaining position in which the needle retainer releasably retains the needle in the projecting position against the bias of the biasing element and an release position in which the needle is released allowing the biasing element to displace the needle rearwardly;
a lock for locking the needle in the retracted position to impede displacement of the needle after the needle is displaced into the retracted position; and
a second lock for substantially permanently preventing separation of the fluid container from the housing;
wherein upon forward displacement of the fluid container, the fluid container engages the needle retainer displacing the needle retainer from the locked position to the unlocked position.
22. The device of claim 21, wherein the needle retainer comprises a latch

biased radially outwardly, releasably engaging the housing.

23. The device of claim 21 wherein the lock comprises a guide arm connected to the needle and biased radially outwardly from the needle into engagement with a channel in the interior wall of the housing, wherein the engagement between the guide arm and the channel substantially prevents rotational displacement of the needle retainer in the housing.
24. The device of claim 23, wherein the lock comprises a window in the wall of the housing, and the guide arm is configured to engage the window when the needle is displaced to the retracted position.
25. The device of claim 21 wherein the second lock permits displacement of the fluid container relative to the housing, while impeding separation of the fluid container from the housing.
26. The device of claim 21 wherein the second lock comprises a flange projecting radially inwardly into the socket of the housing.
27. The device of claim 21 wherein the second lock comprises a projection on the fluid container that projects radially outwardly.

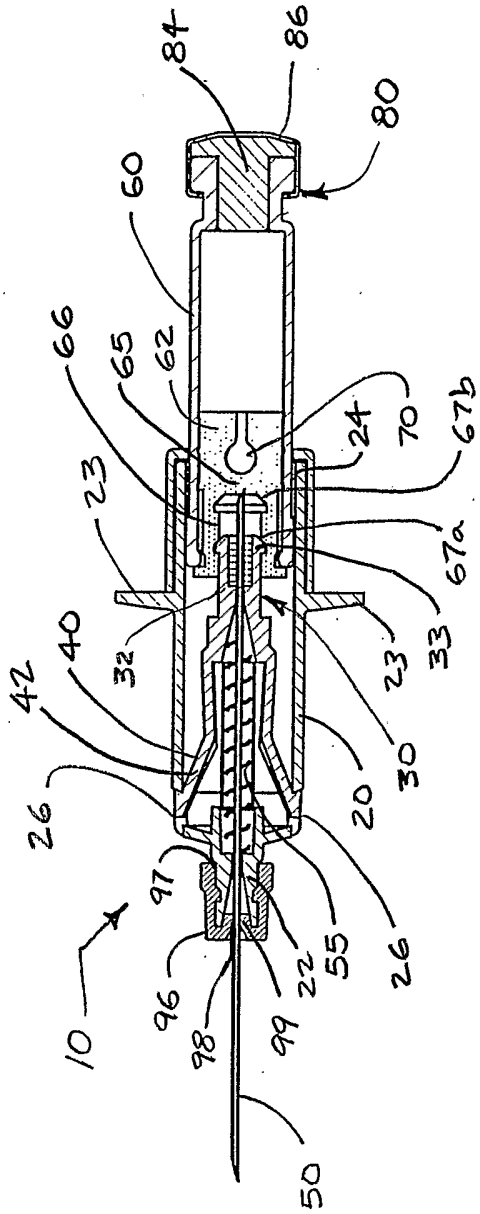

Figure 1

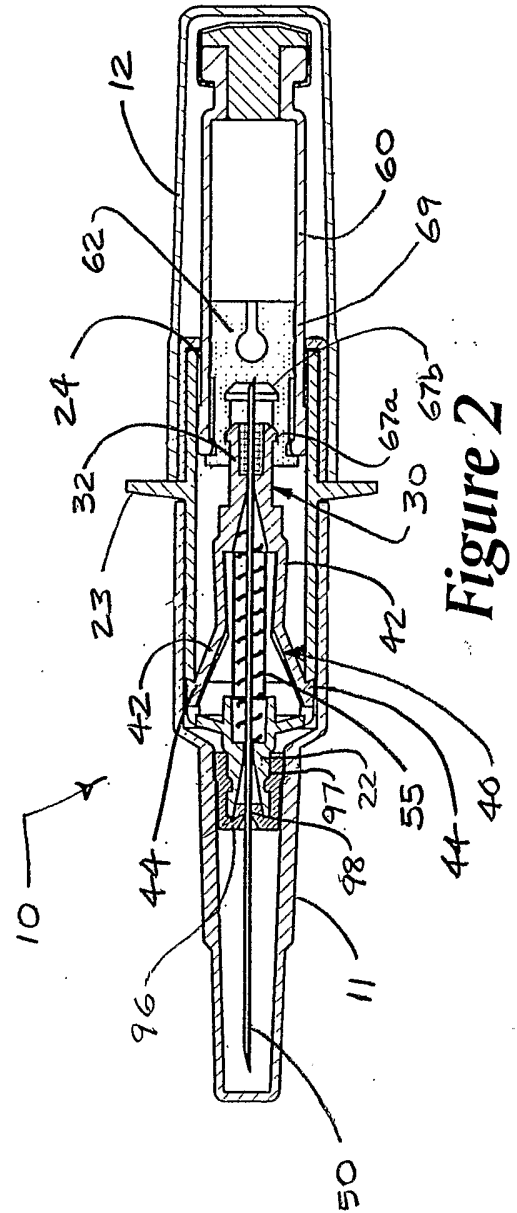

Figure 2

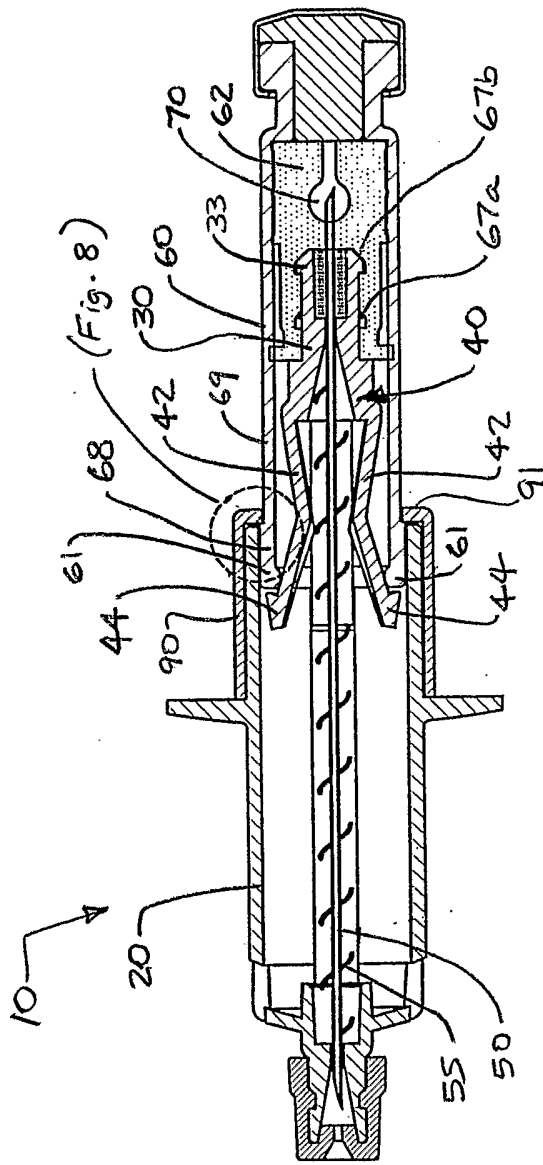

Figure 5

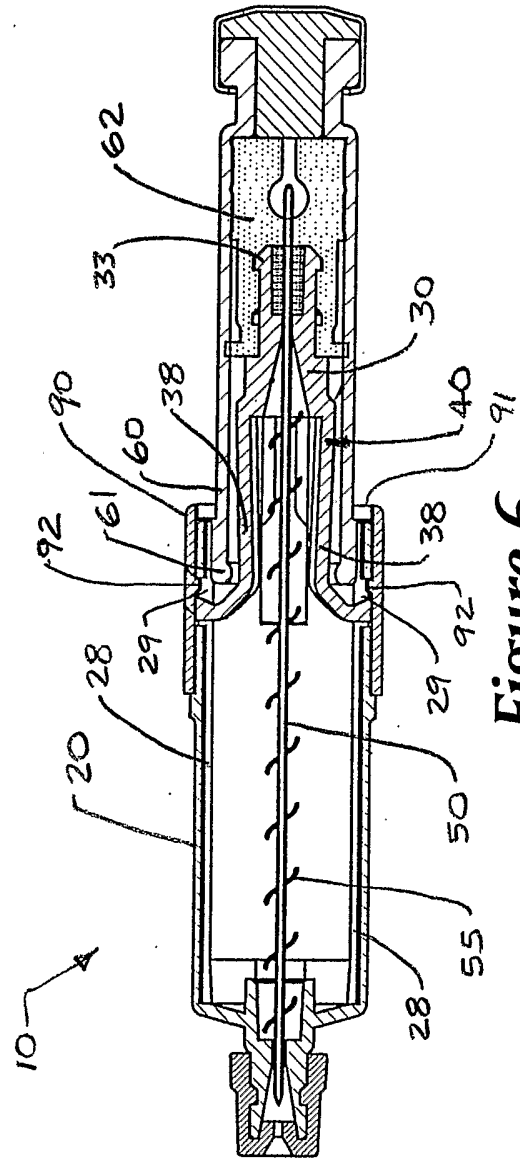

Figure 6

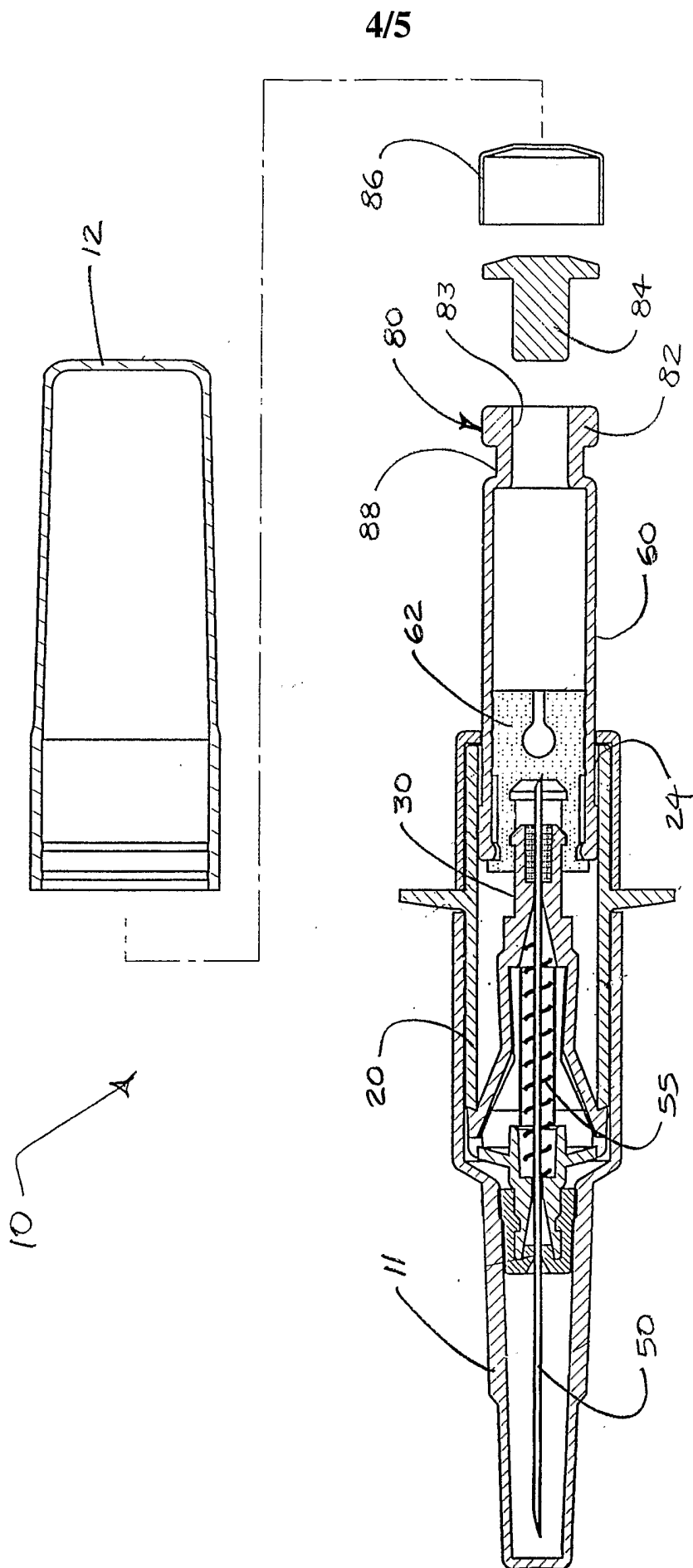

Figure 7

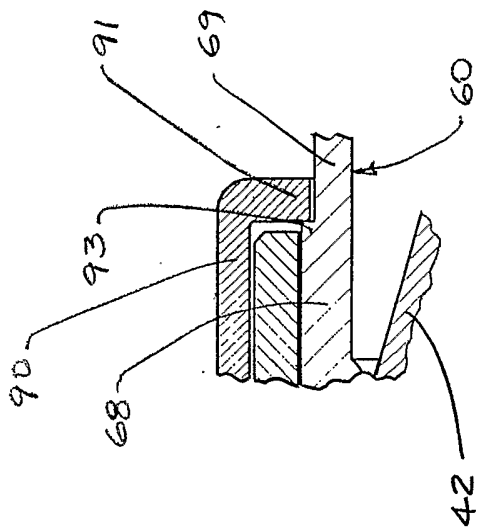

Figure 8