



US00D774109S

(12) **United States Design Patent** (10) **Patent No.:** **US D774,109 S**
Balan et al. (45) **Date of Patent:** **** Dec. 13, 2016**

(54) **TIP FOR A GROUND ENGAGING MACHINE IMPLEMENT**

Primary Examiner — Mark Goodwin
(74) *Attorney, Agent, or Firm* — Saidman DesignLaw Group, LLC

(71) Applicant: **Caterpillar Inc.**, Peoria, IL (US)

(72) Inventors: **Mihai Mircea Balan**, Dunlap, IL (US);
Douglas Serrurier, Morton, IL (US)

(57) **CLAIM**

The ornamental design for a tip for a ground engaging machine implement, as shown and described.

(73) Assignee: **Caterpillar Inc.**, Peoria, IL (US)

(**) Term: **15 Years**

DESCRIPTION

(21) Appl. No.: **29/536,027**

(22) Filed: **Aug. 12, 2015**

(51) **LOC (10) Cl.** **15-03**

(52) **U.S. Cl.**

USPC **D15/29**; D15/28

(58) **Field of Classification Search**

USPC D15/11, 28, 29; 37/456, 452, 450, 446,
37/454, 449, 453, 455, 903; 403/379.5,
DIG. 1; 111/152; 172/724, 730, 766, 770,
771, 721, 172/713, 699, 772

(Continued)

(56) **References Cited**

U.S. PATENT DOCUMENTS

1,220,186 A 3/1917 Chambers
1,384,701 A * 7/1921 McMonegal E02F 9/2825
37/454

(Continued)

FOREIGN PATENT DOCUMENTS

CL 2068-1995 10/1996
CL 391-1998 11/1998

(Continued)

OTHER PUBLICATIONS

Caterpillar Inc., Cat® K Series™ Tooth Systems, brochure (4 pages), 2006.

(Continued)

FIG. 1 is a front perspective view of a tip for a ground engaging machine implement showing our new design; FIG. 2 is a front view thereof; FIG. 3 is a rear view thereof; FIG. 4 is a left side view thereof; FIG. 5 is a right side view thereof; FIG. 6 is a top view thereof; FIG. 7 is a bottom view thereof; FIG. 8 is a front perspective view of a second embodiment thereof; FIG. 9 is a front view thereof; FIG. 10 is a rear view thereof; FIG. 11 is a left side view thereof; FIG. 12 is a right side view thereof; FIG. 13 is a top view thereof; FIG. 14 is a bottom view thereof; FIG. 15 is a front perspective view of a third embodiment thereof; FIG. 16 is a front view thereof; FIG. 17 is a rear view thereof; FIG. 18 is a left side view thereof; FIG. 19 is a right side view thereof; FIG. 20 is a top view thereof; and, FIG. 21 is a bottom view thereof.

The dashed broken lines represent structure or features which form no part of the claimed design; the broken lines themselves form no part of the claimed design. The line shading in FIGS. 1-21 represents contour.

1 Claim, 9 Drawing Sheets

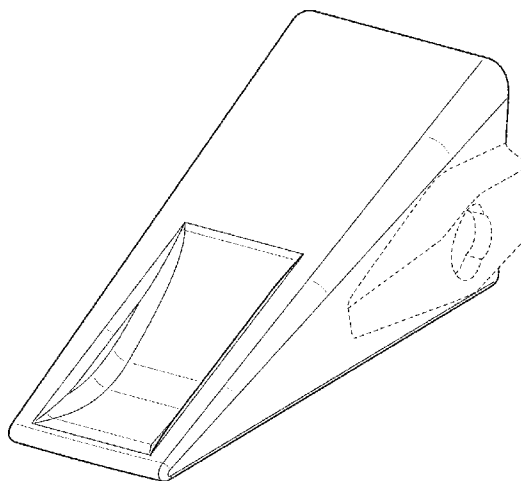

(58) **Field of Classification Search**
 CPC Y10T 29/49826; Y10T 403/589; Y10T
 403/7018; Y10T 403/7075; E02F
 9/28; E02F 9/2825; E02F 9/2833; E02F
 9/2866; E02F 9/2858; E02F 9/2808; E02F
 9/2841

See application file for complete search history.

(56) **References Cited**

U.S. PATENT DOCUMENTS

1,571,782 A 2/1926 Andrews
 1,856,930 A 5/1932 Robin
 2,256,488 A 9/1941 Murtaugh
 2,427,651 A 9/1947 Baer
 D182,143 S * 2/1958 Petersen 37/452
 2,982,035 A 5/1961 Stephenson
 3,019,537 A 2/1962 Stephenson
 3,079,710 A 3/1963 Larsen et al.
 3,312,004 A 4/1967 Johnson
 3,623,247 A 11/1971 Stepe
 3,774,324 A 11/1973 Lafond
 3,823,496 A 7/1974 Querci et al.
 3,832,077 A 8/1974 Von Mehren
 4,027,408 A 6/1977 Ramella et al.
 D251,431 S 3/1979 Klett et al.
 D252,461 S 7/1979 Korpi
 4,182,057 A 1/1980 Klett et al.
 D255,119 S 5/1980 Korpi
 4,231,173 A 11/1980 Davis
 D275,859 S 10/1984 Nilsson
 4,481,728 A 11/1984 Mulder et al.
 4,516,340 A 5/1985 Launder
 D296,442 S 6/1988 Broomhall
 4,761,900 A 8/1988 Emrich
 4,776,113 A 10/1988 Bedford et al.
 4,848,013 A 7/1989 Bowman et al.
 4,932,145 A 6/1990 Reeves
 4,949,481 A 8/1990 Fellner
 4,965,945 A 10/1990 Emrich
 4,980,980 A 1/1991 Schadov et al.
 5,018,283 A 5/1991 Fellner
 D336,476 S 6/1993 Garman
 D339,592 S 9/1993 Johansson
 D345,364 S 3/1994 Robinson
 D352,044 S 11/1994 Hahn
 5,423,138 A 6/1995 Livesay et al.
 D365,577 S 12/1995 Ruvang
 5,561,925 A 10/1996 Livesay
 D385,286 S 10/1997 Moreno
 5,709,043 A 1/1998 Jones et al.
 D391,583 S 3/1998 Moreno
 D392,292 S 3/1998 Moreno
 D395,661 S 6/1998 Moreno
 5,806,216 A 9/1998 Renski
 D399,511 S 10/1998 Launder et al.
 5,852,888 A 12/1998 Cornelius
 D408,422 S 4/1999 Moreno
 D410,657 S 6/1999 Launder et al.
 D413,338 S 8/1999 Pueyo Molina
 5,937,550 A 8/1999 Emrich
 D414,193 S 9/1999 Launder et al.
 D415,173 S 10/1999 Zaun
 5,983,534 A 11/1999 Robinson et al.
 D417,877 S 12/1999 Launder et al.
 D429,256 S 8/2000 Zaun
 D429,258 S 8/2000 Zaun
 6,321,471 B2 11/2001 Fernandez Muñoz et al.
 D454,891 S 3/2002 Ketting et al.
 D460,464 S 7/2002 Ketting et al.
 D461,198 S 8/2002 Ketting et al.
 D461,832 S 8/2002 Ketting et al.
 6,477,796 B1 11/2002 Cornelius
 6,735,890 B2 5/2004 Carpenter et al.
 6,745,503 B1 6/2004 Moreno et al.
 6,766,602 B2 7/2004 Cox et al.
 D499,749 S 12/2004 Launder et al.

6,836,983 B2 1/2005 Moreno et al.
 6,865,828 B1 3/2005 Molino et al.
 6,871,426 B2 * 3/2005 Keech E02F 9/2841
 37/456
 D505,137 S 5/2005 Steinlage et al.
 D512,078 S 11/2005 Poutre
 D527,029 S 8/2006 Launder et al.
 7,100,315 B2 9/2006 Carpenter et al.
 7,168,193 B2 1/2007 Moreno et al.
 D552,632 S 10/2007 De Martiis
 D560,232 S 1/2008 De Martiis
 7,367,144 B2 5/2008 Jones et al.
 D614,206 S 4/2010 Ruvang
 7,739,814 B2 6/2010 Carpenter et al.
 7,762,015 B2 7/2010 Smith et al.
 D624,943 S 10/2010 Gibbon
 D706,307 S 6/2014 Renski et al.
 D706,311 S 6/2014 Renski et al.
 D706,312 S 6/2014 Renski et al.
 D706,839 S 6/2014 Renski et al.
 D706,840 S 6/2014 Renski et al.
 D707,263 S 6/2014 Renski et al.
 D707,264 S 6/2014 Renski et al.
 8,943,717 B2 2/2015 Renski et al.
 D727,367 S 4/2015 Renski et al.
 D727,368 S 4/2015 Renski et al.
 D727,369 S 4/2015 Renski et al.
 D727,979 S 4/2015 Renski et al.
 D727,980 S * 4/2015 Renski D15/29
 D727,981 S 4/2015 Renski et al.
 D727,982 S 4/2015 Renski et al.
 D728,635 S 5/2015 Kunz
 D728,636 S 5/2015 Kunz
 D728,637 S 5/2015 Kunz
 9,062,436 B2 6/2015 Renski et al.
 D748,681 S * 2/2016 Renski D15/28
 D748,682 S * 2/2016 Renski D15/28
 D748,684 S * 2/2016 Renski D15/28
 D748,685 S * 2/2016 Kunz D15/28
 D749,146 S * 2/2016 Renski D15/28
 D749,147 S * 2/2016 Kunz D15/28
 D761,883 S * 7/2016 Kunz D15/28
 2004/0010949 A1 1/2004 Laguarda et al.
 2008/0028644 A1 2/2008 Almendros et al.
 2012/0131821 A1 * 5/2012 Brufau Guinovart . B2D 19/06
 37/452
 2012/0260540 A1 * 10/2012 Guimaraes E02F 9/2833
 37/453
 2012/0297649 A1 11/2012 Gomar
 2013/0086825 A1 4/2013 Renski et al.
 2013/0185964 A1 * 7/2013 Anisy E02F 9/2825
 37/453
 2013/0333254 A1 * 12/2013 Wallis E02F 9/2825
 37/456
 2014/0259806 A1 * 9/2014 Rimmey E02F 9/2891
 37/455
 2014/0259808 A1 * 9/2014 LaHood E02F 9/2841
 37/455
 2015/0167278 A1 * 6/2015 Rivera E02F 9/2875
 37/452

FOREIGN PATENT DOCUMENTS

CL 1193-1999 9/1999
 CL 223-1999 11/1999
 CL 1457-1999 11/1999
 CL 1583-1999 6/2000
 CL 2671-2005 7/2006
 CL 3115-2005 9/2006
 CL 3116-2005 9/2006
 CL 173-2008 8/2008
 CL 174-2008 8/2008
 CL 2524-2008 1/2009
 CL 1764-2008 7/2009
 CL 618-2010 11/2010
 CL 739-2010 12/2010
 CL 291-2012 11/2012
 EM 000089099-0001-0003 10/2003

(56)

References Cited

FOREIGN PATENT DOCUMENTS

EM 000877477-0001-0009	1/2008
EM 000895396-0001-0015	3/2008
EP 0 411 486 A1	2/1991
EP 2 011 927 A2	1/2009
GB 1049195	3/1988
GB 1050103	4/1988
GB 2010025	4/1990
GB 2010026	4/1990
GB 2057051	12/1995
GB 2057052	12/1995
GB 2057053	12/1995
GB 2060104	4/1996
GB 2060105	4/1996
GB 2057055	5/1996
GB 2091441	10/1999
GB 2091502	10/1999
GB 2095654	3/2000
GB 2097590	3/2000
GB 2097591	4/2000
GB 2097592	4/2000

GB	2097593	5/2000
GB	2104929	3/2001
GB	2106421	4/2001

OTHER PUBLICATIONS

Caterpillar Inc., "Cat Backhoe Loader Options," published Jan. 1, 2005.

U.S. Appl. No. 29/524,183, filed Apr. 17, 2015. (Unpublished).

U.S. Appl. No. 29/536,033, filed Aug. 12, 2015. (Unpublished).

U.S. Appl. No. 29/536,022, filed Aug. 12, 2015. (Unpublished).

U.S. Appl. No. 29/536,024, filed Aug. 12, 2015. (Unpublished).

U.S. Appl. No. 29/536,032, filed Aug. 12, 2015. (Unpublished).

U.S. Appl. No. 29/536,030, filed Aug. 12, 2015. (Unpublished).

U.S. Appl. No. 29/536,019, filed Aug. 12, 2015. (Unpublished).

U.S. Appl. No. 29/536,036, filed Aug. 12, 2015. (Unpublished).

U.S. Appl. No. 29/536,035, filed Aug. 12, 2015. (Unpublished).

U.S. Appl. No. 29/536,029, filed Aug. 12, 2015. (Unpublished).

U.S. Appl. No. 29/536,026, filed Aug. 12, 2015. (Unpublished).

U.S. Appl. No. 29/536,034, filed Aug. 12, 2015. (Unpublished).

U.S. Appl. No. 14/824,655, filed Aug. 12, 2015. (Unpublished).

U.S. Appl. No. 14/824,749, filed Aug. 12, 2015. (Unpublished).

* cited by examiner

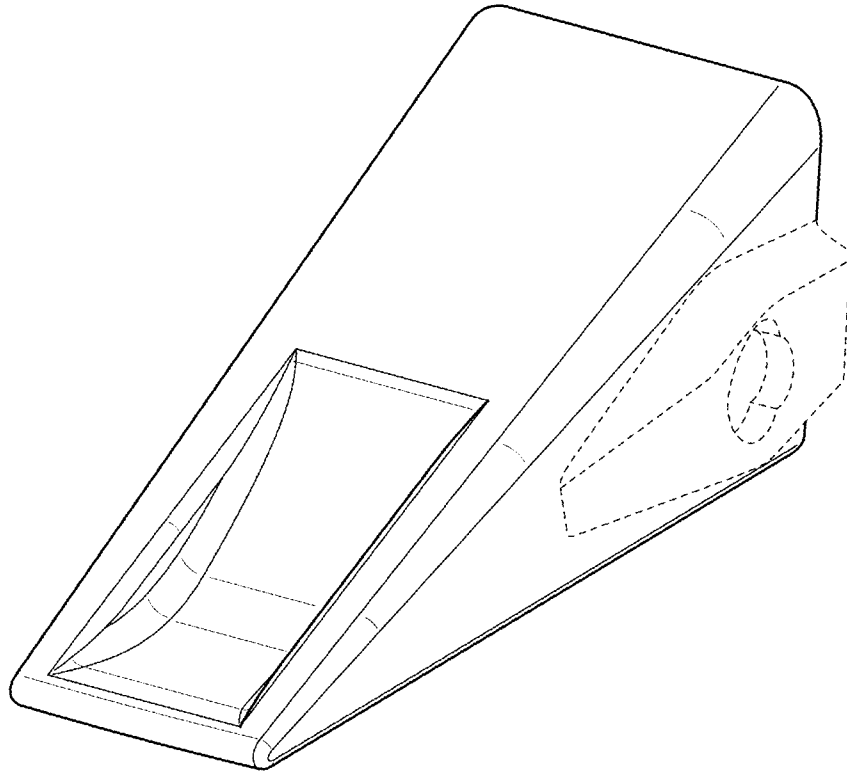

FIG. 1

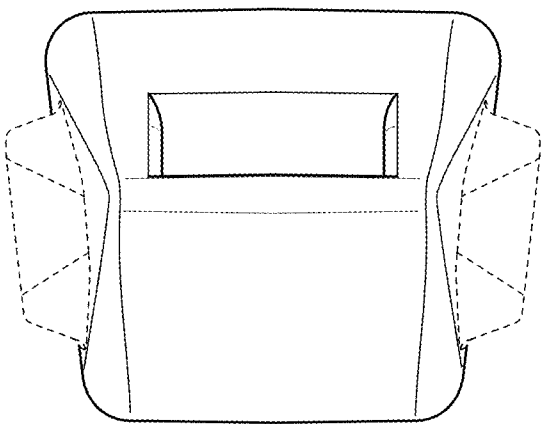

FIG. 2

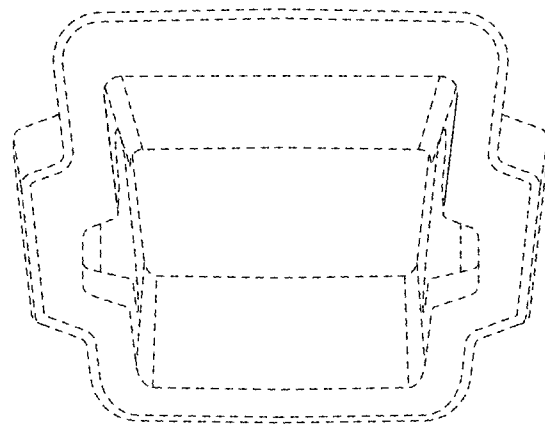

FIG. 3

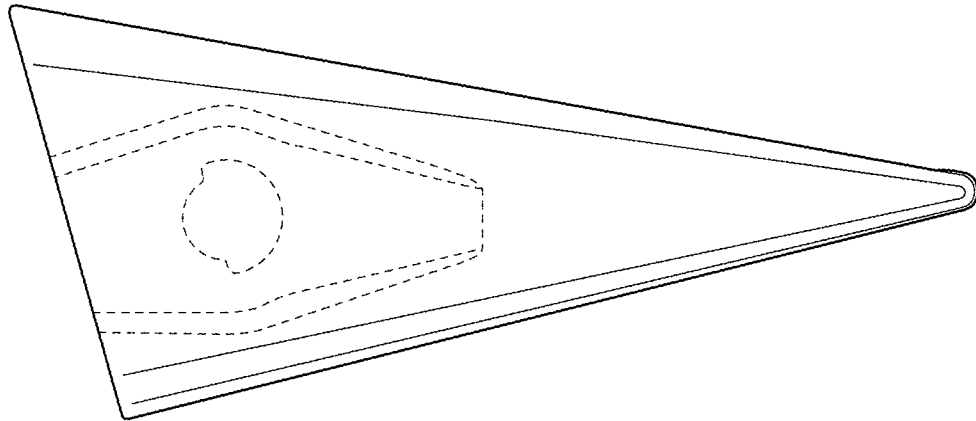

FIG. 4

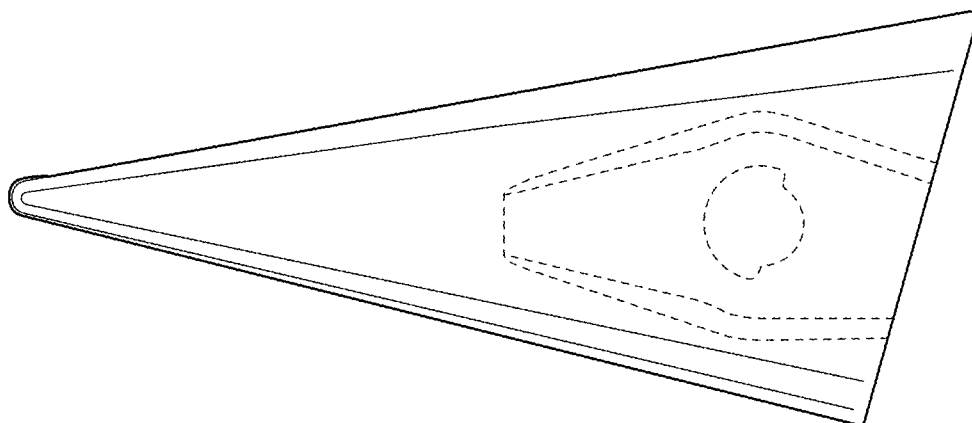

FIG. 5

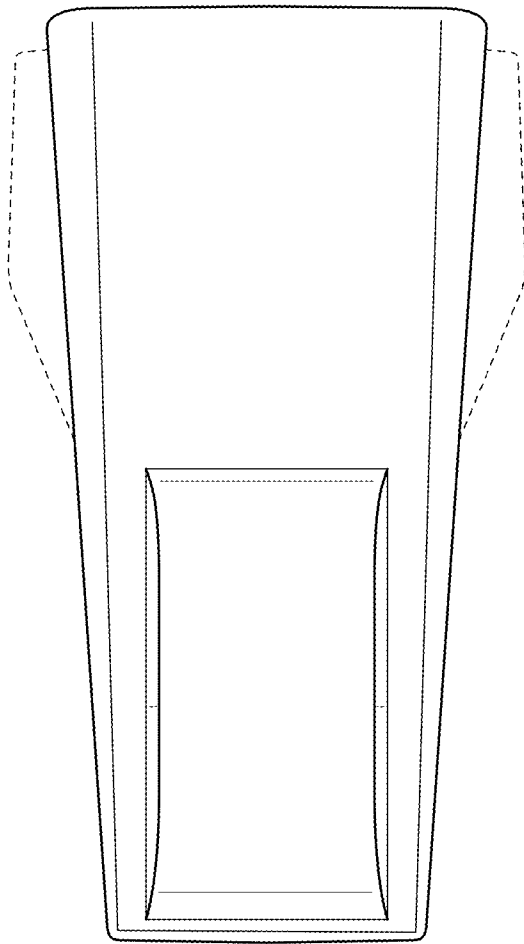

FIG. 6

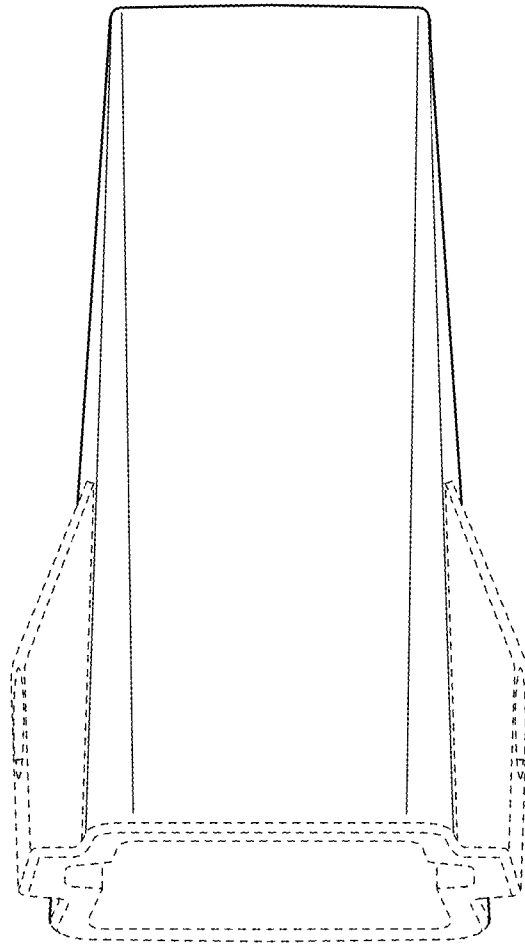

FIG. 7

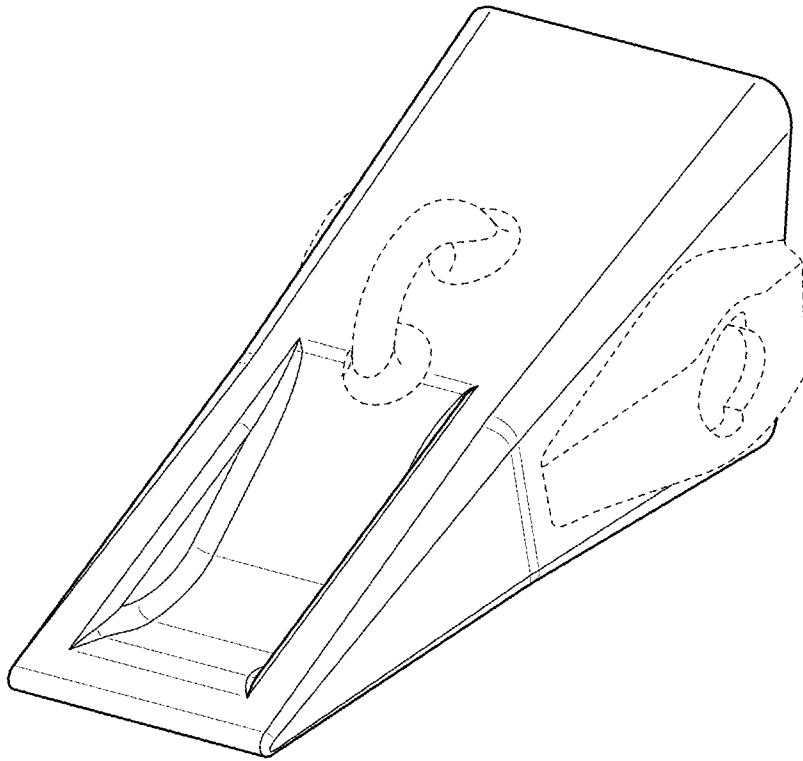

FIG. 8

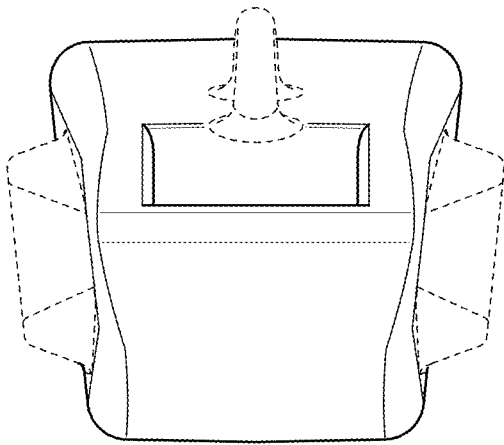

FIG. 9

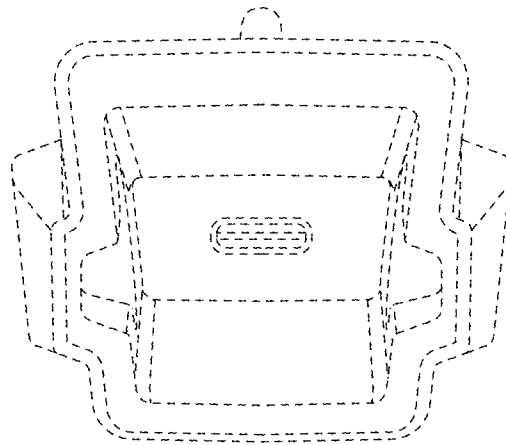

FIG. 10

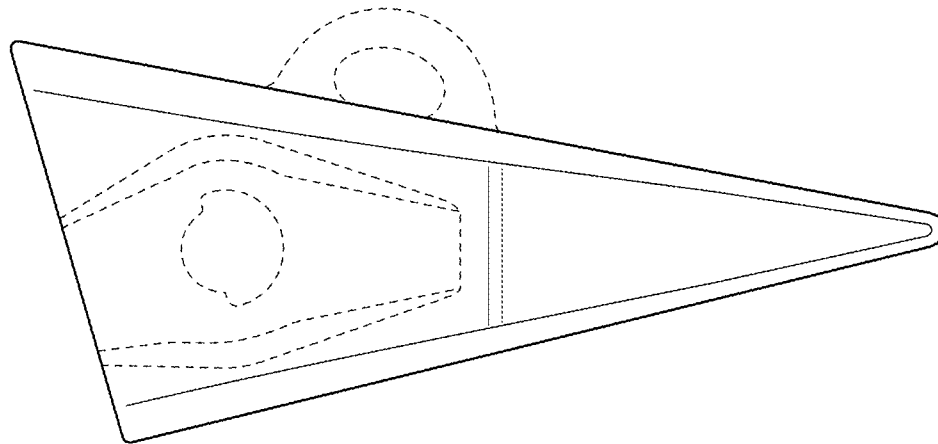

FIG. 11

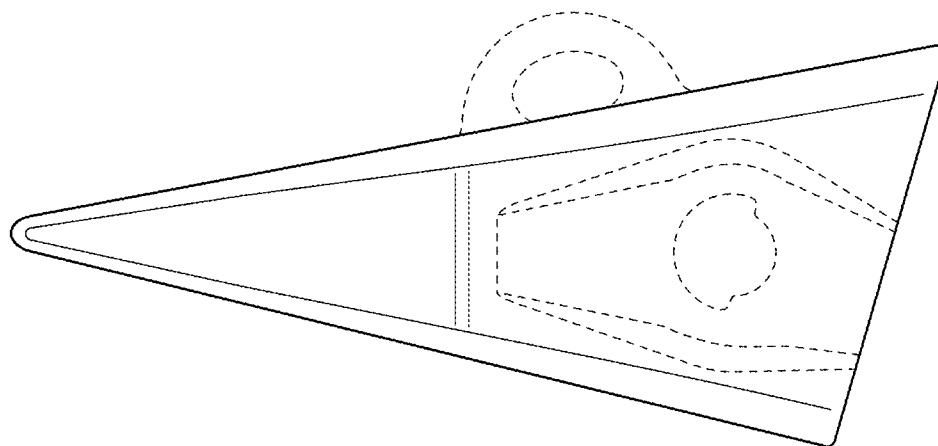

FIG. 12

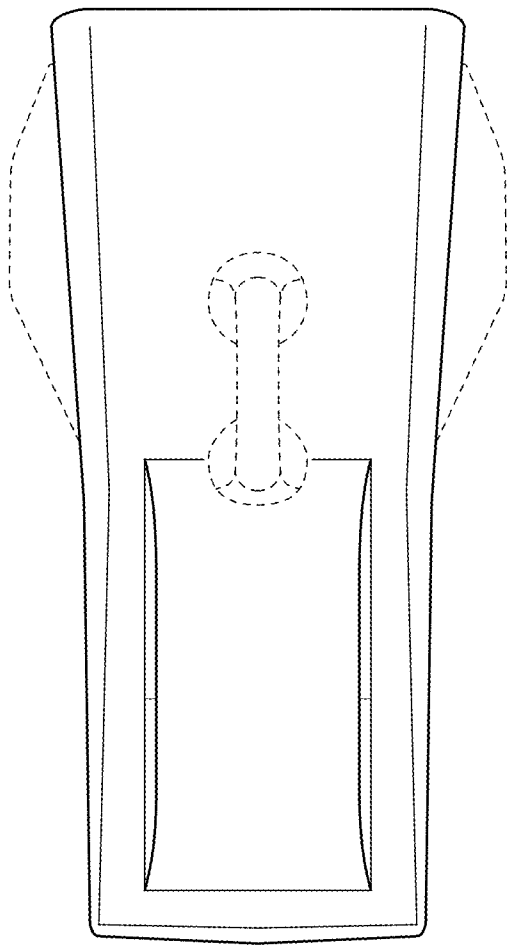

FIG. 13

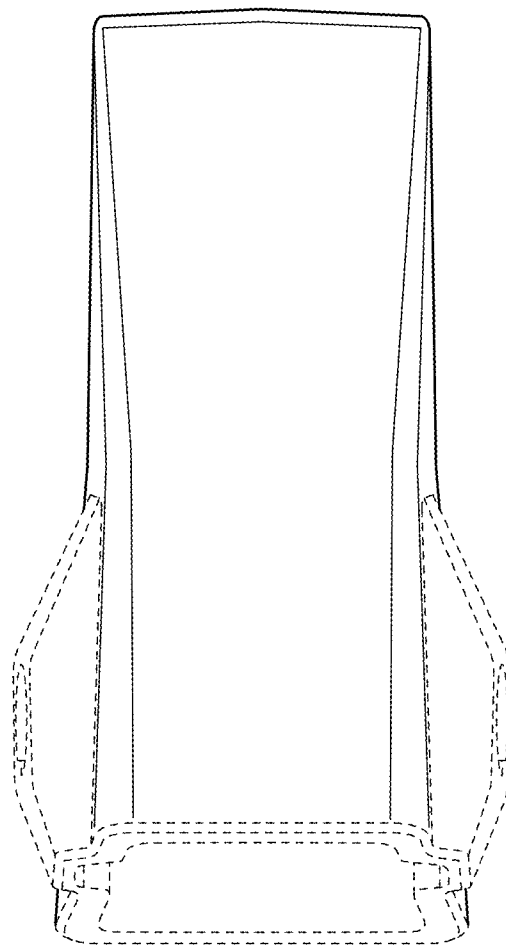

FIG. 14

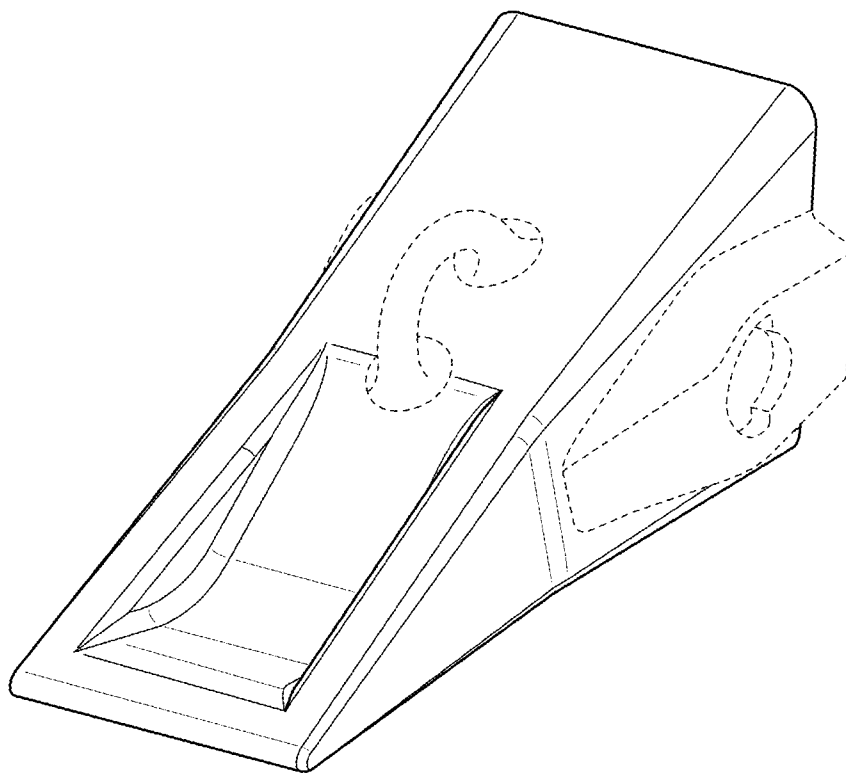

FIG. 15

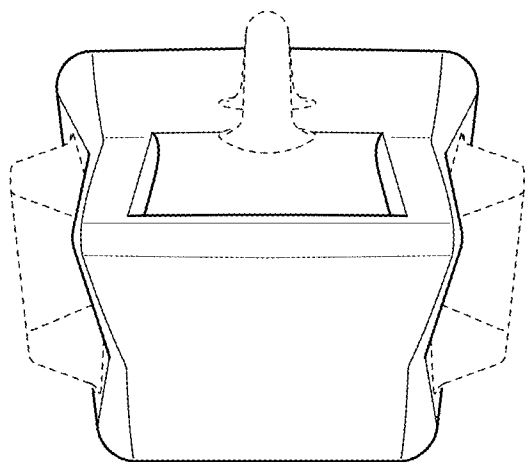

FIG. 16

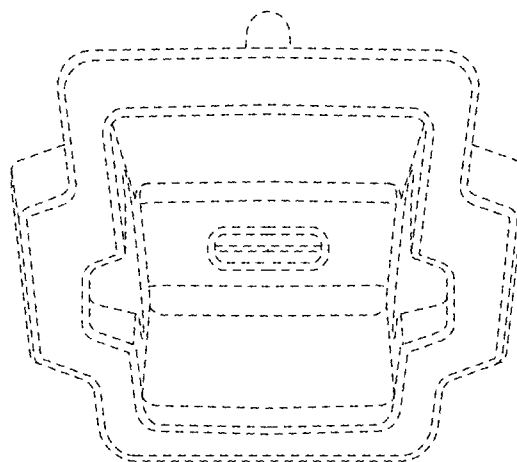

FIG. 17

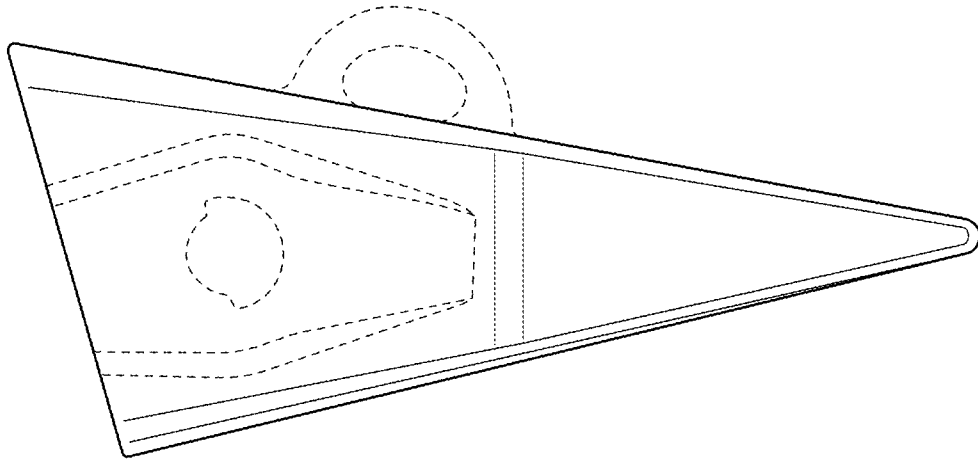

FIG. 18

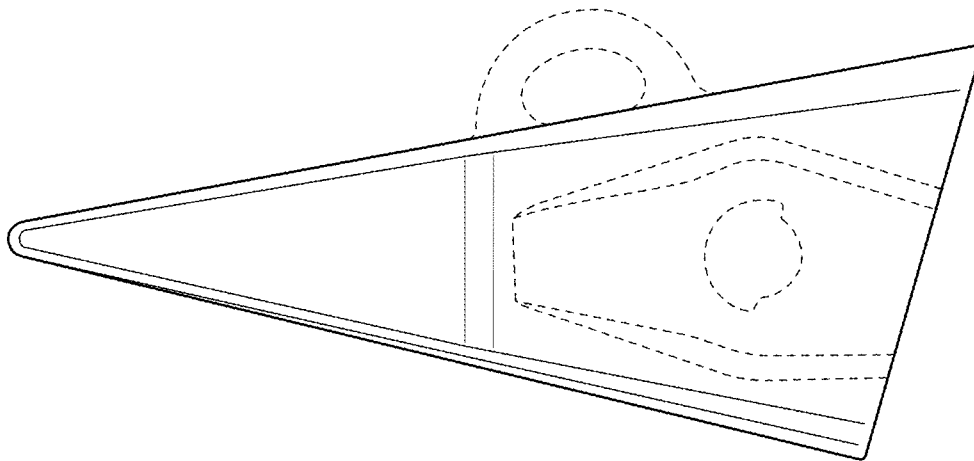

FIG. 19

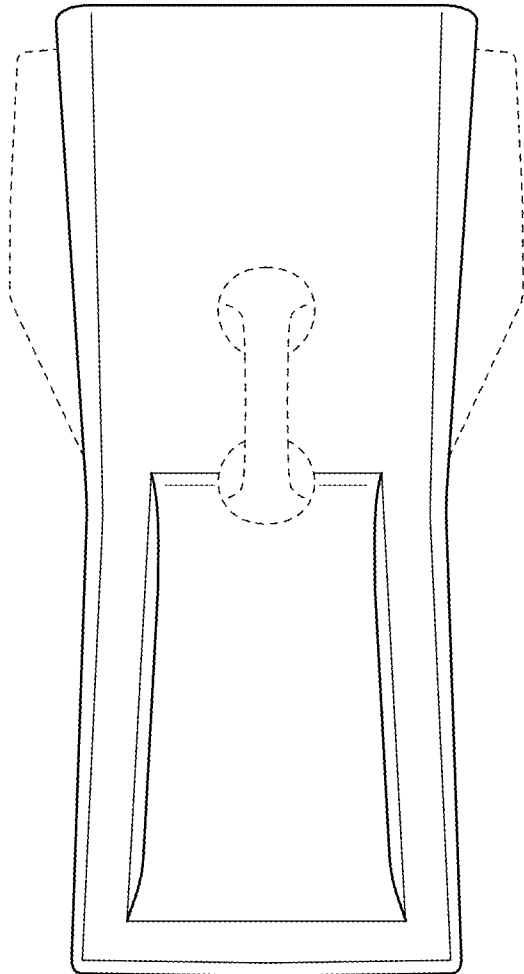

FIG. 20

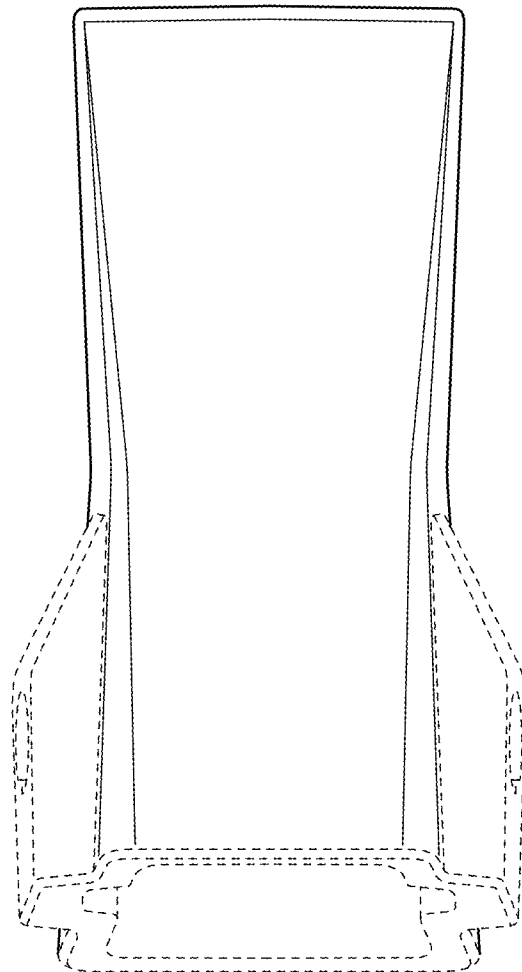

FIG. 21