

- (21) Application No **8322708**
- (22) Date of filing **24 Aug 1983**
- (30) Priority data
- (31) **8204865**
- (32) **25 Aug 1982**
- (33) **Sweden (SE)**
- (43) Application published
4 Apr 1984
- (51) **INT CL³**
G01G 19/02
- (52) Domestic classification
G1W F
- (56) Documents cited
GB A 2110394
GB A 2076977
GB A 2054874
GB A 2042742
- (58) Field of search
G1W
- (71) Applicants
Flintab Vagsystem AB,
(Sweden),
Bultvagen 5,
S-552 71 Jonkoping,
Sweden.
- (72) Inventors
Nils Ahl

(74) Agent and/or Address for Service
Kilburn & Strode,
30 John Street,
London WC1N 2DD.

(54) **Weighbridges**

(57) Weighing apparatus for weighing vehicles (2) comprises a load platform made in adjoined sections (4,6,8) each supported by brackets (30,32,34,36,40,42,44,46) which project into gaps (38,48) between opposed ends of adjacent platform sections (4,6 or 6,8) or into gaps (57) between the end of a platform section (4,8) and the end portions of the foundation structure (28). The brackets rest on load-sensing units (10,12,14,16,18,20,22,24) which are accessible for maintenance in the gaps. Each unit can be removed without substantial movement of the platform sections (4,6,8), by inserting a lifting jack into the gap and lifting the platform sections. The platform sections (4,6,8) may be made of concrete, and have their supporting brackets (30 to 46) asymmetrically arranged so that the platform sections are interchangeable.

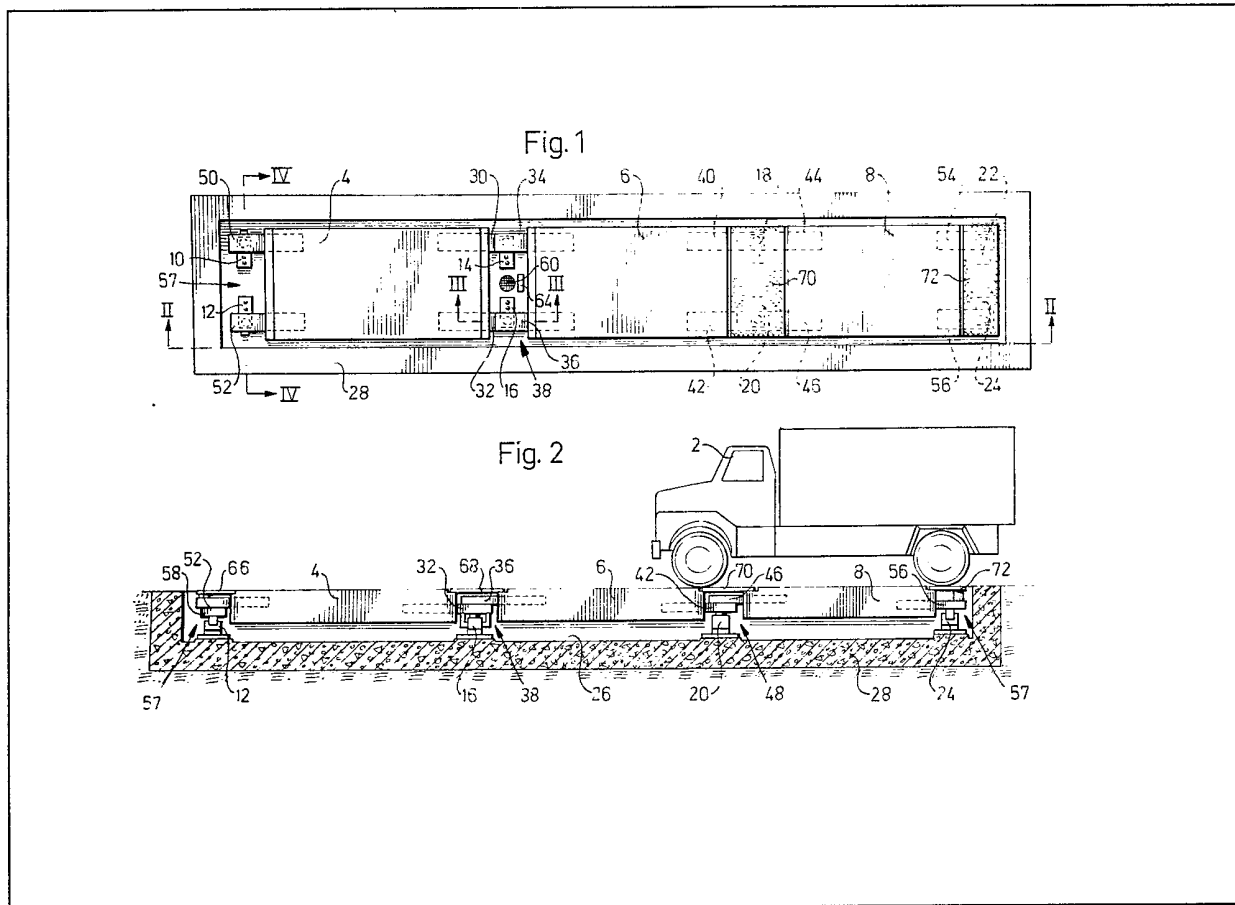

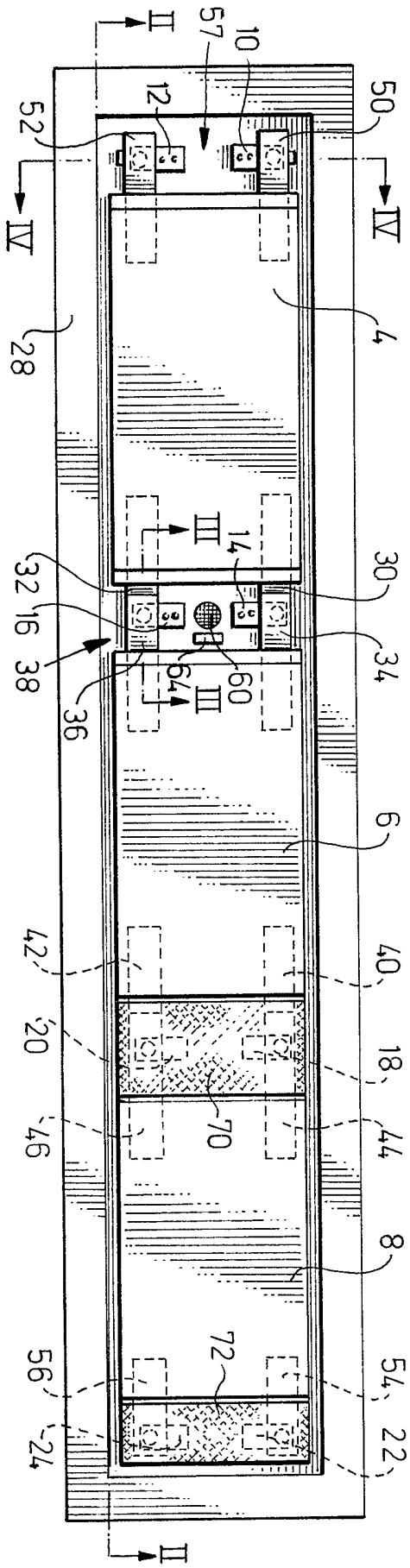

Fig. 1

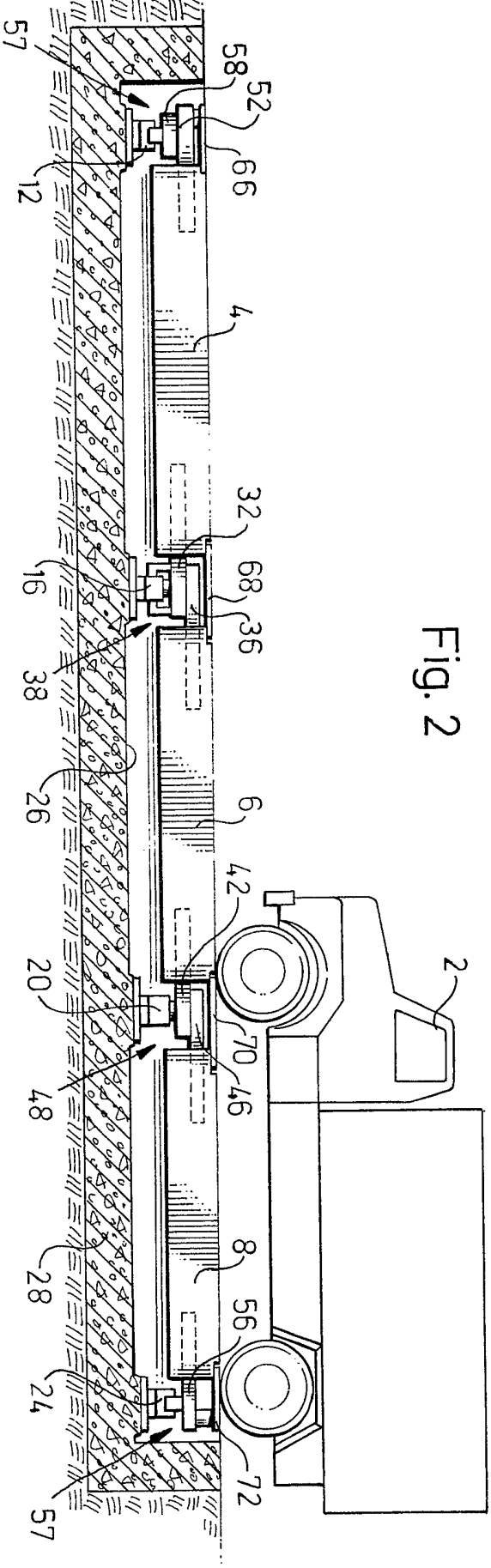

Fig. 2

Fig. 3

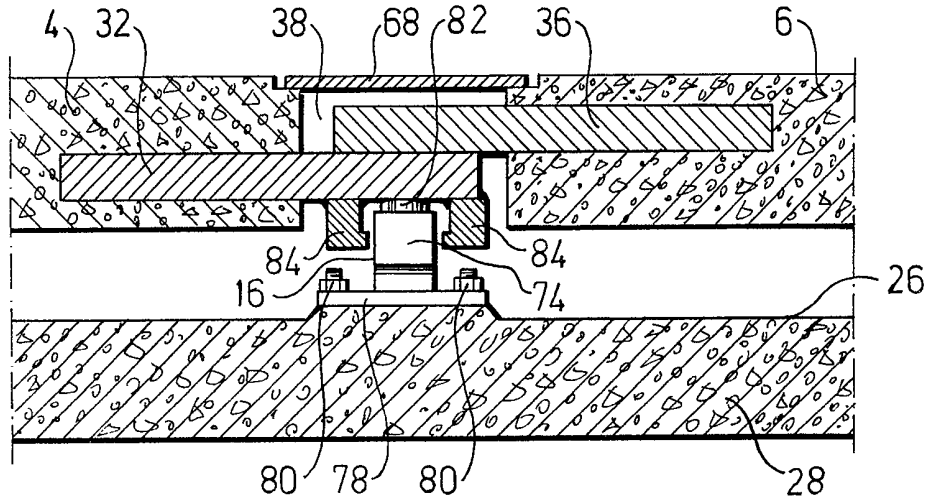
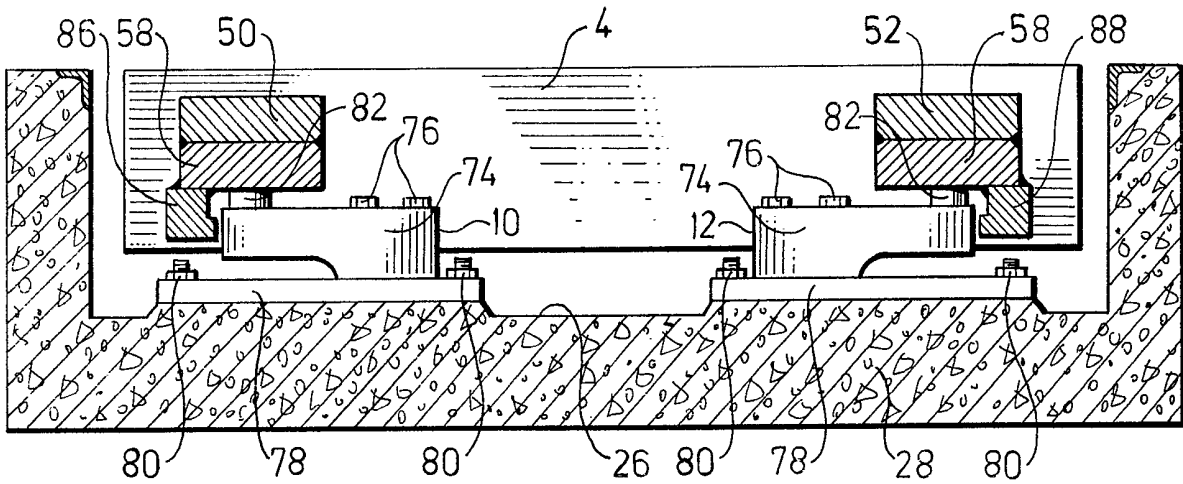

Fig. 4



SPECIFICATION

Weighing apparatus

- 5 This invention relates to weighing apparatus of the type comprising a platform intended to carry a load to be weighed, e.g. a vehicle, the platform comprising at least one platform member supported by means of load-sensing units on a rigid fixed support.
- 10 Such apparatus, which is sometimes called a weigh-bridge, is referred to herein as being of the type specified.

Weighing apparatus of the type specified is described in the prior art, e.g. in Swedish Patent

- 15 Application No. 805-115-4 and in U.S. Patent Specifications Nos. 2,962,275 and 3,447,618. In many cases of weighing apparatus of this type the platform is composed of one or more bridge sections, referred to herein as platform members, which are respectively supported by load-sensing units, at least one of which is mounted in conjunction with a marginal portion of the respective platform member, for example load-sensing units at opposite edges of a platform member. Common as to many weighing
- 20 apparatus of this type is that at least the load-sensing units that are applied in connection with opposite marginal portions of the platform members are so arranged that they are comparatively inaccessible for maintenance, repair and exchange. More specifically, it is usually necessary for this purpose to lift the platform members substantially completely away from the support surface which carries the platform. Since the platform members are very heavy, heavy lifting equipment is thus required, and
- 30 such equipment is not normally available in the vicinity of the weighing apparatus.

One object of the present invention is to provide a weighing apparatus of the type specified in which the load-sensing units are considerably more easily accessible than in previous weighing apparatus. This object has been achieved by the weighing apparatus in accordance with the invention in that the platform member and said at least one load-sensing unit are adapted such that the unit is easily accessible for maintenance or removal without substantial movement of the (or any) platform member. By the expression "substantial movement" is meant complete removal from the support surface of an entire platform member or the complete weighing apparatus.

- 50 Thus, the load-sensing units will thus be easily accessible without any substantial movement of the platform members being required. To enable the removal of a load-sensing unit it is here preferably intended that the weighing apparatus shall be constructed and arranged such that only a part of the apparatus in the immediate vicinity of this unit need be lifted, and only sufficiently that the unit will be just free of the respective platform members. Preferably, the lift should be possible with a simple, easily available lifting means such as a jack.

Thus in one form of the invention, a said accessible load-sensing unit may be situated in an easily accessible gap between the associated platform member and adjacent structure, e.g. a gap between

- adjacent edges of two adjacent platform members or a gap between an edge of the associated platform member and an end portion of the weighing apparatus. Each such gap may be dimensioned to allow the insertion of a lifting device such as the jack referred to, for the purpose of lifting the respective platform member(s) just sufficiently from the load-sensing unit to allow the removal of the latter.

- The invention and its advantages may be carried into practice in various ways, but one specific embodiment thereof will now be described in detail by way of example only and with the accompanying drawings, wherein:

- Figures 1 and 2* schematically illustrate a weighing apparatus embodying the invention, respectively in plan view and in longitudinal section on the line II-II in Figure 1; and

- Figures 3 and 4* are detail views in section on the lines III-III and IV-IV respectively in Figure 1, and on a larger scale, and illustrate in more detail the arrangements in connection with the load-sensing units.

- The weighing apparatus illustrated in the drawings includes a platform intended to support a load, represented at 2 in the shape of a vehicle. The platform includes three elongate rectangular platform members 4,6,8 arranged end-to-end, and eight load-sensing units 10,12,14,16,18,20,22, 24. The platform members 4,6,8 are carried on a support surface 26 via these load-sensing units, the surface 26 being the upper surface of a recessed concrete foundation 28 at the weighing site. The load-sensing units 10 and 12 are each situated in conjunction with a corner of the free end of the platform member 4, while units 22 and 24 are each situated in conjunction to a corner of the free end of the platform member 8. Units 14 and 16 are situated in conjunction with the mutually opposing edge portions of the platform members 4 and 6, while units 18 and 20 are situated in conjunction with the mutually opposing edge portions of the platform members 6 and 8.

- In accordance with an important distinguishing feature of the invention, the members 4,6 and 8 together with the units 10,12,14,16,18,20,22, 24 are arranged such that the latter are easily accessible for maintenance and removal without substantial movement of the platform members. This will be described in greater detail below.

- The platform members 4 and 6 are carried by the load-sensing units 14,16 via brackets in the form of steel flats 30,32 and 34,36 attached to the members. These brackets extend into a space in the form of a wide gap 38 in which the units 14 and 16 are arranged, the gap being situated between the mutually opposing edge sections of the platform members 4 and 6. In the gap 38 the flat 30 rests on the load-sensing unit 14 and the flat 34 rests on, and is attached to, the flat 30. In the same way, the flat 36 rests on, and is attached to the flat 32, which in turn is carried by the unit 16. Welded joints are used and have been indicated in the Figures as an example of the attachment between flats 30 and 34 and between flats 32 and 36.

- In the same way, the platform members 6 and 8 are carried by the load-sensing units 18 and 20 with the aid of brackets in the form of steel flats

40,42,44,46 attached to these members. These flats extend into a space in the form of a wide gap 48 in which the load-sensing units 18 and 20 are arranged, the gap being situated between the platform members 6 and 8.

At their free ends the platform members 4 and 8 are carried by the load-sensing units 10,12 and 22,24 via brackets in the form of steel flats 50,52 and 54,56 attached to the members 4 and 8, said flats extending into the space 57 at the respective end edges of the concrete foundation.

The platform members 4,6,8 are alike, and the brackets are asymmetrically situated such that the members are essentially optionally interchangeable. More specifically, the brackets 50,52 on one side and 30,32 on the other side of the platform member 4 are displaced in height relative each other. The same applied to the brackets 34,36 and 40,42 for the member 6, and brackets 44,46 and 54,56 for the member 8. The displacement in height is such that the upper sides of the platform members are situated in the same horizontal plane when the brackets 34,36,44,46 rest on the respective brackets 30,32,40,42. The brackets 50,52 at the free end of the platform member 4 rest on the load-sensing units 10 and 12 via spacer pads 58, which are welded to the brackets 50,52 and are equally as thick as the brackets 30,32,40,42. At the free end of the member 8 the brackets 54 and 56 rest directly on the load-sensing units 22 and 24.

As will be apparent from the above, the load-sensing units 10,12,14,16,18,20,22 and 24 are situated in the gaps 38,48 and 57, and are easily accessible from the outside. These gaps permit the insertion of a lifting means, e.g. a jack, under the platform members or the brackets. Accordingly, if it is desired to remove the unit 14 for exchange or service, a jack is introduced sideways into the gap 38 and is placed under the platform member 4, or the bracket 30. The lift is then made just sufficient for removing the unit 14 sideways from the space between the bracket 30 and support surface 26 after release from the latter. This lift can be so small that the platform members continue substantially to rest on the other load-sensing units, due to the fact that the platform arrangement can deflect somewhat.

The spaces between the platform members and at their free ends also allow using the spaces for locating summing or integrating boxes and cables for the load-sensing units, and junction boxes and cables for possible electrical heating. Similarly, drains are placed accessible for cleaning from above through the spaces 38,48. In Figure 1 there is thus indicated a drain at 60 and a summing box at 64.

The gaps 38 and 48 and the space 57 between the free ends of the members 4 and 8 and the respective edge section of the foundation 28 are covered by plates 66,68,70,72, of which the first two are omitted in Figure 1.

The load-sensing units may preferably contain shear-force-sensing load cells of the type described in the US Patent 3 960 228, for example. In Figures 3 and 4, the load cells for the respective load-sensing units 16,10 and 12 have all been given the same reference denotation 74, each cell 74 being attached

to a plate 78 by bolts 76, the plate in turn being attached to the support surface 26 by bolts 80.

The load is transferred to the load cell via a loading element 82, such that the respective bracket rests on the corresponding loading element. Accordingly, for the load-sensing units 10 and 12 the flats 50 and 52 rest on the associated loading elements 82 via the spacer pads 58, and for the load-sensing unit 16 the flats 32,36 rest on the loading element 82. The loading element 82 may conventionally consist of gliding or pivoting pins.

To keep the bridge formed by the members 4,6,8 in place longitudinally, the flat 32 has welded to its underside two stops 84 extending along either side of the load cell 74, with some play relative thereto.

To keep the bridge in place laterally, the spacer pads 58 at the units 10 and 12 have welded stops 85 and 88, respectively, each stop extending with some play along the free end of the corresponding load cell. A corresponding lateral support arrangement is also provided for the units 22 and 24 at the other end of the bridge. However, the corresponding lateral stops are, of course attached directly to the flats 54 and 56.

The load-sensing unit with a load cell of the type mentioned hereinbefore and the arrangement for keeping the bridge in place is no part of the present invention and therefore does not need to be described in detail here. Further details will be apparent from the US Patent 3 960 228, as well as the Swedish Patent Applications 7608324-5 and 8005115-4. The electronic arrangement for weighing is also described in said publication.

Apart from the advantages apparent from what has already been described, it is particularly worthwhile emphasizing that the platform members can to advantage be produced in concrete, e.g. pre-stressed or post-stressed concrete. Steel bridges (platform members) have the advantage over concrete bridges that they are lighter, and can therefore be more easily moved from the support surface of the weighing apparatus if it is necessary to get access to the load-sensing units for maintenance or exchange. On the other hand, concrete bridges are cheaper to produce and less sensitive to corrosion than steel bridges. When, by means of the invention, the need for substantial movement of the platform members is no longer necessary, for such purposes the use of concrete has practically no disadvantage from the weight aspect.

The invention is naturally not limited to the embodiment illustrated on the drawings. It is also applicable to a platform consisting of only one or two, or even more than three platform members. Instead of a recessed arrangement of the weighing apparatus, an embodiment with it placed on flat ground with approach and departure ramps may also be used. Although the particular arrangement of the load-sensing units apparent from Figures 1 and 2 is particularly advantageous, due, inter alia, to the number of such units being kept at a minimum, it is also conceivable to use a number other than two load-sensing units in each of the gaps between the platform members. The load-sensing units could also be of some other kind than those described with

reference to Figures 3 and 4.

CLAIMS

- 5 1. Weighing apparatus of the type specified,
which is so constructed and arranged that at least
one of the load-sensing units mounted in conjunc-
tion with a marginal portion of a platform member is
easily accessible for maintenance or removal with-
10 out substantial movement of a platform member.
2. Weighing apparatus as claimed in Claim 1, in
which a said accessible load-sensing unit is situated
in an easily-accessible gap between the associated
platform member and adjacent structure.
- 15 3. Weighing apparatus as claimed in Claim 2, in
which a said accessible load-sensing unit is situated
in a gap between adjacent edges of two adjacent
platform members.
4. Weighing apparatus as claimed in Claim 2, in
20 which a said accessible load-sensing unit is situated
in a gap between an edge of the associated platform
member and an end portion of the weighing appar-
atus.
5. Weighing apparatus as claimed in any one of
25 Claims 2 to 4, in which the said gap is dimensioned
to allow the insertion of a lifting device for the
purpose of lifting the respective platform member(s)
just sufficiently from the load-sensing unit to allow
the removal of the latter.
- 30 6. Weighing apparatus as claimed in any one of
Claims 2 to 5, in which the said associated platform
member has attached to it a bracket which extends
into the gap and rests on the said accessible
load-sensing unit.
- 35 7. Weighing apparatus as claimed in Claim 6
having a plurality of platform members each with a
plurality of the said brackets which project into
respective gaps and support the platform members
on load-sensing units situated in the gaps, the
40 brackets of each platform member being asymmet-
rically arranged in such a manner that the platform
members are interchangeable.
8. Weighing apparatus as claimed in Claim 7, in
which in each gap between adjacent platform mem-
45 bers each said accessible load-sensing unit supports
two brackets, one attached to each of the adjacent
platform members.
9. Weighing apparatus as claimed in Claim 8, in
which the two brackets supported by each said
50 load-sensing element are at different levels, one
bracket resting on the other.
10. Weighing apparatus as claimed in any one of
the preceding claims, in which the platform mem-
bers are made of concrete, for example pre-stressed
55 or post-stressed concrete.
11. Weighing apparatus substantially as specific-
ally described herein with reference to the accom-
panying drawings.