

[54] **DIMMER UNIT FOR A LIGHTING CONTROL SYSTEM**

[75] Inventor: **Benjamin F. Gilbreath**, Richardson, Tex.

[73] Assignee: **Hunt Electronics Company**, Dallas, Tex.

[22] Filed: **Aug. 2, 1971**

[21] Appl. No.: **168,317**

[52] U.S. Cl.**315/291, 315/315, 323/3**

[51] Int. Cl.**H05b 39/02**

[58] Field of Search.....**315/201, 202, 291-295, 315/312-317**

[56] **References Cited**

UNITED STATES PATENTS

2,920,240	1/1960	Macklem.....	315/312 X
3,585,444	6/1971	Crowley.....	315/202
3,534,224	10/1970	Skirpan et al.....	315/292 X
3,579,030	5/1971	Bentham.....	315/291

Primary Examiner—**Alfred L. Brody**
 Attorney—**Giles C. Clegg, Jr. et al.**

[57] **ABSTRACT**

A plurality of dimmer units are connected between an alternating-current power source and different ones of a plurality of lamp loads for separately controlling the flow of alternating current through such lamp leads. Each dimmer unit includes a switching mechanism for passing the alternating current to the lamp load and a controllable direct-current responsive timing mechanism for controlling the fraction of each alternating-current half cycle during which the switching mechanism is conductive. The direct-current control signal input terminals of each dimmer unit are connected between corresponding output terminals of a pair of multiple output pre-set control units. A fader control unit supplies direct-current voltages to the pre-set control units and includes means for varying such voltages in an inverse manner for shifting control of the system from one pre-set control unit to the other. Each pre-set control unit includes a plurality of adjustable voltage dividers for individually determining the fractions of the pre-set unit input voltage appearing at the different ones of the pre-set unit output terminals.

7 Claims, 4 Drawing Figures

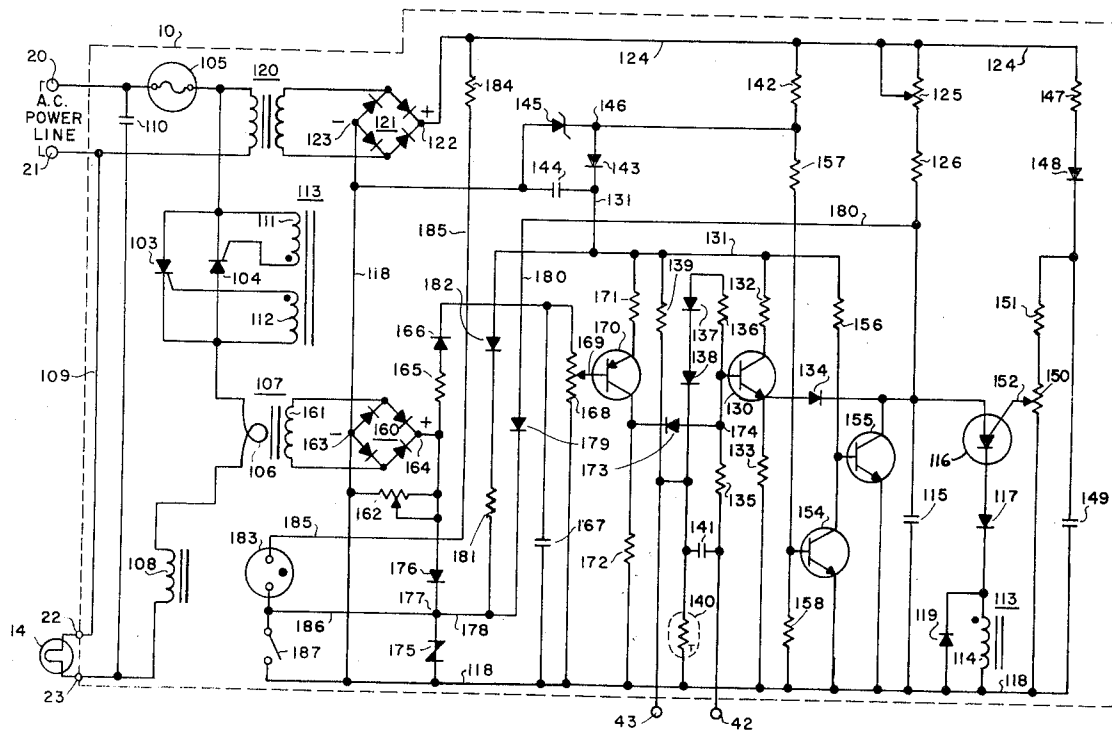

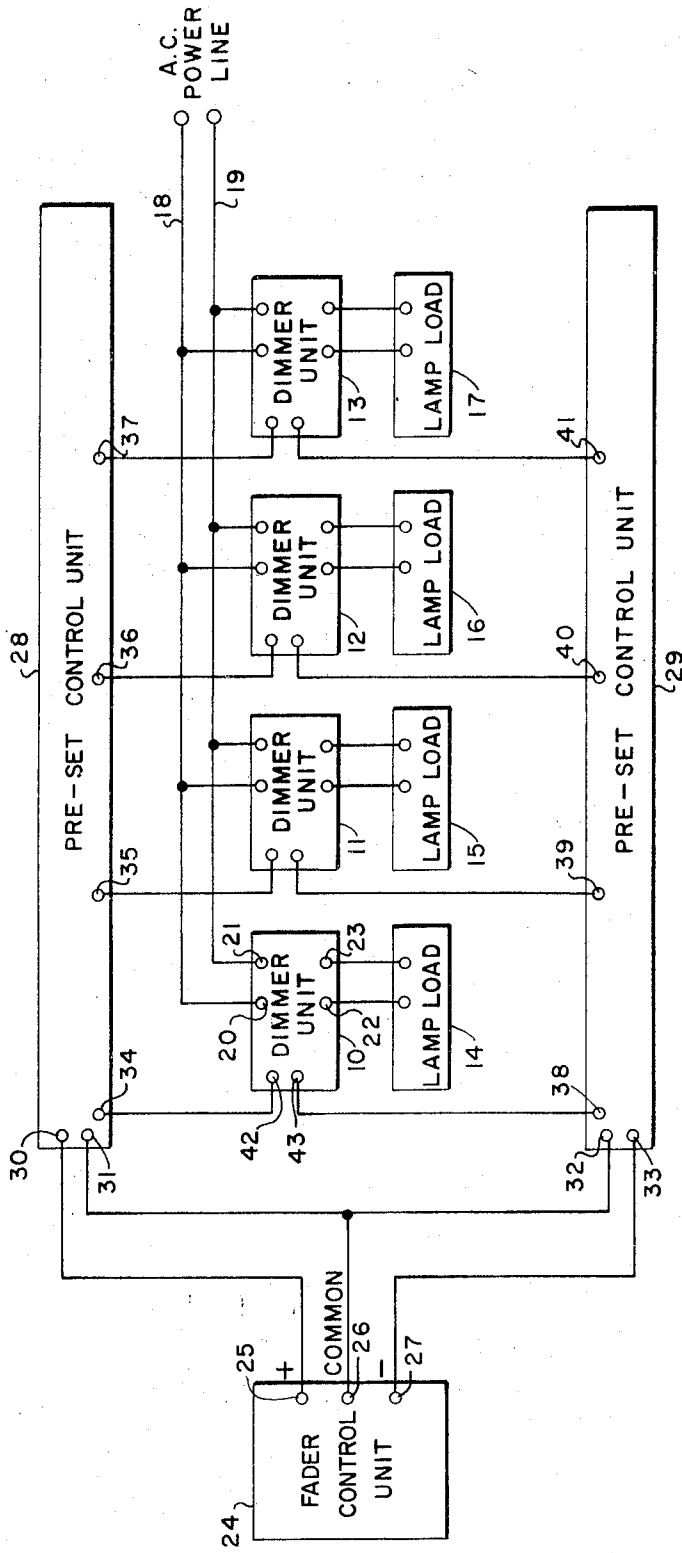

FIG. 1

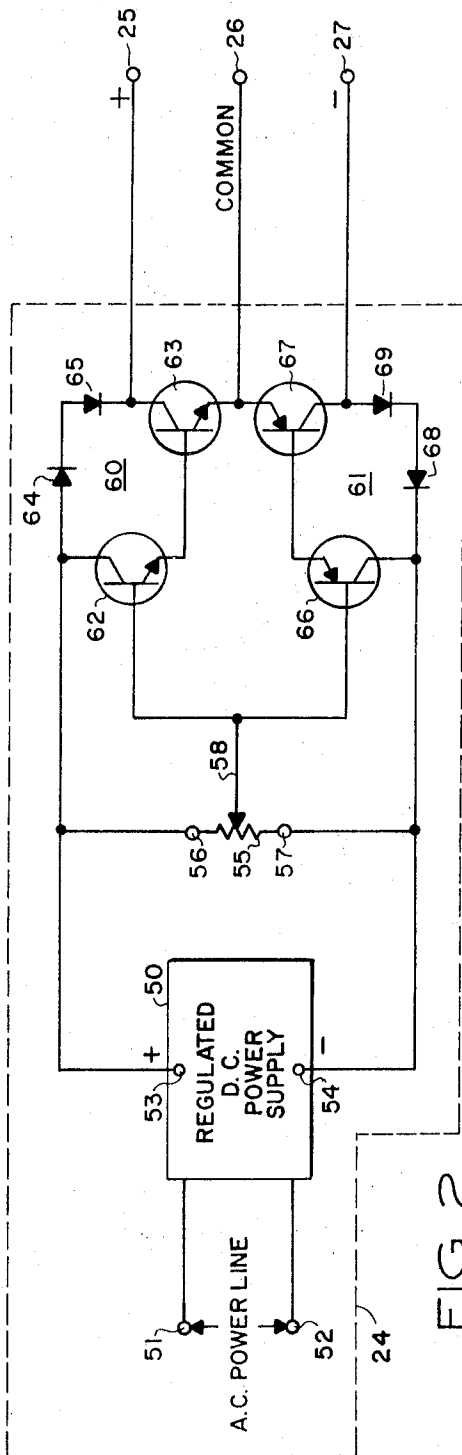

FIG. 2

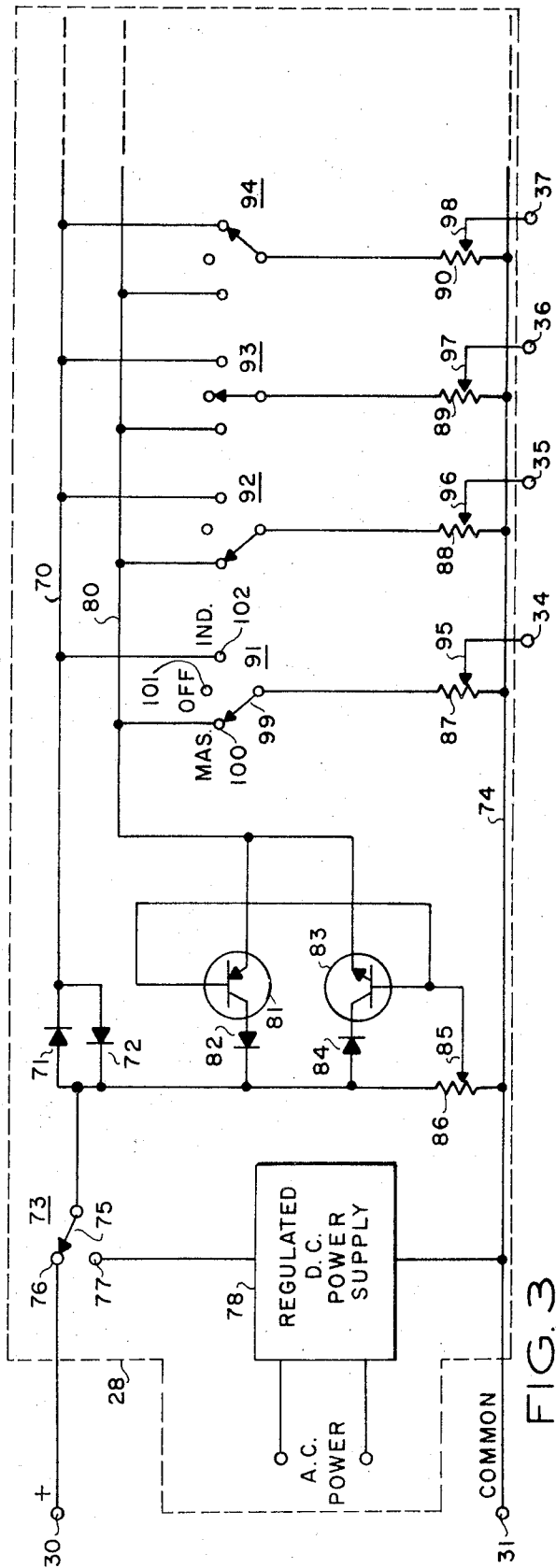

FIG. 3

DIMMER UNIT FOR A LIGHTING CONTROL SYSTEM

BACKGROUND OF THE INVENTION

This invention relates to lighting control systems and is particularly useful in connection with theatre lighting systems, stage lighting systems and the like.

In theatre lighting systems, it is sometimes desired to vary the intensity of different banks of stage lights from one brightness level to another and sometimes with the different banks being changed by different amounts. In such cases, it is sometimes desired that two or more of the lamp banks be changed simultaneously and that the change in each case be a relatively smooth and more or less gradual one. As a consequence, various forms of stage lighting control systems have been heretofore proposed for accomplishing such purposes. In general, however, these previously proposed systems have suffered from one or more limitations and disadvantages which it would be desirable to minimize or overcome. Some heretofore proposed systems are relatively complex and cumbersome, some are relatively expensive and inefficient, while others are difficult to operate and do not provide much flexibility in their manner of use.

It is an object of the invention, therefore, to provide a new and improved lighting control system which is particularly useful for theatrical lighting purposes and which avoids or minimizes one or more of the limitations of systems heretofore proposed for this purpose.

It is another object of the invention to provide a new and improved lighting control system for use in controlling multiple lamp loads in a relatively simple manner and with a relatively large degree of flexibility.

For a better understanding of the present invention, together with other and further objects and features thereof, reference is had to the following description taken in connection with the accompanying drawings, the scope of the invention being pointed out in the appended claims.

BRIEF DESCRIPTION OF THE DRAWINGS

Referring to the drawings:

FIG. 1 is a block diagram of a lighting control system constructed in accordance with the present invention;

FIG. 2 is a detailed schematic circuit diagram of a fader control unit used in the FIG. 1 system;

FIG. 3 is a detailed schematic circuit diagram of one of the pre-set control units used in the FIG. 1 system; and

FIG. 4 is a detailed schematic circuit diagram of one of the dimmer units of the FIG. 1 system.

DESCRIPTION OF THE FIG. 1 SYSTEM

Referring to FIG. 1, there is shown a stage lighting control system having a plurality of controllable dimmer units 10-13 connected between an alternating-current power source (not shown) and different ones of a plurality of lamp loads 14-17. Each of the dimmer units 10-13 includes a pair of alternating-current input terminals which are connected to a pair of alternating-current power supply conductors 18 and 19 which, in use, are connected to an alternating-current power line. The alternating-current input terminals for the dimmer unit 10 are indicated at 20 and 21. Each of the dimmer units 10-13 further includes a pair of alternating-current output terminals for connecting the dimmer unit to its lamp load. The alternating-current out-

put terminals for dimmer unit 10 are indicated at 22 and 23. Each of the dimmer units 10-13 acts to control the fraction of each alternating-current half cycle during which current is allowed to flow from the alternating-current power supply conductors 18 and 19 to its lamp load. In this manner, by controlling the root-mean-square (r.m.s.) value of the current flow to the lamp load, the brightness or intensity of the lamp or lamps contained in the lamp load is controlled.

The lighting control system of FIG. 1 further includes a fader control unit 24 having a set of three output terminals 25, 26 and 27 for supplying separate but interdependent direct-current control voltages to the input terminals of a pair of pre-set control units 28 and 29, the input terminals for pre-set control unit 28 being indicated at 30 and 31 and the input terminals for pre-set control unit 29 being indicated at 32 and 33. For sake of explanation, fader unit output terminals 25, 26 and 27 will be referred to as positive, common and negative output terminals, respectively.

The first pre-set control unit 28 includes a plurality of output terminals 34-37, while the second pre-set control unit 29 includes a plurality of output terminals 38-41. Each of the dimmer units 10-13 includes a pair of direct-current control voltage input terminals, one of which is connected to one of the output terminals of the first pre-set control unit 28 and the other of which is connected to one of the output terminals of the second pre-set control unit 29. Dimmer unit 10, for example, includes a pair of direct-current control voltage input terminals 42 and 43, the former being connected to output terminal 34 of pre-set control unit 28 and the latter being connected to output terminal 38 of pre-set control unit 29. Each of the pre-set control units 28 and 29 includes a plurality of adjustable voltage dividers for individually determining the fractions of the pre-set unit direct-current input voltage which is allowed to appear at the different ones of the pre-set unit output terminals. As such, the voltage divider for the first unit output terminal 34 may be set to determine the upper brightness limit for the lamp load 14 controlled by the dimmer unit 10 and the voltage divider for the second unit output terminal 38 set to determine the lower or minimum brightness level for the lamp load 14 or vice versa.

Fader control unit 24 includes a direct-current power supply and an adjustable voltage divider for varying the magnitude of the direct-current control voltage appearing between output terminals 25 and 26 in an inverse manner with respect to the magnitude of the direct-current control voltage appearing between output terminals 27 and 26. In this manner, the voltage between terminals 27 and 26 is decreased as the voltage between terminals 25 and 26 is increased or vice versa. With the fader unit voltage divider set at one end of its range, one of the voltages assumes a maximum value and the other assumes a substantially zero value. When the fader unit voltage divider is set at the other end of its range, the situation is reversed. Thus, by adjusting the fader unit voltage divider, control of the various lamp loads 14-17 can be shifted from one of the pre-set control units 28 and 29 to the other of such pre-set control units 28 and 29. This enables the simultaneous adjustment of the various lamp loads 14-17 such that some may be turned up brighter and others may be turned down dimmer or turned off in accordance with

the settings of the voltage dividers in the two pre-set control units 28 and 29.

In use, the fader control unit 24 and the pre-set control units 28 and 29 may be mounted on a common control panel in a control booth, while the various dimmer units 10-13 may be located backstage close to the lamp loads to be controlled. Both of the pre-set control units 28 and 29 are of an identical construction. All of the dimmer units 10-13 are also of the same construction. The number of dimmer units and lamp loads may be increased or decreased as desired, four such dimmer units and lamp loads being shown by way of example only.

DESCRIPTION OF THE FIG. 2 FADER CONTROL UNIT

Referring now to FIG. 2, there is shown the details of the fader control unit 24 of the FIG. 1 system. As seen in FIG. 2, the fader control unit 24 includes supply circuit means for supplying a direct-current voltage. This supply circuit means includes a regulated direct-current power supply 50 which is adapted to be coupled to and energized by an alternating-current power line by way of terminals 51 and 52. Power supply 50 produces a regulated direct-current voltage which appears between output terminals 53 and 54 thereof, the former being of positive polarity and the latter of negative polarity. The fader unit 24 further includes adjustable voltage divider means represented by a potentiometer 55 having end terminals 56 and 57 connected to the direct-current output terminals 53 and 54, respectively, of the power supply 50. Potentiometer 55 further includes an intermediate sliding contact 58.

The fader unit 24 also includes first and second direct-current amplifier circuit means 60 and 61 for supplying selected fractions of the direct-current power supply voltage to the first fader unit output terminal pair 25 and 26 and to the second fader unit output terminal pair 27 and 26. The first direct-current amplifier circuit 60 includes a pair of n-p-n type transistors 62 and 63 coupled in cascade. The base electrode of the first transistor 62 is connected to the potentiometer sliding contact 58, the emitter of the first transistor 62 is connected to the base electrode of the second transistor 63 and the emitter of the second transistor 63 is connected to the common output terminal 26. The collector of the first transistor 62 is connected directly to the upper end terminal 56 of the potentiometer 55, while the collector of the second transistor 63 is connected to such upper end terminal 56 by way of diode means represented by a pair of series connected diodes 64 and 65. The collector of the second transistor 63 is also connected to the positive fader unit output terminal 25.

The second direct-current amplifier circuit 61 includes a pair of p-n-p type transistors 66 and 67 connected in cascade with one another. The base electrode of the first transistor 66 is connected to the potentiometer sliding contact 58, the emitter of the first transistor 66 is connected to the base electrode of the second transistor 67 and the emitter of the second transistor 67 is connected to the common output terminal 26. The collector of the first transistor 66 is connected directly to the lower end terminal 57 of the potentiometer 55, while the collector of the second transistor 67 is connected to such lower end terminal 57 by way of diode means represented by series connected diodes 68 and 49.

69. The collector of the second transistor 67 is also connected to the negative fader unit output terminal 27.

For an intermediate setting of the potentiometer sliding contact 58, direct current flows from the upper or positive power supply output terminal 53, through diodes 64 and 65, transistors 63 and 67, diodes 68 and 69 and back to the negative terminal 54 of the power supply 50. Except for the relatively small voltage drops across the diodes 64, 65, 68 and 69, the entire output voltage of the power supply 50 appears between the positive and negative fader unit output terminals 25 and 27. The fraction of this total voltage which appears between the positive voltage output terminal pair 25 and 26, as compared to the fraction of the total voltage which appears between the negative voltage output terminal pair 27 and 26, is determined by the setting of the sliding contact 58. If sliding contact 58 is placed at the maximum upper position so as to contact the upper end terminal 56, the upper transistors 62 and 63 are turned full on and the lower transistors 66 and 67 are turned off. This causes the positive output voltage between terminals 25 and 26 to assume a very nearly zero value and the negative output voltage between terminals 27 and 26 to assume substantially the maximum or total value. If the sliding contact 58 is moved to its lowermost position so as to contact the lower end terminal 57, then the situation is reversed. The positive output voltage between terminals 25 and 26 assumes substantially the maximum value, while the negative output voltage between terminals 27 and 26 assumes substantially a zero value. For intermediate settings of the sliding contact 58, the maximum available voltage is divided between the two outputs in accordance with the setting of the sliding contact 58. As the positive output voltage between terminals 25 and 26 is increased, the negative output voltage between terminals 27 and 26 is decreased and vice versa so that the total of the two voltages always adds up to the maximum available value. Thus, adjustment of the sliding contact 58 serves to vary the two fader unit output voltages in an inverse manner.

Diodes 64 and 65 in the first amplifier circuit 60 serve to produce a voltage drop to provide the necessary driving voltage for the base electrode of the second or output transistor 63 so that the collector-to-emitter voltage of such output transistor 63 may assume a substantially zero value (approximately 0.1 volts) when the output transistor 63 is full on. If diodes 64 and 65 were not used and the collector of transistor 63 were connected directly to the power supply terminal 53, the full on collector-to-emitter voltage of output transistor 63 would be more on the order of a full volt, which value is objectionable in the present system. Diodes 68 and 69 perform a similar function for the second amplifier circuit 61.

DESCRIPTION OF THE FIG. 3 PRE-SET CONTROL UNIT

Referring now to FIG. 3, there is shown the details of the pre-set control unit 28 of the FIG. 1 system. As seen in FIG. 3, the pre-set control unit 28 includes a first voltage supply line 70 which is connected to the positive voltage pre-set unit input terminal 30 by way of oppositely-poled diodes 71 and 72, and a two-position switch 73. Pre-set unit 28 further includes a second voltage supply line 74 which is connected directly to

the common pre-set unit input terminal 31. Switch 73 includes a movable switchblade 75 and fixed switch contacts 76 and 77. With switch 73 in the illustrated position (switchblade 75 against contact 76), the pre-set control unit 28 operates off of the positive output voltage of the fader control unit 24, which voltage appears between pre-set input terminals 30 and 31. When switch 73 is in the opposite position (switchblade 75 against contact 77), the pre-set control unit 28 operates off of an internal direct-current voltage produced by a regulated direct-current power supply 78 which is adapted to be coupled to and energized by an alternating-current power line. Among other things, the internal power supply 78 enables the use of the pre-set control unit 28 without the use of the fader control unit 24.

The pre-set control unit 28 further includes a third voltage supply line 80 which is connected to the positive voltage input terminal 30 by way of a series connected p-n-p type transistor 81 and diode 82 and also by way of a series connected n-p-n type transistor 83 and diode 84. The base electrodes of both of the transistors 81 and 83 are connected to the sliding contact 85 of a voltage dividing potentiometer 86, the end terminals of which are connected between pre-set unit voltage input terminals 30 and 31.

The pre-set control unit 28 also includes a plurality of adjustable voltage divider means represented by potentiometers 87-90 for individually determining the fractions of the pre-set unit input voltage appearing at the different ones of the pre-set unit output terminals 34-37. The end terminals of each of the potentiometers 87-90 are connected between respective ones of three-position switches 91-94 and the lower or common voltage supply line 74. Potentiometers 87-90 include, respectively, sliding contacts 95-98 which are individually connected to different ones of the pre-set unit output terminals 34-37. Considering, for example, the switch 91 for the potentiometer 87, such switch 91 includes a movable switchblade 99 and three stationary contacts 100, 101 and 102 which are positioned for engagement thereby. Contact 100 represents a "master" control position and is connected to the second voltage supply line 80. Contact 101 represents an "off" position and is not connected to anything. Contact 102 represents an "individual" control position and is connected to the upper voltage supply line 70. The other switches 92-94 are constructed and connected in the same manner as switch 91.

In use, the potentiometer switches 91-94 are set to the "master" position (e.g., contact 100 for switch 91) if it is desired that the lamp load controlled by its potentiometer also be susceptible to control by a common or "master" potentiometer 86. In other words, any of the lamp loads connected to any of the individual potentiometers 87-90 having their switches set to the "master" position can be simultaneously controlled by movement of the sliding contact 85 of the "master" control potentiometer 86. For the case of a positive voltage at input terminal 30, the setting of sliding contact 85 determines the conduction level or internal impedance of the transistor 83 and hence the magnitude of the direct-current voltage appearing between the second and common voltage supply lines 80 and 74. Diode 84 serves as a blocking diode to prevent reverse current flow through the transistor 83. If the voltage appearing at input terminal 30 should instead be of negative polarity, then the setting of the master sliding

contact 85 serves to determine the conduction level or internal impedance of the transistor 81 which, in this case, determines the magnitude of the negative voltage appearing between the second and common voltage supply lines 80 and 74. Diode 82 serves as a blocking diode to prevent reverse current flow through the transistor 81. The oppositely-poled diodes 71 and 72 in series with the upper voltage supply line 70 function to match the voltage drops across blocking diodes 82 and 84 so that same net voltage will appear on voltage supply line 70 as appears on the voltage supply line 80 when the potentiometer sliding contact 85 is set to the upper end of the potentiometer 86. The use of both positive-poled and negative-poled transistors 81 and 83 and diodes 82 and 84 enables the same pre-set control unit to be used for either positive or negative voltages on the input terminal 30. For this reason, the second pre-set control unit 29 can be and is of exactly the same construction as the first pre-set control unit 28, even though the input voltage is of opposite polarity.

The lamp loads controlled by any of the potentiometers 87-90 having their switches set to the "off" position (e.g., contact 101 for switch 91) will be turned off when the control potentiometer in fader unit 24 is set so that control of the lamp loads is determined only by the first pre-set control unit 28 and not by the second pre-set control unit 29. The lamp loads controlled by any of the potentiometers 87-90 having their switches set to the "individual" position (e.g., contact 102 for switch 91) are removed from and not subjected to control by the master potentiometer 86. Such lamp loads are controlled only by the settings of the individual output potentiometers 87-90 and the setting of the control potentiometer in the fader control unit 24.

By appropriate settings of the switches 91-94, some of the lamp loads 14-17 can be subjected to simultaneous control by the master potentiometer 86, some can be turned off and some can be subjected to control only by their individual ones of potentiometers 87-90 when the first pre-set control unit 28 is exclusively in control of the lamp loads and the second pre-set control unit 29 is having no effect thereon. Similar considerations apply for the second pre-set control unit 29. Thus, two different sets of stage lighting conditions can be established by the two pre-set control units 28 and 29 and the stage lighting shifted from one to the other by appropriate manipulation of the fader control potentiometer 55. Also, where multiple successive scenes require different lighting conditions, the light condition for the next scene can be set up on the inactive pre-set control unit while the active unit creates the lighting condition for the existing scene.

DESCRIPTION OF THE FIG. 4 DIMMER UNIT

Referring now to FIG. 4, there is shown the details of the dimmer unit 10 of FIG. 1. As seen in FIG. 4, the dimmer unit 10 includes circuit means for supplying an alternating-current voltage. This circuit means is represented by input terminals 20 and 21 which, in use, are connected to an alternating-current power line or other source of alternating-current power.

The dimmer unit 10 also includes switching circuit means adapted to be coupled in series between the alternating-current supply terminals 20 and 21 and the lamp load 14 for enabling current flow through the lamp load 14 when such switching circuit means is conductive. This switching circuit means includes a pair of

oppositely-poled unilateral semiconductor switching devices 103 and 104 of the silicon-controlled rectifier type. Silicon-controlled rectifiers 103 and 104 are connected by their anodes and cathodes in parallel with one another and one end of this parallel combination is connected to the alternating-current input terminal 20 by way of a fuse 105. The other end of this parallel combination is connected to the lamp load output terminal 23 by way of the low impedance primary winding 106 of a current transformer 107 and a radio-frequency choke coil 108. The other lamp load output terminal 22 is connected directly to the second alternating-current input terminal 21 by means of a conductor 109. A radio-frequency by-pass capacitor 110 is connected between the first alternating-current input terminal 20 and the lamp load output terminal 23. Choke coil 108 and capacitor 110 constitute a radio-frequency filter for minimizing leakage to the alternating-current power line of transient-type radio-frequency components generated by the switching action of silicon-controlled rectifiers 103 and 104. The gate electrodes and cathodes of the silicon-controlled rectifiers 103 and 104 are connected to different ones of a pair of secondary windings 111 and 112 of a pulse transformer 113. The primary winding 114 for the pulse transformer 113 is shown near the lower right-hand corner of the drawing and, though shown in a separated manner, is actually wound on the same core structure as are the secondary windings 111 and 112. Silicon-controlled rectifiers 103 and 104 serve to control the fraction of each half cycle of the alternating-current line voltage during which current is allowed to flow from the alternating-current power line terminals 20 and 21 to the lamp load 14.

The dimmer unit 10 further includes a controllable timing mechanism for controlling the conduction intervals of the silicon-controlled rectifiers 103 and 104. This timing mechanism includes trigger circuit means for initiating conduction in the silicon-controlled rectifiers 103 and 104 and timing circuit means for triggering such trigger circuit means during each half cycle of the alternating-current voltage. Such timing circuit means is responsive to the direct-current control voltage supplied to dimmer unit direct-current control terminals 42 and 43 for controlling the trigger timing in accordance with the magnitude of such direct-current control voltage. The timing circuit means includes a timing capacitor 115 and the trigger circuit means includes a semiconductor switching device or trigger device represented by a programmable unijunction transistor 116, the latter being coupled across the timing capacitor 115 for discharging such timing capacitor 115 when the voltage thereacross exceeds a predetermined threshold level established by the programmable unijunction transistor 116. The trigger circuit means further includes circuit means represented by the pulse transformer 113 for sensing the flow of capacitor discharge current through the programmable unijunction transistor 116 and rendering the appropriate one of the silicon-controlled rectifiers 103 and 104 conductive at the onset of such capacitor discharge current. One end of the pulse transformer primary winding 114 is connected by way of a diode 117 to the cathode of the programmable unijunction transistor 116, while the other end of the pulse transformer primary winding 114 is connected to a common current return line 118 for the control portion of the dimmer unit 10. A further diode

119 is connected across the primary winding 114 for damping any reverse polarity spikes that might be produced by the primary winding 114.

The timing circuit means also includes rectifier circuit means for rectifying the alternating-current voltage appearing between alternating-current input terminals 20 and 21. This rectifier circuit means includes an isolation transformer 120 and a diode bridge type full-wave rectifier circuit 121. Output terminals 122 and 123 of rectifier circuit 121 are connected to a voltage supply line 124 and the common current return line 118, respectively, the voltage at terminal 122 being of positive polarity relative to the voltage at terminal 123. There thus appears on voltage supply line 124 a continuous succession of positive-going sinusoidal half cycles representing a full-wave rectified version of the alternating-current voltage appearing between dimmer unit alternating-current input terminals 20 and 21.

The timing circuit means further includes first charging circuit means responsive to the rectified alternating-current voltage appearing on the voltage supply line 124 for charging the timing capacitor 115 at a first rate. This first charging circuit means includes an adjustable resistor 125 and a fixed resistor 126 connected in series between the voltage supply line 124 and the upper end of the timing capacitor 115.

The dimmer unit 10 further includes circuit means for supplying thereto a direct-current control voltage and second charging circuit means responsive to such direct-current control voltage for charging the timing capacitor 115 at a second rate. The circuit means for supplying a direct-current control voltage includes the direct-current input terminals 42 and 43 which, as seen in FIG. 1 are connected to the pre-set control units 28 and 29 for receiving the direct-current voltages appearing at the output terminals 34 and 38 of such pre-set control units 28 and 29. The second charging circuit means includes an n-p-n type transistor 130 having its collector connected to a regulated voltage supply line 131 by way of a resistor 132 and having its emitter connected to the common current return line 118 by way of a resistor 133. The emitter of transistor 130 is also coupled to the upper end of the timing capacitor 115 by means of a diode 134. The direct-current control voltage input terminals 42 and 43 are connected to the base electrode of the transistor 130 by a voltage divider circuit formed by resistors 135 and 136 and diodes 137 and 138. A further resistor 139 is connected between the negative input terminal 43 and the regulated voltage supply line 131, while a thermistor 140 is connected between the negative terminal 43 and the common current return line 118. A radio-frequency by-pass capacitor 141 is connected between the two input terminals 42 and 43 for filtering out any undesired radio-frequency noise which may be supplied to the input terminals 42 and 43.

The dimmer unit 10 further includes a regulated direct-current power supply circuit for supplying regulated direct-current voltage to the regulated voltage supply line 131. This power supply circuit includes a resistor 142, a diode 143 and a filter capacitor or smoothing capacitor 144 which are connected in series between the output terminals 122 and 123 of the bridge rectifier circuit 121. This power supply circuit further includes a Zener diode 145 connected across the diode 143 and smoothing capacitor 144. Zener diode 145 provides the regulating action and, in effect, clamps the

peak voltage at point 146 at a predetermined level of, for example, 25 volts. Capacitor 144 serves to smooth out the undulations in the rectified and peak limited voltage to provide on the voltage supply line 131 a constant amplitude regulated direct-current voltage.

The dimmer unit 10 further includes circuit means responsive to the alternating-current power line voltage for developing a direct-current bias voltage proportional to the peak amplitude thereof and for supplying same to the gate electrode of the trigger device represented by the programmable unijunction transistor 116 for controlling the threshold level of such trigger device 116. This threshold control circuit means includes a resistor 147, a diode 148 and a smoothing capacitor 149 connected in series between the rectified voltage supply line 124 and the common current return line 118. Diode 148 and capacitor 149 function as a peak detector to develop across the capacitor 149 a direct-current voltage proportional to the peak value of the rectified voltage on supply line 124 and, hence, proportional to the peak value of the alternating power line voltage appearing between pre-set unit input terminals 20 and 21. The threshold control circuit further includes a potentiometer 150 and a fixed resistor 151 connected in series across the smoothing capacitor 149. A sliding tap 152 on potentiometer 150 is connected to the gate electrode of the programmable unijunction transistor 116.

The dimmer unit 10 further includes additional switching circuit means coupled across the timing capacitor 115 and responsive to the rectified alternating-current voltage on voltage supply line 124 for completely discharging the timing capacitor 115 at the end of each half cycle of the alternating-current power line voltage. For sake of explanation, such additional switching circuit will be referred to as a "line sync" circuit. Such line sync circuit functions to insure that the discharging of the timing capacitor 115 is synchronized with the timing of the alternating-current power line voltage at terminals 20 and 21 so that the timing capacitor 115 will be completely discharged at the beginning of each half cycle of such alternating-current power line voltage. This line sync circuit includes a pair of cascade coupled n-p-n type transistors 154 and 155, the collector of the former being connected to the base electrode of the latter. Transistor 155 is connected across the timing capacitor 115 by means of its collector and emitter electrodes. The collector of the first transistor 154 is connected to the regulated voltage supply line 131 by way of a resistor 156 and the emitter of such transistor 154 is connected directly to the common current return line 118. The base electrode of the first transistor 154 is connected to a point intermediate a pair of voltage dividing resistors 157 and 158 which are connected in series between the power supply junction point 146 and the common current return line 118. The negative-going voltage spike appearing at this junction point 146 at the end of each alternating current half cycle serves to momentarily turn off the normally conductive first transistor 154 which, in turn, momentarily turns on the normally non-conductive second transistor 155.

The dimmer unit 10 further includes an overload protection system for preventing damage to the silicon-controlled rectifiers 103 and 104 and other components in the lamp load circuit in the event that excessive current should be drawn by the lamp load 14. As will be seen, this overload protection system includes

means for protecting against both excessive values of average current flow as well as excessive values of peak current flow to the lamp load 14. This overload protection system includes circuit means for sensing the alternating current flowing to the lamp load 14 and developing a voltage signal proportional to the instantaneous amplitude thereof. This current sensing circuit means includes the current transformer 107 and a diode bridge type full-wave rectifier circuit 160. The low impedance primary winding 106 of the current transformer 107 is connected in series between the silicon-controlled rectifiers 103 and 104 and the lamp load 14, while the secondary winding 161 of the current transformer 107 is connected across a first diagonal of the bridge circuit 160. An adjustable load resistor 162 is connected between output terminals 163 and 164 of the bridge circuit 160. Terminal 163 is also connected to the common current return line 118. The polarity of the diodes in bridge circuit 160 are such that the voltage fluctuations appearing at output terminal 164 are all of positive polarity, such fluctuations corresponding in waveform to a full-wave rectified version of the current fluctuations passing through the primary winding 106 of the current transformer 107.

The overload protection system further includes circuit means coupled to the current sensing circuit means represented by transformer 107 and bridge circuit 160 for clamping the dimmer unit 10 at a predetermined operating level when the average value of the current flowing to lamp load 14 exceeds a predetermined value. This average overload circuit means includes a resistor 165, a diode 166 and a filter capacitor 167 connected in series between bridge circuit output terminal 164 and the common current return line 118. Diode 166 and capacitor 167 function as a detector circuit to develop across the capacitor 167 a direct-current voltage proportional to the average value of the alternating current flowing to the lamp load 14. By "average" value is meant the average value over a half cycle, as opposed to a full cycle, or, more accurately, the average value over several cycles with the assumption that all half cycles are of the same polarity. The average overload circuit further includes a voltage dividing potentiometer 168 having a sliding contact 169 connected to the base electrode of a p-n-p type transistor 170. The emitter of transistor 170 is connected to the regulated voltage supply line 131 by way of a resistor 171, while the collector of transistor 170 is connected to the current return line 118 by way of a resistor 172. The collector of transistor 170 is further connected to the base electrode of the charging circuit transistor 130 by way of a diode 173. As will be seen, the average overload circuit serves to clamp the voltage level at junction point 174 at a fixed predetermined value whenever the average value of the lamp load current exceeds a desired maximum level.

The overload protection system further includes circuit means coupled to the current sensing circuit means represented by transformer 107 and rectifier 160 for disabling the dimmer unit 10 when the peak value of the current flowing to the lamp load 14 exceeds a predetermined value. This peak overload circuit includes a semiconductor breakover device in the form of a silicon symmetrical switch 175 which is coupled to the rectifier output terminal 164 by way of a diode 176. The other end of the silicon symmetrical switch 175 is connected to the common current return line 118. The

silicon symmetrical switch 175 is a bilateral diode switch device which has a fairly high internal impedance until the voltage thereacross exceeds a breakover level, following which the internal impedance of the device 175 becomes relatively small. Thus, when one of the unidirectional pulses at the rectifier output terminal 164 exceeds the breakover level of the device 175, such device becomes conductive and effectively shorts the junction point 177 to the current return line 118. This junction point 177 is connected to the timing capacitor 115 by way of conductor wire 178, diode 179 and conductor wire 180. Thus, when conductive, the device 175, in effect, shorts out the timing capacitor 115. This disables dimmer unit 10 and prevents further current flow to the lamp load 14. Holding current for maintaining the device 175 conductive once the breakover level has been exceeded is provided by way of conductor wire 178, resistor 181 and diode 182, the latter being connected to the regulated voltage supply line 131.

When the silicon symmetrical switch 175 is conductive, a warning lamp 183 is turned on. Current for energizing the warning lamp 183 flows from the rectified voltage supply line 124 by way of a resistor 184, conductor wire 185, the lamp 183, conductor wire 186 and the silicon symmetrical switch 175 to the common current return line 118. The peak overload circuit may be reset by momentarily depressing a spring-loaded push-button switch 187 for purposes of momentarily closing same. This shorts out the silicon symmetrical switch 175 and turns same off.

OPERATION OF THE FIG. 4 DIMMER UNIT

Considering now the operation of the dimmer unit 10, the power switching mechanism represented by silicon-controlled rectifiers 103 and 104 serves to control the fraction of each half cycle during which current is allowed to flow from the alternating-current power line terminals 20 and 21 to the lamp load 14, silicon-controlled rectifier 103 allowing current flow in one direction and silicon-controlled rectifier 104 allowing current flow in the opposite direction. Silicon-controlled rectifiers 103 and 104 are triggered by pulses produced by the programmable unijunction transistor 116 and supplied to the gate electrodes of such silicon-controlled rectifiers 103 and 104 by the pulse transformer 113. Each pulse triggers the silicon-controlled rectifier which at that moment has a positive voltage on its anode and a negative voltage on its cathode, such silicon-controlled rectifier thereafter being turned off when the alternating-current voltage reverses polarity.

The programmable unijunction transistor 116 is normally non-conductive. It becomes conductive and generates a current flow pulse when its anode voltage exceeds its gate electrode voltage. Thus, the setting of sliding contact 152 on the peak detector circuit potentiometer 150 establishes the voltage threshold level at which the timing capacitor 115 will be discharged by the programmable unijunction transistor 116.

At the beginning of each half cycle of the alternating-current power line voltage at terminals 20 and 21, the timing capacitor 115 is completely discharged. If this was not accomplished by the programmable unijunction transistor 116, it will have been accomplished by the line sync circuit provided by transistors 154 and 155. Transistor 154 is normally conductive and transis-

tor 155 is normally non-conductive. At the end of each half cycle of the power line voltage, there appears at the power supply junction point 146 a negative-going voltage spike produced when the pulsating voltage on the voltage supply line 124 falls below the breakover level of the Zener diode 145. This negative-going voltage spike is supplied by way of resistor 157 and momentarily turns off the first line sync transistor 154. This momentarily turns on the second transistor 155 and the resulting collector-to-emitter current flow therethrough discharges the timing capacitor 115.

During the first portion of each half cycle, the timing capacitor 115 is charged by two different charging circuit mechanisms, one of which is responsive to the direct-current control voltage applied across the dimmer unit input terminals 42 and 43 and the other of which is responsive to the pulsating full-wave rectified voltage appearing on voltage supply line 124. For convenience, the control voltage responsive mechanism will be referred to as the "fast" charge mechanism and the rectified voltage responsive mechanism will be referred to as the "slow" charge mechanism.

Considering first the fast charge mechanism, the timing capacitor 115 is charged at a relatively rapid rate by the flow of direct current from the regulated voltage supply line 131, through resistor 132, through the collector-to-emitter portion of transistor 130 and through diode 134 to capacitor 115. The actual charge rate is determined by the internal impedance of the transistor 130 which is, in turn, determined by the magnitude of the direct-current control voltage applied across dimmer unit input terminals 42 and 43. These input terminals 42 and 43 are connected to the base electrode of transistor 130 by the voltage divider formed by resistors 135 and 136. The greater the magnitude of the direct-current control voltage, the lower the internal impedance of the transistor 130 and the faster the rate of charging of the timing capacitor 115. As will be seen, the bias on the gate electrode of the programmable unijunction transistor 116 is such that the charging of the timing capacitor 115 by the fast charge transistor 130 alone will not be sufficient to trigger the programmable unijunction transistor 116.

To the fast charge voltage being built up across the timing capacitor 115, there is added a slow charge voltage supplied thereto by the slow charge mechanism which is represented by resistors 125 and 126. Each of the positive-going half cycles of the pulsating voltage on supply line 124 causes an approximately square law charging of the timing capacitor 115. For simplicity of understanding, this sine wave charging can be thought of as taking over and continuing the charging of the timing capacitor 115 following completion of the initial fast charge applied by way of fast charge transistor 130. This additional slow charge component continues until the voltage across timing capacitor 115 exceeds the threshold level of the programmable unijunction transistor 116. At this point, the programmable unijunction transistor 116 becomes conductive and the timing capacitor 115 is very quickly discharged by way of such transistor 116 and the primary winding 114 of pulse transformer 113. The pulse produced by this sudden flow of capacitor discharge current through the primary winding 114 triggers the appropriate one of the silicon-controlled rectifiers 103 and 104.

The larger the magnitude of the direct-current control voltage at terminals 42 and 43, the quicker is the

timing capacitor 115 charged up to the threshold level and the sooner in each half cycle is fired the appropriate one of silicon-controlled rectifiers 103 and 104. Thus, the greater is the fraction of each half cycle during which current flows through the lamp load 14 and, hence, the greater is the brightness of the lamps in lamp load 14.

In order to provide a preliminary setup adjustment for the dimmer unit 10, the maximum value of direct-current control voltage is applied between the input terminals 42 and 43. The sliding contact 152 on the potentiometer 150 is then adjusted to adjust the bias on the gate electrode of the programmable unijunction transistor 116 to give the maximum desired brightness level (usually "full on") for the lamp load 14. Next, the voltage difference between input terminals 42 and 43 is set to zero and the adjustable resistor 125 in the slow charge circuit is adjusted so that the programmable unijunction transistor 116 just barely does not fire during each half cycle. In other words, resistor 125 is adjusted so that the timing capacitor 115 will be charged up by the sine wave charging to just slightly less than the threshold level of unijunction transistor 116 during the course of a complete half cycle. Lack of triggering of the programmable unijunction transistor 116 keeps current from flowing to the lamp load 14 and, hence, causes the lamp load 14 to be turned off.

Variations in the peak amplitude of the alternating power line voltage at dimmer unit input terminals 20 and 21 will cause corresponding variations in the peak amplitude of the pulsating rectified voltage on voltage supply line 124. This, in turn, will cause undesired variations in the time required for the slow charge circuit to charge the timing capacitor 115 up to the unijunction transistor threshold level. Such an undesired change in the trigger timing is offset and compensated for by an automatic and corresponding change in the magnitude of the bias voltage supplied to the gate electrode of the unijunction transistor 116. Thus, if the alternating-current line voltage amplitude increases, which increase would cause an earlier firing of the unijunction transistor 116, the bias voltage on the gate electrode of unijunction transistor 116 is increased a proportionate amount, which increase would cause a later firing of the unijunction transistor 116. These two factors offset one another so that the unijunction transistor 116 is fired at the desired time.

Diodes 137 and 138 in the direct-current control voltage input circuit of the fast charge transistor 130 serve to provide a further increase in the charge rate for very low values of direct-current control voltage. In other words, until the internal threshold or breakover level of the diodes 137 and 138 is exceeded, such diodes remain essentially non-conductive and the full value of the direct-current control voltage is applied to the base electrode of the fast charge transistor 130. When such internal thresholds are exceeded and the diodes 137 and 138 become conductive, the voltage divider formed by resistors 135 and 136 provide a voltage dividing action such that the control voltage applied to the base electrode of transistor 130 corresponds to approximately one-half of the control voltage value appearing between input terminals 42 and 43. Thus, for very low values of direct-current control voltage, an even faster charge rate is employed by the fast charge circuit. This makes the control voltage amplitude ver-

sus lamp load brightness curve more nearly square law in nature.

Thermistor 140 provides temperature compensation to compensate for changes with temperature in the operating characteristics of the fast charge transistor 130, the diode 134 and the programmable unijunction transistor 116.

Considering now the overload protection portion of the dimmer unit 10, the current transformer 107 senses the current flow to the lamp load 14 and produces across the secondary winding 161 voltage pulses proportional in amplitude to the amplitude of the lamp load current pulses. These voltage pulses are full-wave rectified by the bridge rectifier circuit 160 so that all of the pulses appearing at the output terminal 164 thereof are of positive polarity.

The average overload portion of the overload protection system senses the average value of the positive polarity pulses at rectifier output terminal 164 and clamps the base electrode of the fast charge transistor 130 at a predetermined and relatively small voltage level when such average value exceeds a desired maximum value. More particularly, filter capacitor 167 receives the positive polarity pulses appearing at rectifier output terminal 164 and integrates or averages same to produce across such capacitor 167 a voltage proportional to the average value thereof and, hence, to the average value of the lamp load current. When the lamp load current is below the overload level, the voltage developed across filter capacitor 167 is not sufficient to turn off the normally conductive transistor 170. With the transistor 170 conductive, there is developed across the resistor 172 a voltage which keeps the clamping diode 173 turned off. When the lamp load current exceeds the overload level, on the other hand, the resulting average voltage developed across the filter capacitor 167 turns off the transistor 170. This decreases the voltage drop across collector resistor 172 and turns on the clamping diode 173. This enables such diode 173 to clamp the base electrode of the fast charge transistor 130 to reduce the fast charge to a maximum safe value and to prevent such safe value from being exceeded by either the existing or subsequent values of the direct-current control voltage applied to the input terminals 42 and 43. The threshold level for this average overload circuit is set at the desired value by proper adjustment of the sliding contact 169 of the potentiometer 168.

Considering now the peak overload portion of the overload protection system, the silicon symmetrical switch 175 serves to monitor the peak value of the positive pulses appearing at rectifier output terminal 164. The breakover level of silicon symmetrical switch 175 is equal to the peak voltage value at the rectifier output terminal 164 corresponding to the maximum peak value of current flow which is desired through the lamp load 14. When the peak amplitude of one or more of the pulses at rectifier output terminal 164 exceed this breakover level, the silicon symmetrical switch 175 becomes conductive and provides a very low impedance connection between the junction point 177 and the common current return line 118. Since the silicon symmetrical switch 175 is connected in parallel with the timing capacitor 115 by means of conductor 178, diode 179 and conductor 180, this effectively shorts out the timing capacitor 115 and prevents any further charging thereof. This prevents further triggering of the silicon-

controlled rectifiers 103 and 104 and, hence, prevents further current flow to the lamp load 14. Holding current for keeping the silicon symmetrical switch 175 conductive is supplied thereto from the regulated power supply 142-145 by way of diode 182, resistor 181 and conductor 178.

When the silicon symmetrical switch 175 is conductive, the peak overload warning lamp 183 is lit by current flow by way of resistor 184, conductor 185, lamp 183, conductor 186 and silicon symmetrical switch 175. The peak overload circuit may be reset by momentarily depressing or closing the spring-loaded push-button switch 187. This shorts out the silicon symmetrical switch 175 and turns same off. Diodes 176 and 182 prevent any reverse current flow therepast by way of the warning lamp 183 when the silicon symmetrical switch is not conductive.

While there has been described what is at present considered to be a preferred embodiment of this invention, it will be obvious to those skilled in the art that various changes and modifications may be made therein without departing from the invention, and it is, therefore, intended to cover all such changes and modifications as fall within the true spirit and scope of the invention.

What is claimed is:

1. A dimmer unit for use in a lighting control system and comprising:

circuit means for supplying an alternating-current voltage;

circuit means for supplying a direct-current control voltage;

switching circuit means adapted to be coupled in series between the alternating-current supply circuit means and a lamp load for enabling current flow to the lamp load when such switching circuit means is conductive;

a timing capacitor;

a trigger device coupled to the timing capacitor for discharging same and supplying a trigger pulse to the switching circuit means when the charge on the timing capacitor exceeds a predetermined threshold level; and controllable charging circuit means responsive to the direct-current control voltage for charging the timing capacitor at a rate dependent on the magnitude of such direct-current control voltage.

2. A dimmer unit in accordance with claim 1 wherein the trigger device is a programmable unijunction transistor.

3. A dimmer unit in accordance with claim 1 and including:

means for controlling the threshold level of the trigger device;

and circuit means responsive to the alternating-

current voltage for developing a direct-current bias voltage proportional to the peak amplitude thereof and for supplying such bias voltage to the trigger device threshold control means for compensating for changes in magnitude of the alternating-current voltage.

4. A dimmer unit in accordance with claim 3 wherein the trigger device is a programmable unijunction transistor having anode, cathode and gate electrodes, the anode and cathode electrodes being coupled across the timing capacitor and the gate electrode being coupled to the circuit means for developing the direct-current bias voltage.

5. A dimmer unit for use in a lighting control system and comprising:

circuit means for supplying an alternating-current voltage;

circuit means for supplying a direct-current control voltage;

first switching circuit means adapted to be coupled in series between the alternating-current supply circuit means and a lamp load for enabling current flow to the lamp load when such switching circuit means is conductive;

capacitor means;

second switching circuit means coupled across the capacitor means for discharging same when the voltage thereacross exceeds a predetermined threshold level;

circuit means for sensing the flow of capacitor discharge current and rendering the first switching circuit means conductive at the onset thereof;

rectifier circuit means for rectifying the alternating-current voltage;

first charging circuit means responsive to the rectified alternating-current voltage for charging the capacitor means at a first rate;

and second charging circuit means responsive to the direct-current control voltage for charging the capacitor means at a second rate.

6. A dimmer unit in accordance with claim 5 and including third switching circuit means coupled across the capacitor means and responsive to the rectified alternating-current voltage for completely discharging the capacitor means at the end of each half cycle of the alternating-current voltage.

7. A dimmer unit in accordance with claim 6 and including circuit means responsive to the rectified alternating-current voltage for developing a direct-current bias voltage proportional to the peak amplitude thereof and for supplying such bias voltage to the second switching circuit means for controlling the threshold level thereof for compensating for changes in magnitude of the alternating-current voltage.

* * * * *