



US00D960803S

(12) **United States Design Patent** (10) **Patent No.:** **US D960,803 S**
Kaoud et al. (45) **Date of Patent:** **** Aug. 16, 2022**

- (54) **VEHICLE TAILGATE**
- (71) Applicant: **Ford Global Technologies, LLC**,
Dearborn, MI (US)
- (72) Inventors: **Ehab N. Kaoud**, Livonia, MI (US);
William K. Moore, West Bloomfield,
MI (US); **Andrew Bazinski**, Ferndale,
MI (US)
- (73) Assignee: **Ford Global Technologies, LLC**,
Dearborn, MI (US)
- (**) Term: **15 Years**
- (21) Appl. No.: **29/723,979**
- (22) Filed: **Feb. 12, 2020**
- (51) **LOC (13) Cl.** **12-16**
- (52) **U.S. Cl.**
USPC **D12/196**
- (58) **Field of Classification Search**
USPC D12/86, 91, 93, 163, 164, 165, 166, 167,
D12/169, 171, 172, 173, 190, 196, 216
CPC B60R 9/06; B60R 19/02; B60R 19/04;
B60R 19/18; B60R 19/44; B60R 19/48;
B62D 35/02; B62D 39/00; B62D 65/16;
B62D 21/12; B29C 45/16
See application file for complete search history.

- D890,054 S * 7/2020 Platto D12/196
- D890,055 S * 7/2020 Platto D12/196
- D897,255 S * 9/2020 Zipfel D12/196
- D908,572 S * 1/2021 Langhals D12/196
- D924,764 S * 7/2021 Wraith D12/196
- D930,540 S * 9/2021 Lee D12/196
- D937,726 S * 12/2021 Meyer D12/196

OTHER PUBLICATIONS

Vehicle Tailgates. (Design—© Questel) orbit.com. [Online PDF compilation of references] 39 pgs. Print Dates Range Jul. 16, 2020-Nov. 5, 2018 [Retrieved Dec. 14, 2021].*
Vijayenthiran, Viknesh. "2021 Ford F-150 Spy Shots." Feb. 21, 2020. Motor Authority, https://www.motorauthority.com/news/1033072_2021-ford-f-150-pickup-spy-shots.*

(Continued)

Primary Examiner — Manpreet S Matharu
Assistant Examiner — Suzanne E Tisdell

(57) **CLAIM**

The ornamental design for a vehicle tailgate, as shown and described.

DESCRIPTION

FIG. 1 is a front elevational view of a vehicle tailgate showing our new design;
FIG. 2 is a left side elevational view thereof;
FIG. 3 is a right side elevational view thereof;
FIG. 4 is a top plan view thereof;
FIG. 5 is a bottom plan view thereof;
FIG. 6 is a top, front, and left side perspective view thereof; and,
FIG. 7 is a bottom, front and left side perspective view thereof.
Areas shown in half-tone shading and surrounded by broken lines show portions of the vehicle tailgate that form no part of the claimed design.

1 Claim, 7 Drawing Sheets

(56) **References Cited**
U.S. PATENT DOCUMENTS

- D556,110 S 11/2007 Schiavone
- D560,584 S 1/2008 Tant
- D807,268 S * 1/2018 Dunshee D12/196
- D827,533 S * 9/2018 Platto D12/196
- D840,306 S * 2/2019 Kozub D12/196
- D849,627 S * 5/2019 Zipfel D12/196
- D855,529 S * 8/2019 Dewitt D12/196
- D856,882 S * 8/2019 Ninov D12/196

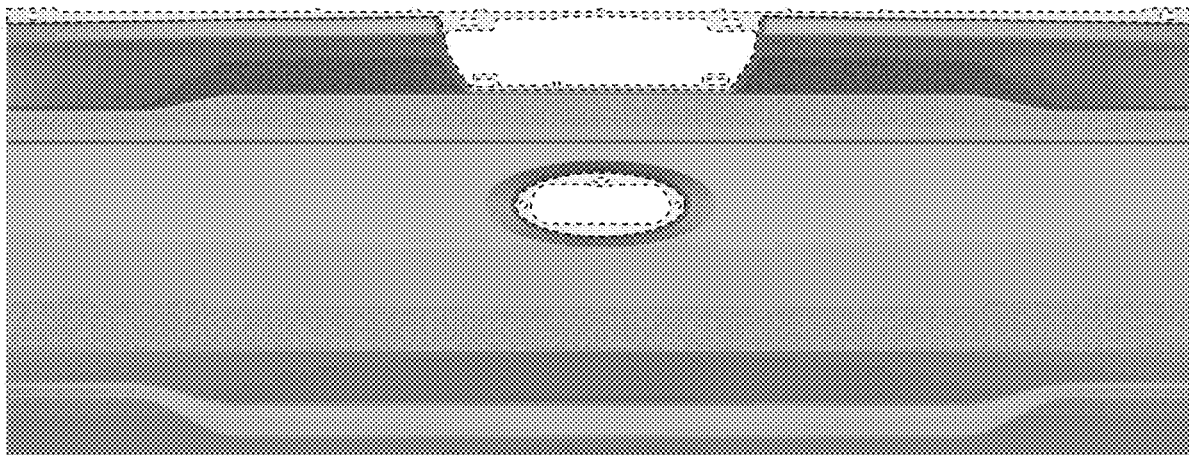

(56)

References Cited

OTHER PUBLICATIONS

Hoffman, Connor. "Spy Photos Give an Even Closer Look at the 2021 Ford F-150." Feb. 21, 2020. Car and Driver. <https://www.caranddriver.com/news/a31041037/2021-ford-f-150-spied/>.*

Smith, Christopher. "2021 Ford F-150 New Front End Spied Completely Uncovered." Feb. 21, 2020. Motor 1. <https://www.motor1.com/news/399836/2021-ford-f-150-face-revealed/>.*

Andrew Wendler, The 2021 Ford F-150, Spied Testing, Looks Pretty Evolutionary, May 8, 2019 <https://www.caranddriver.com/news/a27409108/2021-ford-f-150-pickup-spied/>.

* cited by examiner

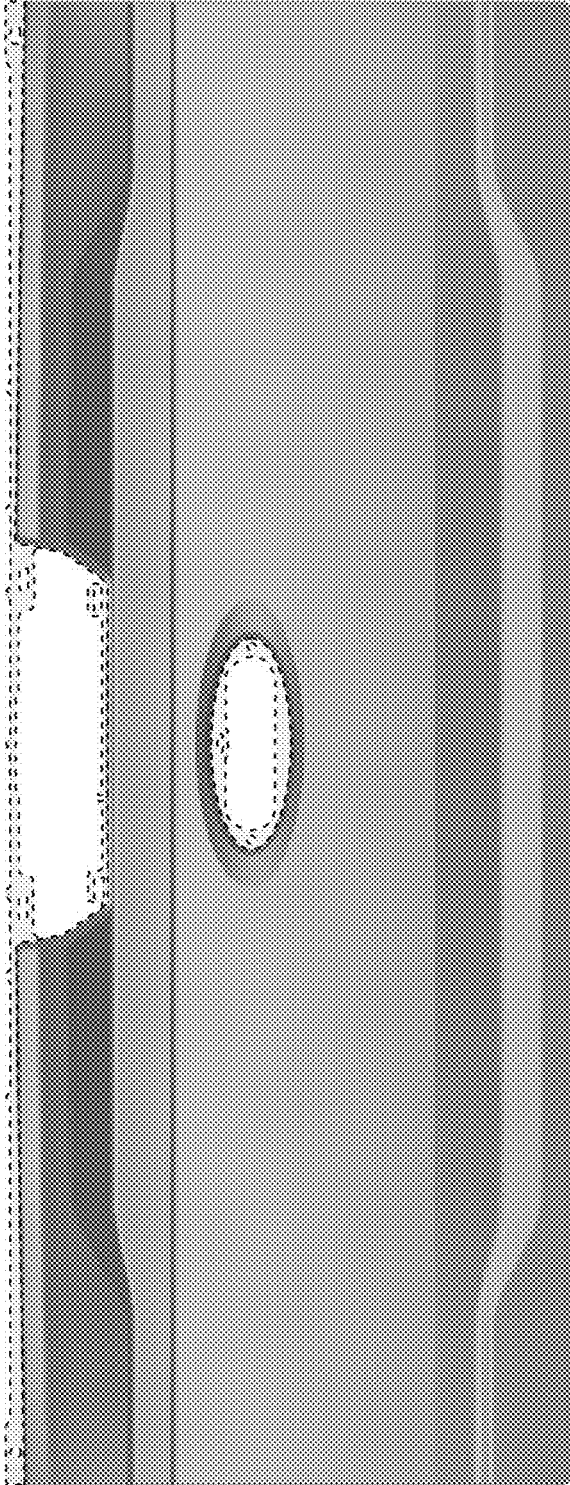

Fig. 1

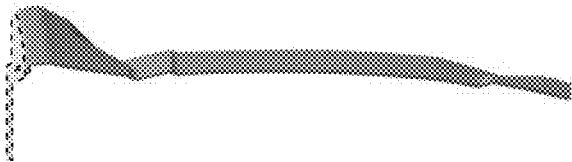

Fig. 2



Fig. 3

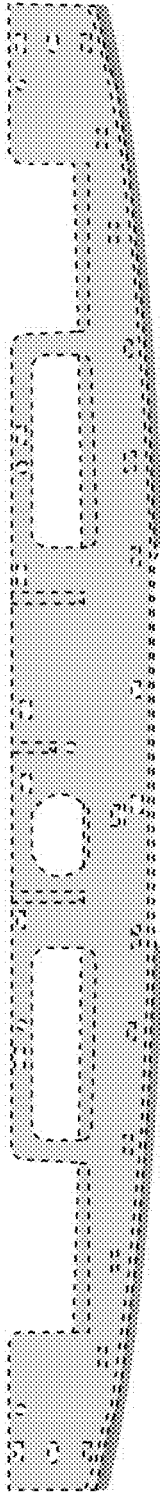

Fig.4

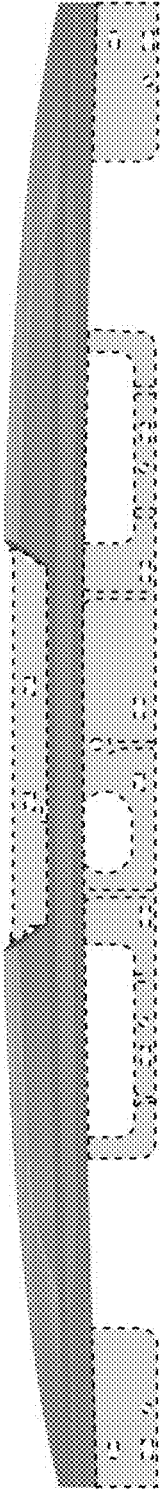

Fig. 5

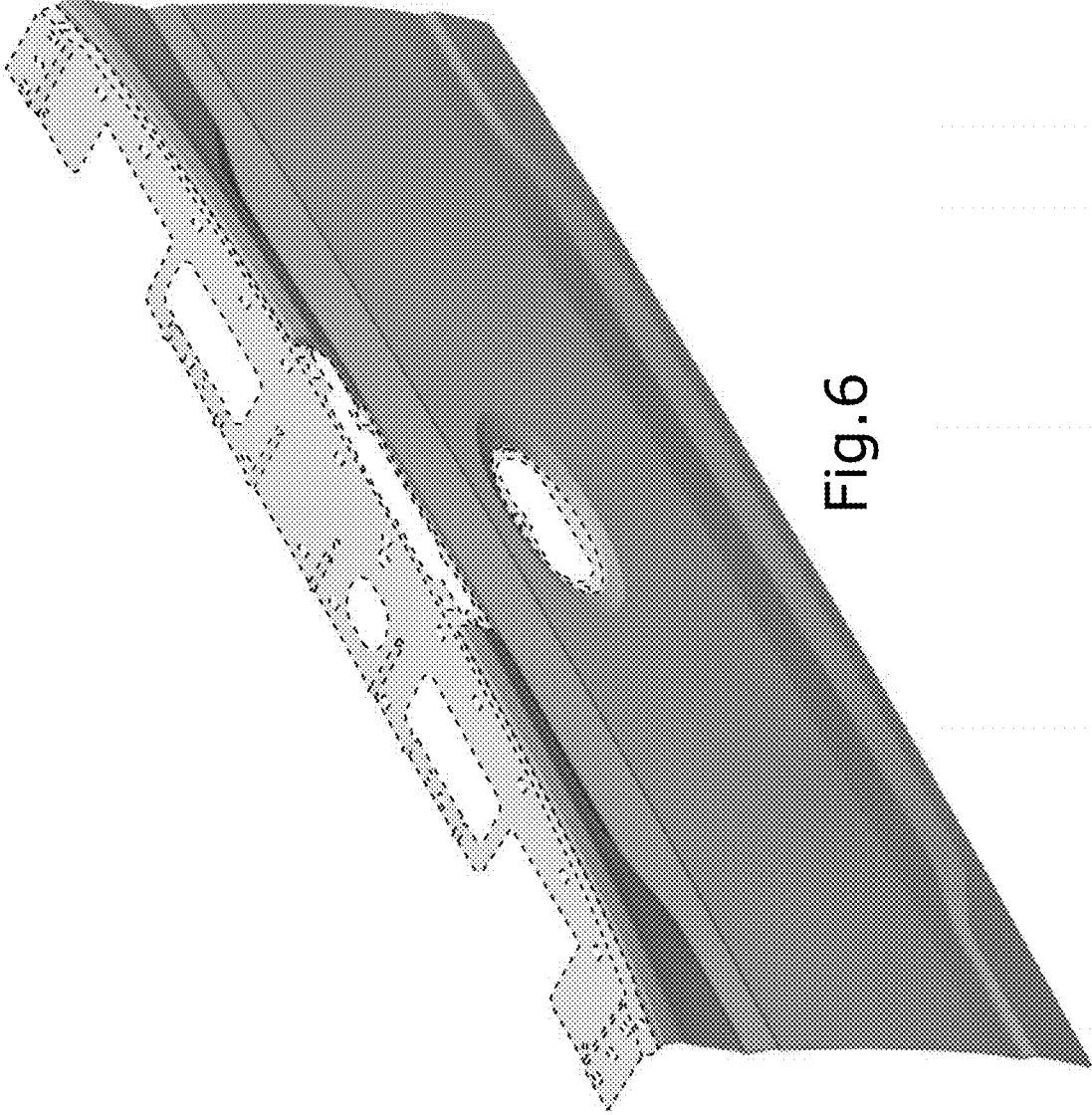

Fig. 6



Fig. 7