



US00D754839S

(12) **United States Design Patent**  
**Aruga**

(10) **Patent No.:** **US D754,839 S**

(45) **Date of Patent:** **\*\* Apr. 26, 2016**

(54) **OUTLET OF AIR CONDITIONING FOR AIRCRAFT**

(71) Applicant: **mitsubishi aircraft CORPORATION**, Nagoya-shi, Aichi (JP)

(72) Inventor: **Hiroyasu Aruga**, Tokyo (JP)

(73) Assignee: **mitsubishi aircraft CORPORATION**, Aichi (JP)

(\*\*) Term: **15 Years**

(21) Appl. No.: **29/534,842**

(22) Filed: **Jul. 31, 2015**

**Related U.S. Application Data**

(62) Division of application No. 29/458,268, filed on Jun. 18, 2013.

(51) **LOC (10) Cl.** ..... **23-04**

(52) **U.S. Cl.**

USPC ..... **D23/393**

(58) **Field of Classification Search**

USPC ..... D23/388-393, 342, 366, 356, 385, 370, D23/371, 351, 354, 386; 454/309, 275-277, 454/284, 287; D26/118, 72, 152; D12/319, D12/345

CPC . B64D 13/00; B64D 2013/003; B64D 13/006  
See application file for complete search history.

(56) **References Cited**

**U.S. PATENT DOCUMENTS**

D203,484 S	1/1966	Rousey et al.	
D263,070 S	2/1982	Metz et al.	
D373,417 S	9/1996	Lee	
D377,231 S *	1/1997	Degelmann	D26/77
D384,769 S *	10/1997	Holten	D26/118
6,273,592 B1	8/2001	Herst et al.	
6,402,345 B1	6/2002	Fishman	

D481,820 S \* 11/2003 Watt ..... D26/121  
6,652,118 B2 \* 11/2003 Shemitz ..... F21S 4/003  
362/225

D490,876 S 6/2004 Okazaki et al.  
7,246,924 B2 \* 7/2007 Pfund ..... F21V 11/02  
362/290

D561,384 S 2/2008 Hukle et al.  
D572,358 S 7/2008 Natrass et al.  
D597,248 S \* 7/2009 Lee ..... D26/122  
D601,296 S \* 9/2009 Lee ..... D26/122  
D602,579 S 10/2009 Stone  
D605,281 S 12/2009 Kern  
D618,331 S \* 6/2010 Stone ..... D23/373

(Continued)

*Primary Examiner* — David Muller

*Assistant Examiner* — Nathan Johnston

(74) *Attorney, Agent, or Firm* — Birch, Stewart, Kolasch & Birch, LLP

(57) **CLAIM**

The ornamental design for an outlet of air conditioning for aircraft, as shown and described.

**DESCRIPTION**

FIG. 1 is a perspective view of an outlet of air conditioning for aircraft according to my new ornamental design.

FIG. 2 is a front elevation view thereof.

FIG. 3 is a rear elevation view thereof.

FIG. 4 is a top plan view thereof.

FIG. 5 is a bottom plan view thereof.

FIG. 6 is a left side elevation view thereof.

FIG. 7 is a right side elevation view thereof.

FIG. 8 is an enlarged cross-sectional view taken along the line 8-8 in FIG. 2.

FIG. 9 is an enlarged cross-sectional view taken along the line 9-9 in FIG. 2; and,

FIG. 10 is a referential view showing use thereof.

The outlet of air conditioning for aircraft is shown with a symbolic break in its length on one end. The appearance of any portion of the article outside the break lines forms no part of the claimed design.

**1 Claim, 9 Drawing Sheets**

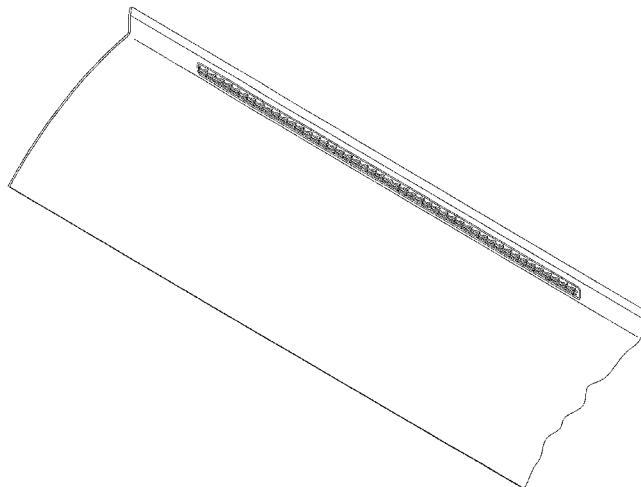

# US D754,839 S

Page 2

---

(56)

## References Cited

### U.S. PATENT DOCUMENTS

D620,570 S 7/2010 Thomas  
8,092,040 B2 \* 1/2012 Wu ..... F21V 7/0016  
362/217.03  
D654,161 S \* 2/2012 Holland ..... D23/373

D697,652 S \* 1/2014 Savani ..... D26/76  
D710,985 S \* 8/2014 Gassman ..... D23/373  
2005/0271468 A1 \* 12/2005 Messerschmidt ..... E03F 5/06  
404/4

2013/0153764 A1 6/2013 Momomura et al.

\* cited by examiner

FIG. 1

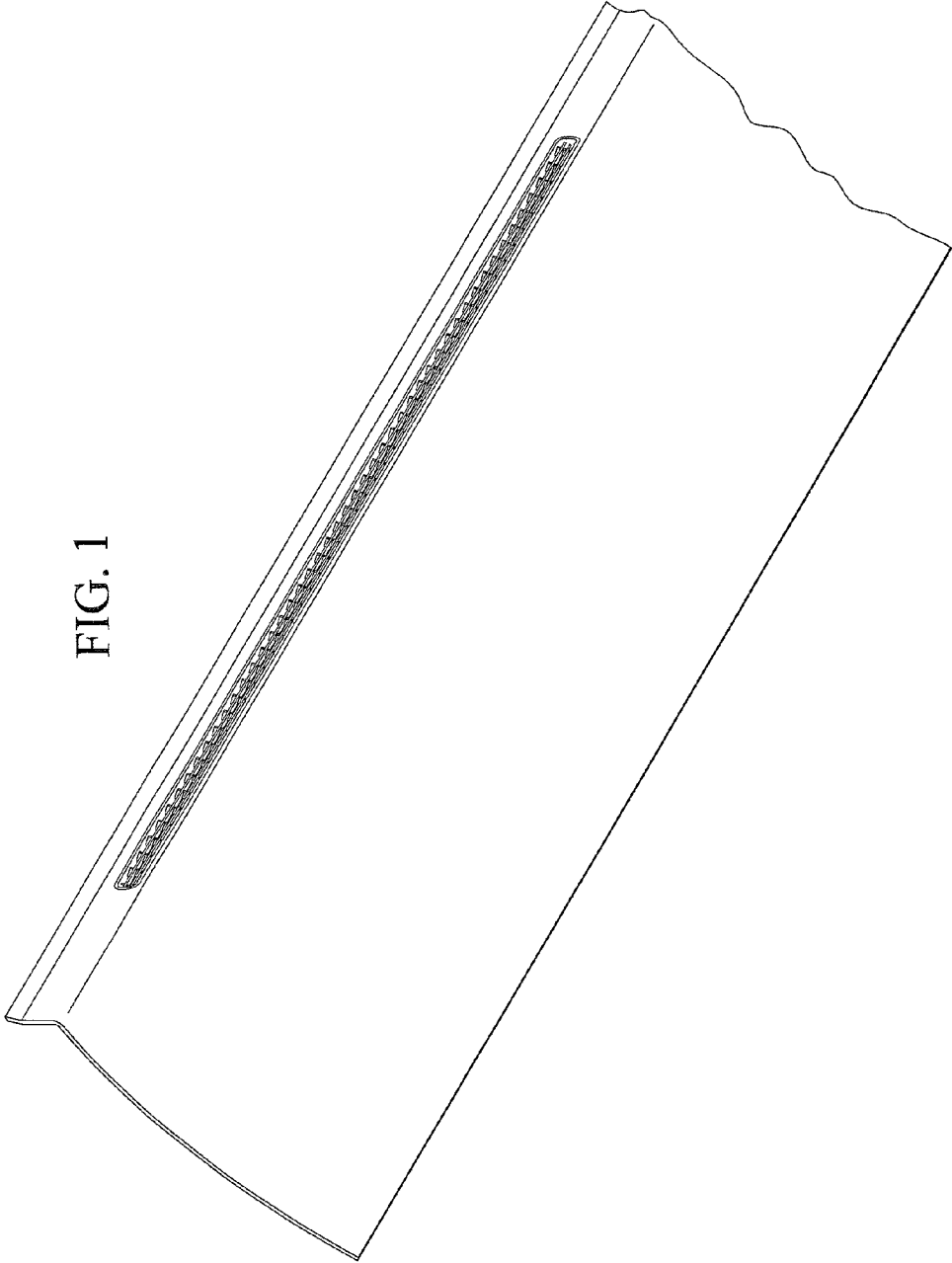

FIG. 2

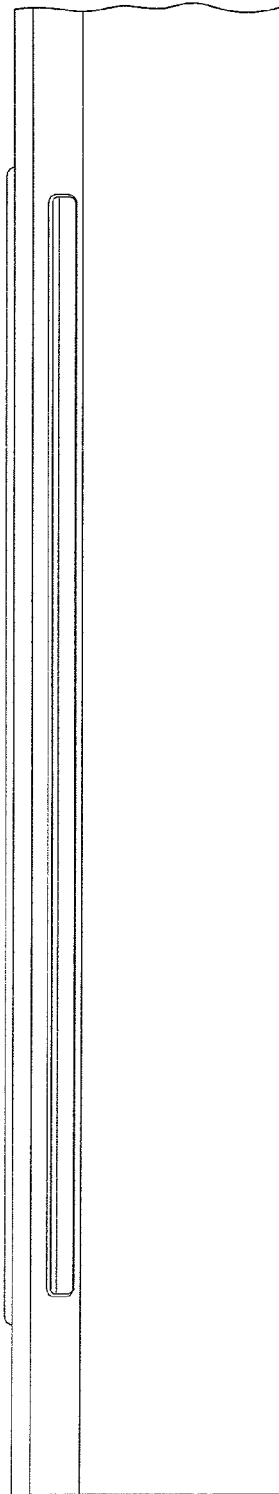

FIG. 3

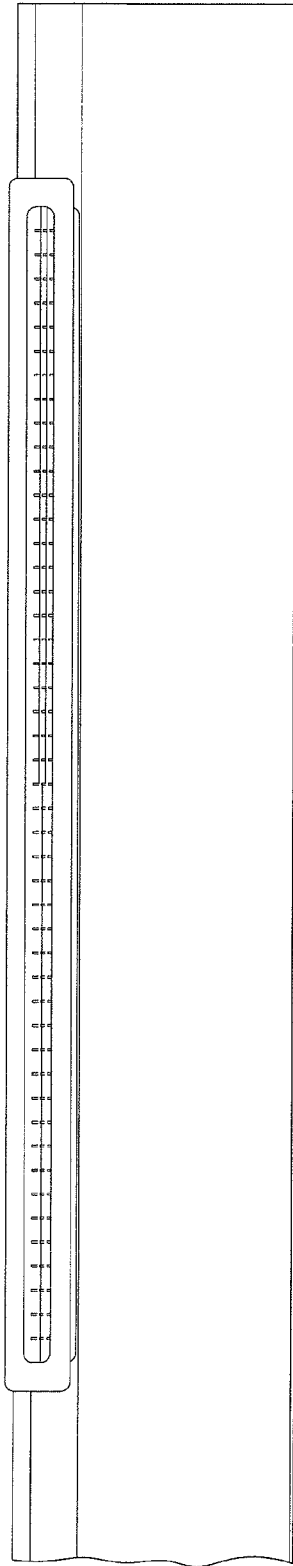

FIG. 4

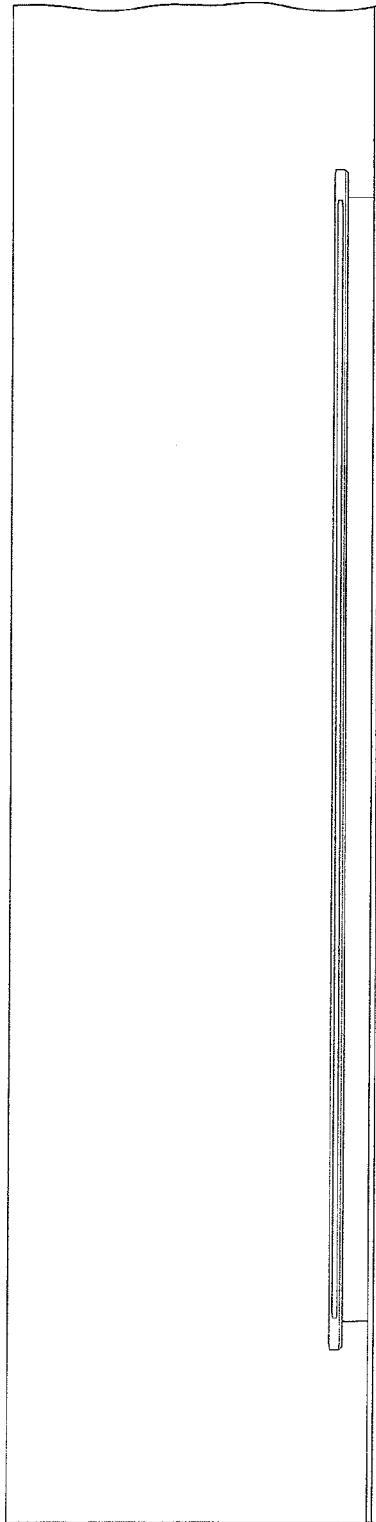

FIG. 5

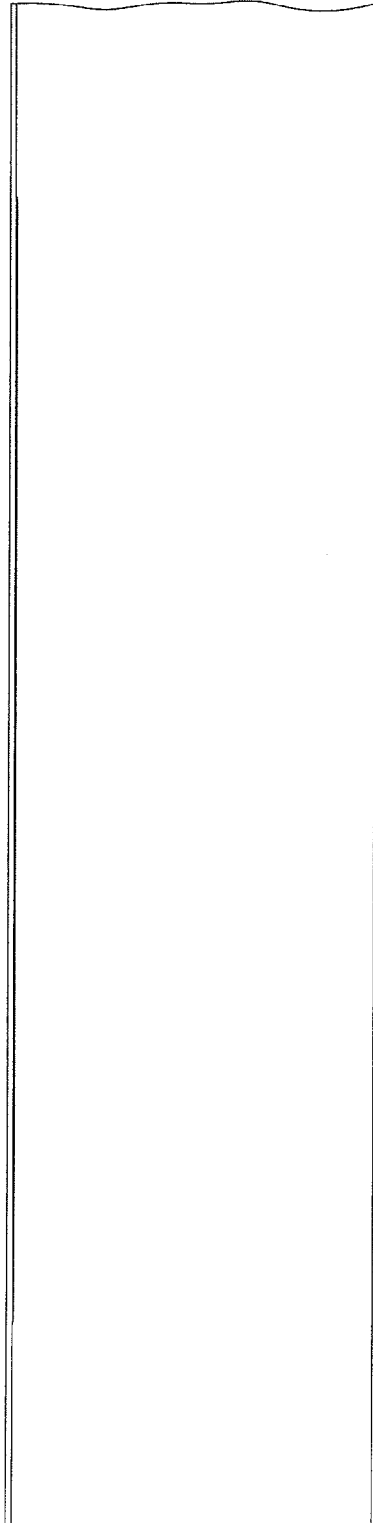

FIG. 7

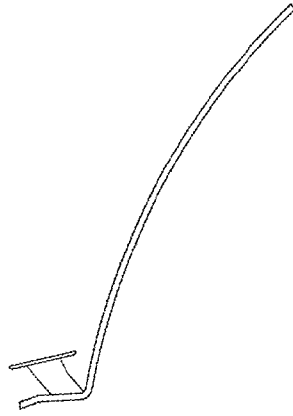

FIG. 6

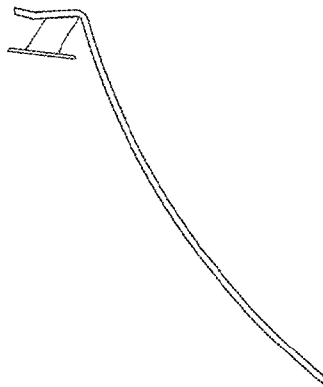



FIG. 8

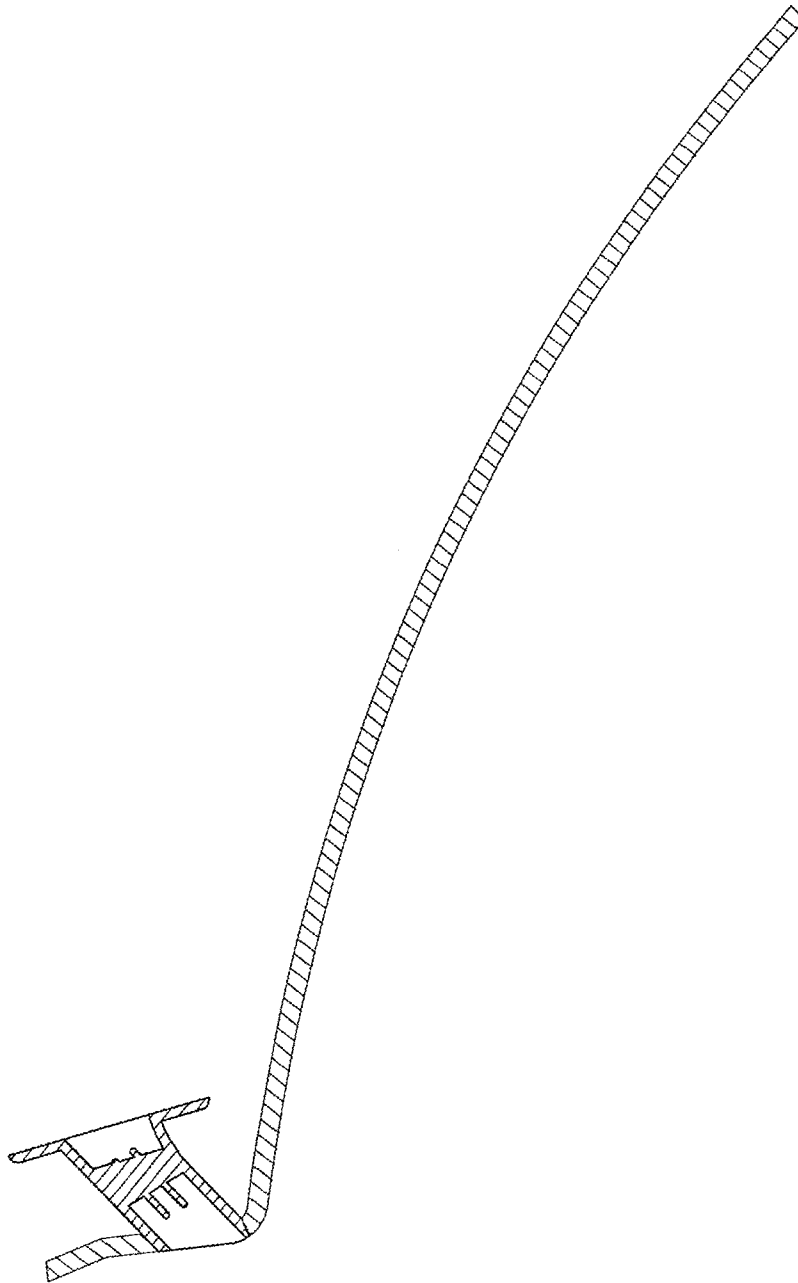

FIG. 9

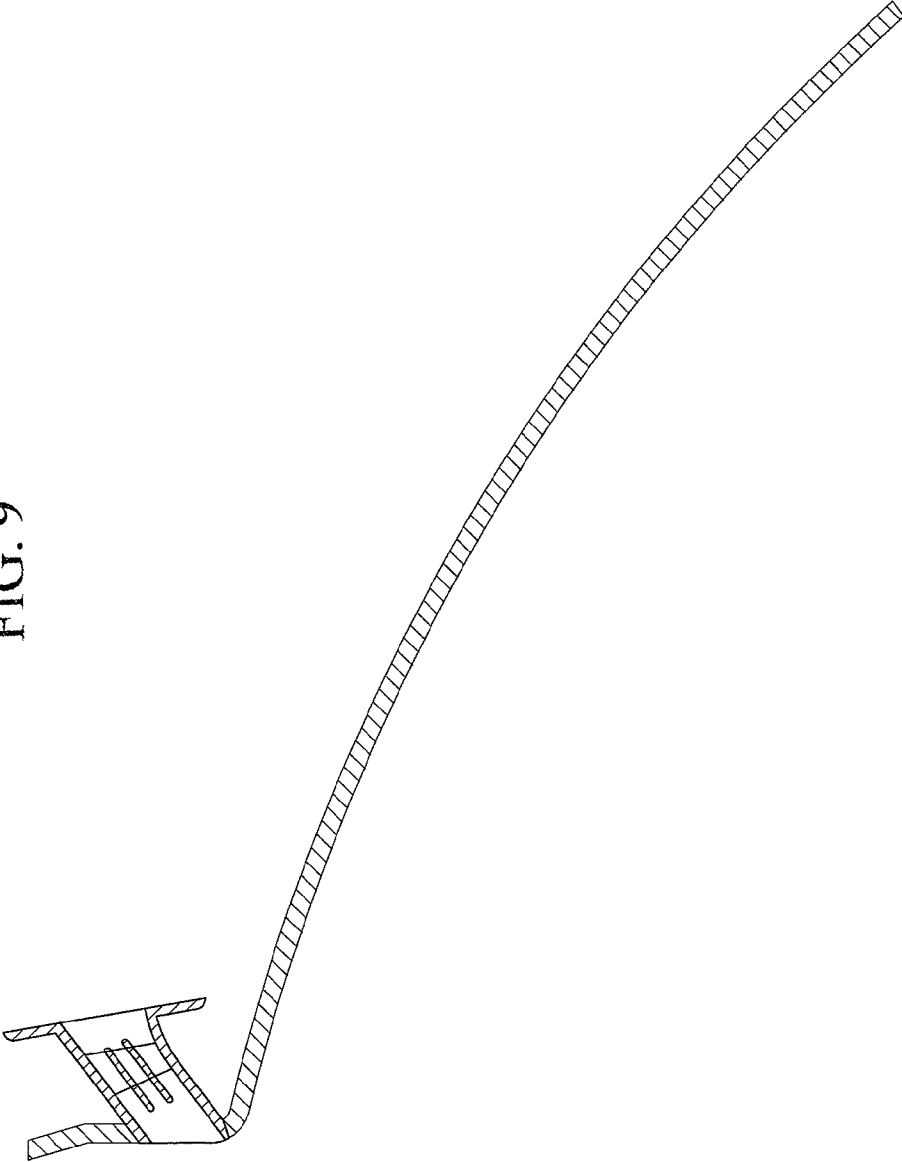

FIG. 10

