



US00D717979S

(12) **United States Design Patent**
Ueda et al.

(10) **Patent No.:** **US D717,979 S**

(45) **Date of Patent:** **** Nov. 18, 2014**

- (54) **HEADLAMP FOR A BICYCLE**
- (71) Applicants: **Takashi Ueda**, Osaka (JP); **Toshiyuki Nagano**, Osaka (JP)
- (72) Inventors: **Takashi Ueda**, Osaka (JP); **Toshiyuki Nagano**, Osaka (JP)
- (73) Assignee: **Cateye Co., Ltd.**, Higashisumiyoshi-Ku, Osaka-Shi, Osaka (JP)

D444,581 S *	7/2001	Okuda	D26/28
D498,550 S *	11/2004	Chen	D26/28
D514,239 S *	1/2006	Okuda	D26/28
D535,766 S	1/2007	Lee	
D540,481 S *	4/2007	Okuda	D26/28
D541,447 S *	4/2007	Ueda et al.	D26/28
D663,451 S	7/2012	Ueda	
D663,453 S *	7/2012	Nagano	D26/28

(**) Term: **14 Years**

(21) Appl. No.: **29/462,579**

(22) Filed: **Aug. 6, 2013**

(30) **Foreign Application Priority Data**

May 1, 2013 (JP) 2013-009825

(51) **LOC (10) Cl.** **26-06**

(52) **U.S. Cl.**
USPC **D26/28**

(58) **Field of Classification Search**
USPC D26/28-36; 362/459-468, 475-478,
362/485-487
See application file for complete search history.

(56) **References Cited**

U.S. PATENT DOCUMENTS

D441,107 S *	4/2001	Okuda	D26/28
D441,471 S *	5/2001	Nagano	D26/28

FOREIGN PATENT DOCUMENTS

JP	1274321	6/2006
JP	1451711	9/2012
TW	D144423	12/2011

* cited by examiner

Primary Examiner — Marcus Jackson

(74) *Attorney, Agent, or Firm* — Olson & Cepuritis, Ltd.

(57) **CLAIM**

The ornamental design for a headlamp for a bicycle, as shown.

DESCRIPTION

FIG. 1 is a perspective view of a headlamp for a bicycle showing our new design;
FIG. 2 is a front view thereof;
FIG. 3 is a rear view thereof;
FIG. 4 is a top plan view thereof;
FIG. 5 is a bottom plan view thereof;
FIG. 6 is a right side view thereof; and,
FIG. 7 is a left side view thereof.

1 Claim, 5 Drawing Sheets

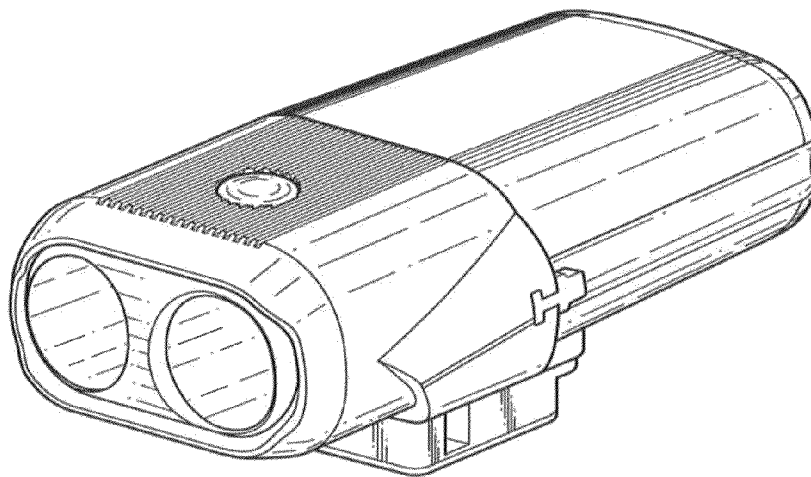

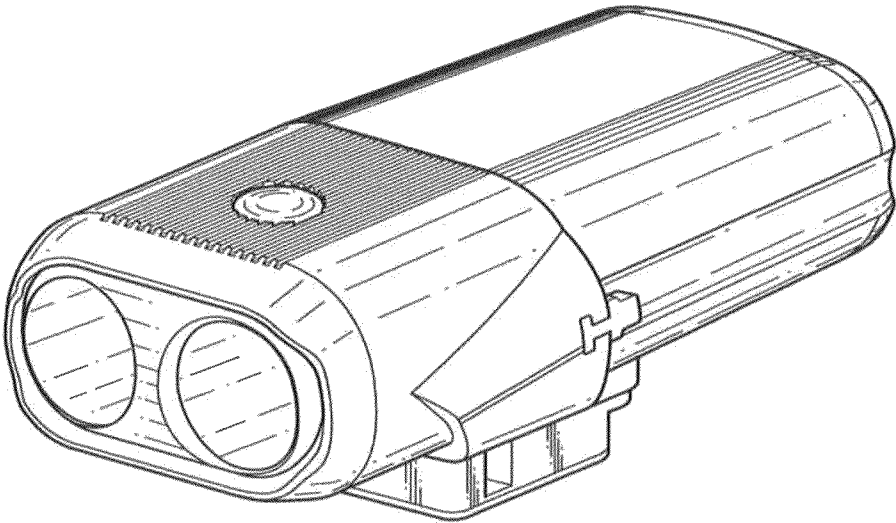

Fig. 1

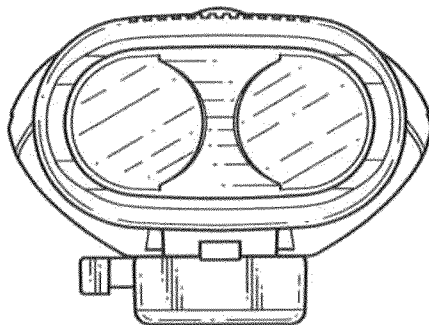

Fig. 2

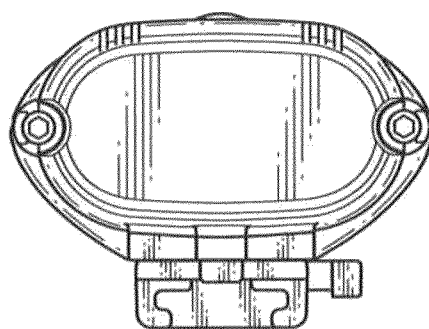

Fig. 3

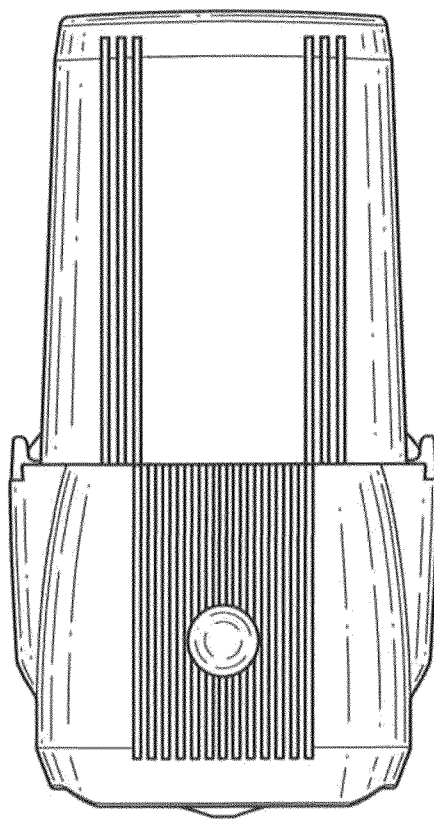

Fig. 4

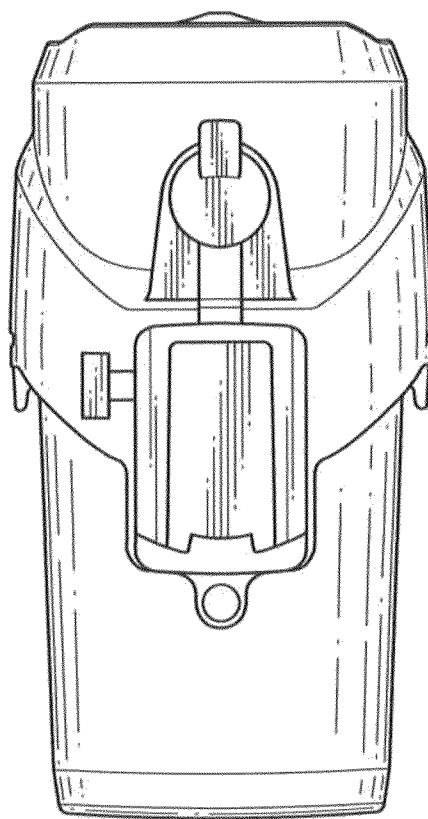

Fig. 5

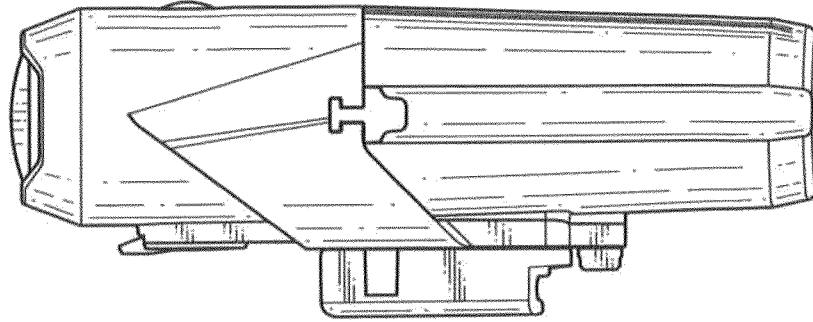

Fig. 6

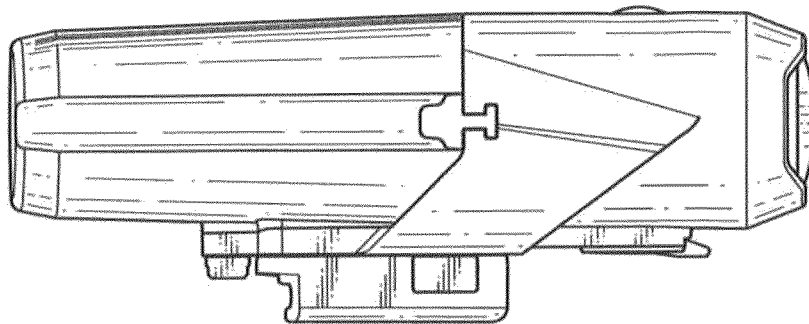

Fig. 7