

(19)  
(12)

(KR)  
(B1)

(51) 。 Int. Cl.<sup>7</sup>  
G02B 6/40

(45)  
(11)  
(24)

2003 10 30  
10-0403740  
2003 10 17

(21) 10-2001-0041451  
(22) 2001 07 11

(65)  
(43)

2003-0005942  
2003 01 23

(73) 3 416

(72) 119-3 103-1207

119-1 103-1203

(74)  
:

(54)

가 , V- ; V  
- ;  
가 , 가 가 , V-  
127 $\mu$ m 가 가 , V-

4

1  
2  
3

가

4  
 5  
 6  
 7  
 8 7 A-A  
 9  
 10 9 C  
 < 500 : 510 : >  
 530 : V- 600 :  
 610 : 700 :

/ (PLC : Planer Lightwave Circuit)

(WDM : Wavelength Division Multiplexing)

N 가

(AWG)

가

1  
 20, 130) , (135, 135a) , (110) (quartz) (140) , (100, 100a) (141) (1  
 (core) (clad)  
 ) (120, 130) (120) (130) (130) (141)  
 (140)  
 2  
 2 3 (130) (140) (131) (141)  
 V- (132) V- (132) (140), (141)가 (135) (141)  
 V- (132) (131) (140) (141)  
 가 , (136) (140) (141)  
 , 8 12 V- 500μm V- 250μm ,  
 , V- 가 , 가 , 가  
 , 가 , V- 가

V-

127 $\mu$ m V-

V-

가 가

5 8 (500) (610)가  
 V- (530) (520) (520)  
 (560) (510) V- (530) (610)  
 (600) (610) (520) (7

00)  
 4 6 (500) (510)  
 V- (530) (520) (520)  
 (610)가 (520) (550) 가  
 (560) V- (530) (531) (533)  
 (533) (531) (533) (520) (560) (550) (531)  
 (610)가 V- (530) (600) (bending) (531)  
 가 (500) (510) V- (530) 127 $\mu$ m  
 250 $\mu$ m 500 $\mu$ m V- (530) (5)  
 31) (533) (532) (610) (610) V-  
 (530) (610) (610) (610)

9 10 가 (600) (500) V- (530)  
 (610) 가 V- 250 $\mu$ m 500 $\mu$ m 127 $\mu$ m (600)  
 (600) (620) 가

, 가 (610) (610)가 (510)  
 4 7 8 (700) (610)가 (700)  
 510) (520) (610) (700)  
 (610)가 (710) (B) (700) (750)  
 (755) (510) (700)

127 $\mu$ m V- 가  
 127 $\mu$ m가 가 V- 가  
 가 가 가

(57)

1.

V- ; , 가  
V- ;  
가 가

2.

1 , ,

3.

2 , ,

4. 가

1

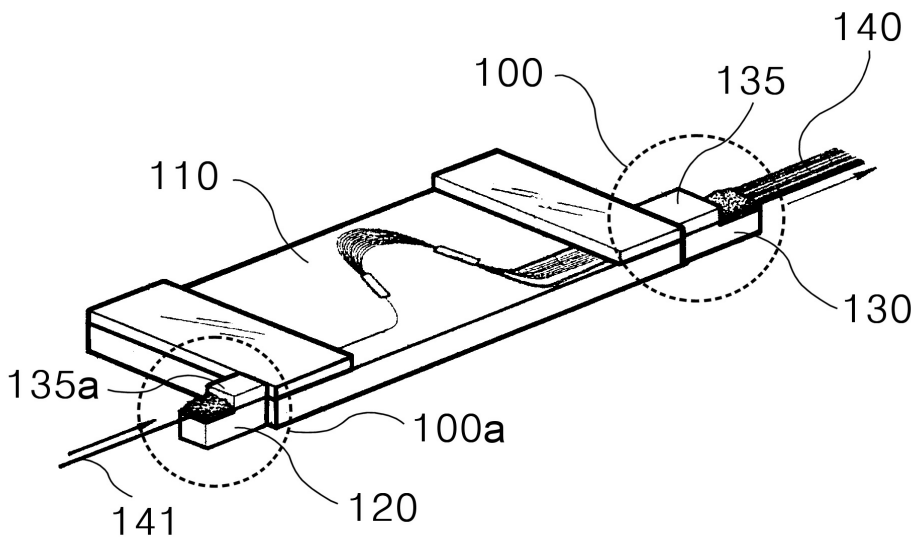

2

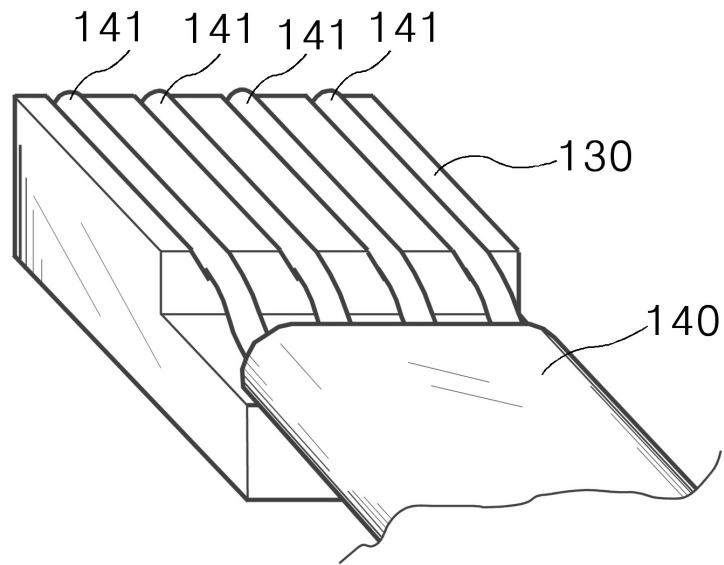

3

130

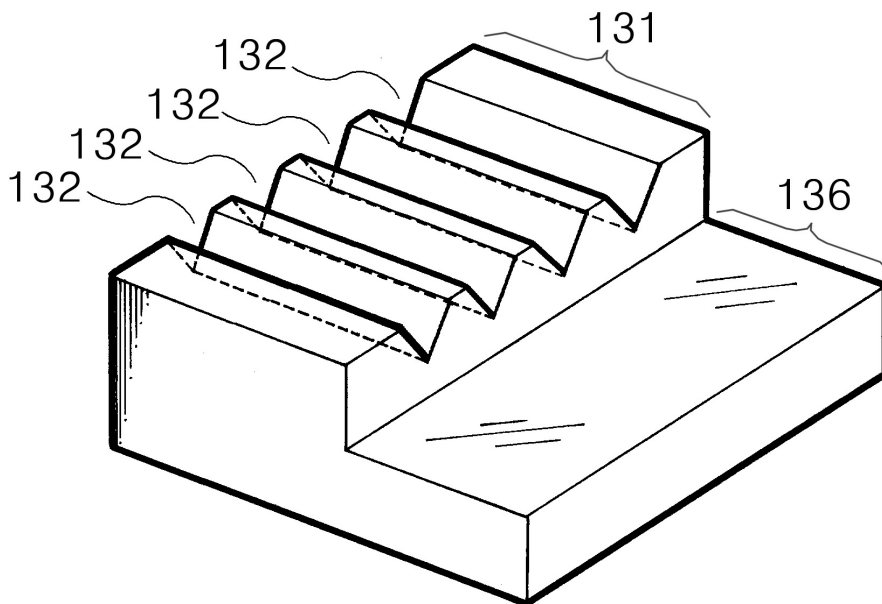

4

500

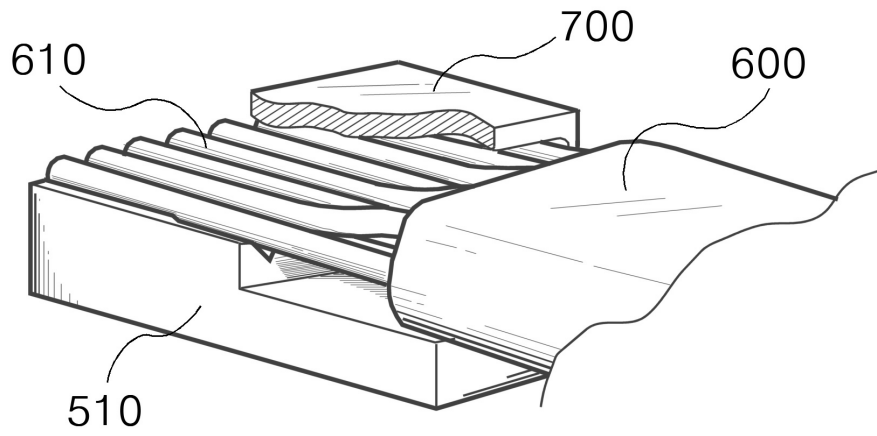

5

510

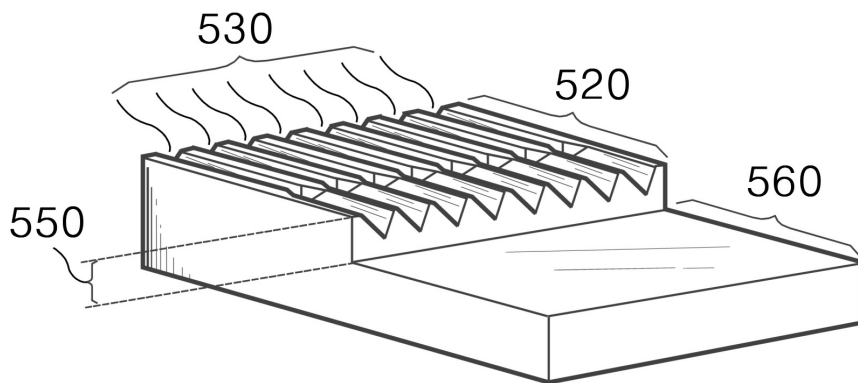

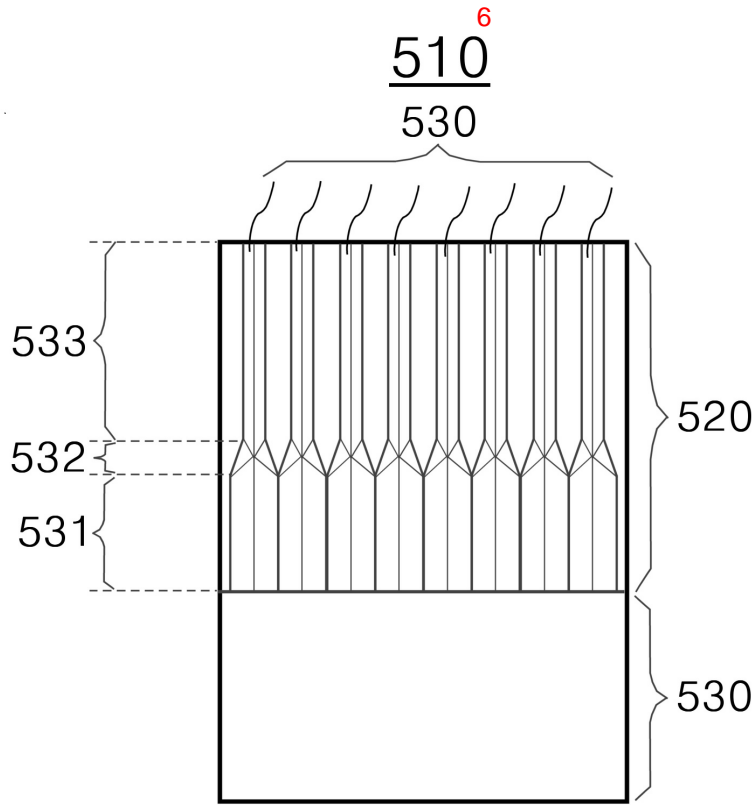

7

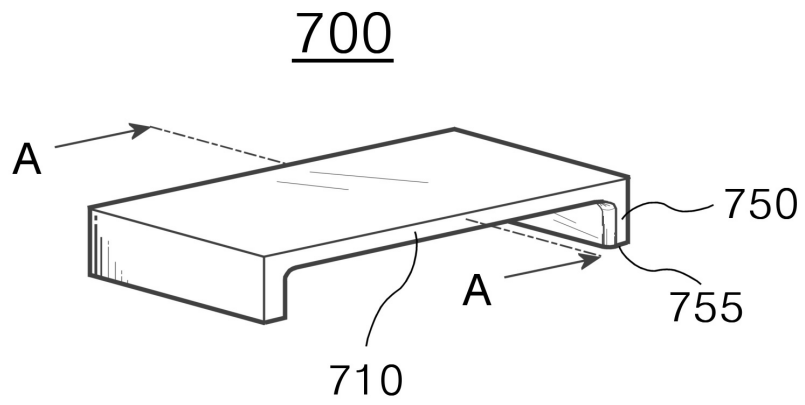

8

700

**A-A**

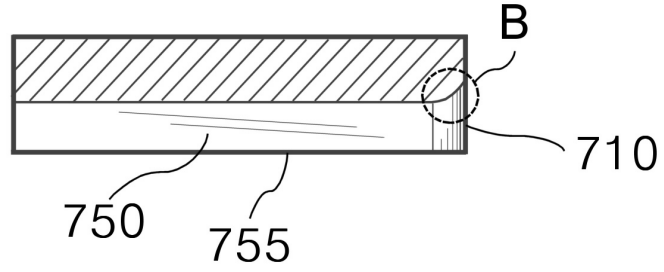

9

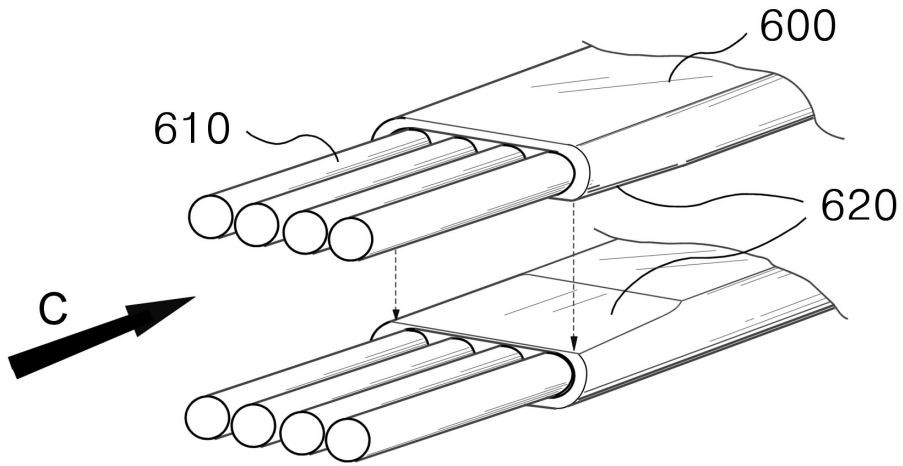



10

