



US00D604458S

(12) **United States Design Patent**
Kato et al.

(10) **Patent No.:** **US D604,458 S**

(45) **Date of Patent:** **** Nov. 17, 2009**

(54) **HAND DRYER**

(75) Inventors: **Hiroyuki Kato**, Tokyo (JP); **Kei Kasuga**, Tokyo (JP)

(73) Assignee: **Mitsubishi Electric Corporation**, Tokyo (JP)

(**) Term: **14 Years**

(21) Appl. No.: **29/317,978**

(22) Filed: **May 12, 2008**

(30) **Foreign Application Priority Data**

Nov. 13, 2007	(JP)	2007-031351
Nov. 13, 2007	(JP)	2007-031352
Nov. 13, 2007	(JP)	2007-031353
Nov. 13, 2007	(JP)	2007-031354

(51) **LOC (9) Cl.** **28-03**

(52) **U.S. Cl.** **D28/54.1**

(58) **Field of Classification Search** D28/12,
D28/54.1, 58; 34/266, 201, 202; 392/381,
392/380; D23/357, 361, 385

See application file for complete search history.

(56) **References Cited**

U.S. PATENT DOCUMENTS

4,206,556	A *	6/1980	Sabo et al.	34/90
D277,322	S *	1/1985	West	D28/58
D279,412	S *	6/1985	Fung	D28/58
D286,211	S *	10/1986	Zinbarg et al.	D28/58
D287,297	S *	12/1986	Reid et al.	D28/12
D292,326	S *	10/1987	Maass	D28/12
D294,740	S *	3/1988	Yonezawa et al.	D28/12
4,754,769	A *	7/1988	Flynn	132/73.5
D299,174	S *	12/1988	Shoemaker	D28/58
D326,511	S *	5/1992	Chiang	D23/328

FOREIGN PATENT DOCUMENTS

IN	218362	5/2008
IN	218363	5/2008

* cited by examiner

Primary Examiner—Janice E Seeger
Assistant Examiner—Zenia I Bennett
(74) *Attorney, Agent, or Firm*—Sughrue Mion, PLLC

(57) **CLAIM**

The ornamental design for a hand dryer, as shown and described.

DESCRIPTION

FIG. 1 is a front perspective view of a hand dryer according to a first embodiment of the invention;

FIG. 2 is a front view thereof;

FIG. 3 is a rear view thereof;

FIG. 4 is a first side view thereof;

FIG. 5 is a second side view thereof;

FIG. 6 is a top view thereof;

FIG. 7 is a bottom view thereof;

FIG. 8 is a front perspective view of a hand dryer according to a second embodiment of the invention;

FIG. 9 is a front view thereof;

FIG. 10 is a rear view thereof;

FIG. 11 is a first side view thereof;

FIG. 12 is a second side view thereof;

FIG. 13 is a top view thereof;

FIG. 14 is a bottom view thereof;

FIG. 15 is a front perspective view of a hand dryer according to a third embodiment of the invention;

FIG. 16 is a front view thereof;

FIG. 17 is a rear view thereof;

FIG. 18 is a side view thereof;

FIG. 19 is a second side view thereof;

FIG. 20 is a top view thereof; and,

FIG. 21 is a bottom view thereof.

The broken lines are for environmental purposes only and form no part of the claimed design.

1 Claim, 21 Drawing Sheets

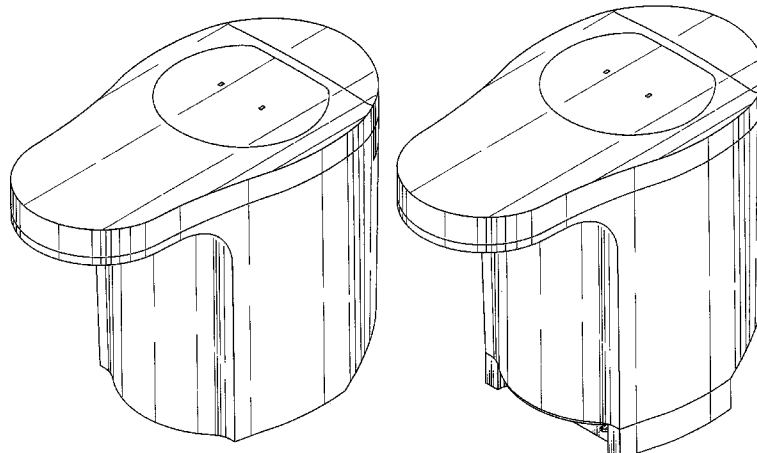

FIG.1

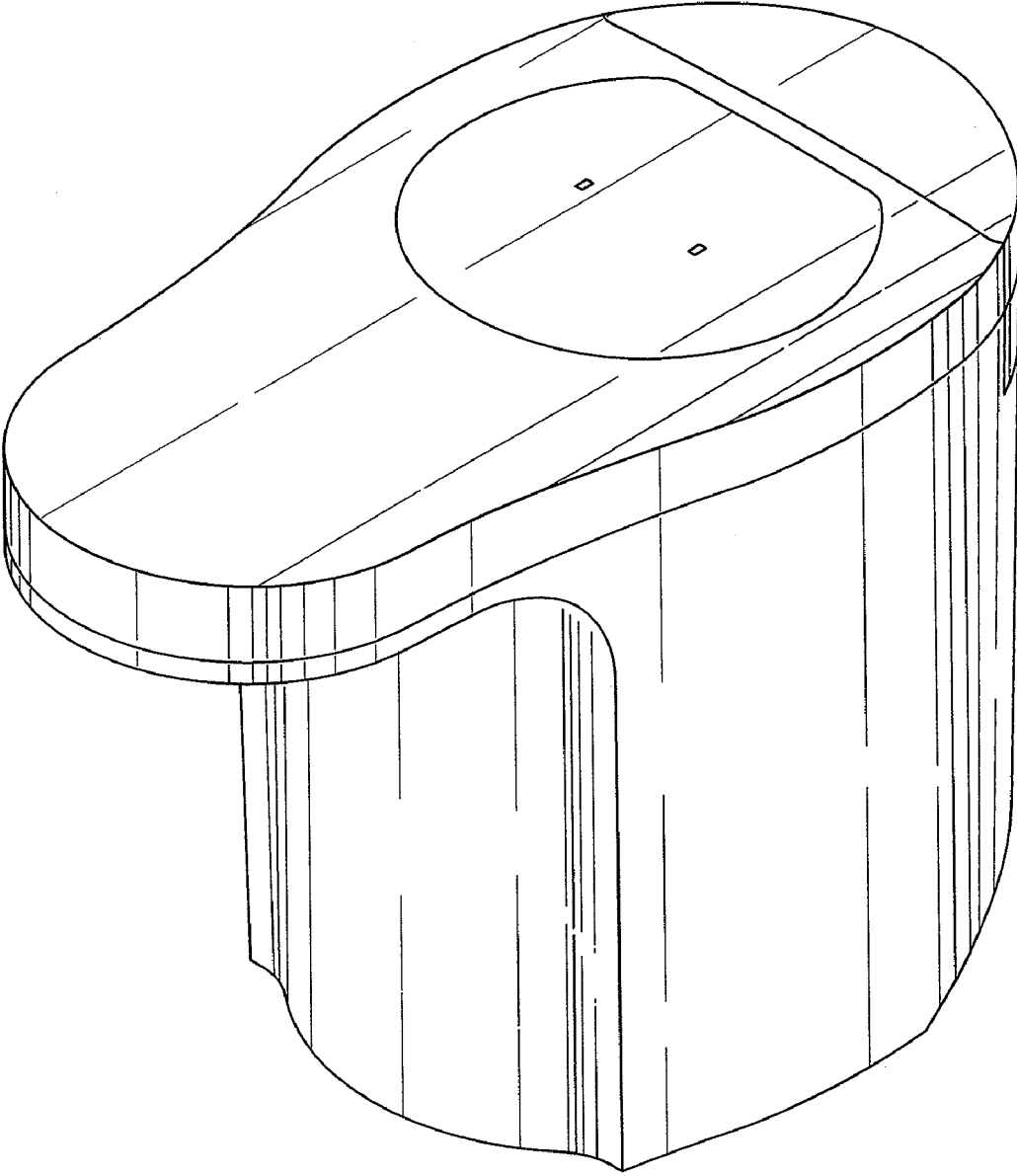

FIG.2

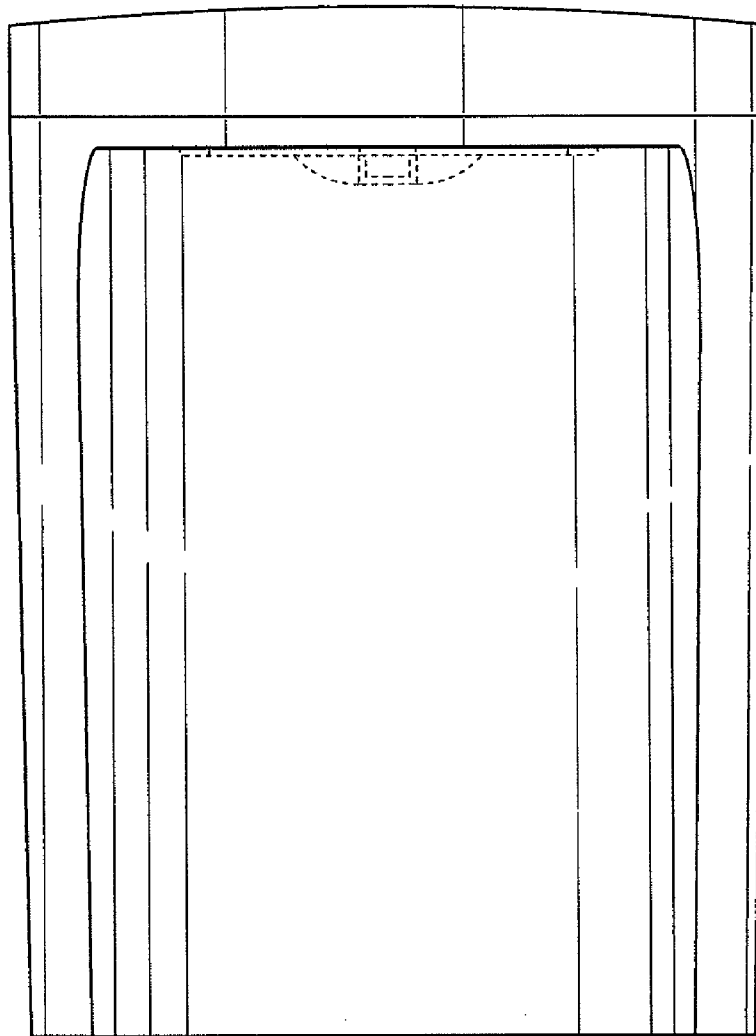

FIG.3

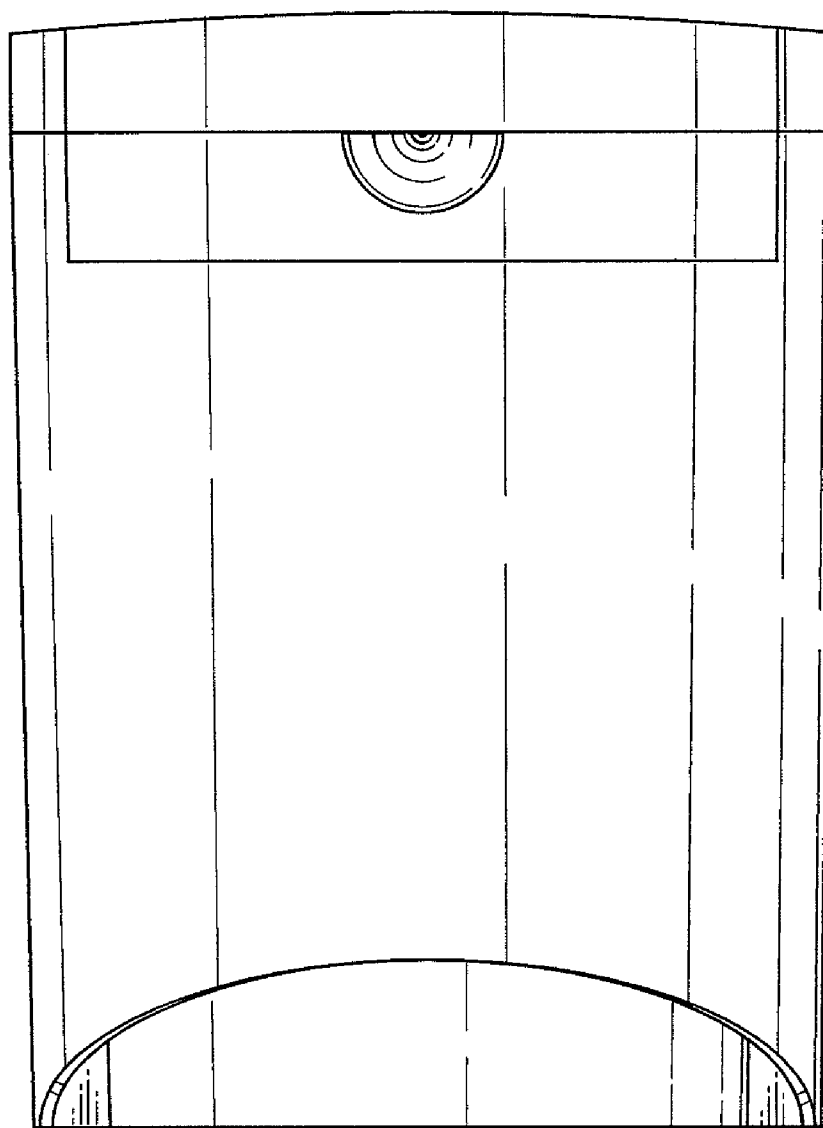

FIG.4

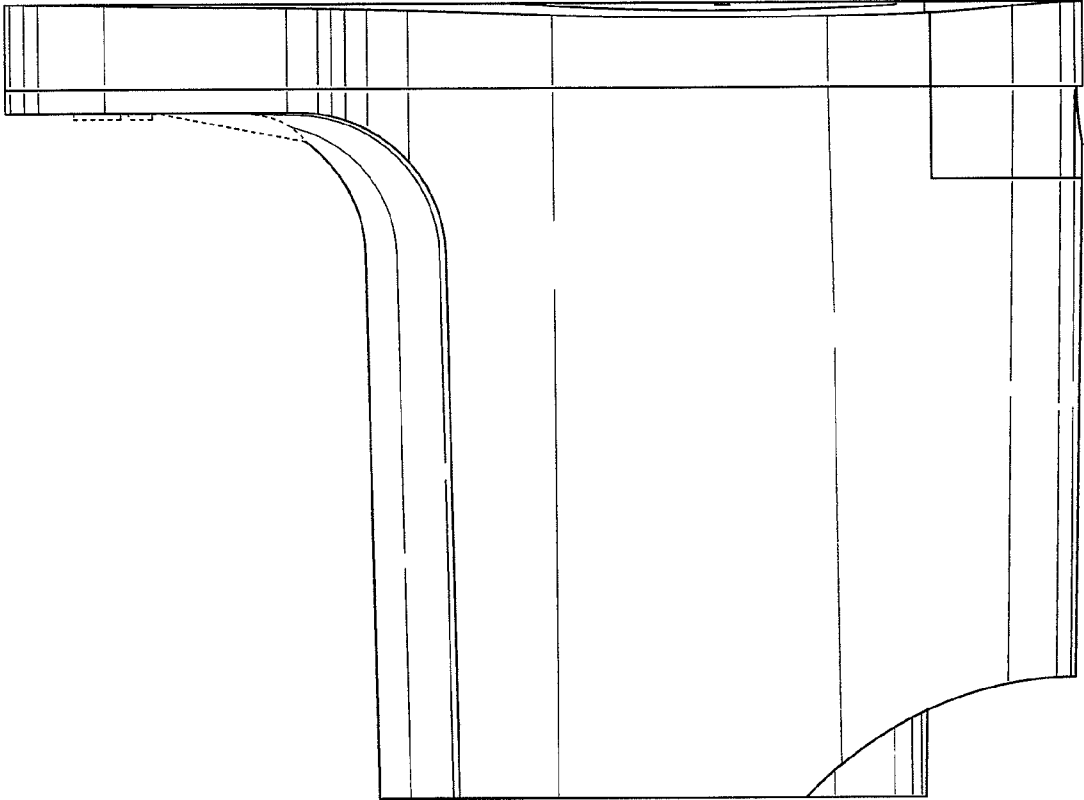

FIG.5

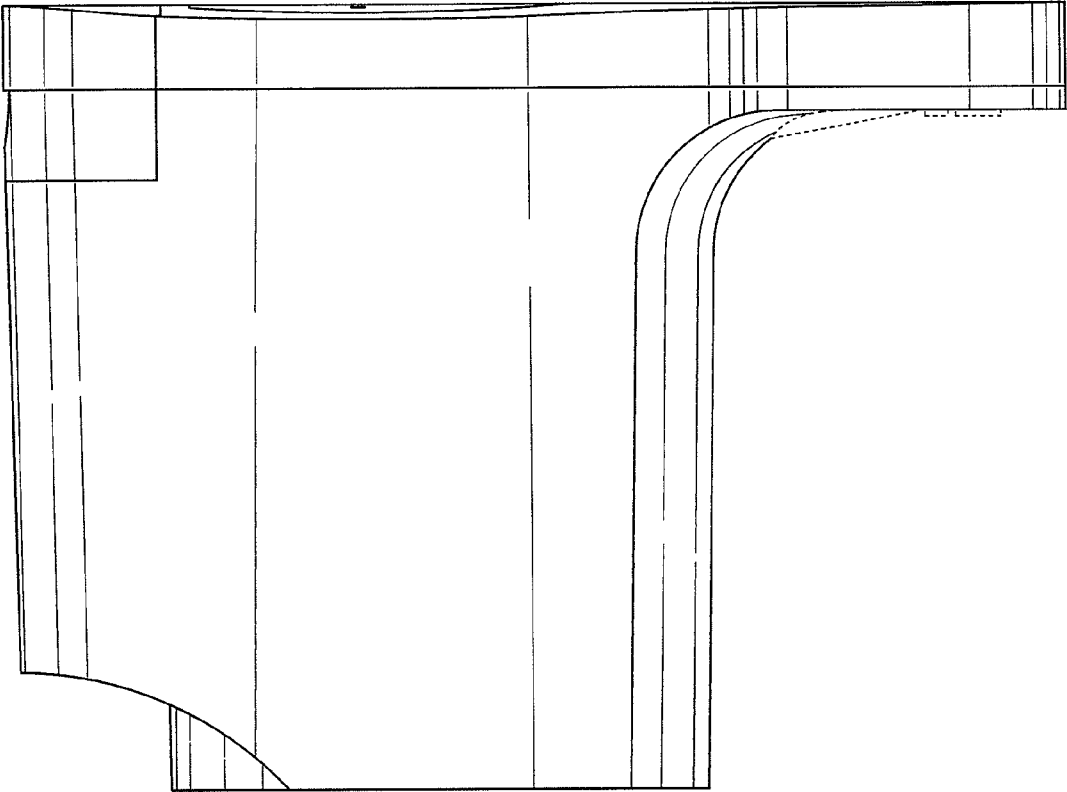

FIG.6

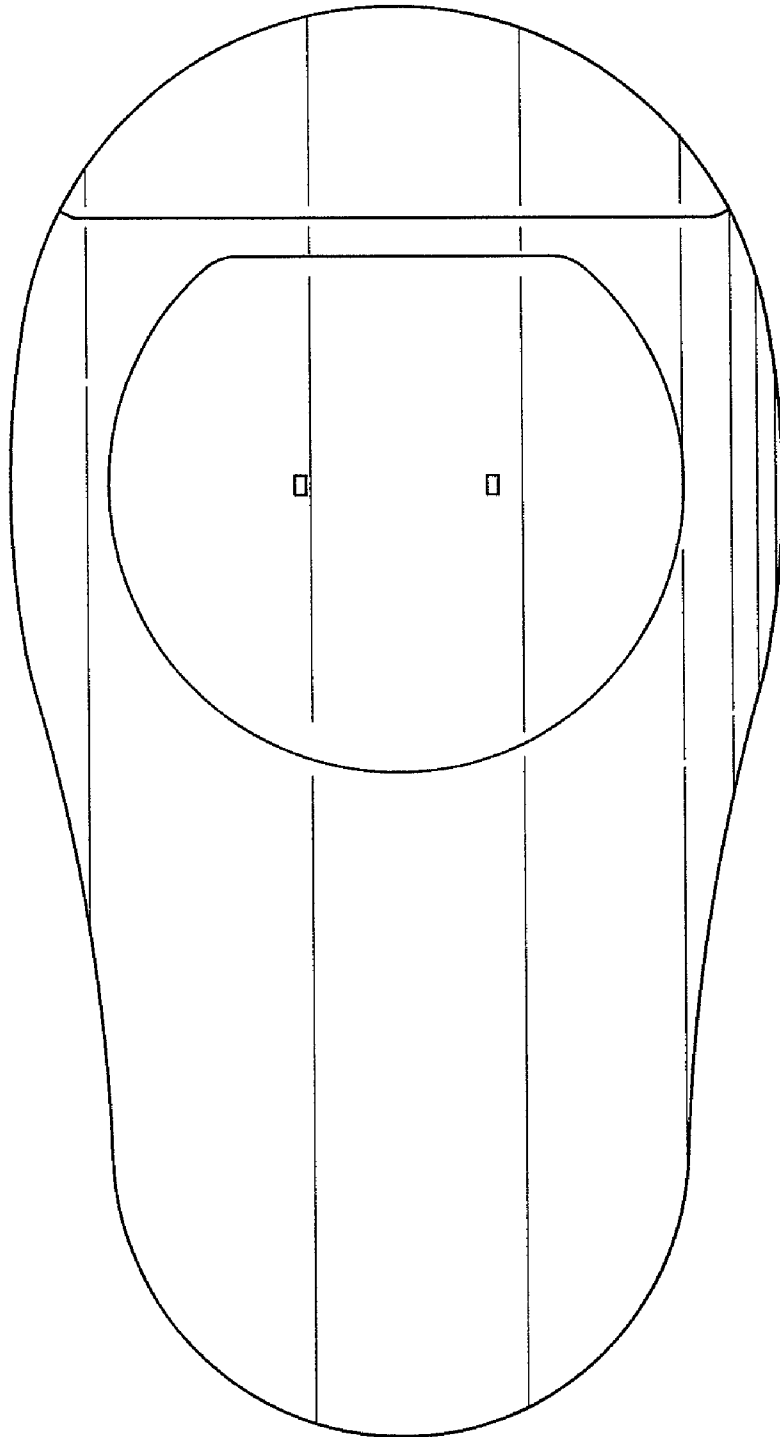

FIG. 7

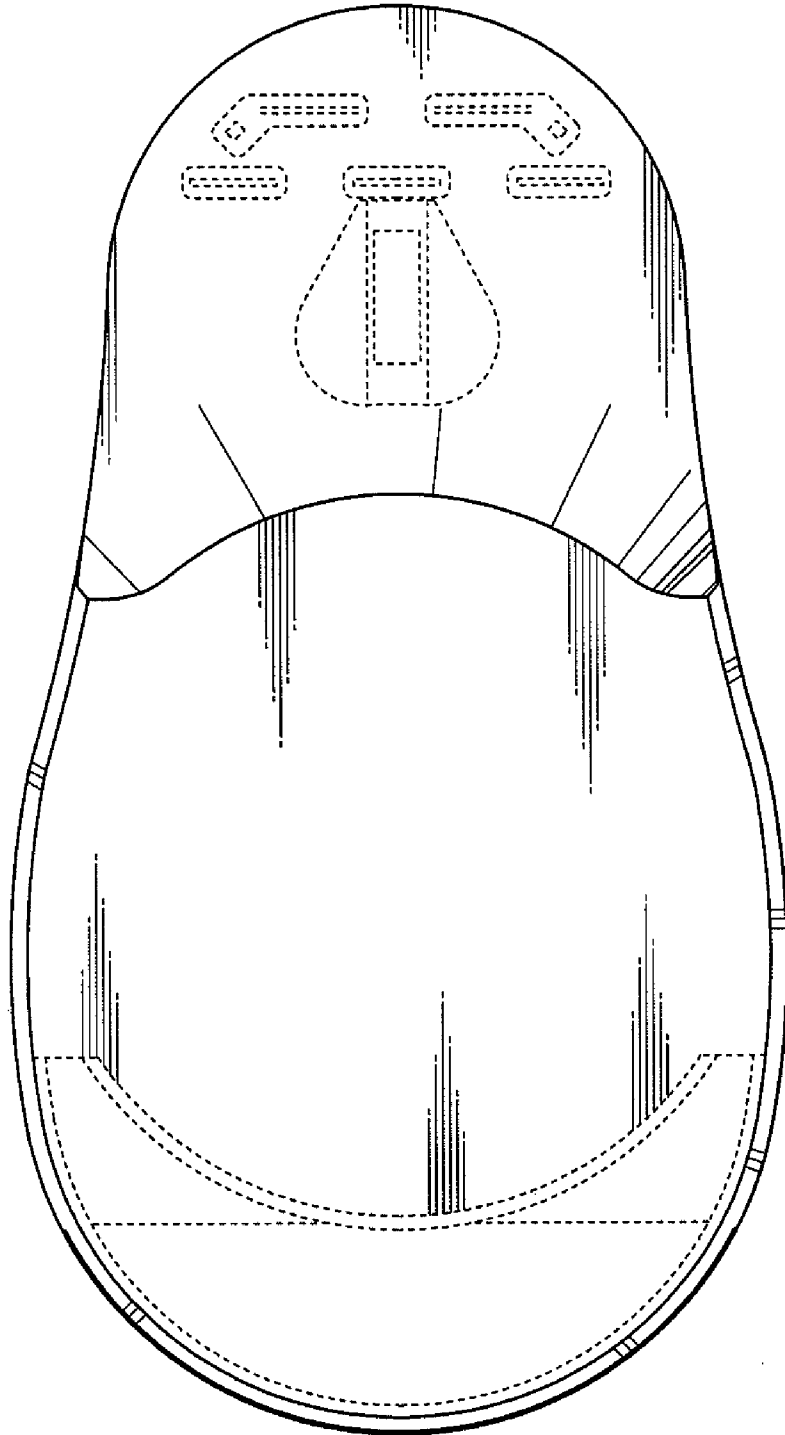

FIG.8

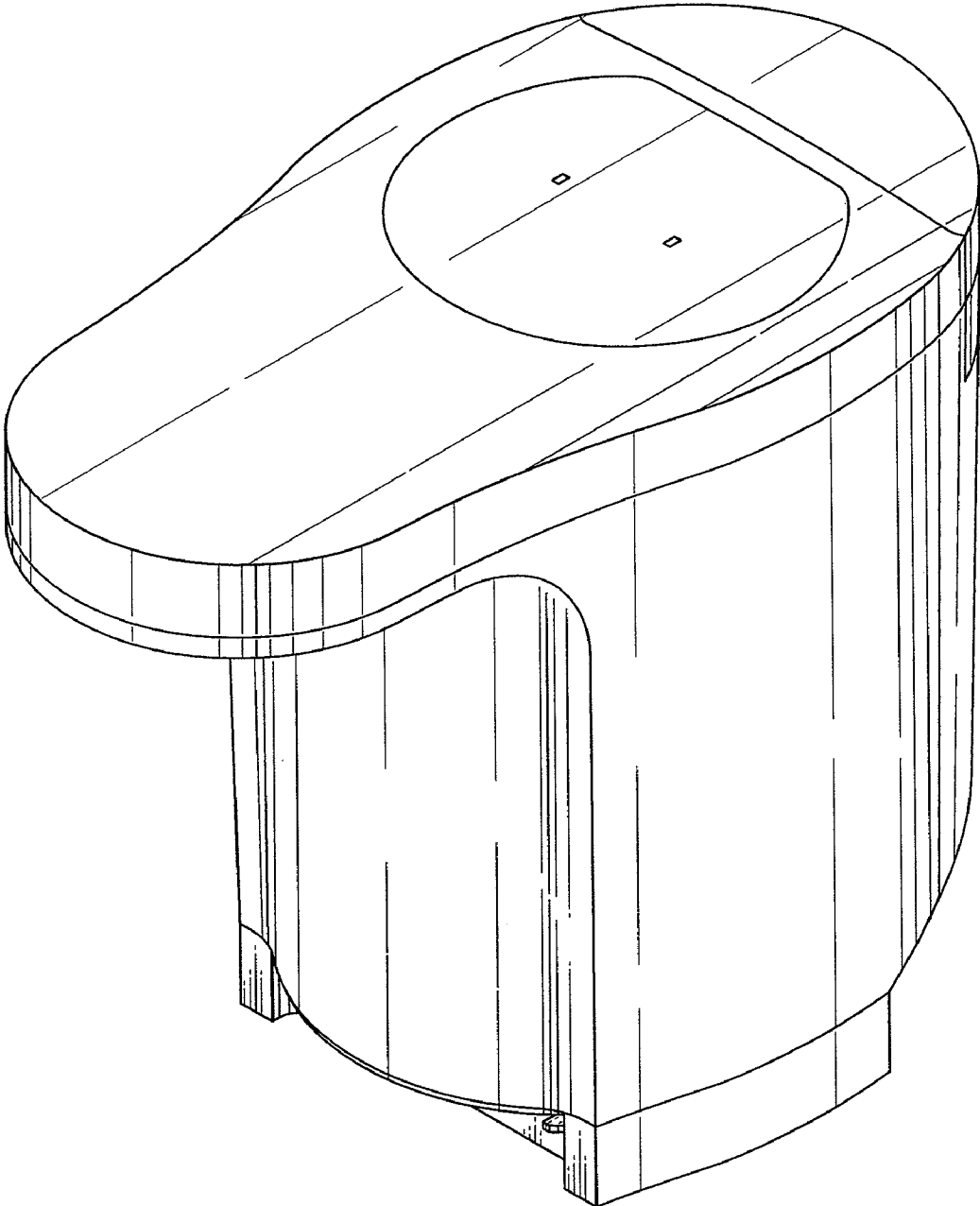

FIG.9

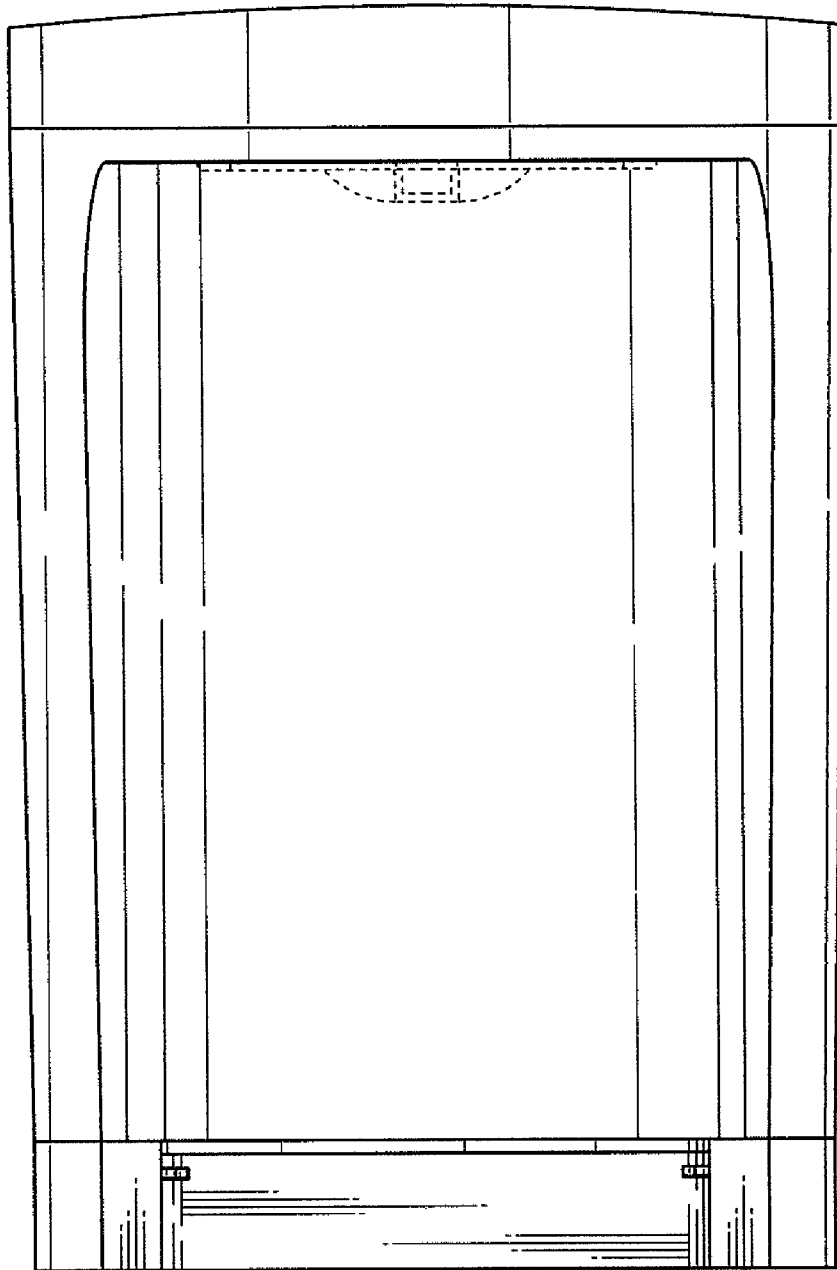

FIG.10

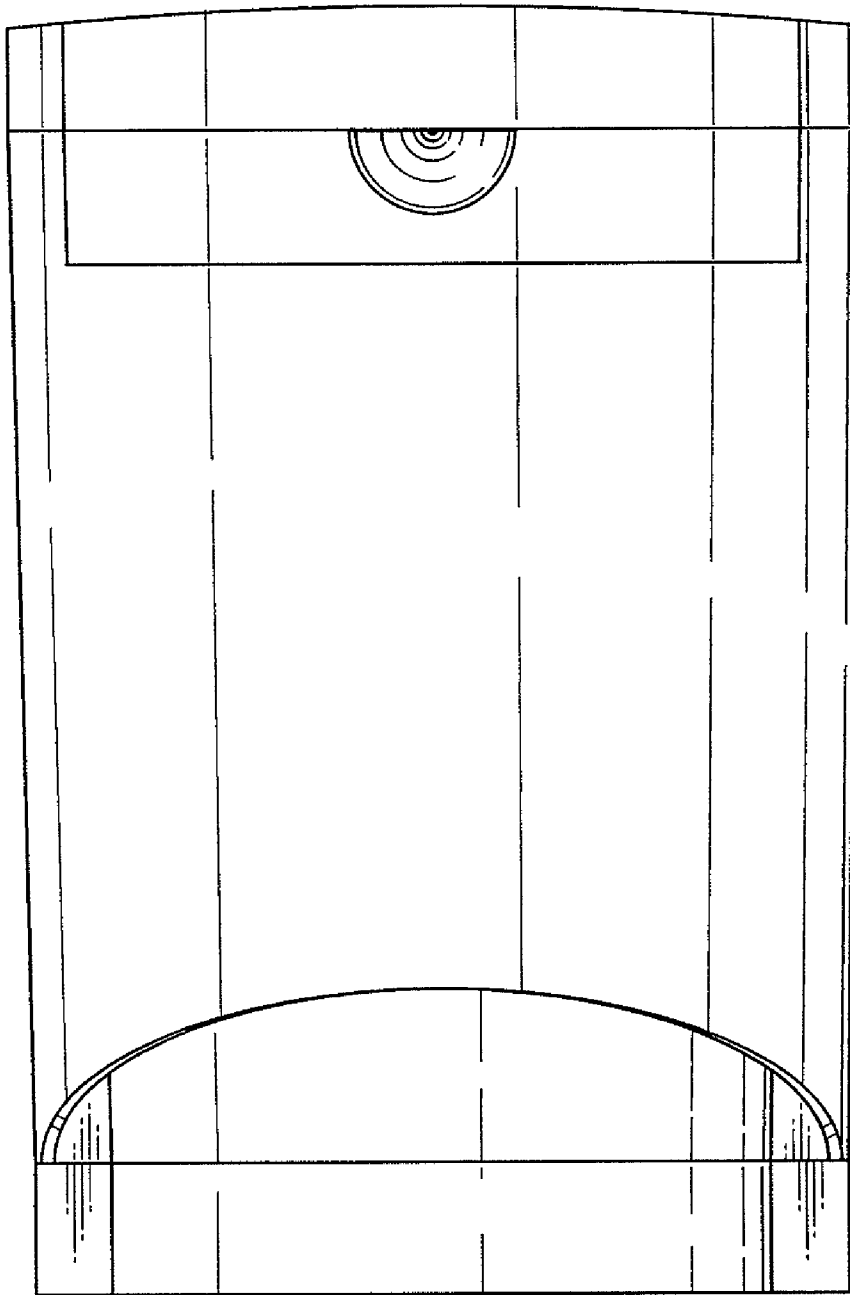

FIG.11

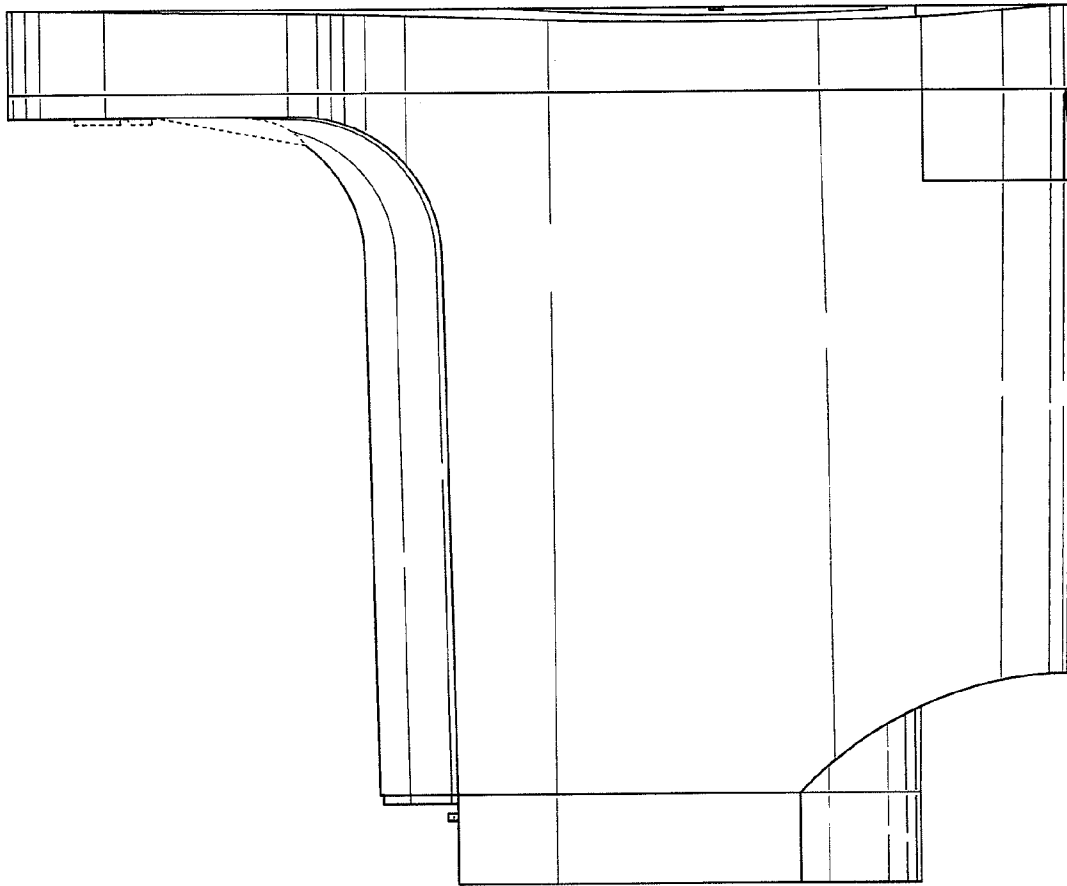

FIG.12

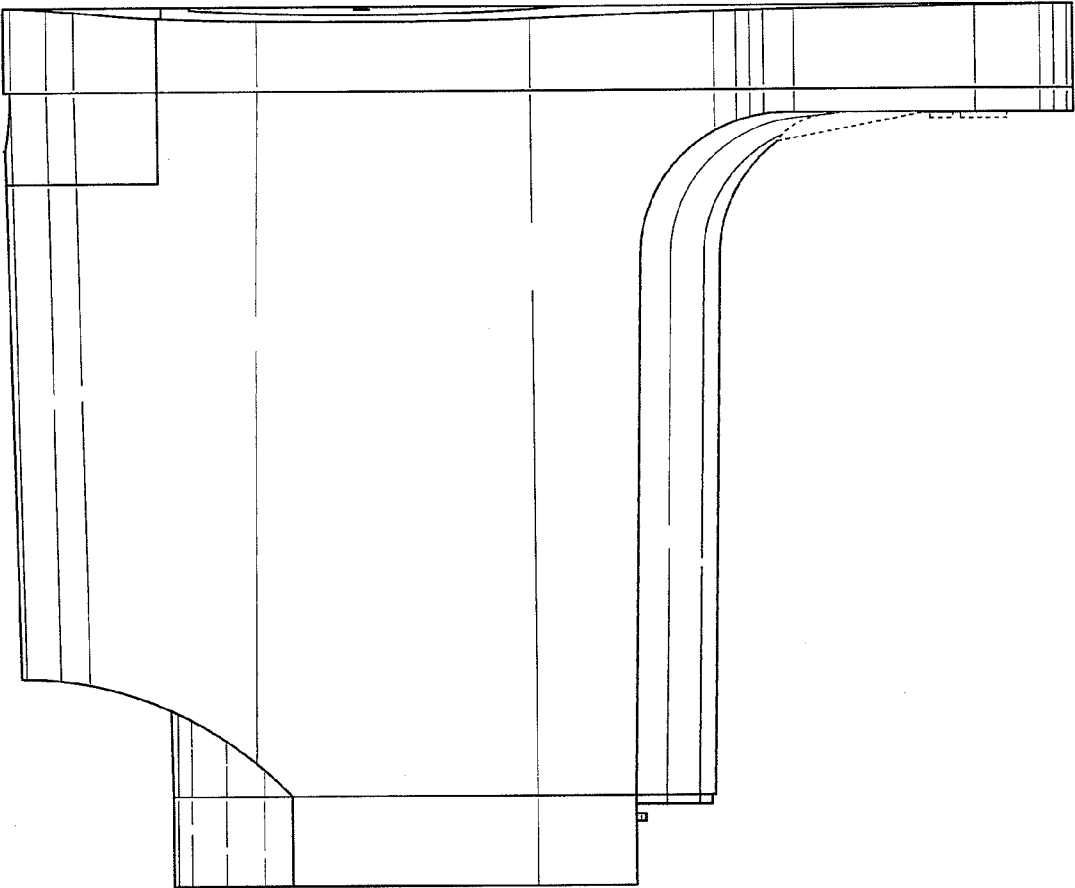

FIG.13

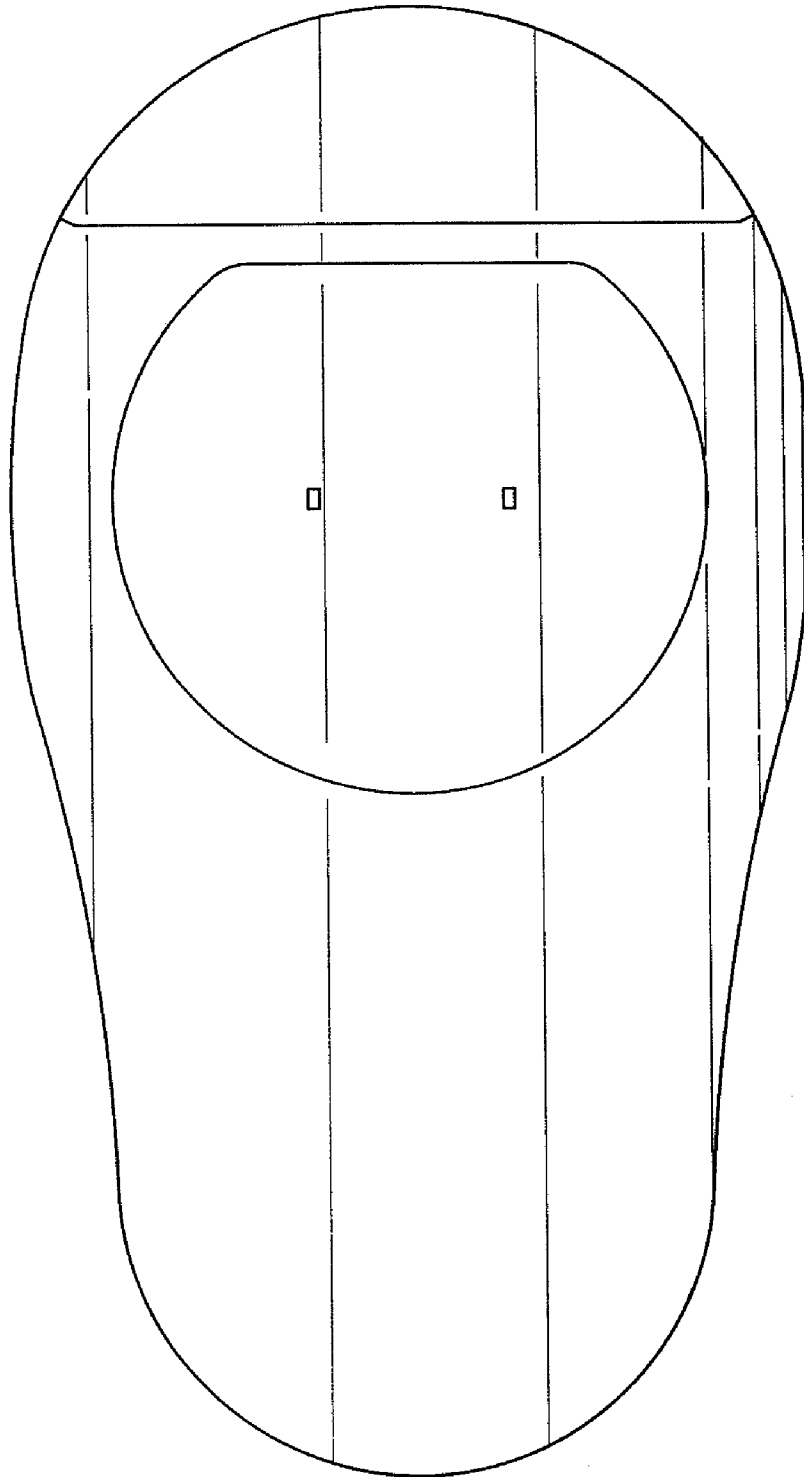

FIG. 14

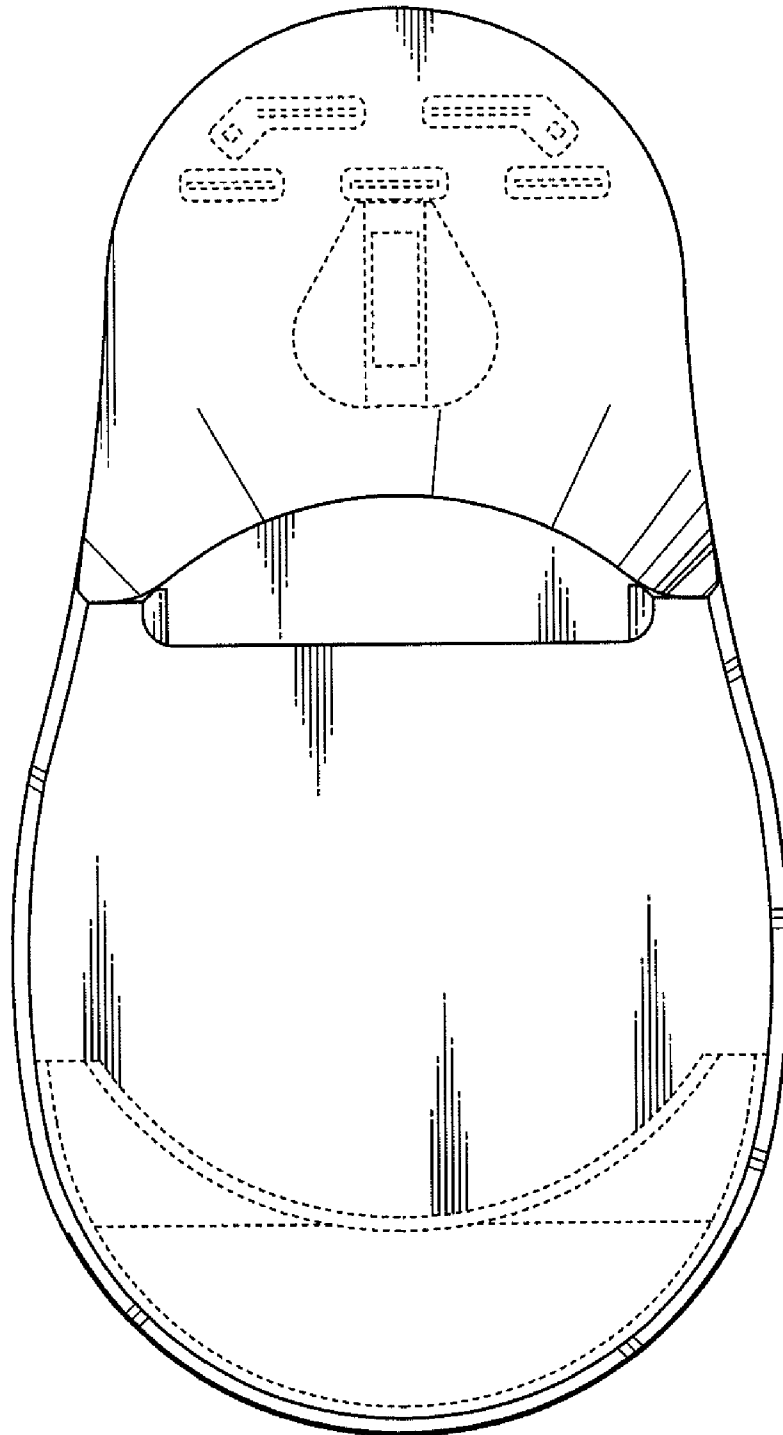

FIG.15

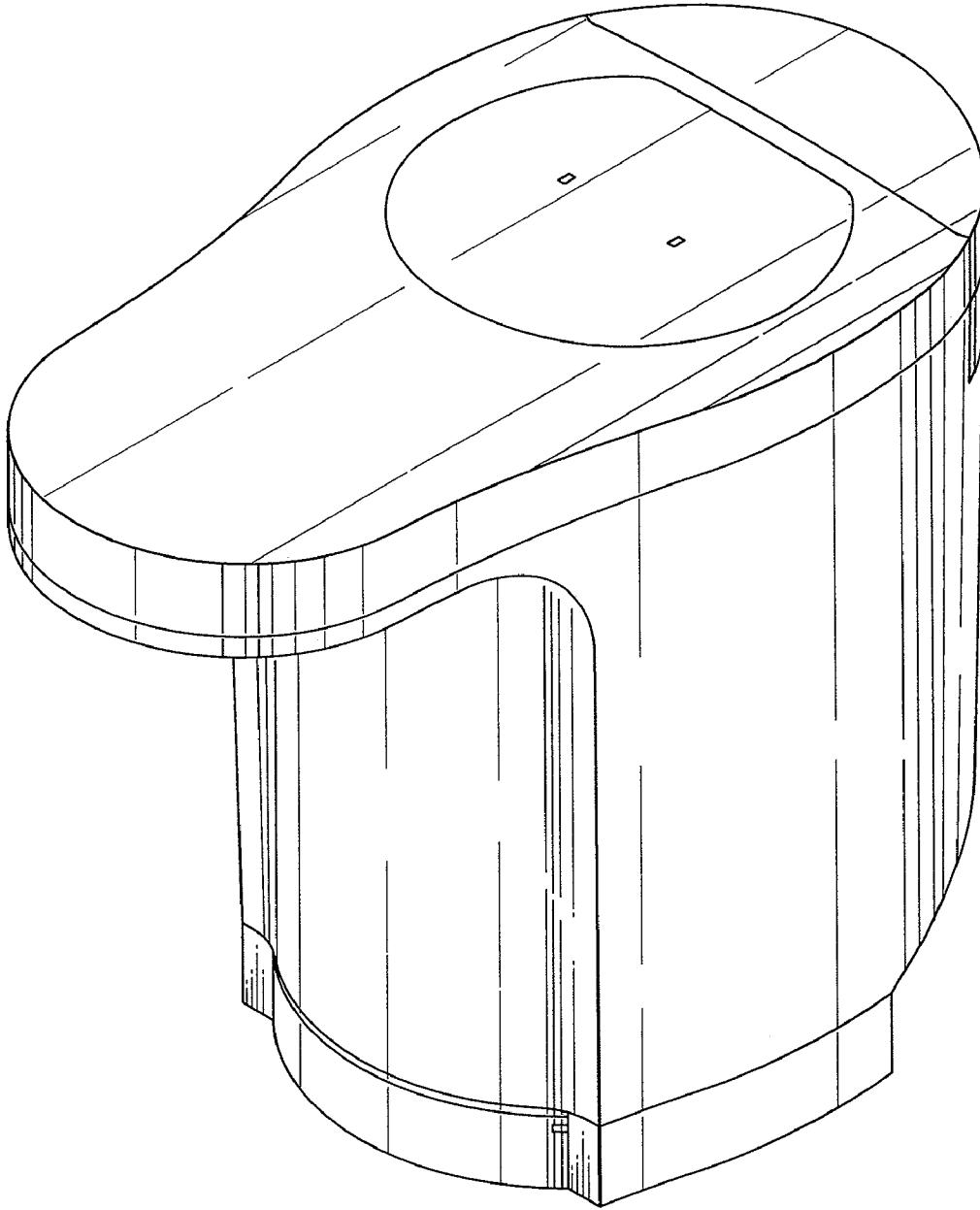

FIG. 16

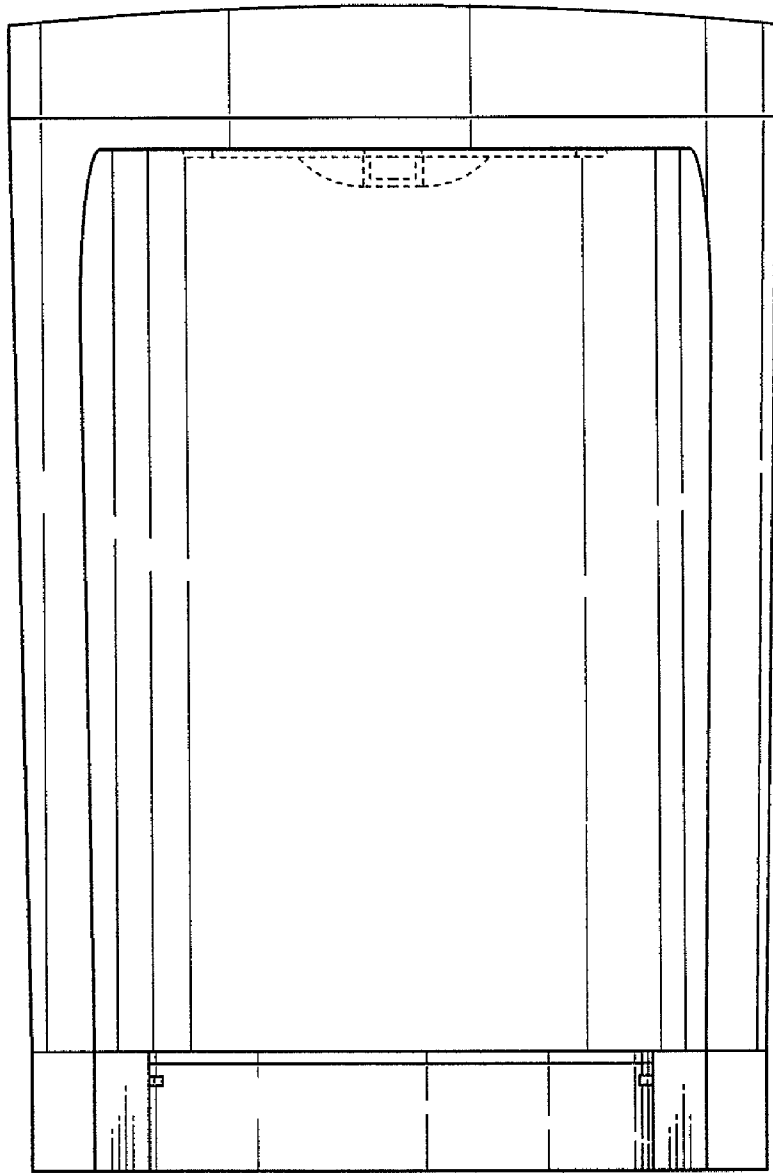

FIG.17

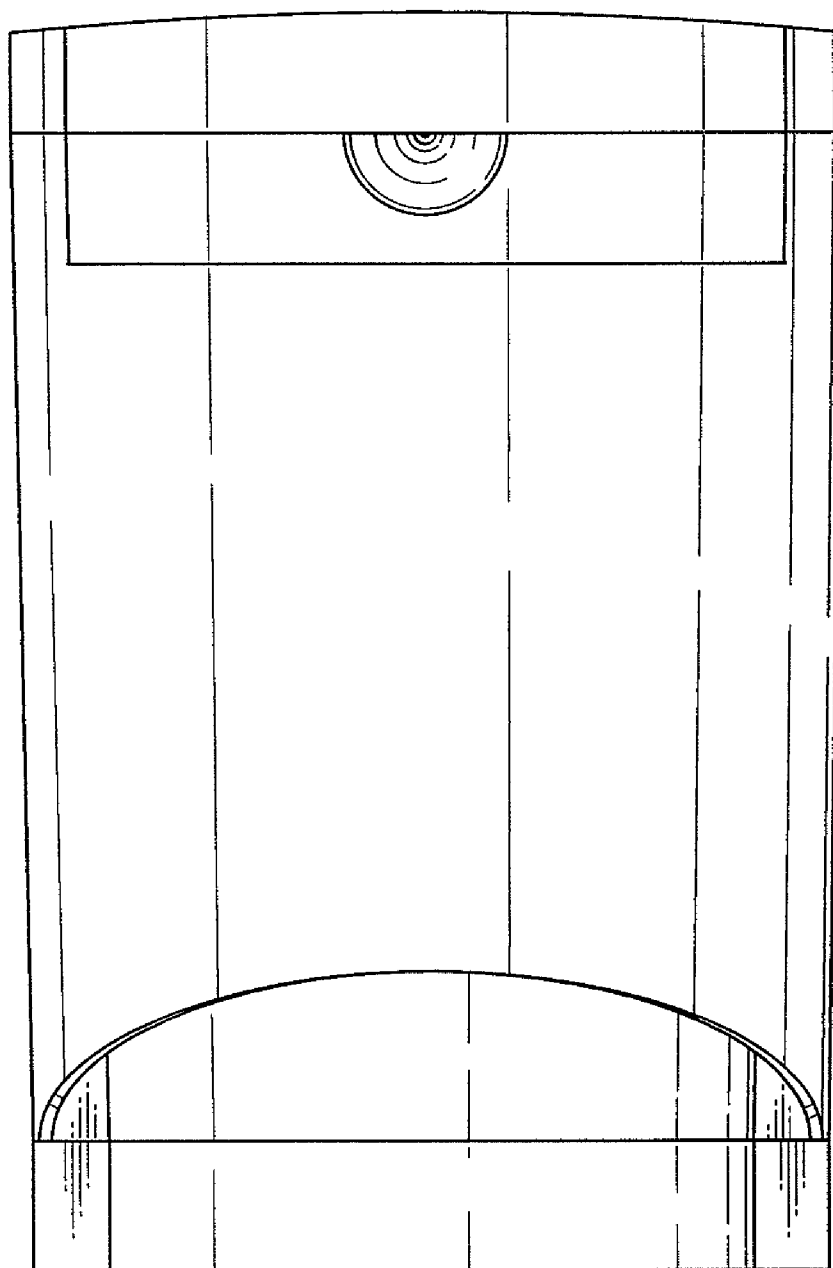

FIG.18

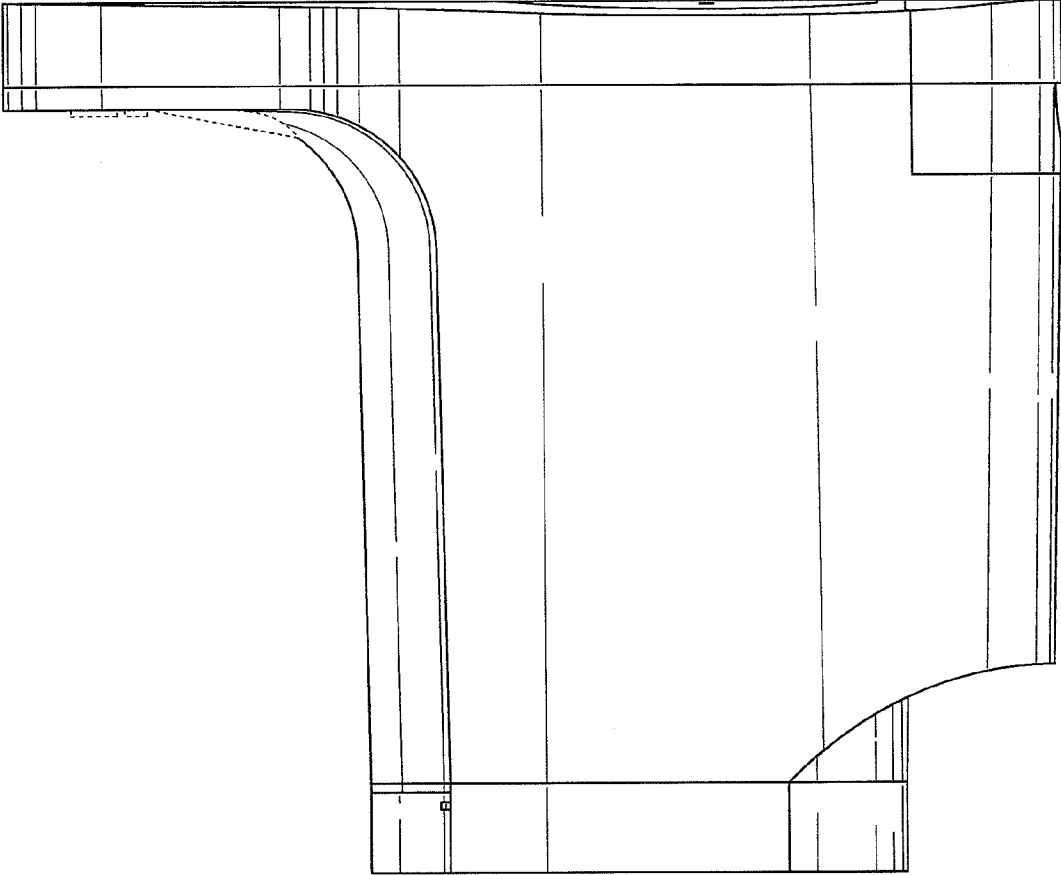

FIG.19

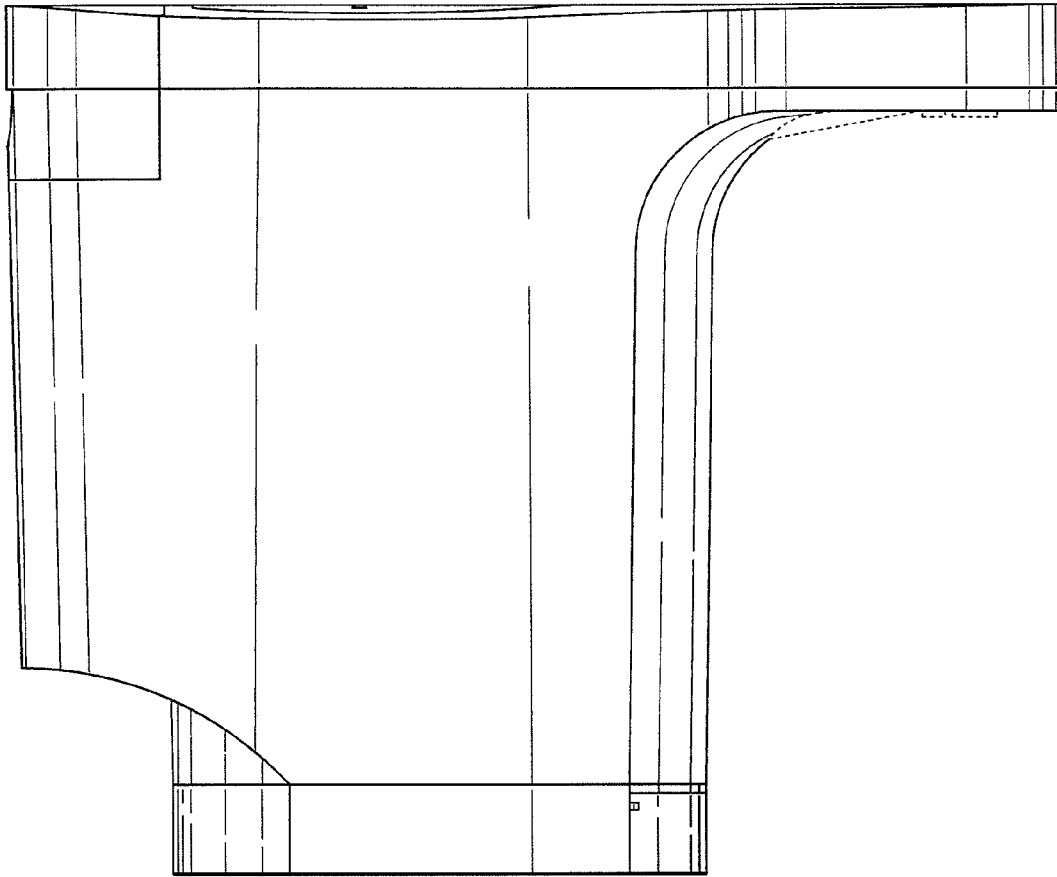

FIG.20

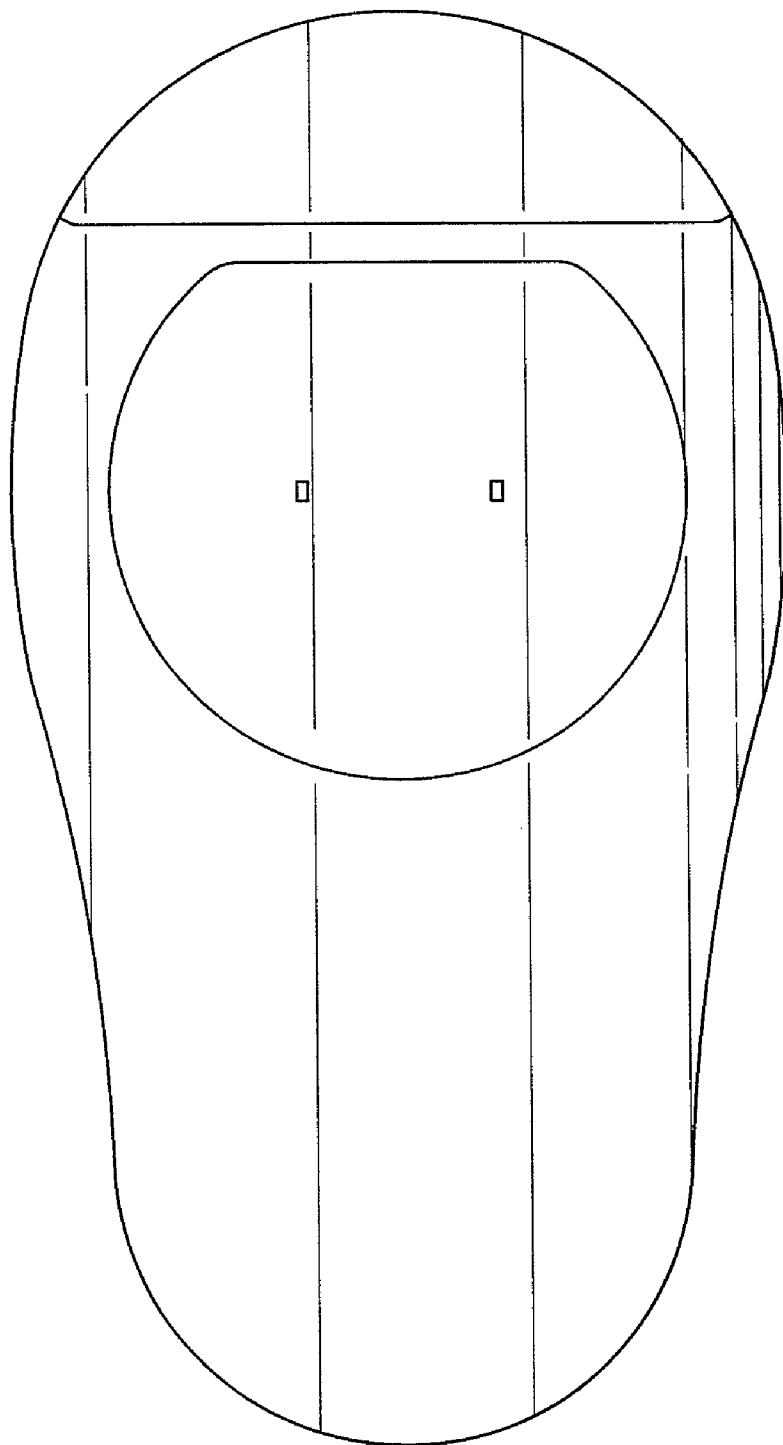

FIG.21

