



US00D337417S

United States Patent [19]

[11] Patent Number: **Des. 337,417**

McNiven

[45] Date of Patent: **** Jul. 13, 1993**

[54] **COMBINED MAILBOX AND STAND**

4,473,182 9/1984 Dion 232/35

[76] Inventor: **Anne K. McNiven**, 19189 Indian Summer Rd., Bend, Oreg. 97702

4,509,675 4/1985 Siff 232/17

4,905,892 3/1990 Fischer 232/17

[**] Term: **14 Years**

Primary Examiner—Alan P. Douglas
Assistant Examiner—J. H. Musgrove
Attorney, Agent, or Firm—Terry M. Gernstein

[21] Appl. No.: **601,572**

[57] **CLAIM**

[22] Filed: **Oct. 23, 1990**

The ornamental design for a combined mailbox and stand, as shown and described.

[52] U.S. Cl. **D99/32**

[58] Field of Search D99/30, 31, 32, 33;
232/7, 17, 34

DESCRIPTION

[56] **References Cited**

FIG. 1 is a front, top and right side perspective view of a combined mailbox and stand showing my new design; FIG. 2 is a right side elevational view thereof; FIG. 3 is a front elevational view thereof; FIG. 4 is a rear elevational view thereof; FIG. 5 is a left side elevational view thereof; and, FIG. 6 is a top view thereof.

U.S. PATENT DOCUMENTS

D. 188,749	9/1960	McAver	D99/32
D. 194,895	3/1963	Bardos	D99/32
D. 322,877	12/1991	Roach	D99/32
4,395,012	7/1983	Rance	246/545

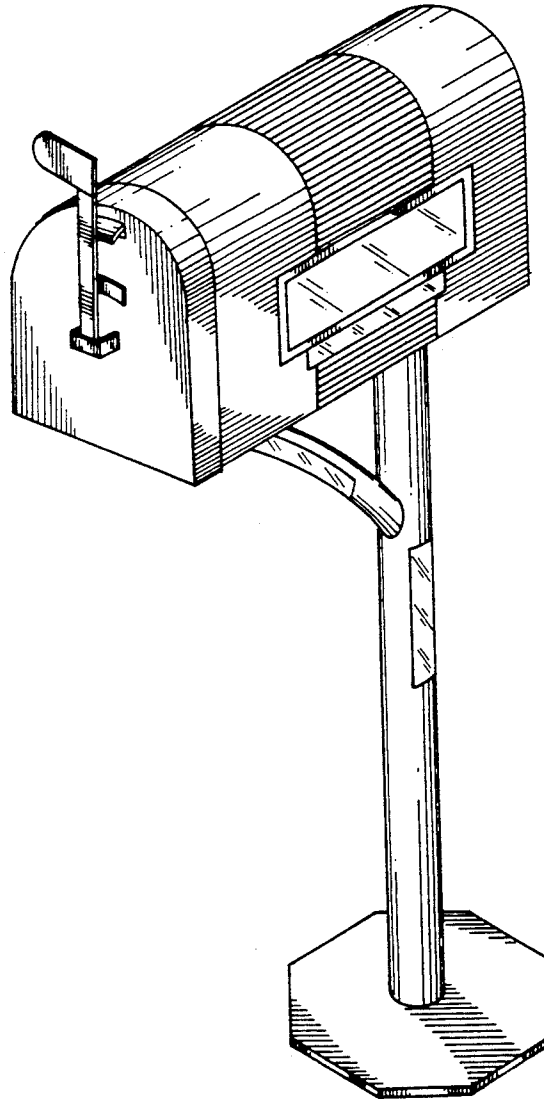

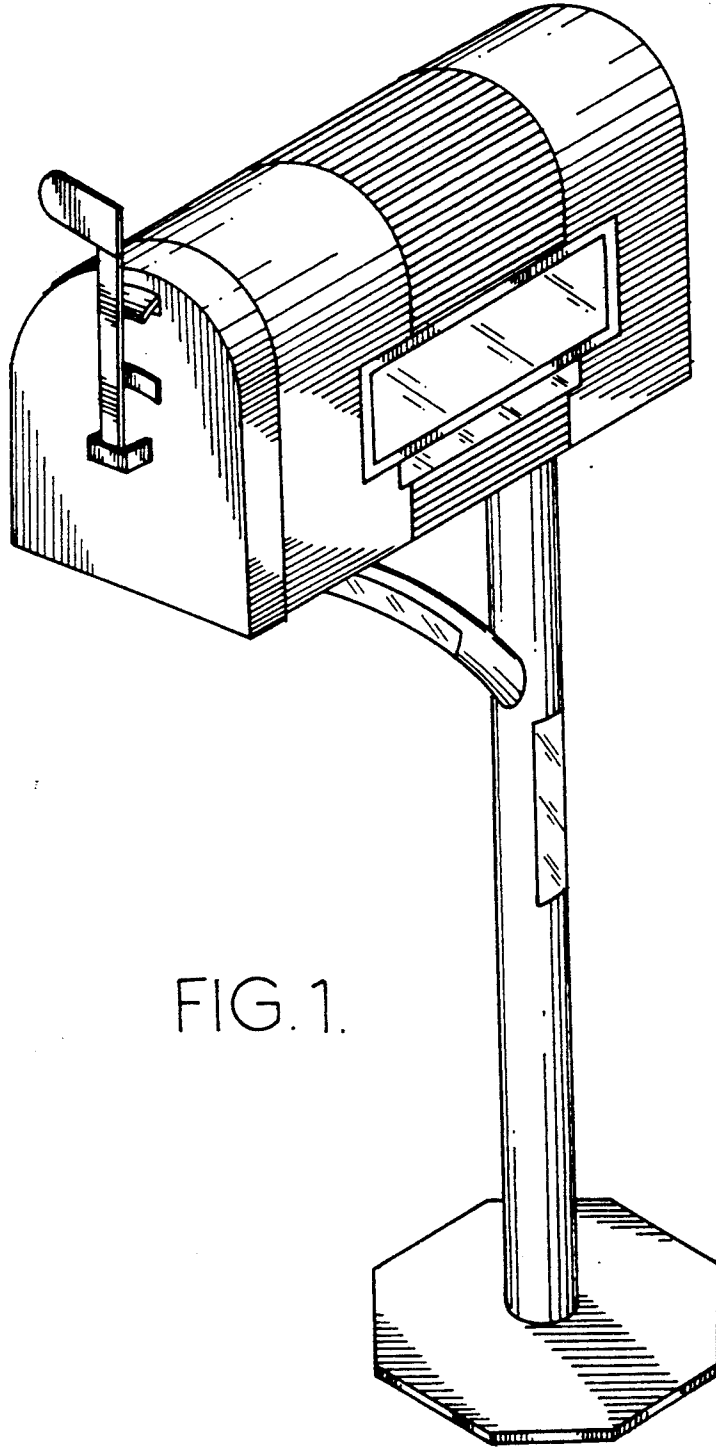

FIG. 1.

FIG. 3.

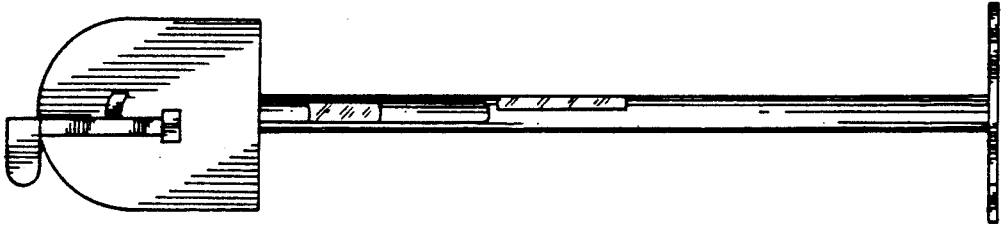

FIG. 2.

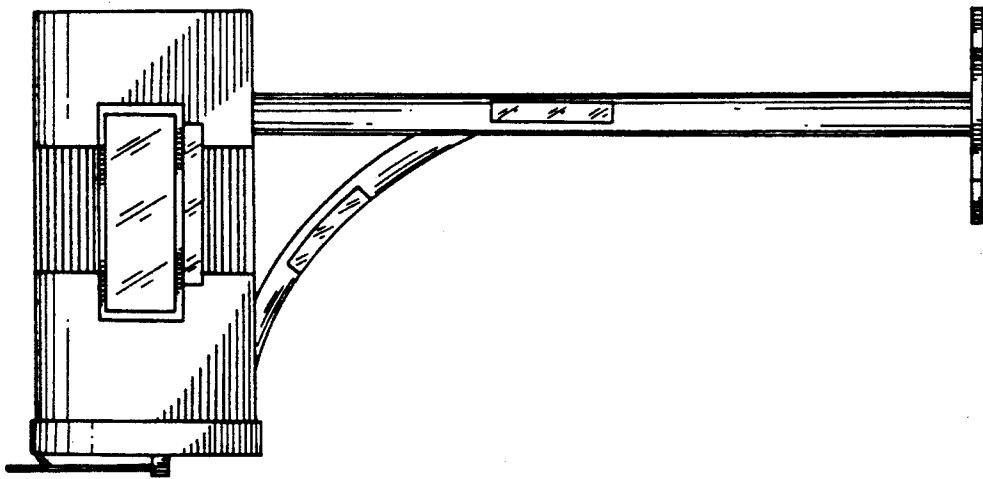

FIG. 4.

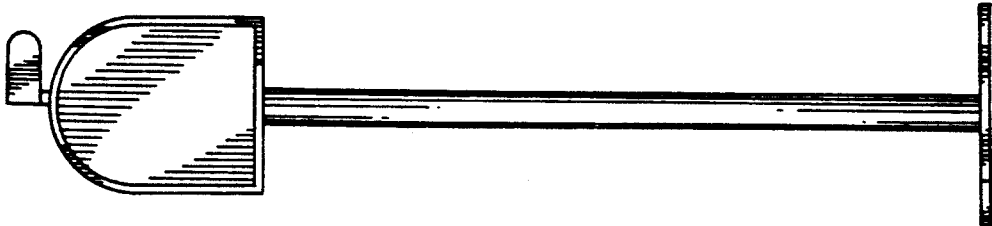

FIG. 5.

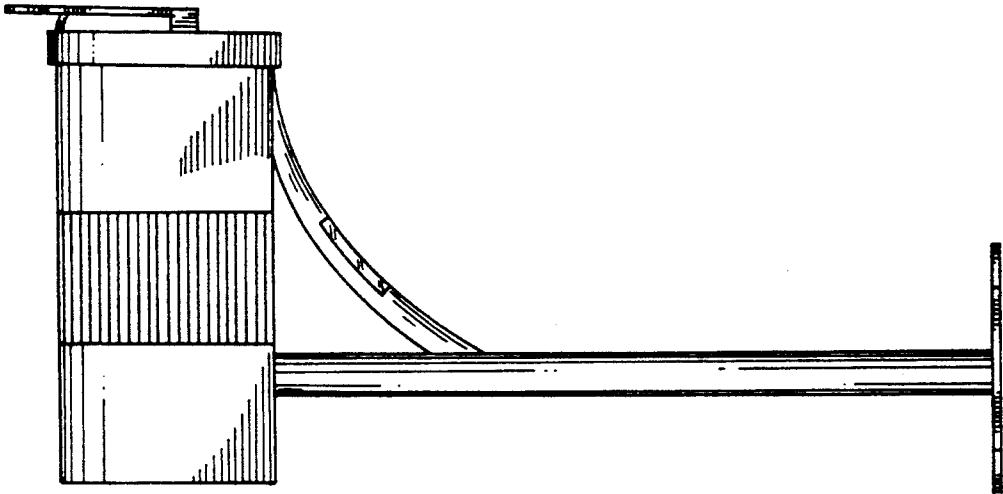

FIG. 6.

