



(19) **United States**

(12) **Patent Application Publication**
Brugger et al.

(10) **Pub. No.: US 2003/0010717 A1**

(43) **Pub. Date: Jan. 16, 2003**

(54) **SYSTEMS AND METHODS FOR HANDLING AIR AND/OR FLUSHING FLUIDS IN A FLUID CIRCUIT**

(52) **U.S. Cl.** **210/650**; 210/195.1; 210/232; 210/252; 210/257.1; 210/258; 210/436; 210/645; 210/646; 210/800; 210/805

(75) Inventors: **James M. Brugger**, Newburyport, MA (US); **Dennis M. Treu**, Bedford, NH (US)

(57) **ABSTRACT**

Correspondence Address:
PROSKAUER ROSE LLP
PATENT DEPARTMENT
1585 BROADWAY
NEW YORK, NY 10036 (US)

Systems and methods handle air and rinsing fluid during fluid processing. The systems and methods eliminate air from a fluid processing system prior to, during, and after use. The systems and methods provide a connector assembly for establishing fluid flow from a fluid source. The connector assembly has discrete first and second passages that prevent communication between the fluid in first passage and the fluid in the second passage. Prior to system use, the connector assembly may be utilized in a priming function to remove residual air from a fluid circuit prior to use. The connector assembly may also be utilized after use to perform a rinse-back function. The rinse-back function serves to remove residual fluid from the system after use. The connector assembly can comprise two, single lumen connectors or one connector with two lumens.

(73) Assignee: **NX Stage Medical, Inc.**

(21) Appl. No.: **09/905,171**

(22) Filed: **Jul. 13, 2001**

Publication Classification

(51) **Int. Cl.⁷** **B01D 61/00**; B01D 61/20; B01D 61/30; B01D 37/00; B01D 36/00

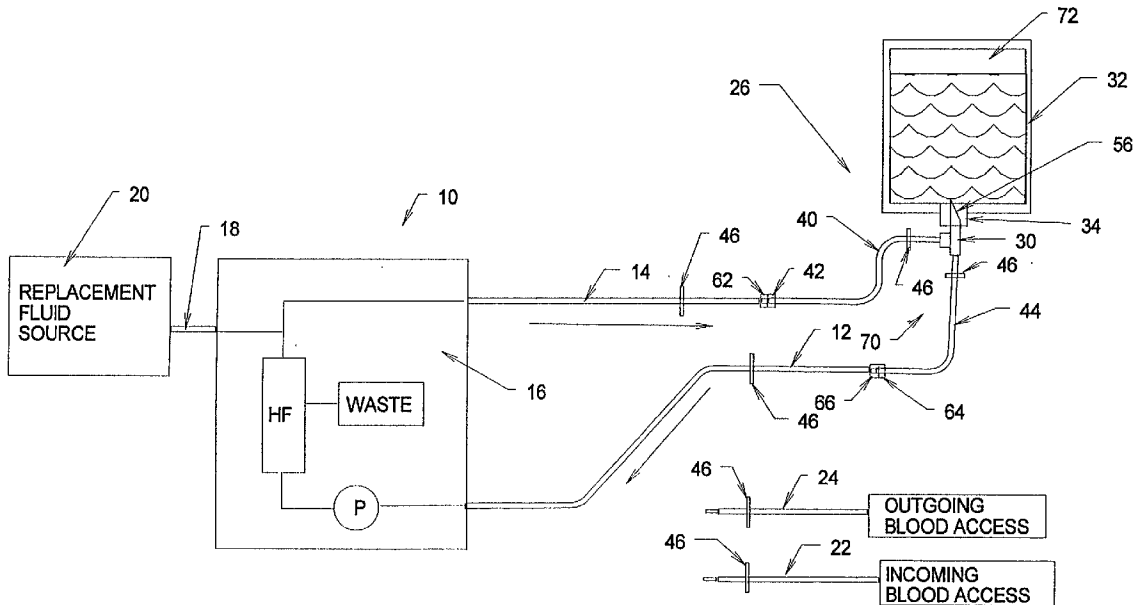

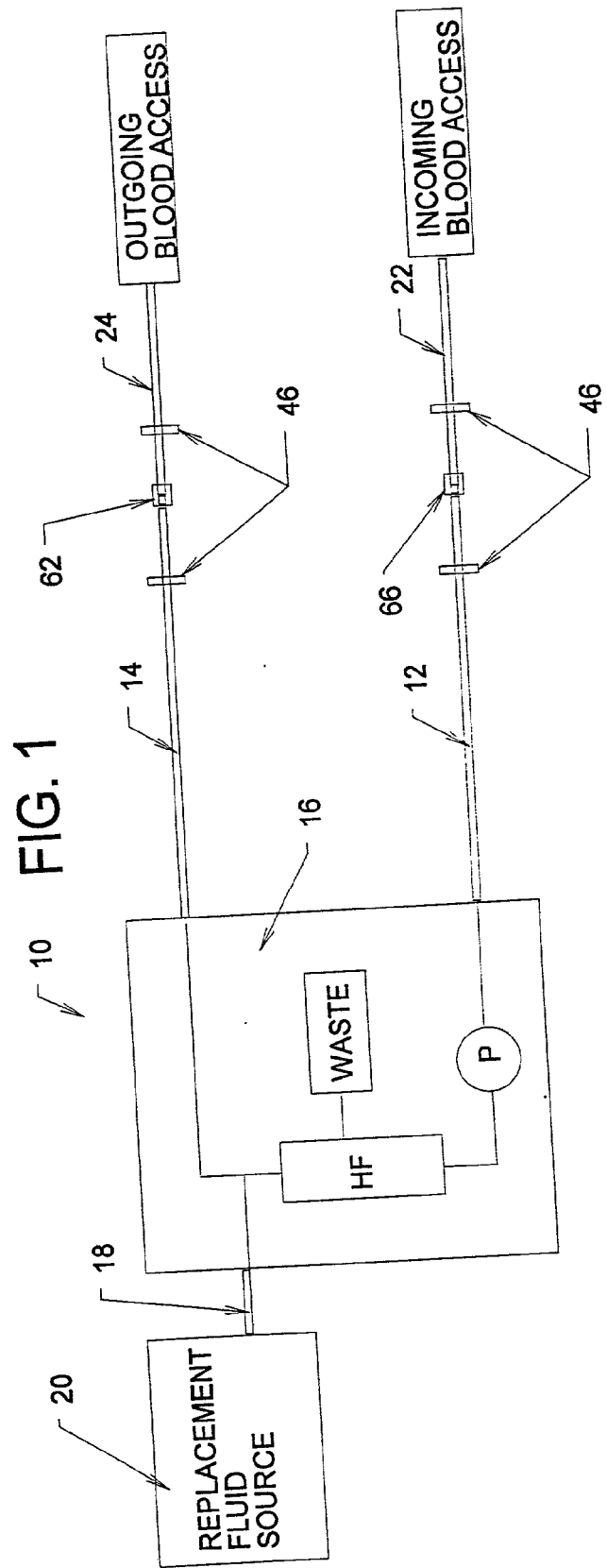

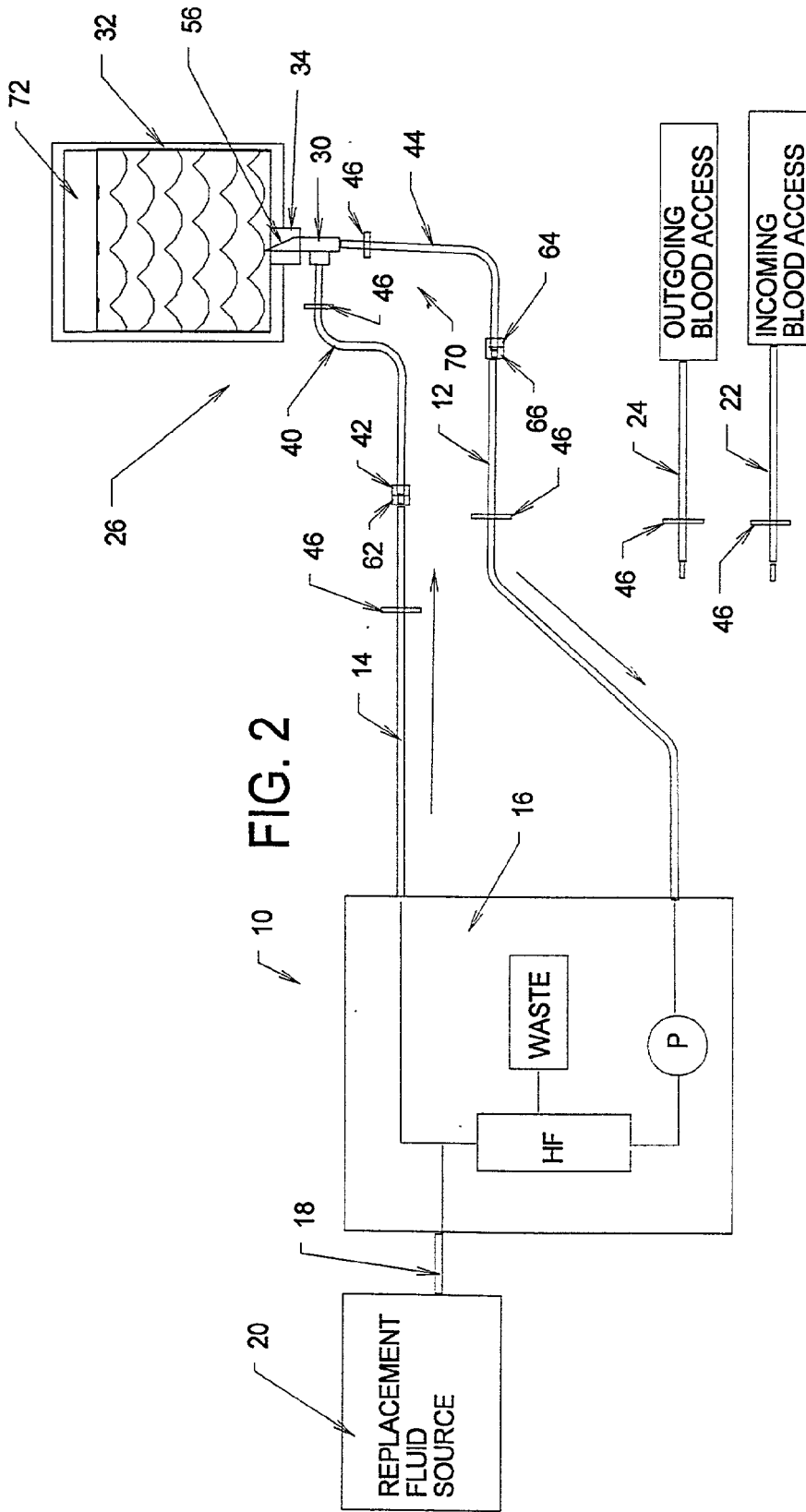

FIG. 2

FIG. 3A

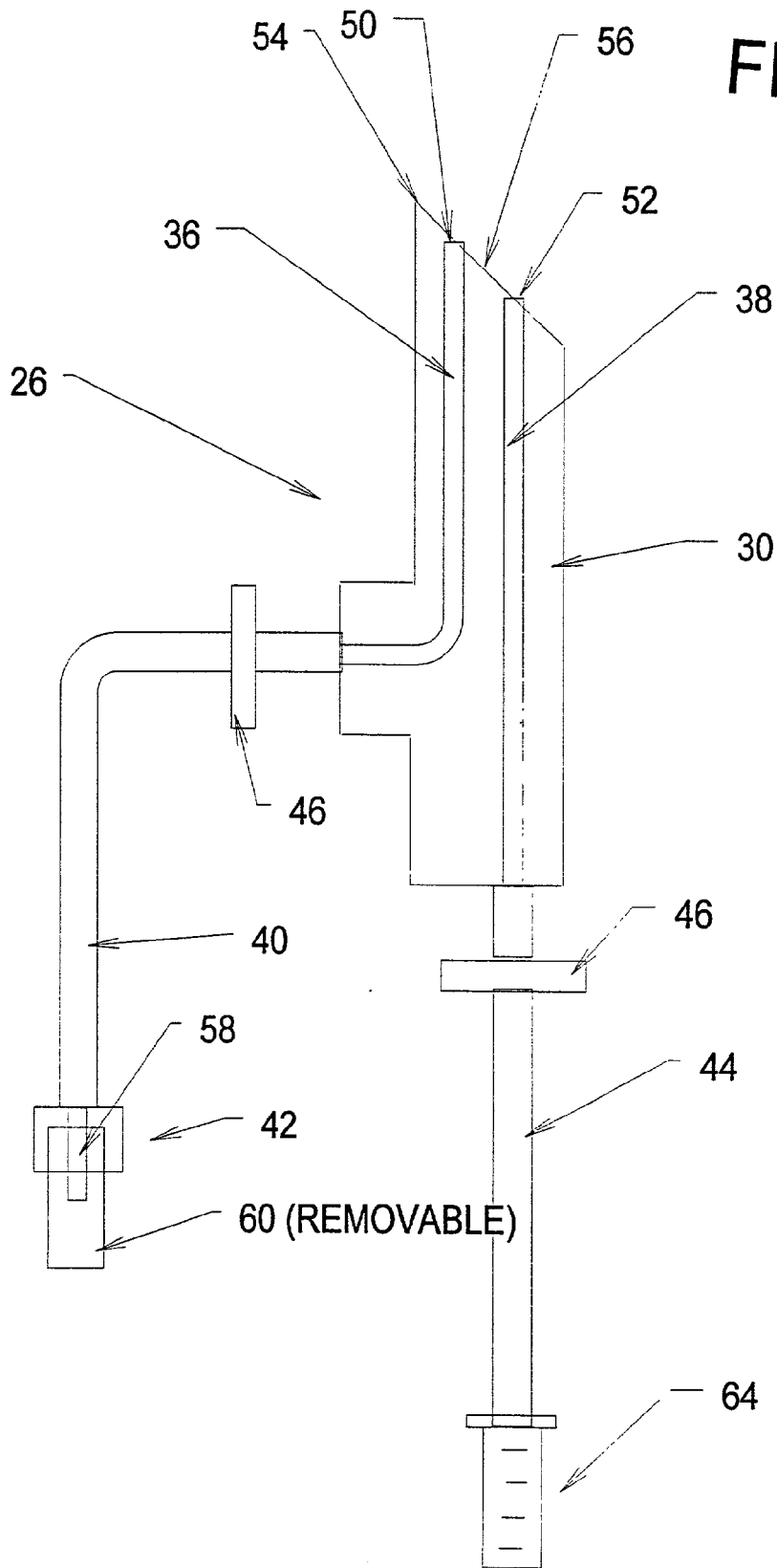
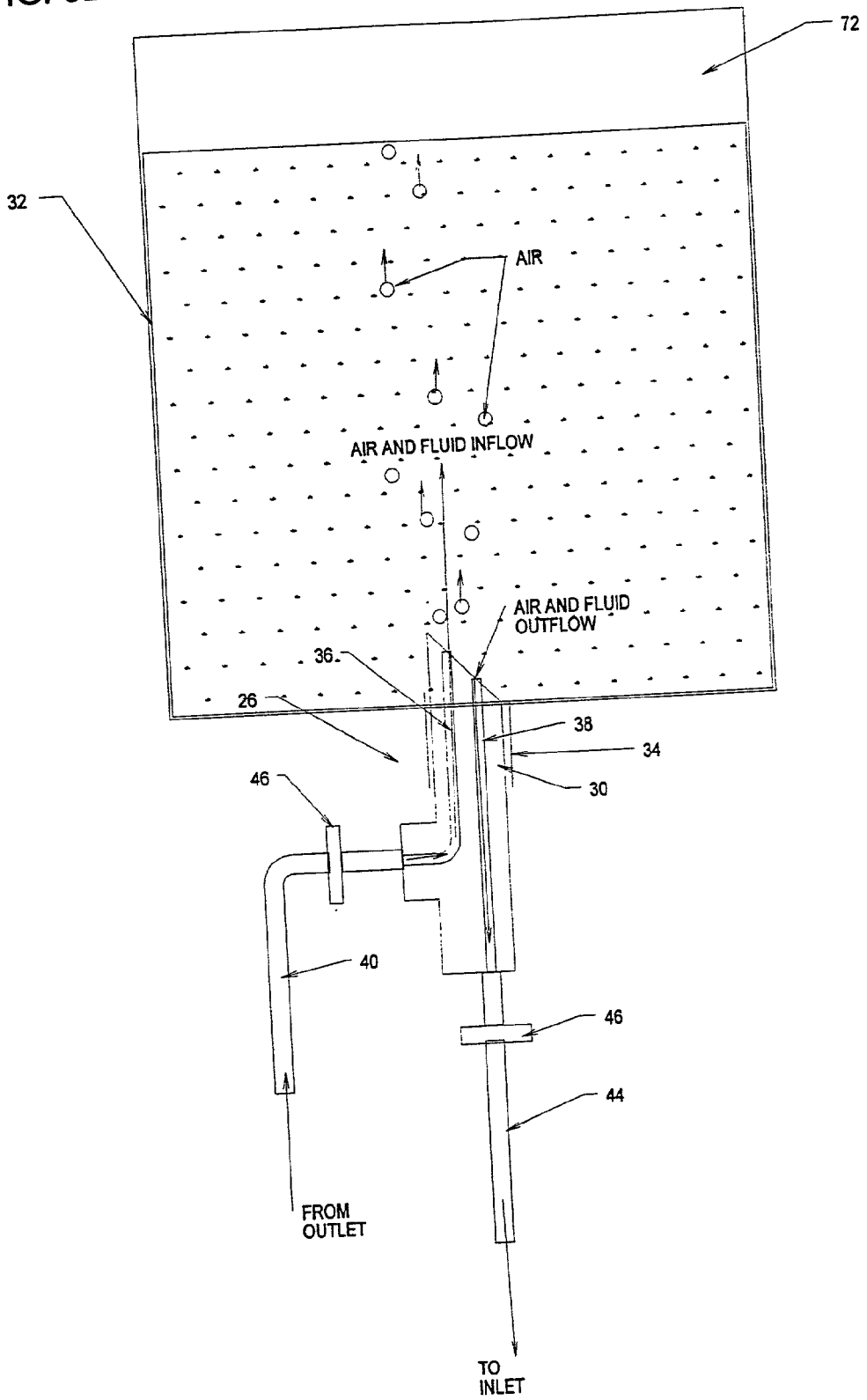

FIG. 3B



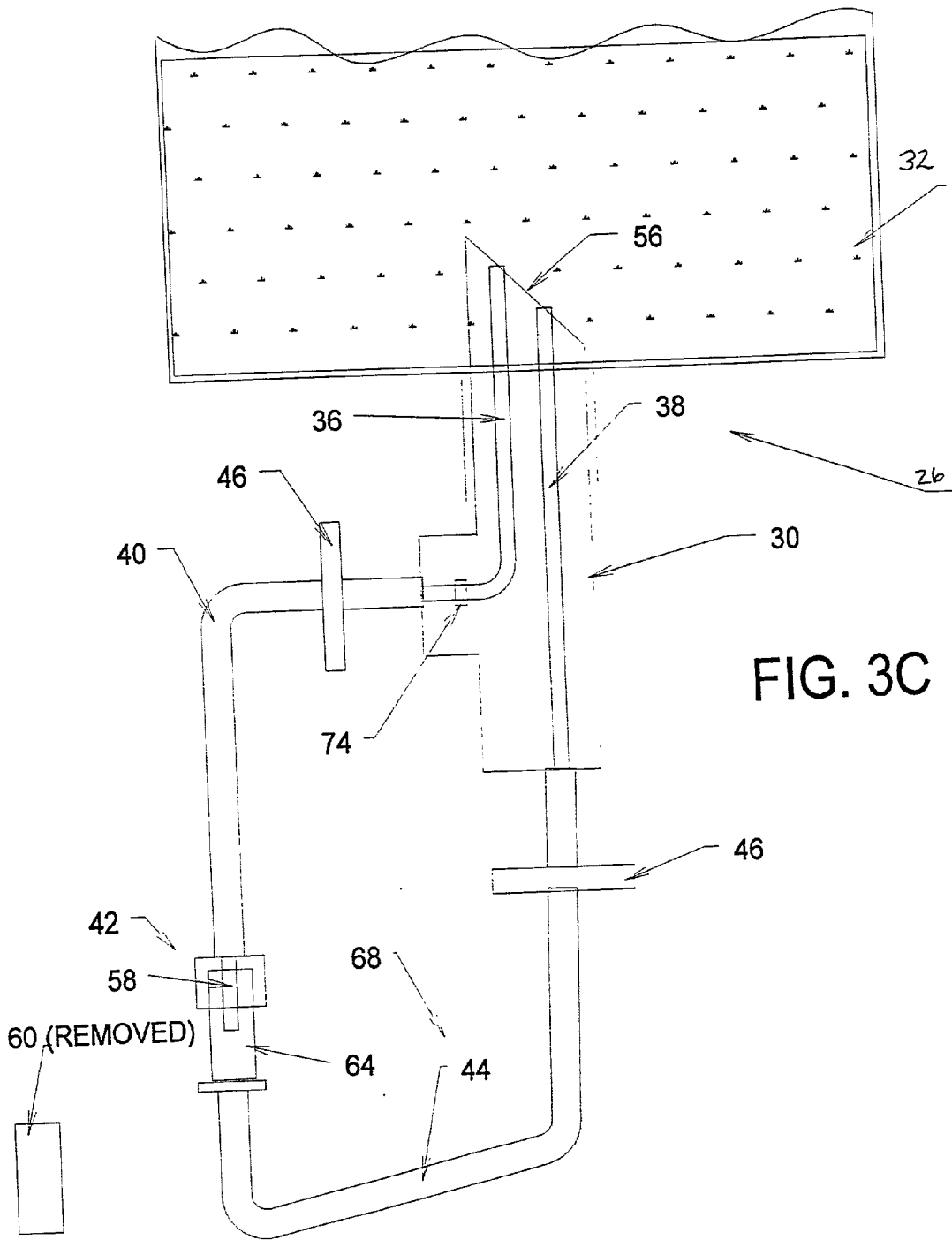

FIG. 3C

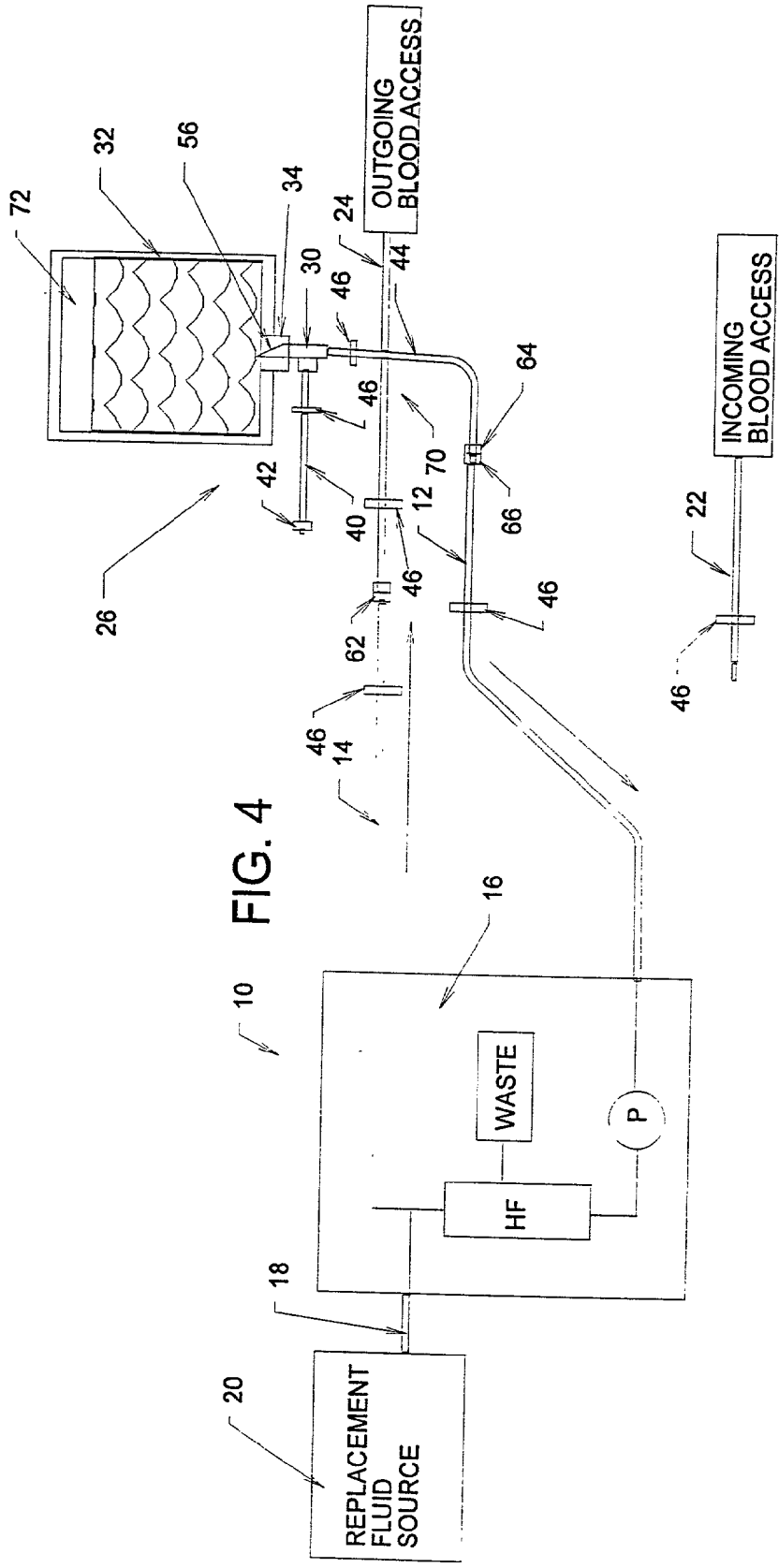

FIG. 4

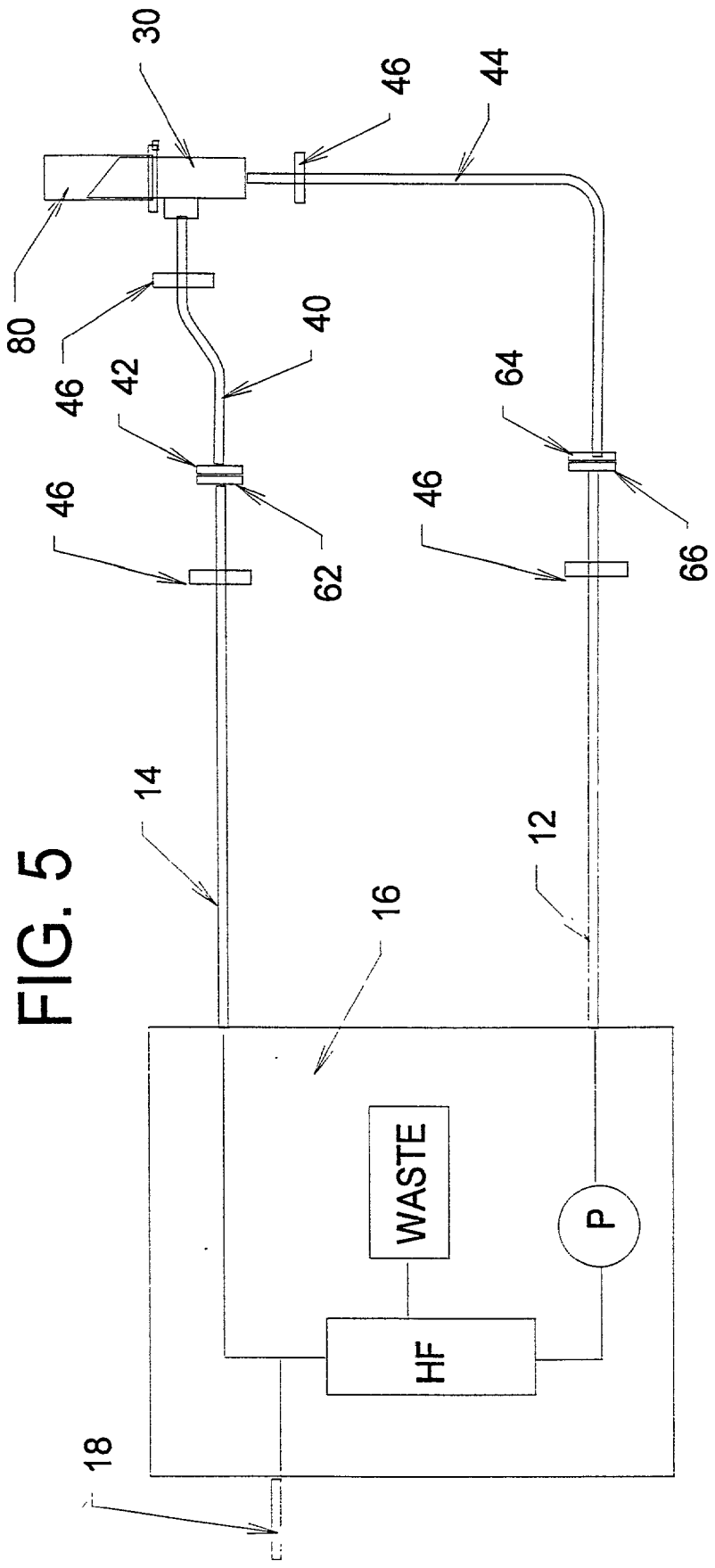
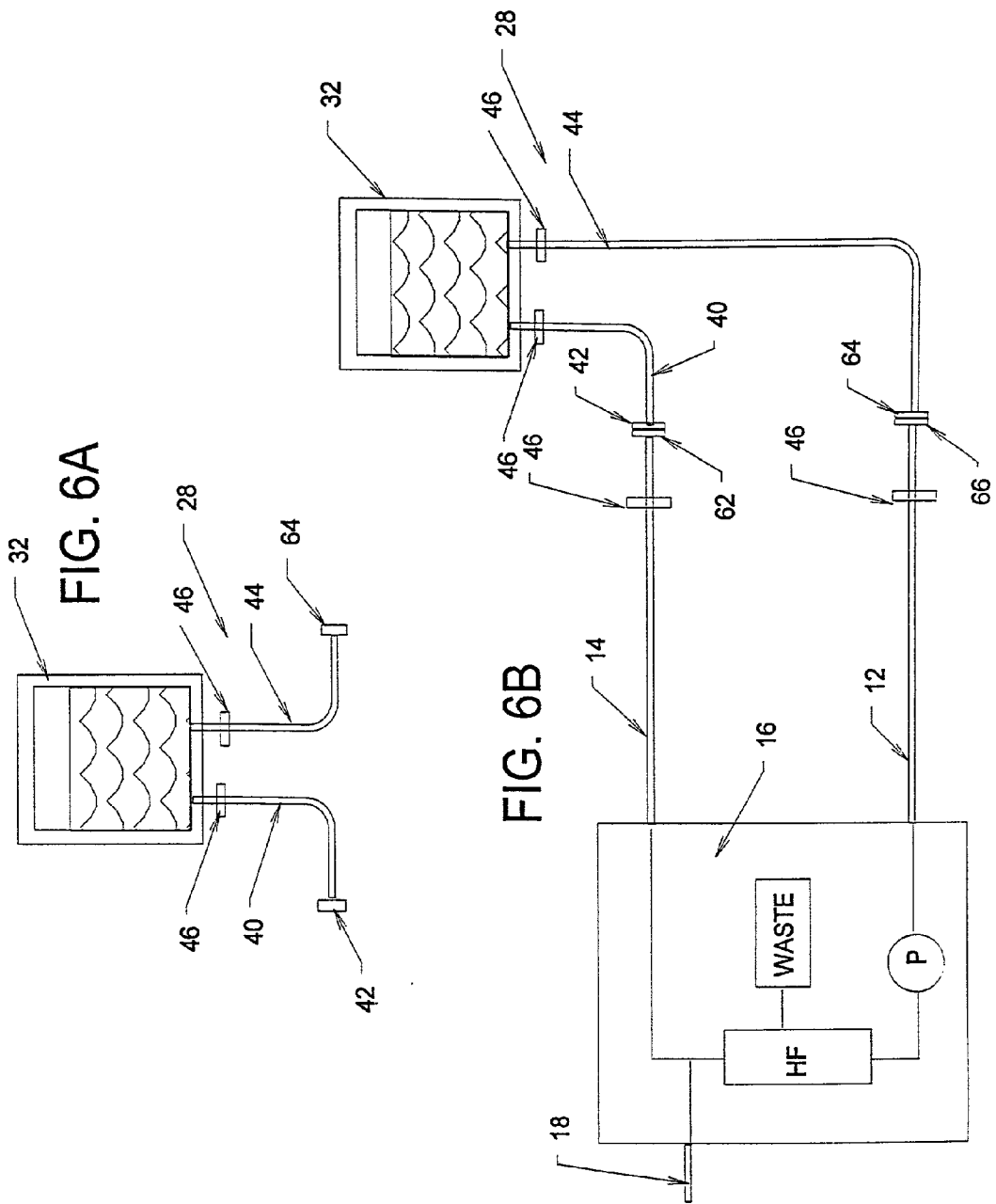

FIG. 5



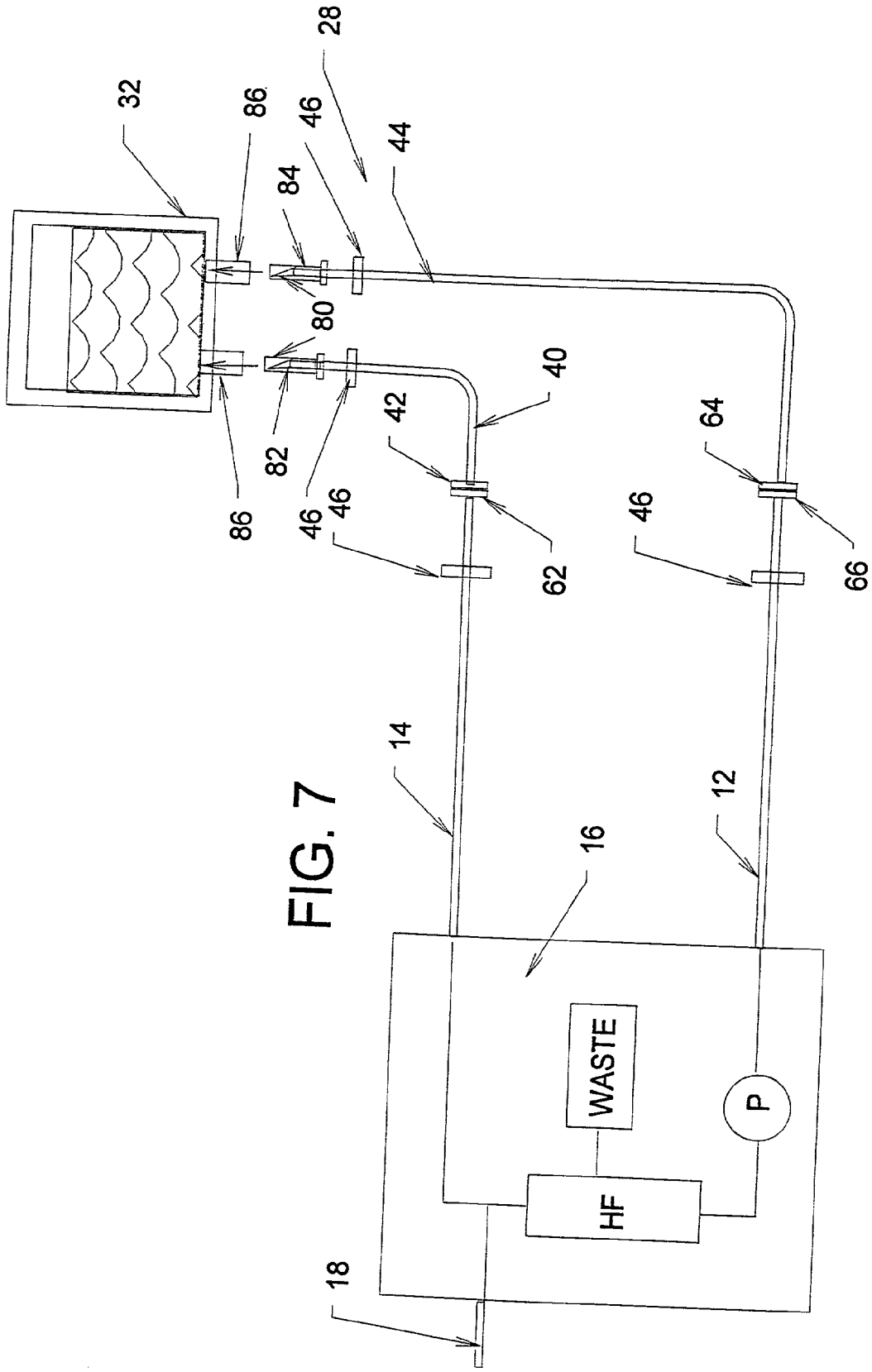
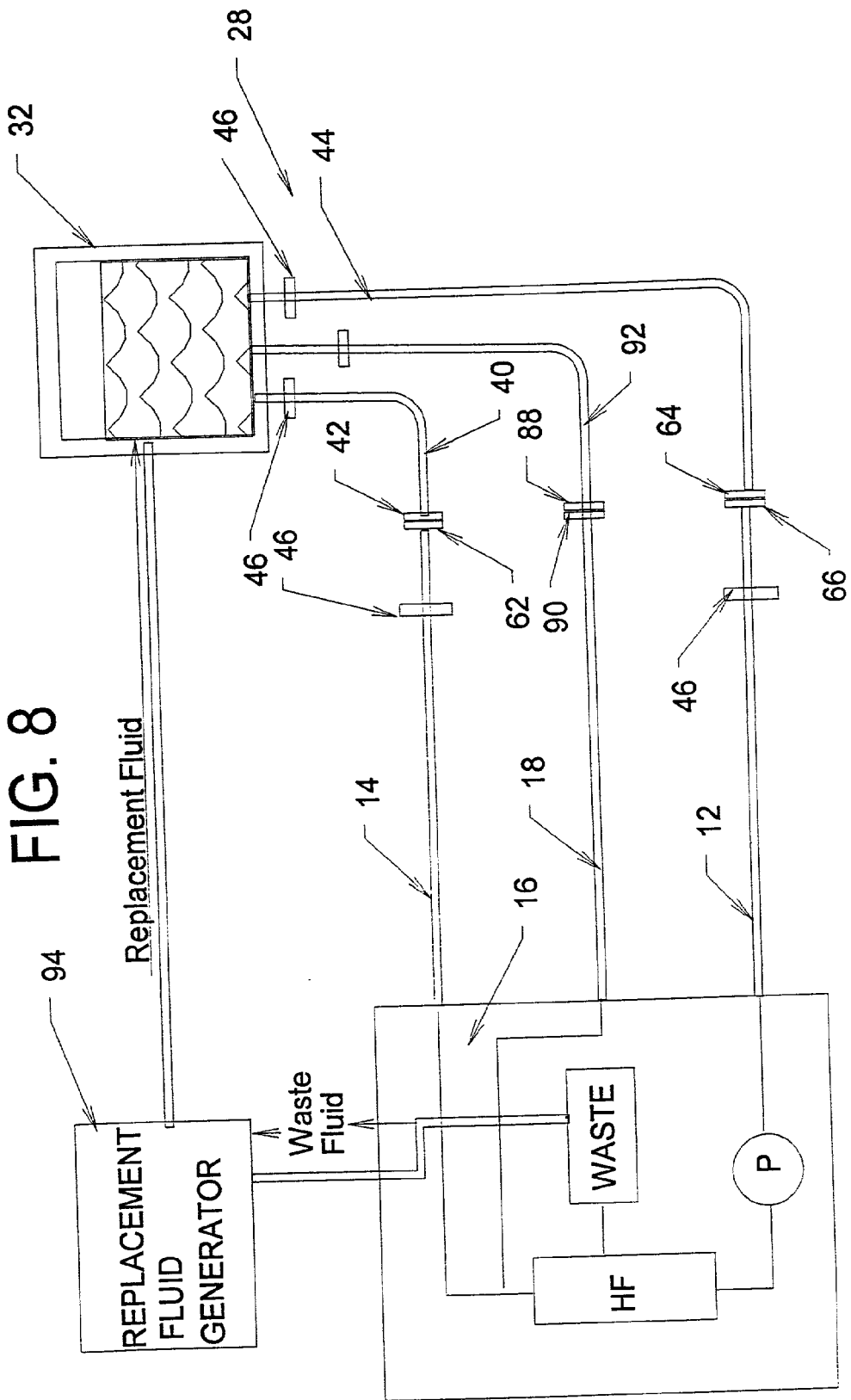

FIG. 7



SYSTEMS AND METHODS FOR HANDLING AIR AND/OR FLUSHING FLUIDS IN A FLUID CIRCUIT

FIELD OF THE INVENTION

[0001] The invention generally relates to fluid processing systems and methods. In particular, the invention relates to systems and methods that process blood or fluids that are introduced into the body, for example, during filtration, dialysis, or other diagnostic or therapeutic purposes.

BACKGROUND OF THE INVENTION

[0002] Systems are well known that process or treat blood or other fluids, and that return processed or treated blood or fluids to an individual. It is necessary to eliminate air from such systems prior to and during use, to avoid introduction of air into the individual undergoing treatment. Typically, drip chambers are used. It is also desirable, after use, to flush residual blood or fluid from the system, typically for return to the individual undergoing treatment.

[0003] There remains a demand for straightforward ways to handle air and to rinse residual blood or fluids from blood or fluid processing systems.

SUMMARY OF THE INVENTION

[0004] The invention provides systems and methods for handling air in a fluid processing circuit. The invention also provides systems and methods for rinsing or flushing residual fluids from a fluid processing circuit after processing is concluded.

[0005] One aspect of the invention provides systems and methods for priming a fluid circuit. The systems and methods couple a connector assembly to a fluid reservoir. The connector assembly comprises a first fluid passage and a second fluid passage. The systems and methods circulate fluid in the fluid circuit through the fluid reservoir, by conveying fluid into the inlet of the fluid circuit from the reservoir through the second fluid passage while conveying fluid from the outlet of the fluid circuit into the reservoir through the first fluid passage. During the circulation step, the systems and methods accumulate air residing in the fluid circuit in the fluid reservoir, thereby removing air from the fluid circuit.

[0006] In one embodiment, the systems and methods releasably couple the first fluid passage to the outlet of the fluid circuit, and also releasably couple the second fluid passage to the inlet of the fluid circuit. In one arrangement, the systems and methods couple the first and second passages together in a loop after the accumulating step.

[0007] In one embodiment, the systems and methods convey fluid into the fluid reservoir at a higher gravity height than fluid is conveyed from the fluid reservoir.

[0008] Another aspect of the invention provides systems and methods for both priming and flushing a fluid circuit. The systems and methods provide a connector assembly comprising a first fluid passage that is releasably coupled to an outlet of the fluid circuit and a second fluid passage that is releasably coupled to an inlet of the fluid circuit. The systems and methods couple the connector assembly to a fluid reservoir. The systems and methods prime the fluid circuit through the fluid reservoir by conveying fluid into the

inlet of the fluid circuit from the reservoir through the second fluid passage while conveying fluid from the outlet of the fluid circuit into the reservoir through the first fluid passage. After the priming step, the systems and methods release the coupling between the connector assembly and the inlet and outlet of the fluid circuit, while keeping the connector assembly coupled to the fluid reservoir. The systems and methods then process a selected fluid using the fluid circuit. After the processing step, the systems and methods couple the inlet of the fluid circuit to the second fluid passage. The systems and methods then rinse residue of the selected fluid from the fluid circuit by conveying fluid into the inlet of the fluid circuit from the reservoir through the second fluid passage, while conveying the selected fluid residue from the outlet of the fluid circuit in a path that bypasses the reservoir.

[0009] In one embodiment, during the processing step, the first and second fluid passages are coupled together in a loop.

[0010] Another aspect of the invention provides a fluid processing apparatus comprising a fluid container, and a connector assembly coupled to the fluid container. The connector assembly includes a first fluid passage that is releasably coupled by a luer connector to an outlet of a fluid circuit. The connector assembly also includes a second fluid passage that does not communicate with the first fluid passage and that is releasably coupled by a luer connector to an inlet of the fluid circuit. In this arrangement, fluid can be circulated by the connector assembly through the fluid container in a loop that includes the fluid circuit to collect in the fluid source air residing in the fluid circuit.

[0011] Regarding any above-discussed aspect of the invention, the connector assembly can, in one embodiment, comprise a single connector body that includes both the first and second fluid passages. In one arrangement, the connector body includes a distal end having a taper to form a spike, which can be coupled to the fluid reservoir, e.g., by penetrating a port tube membrane.

[0012] Regarding any above-discussed aspect of the invention, the connector assembly can comprise, in another embodiment, a first connector body that includes the first fluid passage and a second connector body that includes the second fluid passage. In one arrangement, each of the first and second connector bodies includes a distal end having a taper to form a spike, which can be coupled to the fluid reservoir, e.g., by penetrating a port tube membrane.

[0013] Another aspect of the invention provides a dual lumen connector for coupling to a fluid source. The connector comprises a body in which there are first and second fluid passages that do not communicate with each other. A first assembly communicates with the first fluid passage and includes a first fitting to releasably couple the first fluid passage to an outlet of a fluid circuit. A second assembly communicates with the second fluid passage and includes a second fitting to releasably couple the second fluid passage to an inlet of the fluid circuit. Using the connector, fluid can be circulated through the fluid source in a loop that includes the fluid circuit to collect in the fluid source air residing in the fluid circuit.

[0014] The fluid circuit used in association with the invention in all of its various aspects can itself take various forms

and functions. The fluid circuit can, for example, comprise at least a portion of a hemofiltration system, or a hemodialysis system, or a hemodiafiltration system, or a peritoneal dialysis system.

[0015] The invention makes possible the use of fluid circuits free of drip chambers, thereby minimizing the quantity of priming fluid discarded during priming.

[0016] Other features and advantages of the inventions are set forth in the following specification and attached drawings.

BRIEF DESCRIPTION OF THE DRAWINGS

[0017] FIG. 1 is a schematic view of a generic fluid processing system;

[0018] FIG. 2 is a schematic view of a priming system that can be used with the fluid processing system shown in FIG. 1, which includes a dual lumen connector assembly;

[0019] FIG. 3A is an enlarged side sectional view of the dual lumen connector assembly that forms a part of the priming system shown in FIG. 2;

[0020] FIG. 3B is an enlarged side sectional view of the dual lumen connector assembly shown in FIG. 3A when performing a priming function;

[0021] FIG. 3C is an enlarged side sectional view of the dual lumen connector assembly shown in FIG. 3A formed into a closed loop that preserves its sterility after performing the priming function shown in FIG. 3B and before performing a rinse-back function;

[0022] FIG. 4 is a schematic view of a rinse-back system that can be used with the fluid processing system shown in FIG. 1, and which includes the same dual lumen connector assembly that previously performed the priming function shown in FIG. 3B;

[0023] FIG. 5 is a schematic view of a system with a dual lumen connector assembly as shown in FIG. 3A, which is supplied to an operator preconnected to a fluid circuit;

[0024] FIG. 6A is a schematic view of an alternative fluid priming assembly comprising a priming container with integrally connected first and second tubing assemblies that can be used with the fluid processing system shown in FIG. 1;

[0025] FIG. 6B is a schematic view of a system formed after connecting the fluid priming assembly shown in FIG. 6A with the fluid circuit shown in FIG. 1;

[0026] FIG. 7 is a schematic view of an alternative embodiment of a fluid priming assembly, which is supplied to an operator preconnected to a fluid circuit; and

[0027] FIG. 8 is a schematic view of a container that carries replacement fluid and that includes both an associated fluid priming assembly and replacement fluid inlet path.

[0028] The invention may be embodied in several forms without departing from its spirit or essential characteristics. The scope of the invention is defined in the appended claims, rather than in the specific description preceding them. All embodiments that fall within the meaning and range of equivalency of the claims are therefore intended to be embraced by the claims.

DESCRIPTION OF THE PREFERRED EMBODIMENT

[0029] I. System Overview

[0030] FIG. 1 schematically shows the components of a generic fluid processing system 10. The system 10 has a first inlet 12 for receiving fluid and an outlet 14 for discharging fluid. A fluid circuit 16 is coupled between the first inlet 12 and the outlet 14, through which the incoming fluid flows and is then discharged. The fluid circuit 16 processes the fluid in a desired manner and can be conventional.

[0031] The fluid circuit 16 may also include a second inlet 18 through which a processing fluid is introduced into the fluid circuit 16. The processing fluid is drawn from a source 20, which can be fluid containers or a sterile fluid generating source. The sterile fluid can be generated, e.g., by treating water from an external source, or by sterile filtering a fluid waste product of the fluid circuit 16 itself, e.g., as disclosed in application Ser. No. 09/027,301 filed Feb. 19, 1998 and entitled "Hemofiltration System Including Ultrafiltrate Purification and Reinfusion System," which is incorporated herein by reference.

[0032] The fluid processing system 10 can take various forms. It can, for example, comprise a blood processing system for conducting hemofiltration, or hemodialysis, or hemodiafiltration. The system 10 can also comprise a peritoneal dialysis system.

[0033] As will be described herein for purpose of illustration, the system 10 forms a part of a hemofiltration system. The system receives through the first inlet 12 blood from an individual, e.g., through a suitable incoming blood line 22, which can comprise an access site for withdrawing blood from an individual, e.g., by connection to an artery, a vein, or a fistula. An in-line pinch clamp 46 or the like can be provided in the blood line 22. A pumping mechanism P in the fluid circuit 16 pumps the blood through a hemofilter HF, where toxins (WASTE) are removed. The treated blood is discharged through the outlet 14 for return to the circulatory system of the individual, e.g., through a suitable outgoing blood line 24, which can comprise an access site for returning blood to an individual, e.g., typically by connection to a vein. An in-line pinch clamp 46 or the like can also be provided in the blood line 24.

[0034] During hemofiltration, a replacement fluid is typically added to the treated blood through the second inlet 18, to make up for the fluid lost during toxin removal. Typically, the replacement fluid is added in volumetric proportion to the amount of fluid removed from the blood. The replacement fluid is drawn from the source 20, which communicates with to the second inlet 18.

[0035] As is the case before using many fluid processing systems, it is necessary before conducting hemofiltration to remove residual air from the fluid circuit 16 and, after conducting hemofiltration, to rinse blood and residual fluid from the fluid circuit 16.

[0036] Accordingly, the system 10 includes a fluid priming assembly 26 (shown in FIGS. 2; 3A/B/C; and 4). The purposes of the fluid priming assembly 26 are (1) to prime the system and thereby remove residual air from the fluid circuit 16 prior to use, and (2) to "rinse back" or flush residual blood from the fluid circuit 16 after use.

[0037] Further details of the fluid priming assembly 26 will now be described.

[0038] II. The Fluid Priming Assembly

[0039] A. Priming Function

[0040] Details of the fluid priming assembly 26 are illustrated in FIGS. 2; 3A/B/C; and 4).

[0041] As there shown, the fluid priming assembly 26 includes a connector 30 formed, e.g., from hard, medical grade plastic. There are two fluid passages (lumens) 36 and 38 (see FIG. 3A) formed in the body of the connector 30. These passages 36 and 38 can be formed, e.g., by conventional molding techniques. These passages 36 and 38 are discrete, such that the second fluid passage 38 does not communicate with the first fluid passage 36 within the body of the connector 30.

[0042] In use, the connector 30 is intended to be coupled in fluid communication with a container 32 of priming solution. The priming container 32 can comprise, e.g., flexible bag containing saline or other suitable priming solution. In use, the priming container 32 is positioned above the fluid circuit 16. Alternatively, the processing fluid source 20 can also be used as the source of priming solution.

[0043] The connector 30 may be coupled to the priming container 32 in various conventional ways, e.g., through a luer fitting or by penetration of a port tube membrane 34. In the illustrated embodiment (see FIG. 3B), the priming container 32 includes a port tube membrane 34. In this arrangement, the tip end of the connector 30 is tapered to form a spike 56, providing a configuration similar to vented-type spikes for rigid bottles. In the illustrated embodiment (see FIG. 3A), the opening 50 of the first fluid passage 36 into the container 32 is located closer to the high tapered end 54 of the spike 56 than the opening 52 of the second fluid passage 38 into the container 32. Thus, the first fluid passage 36 enters the container 32 at a higher gravity position than the second fluid passage 38. The benefits of this configuration will be discussed later.

[0044] The fluid priming assembly 26 includes a first flexible tubing assembly 40 (see FIG. 3A) coupled to the connector 30. The first tubing assembly 40 communicates only with the first fluid passage 36. The first tubing assembly 40 terminates with a connector 42 to releasably connect the first fluid passage 36 to the fluid circuit 16. The connector 42 can take various forms, depending upon the configuration of the mating connector in the fluid circuit 16. In the illustrated embodiment, the connector 42 comprises a male luer 58 with a removable female-to-female connector 60 carried by the male luer 58. The removable connector 60 carried by the male luer 58 is adapted to be coupled to a mating male connector 62 on the outlet 14 of the the fluid circuit (as FIG. 2 shows). In use (see FIG. 3B), priming fluid and residual air in the fluid circuit 16 is pumped by way of the first tubing assembly 40, into the first fluid passage 36 and into the priming container 32.

[0045] The fluid priming assembly 26 includes a second flexible tubing assembly 44 (see FIG. 3A) coupled to the connector 30. The second tubing assembly 44 communicates only with the second fluid passage 38. The second tubing assembly 44 terminates with a connector 64 to releasably connect the second fluid passage 36 to the fluid circuit 16.

The connector 64 can take various forms, depending upon the configuration of the mating connector in the fluid circuit 16. In the illustrated embodiment, the connector 64 comprises a female luer connector that is adapted to be coupled to a mating male connector 66 on the inlet 12 of the fluid circuit (see FIG. 2). In use (see FIG. 3B), vented fluid (free of air) is conveyed by way of the second tubing assembly 44 into the fluid circuit 16, from the priming container 32 into the second fluid passage 38.

[0046] Desirably, the connectors 42 and 64 are configured to also enable their connection one to the other in a sterile fashion (see FIG. 3C). In this way, after disconnection from the fluid circuit 16, the first and second tubing assemblies 40 and 44 can be coupled together to form a closed loop 68, to maintain sterility after being used to perform a priming function, so that additional functions, e.g., a rinse-back function, can be performed using the same connector 30 and priming container 32. Further details of this feature will be described later.

[0047] With the first and second tubing assemblies 40 and 44 coupled to the fluid circuit 16 in the manner shown in FIG. 2, the connector 30 forms a priming loop 70 that circulates the priming solution through both the priming container 32 and the fluid circuit 16. Conventional pinch clamps 46 are provided on both the first tubing assembly 40 and the second tubing assembly 44, as well as the inlet and outlet 12 and 14. These pinch clamps 46 allow regulation and control of fluid flow through the priming loop 70 and fluid circuit 16.

[0048] As FIG. 3B shows, priming solution is drawn (by the fluid circuit pump P in the inlet line 12) through the second tubing assembly 44 from the priming container 32 and into the fluid circuit 16. Residual air occupying the fluid circuit 16 is displaced by the priming solution and returned with the priming solution through the first tubing assembly 40 back into the priming container 32. Because the opening 50 of the first fluid passage 36 (conveying air and fluid into the container 32) is located at a higher gravity height than the opening 52 of the second fluid passage 38 (conveying fluid out of the container 32), air in the fluid outflow discharged by the first fluid passage 36 is not drawn or sucked into the fluid inflow entering the second fluid passage 38. Instead, the air floats upward, away from the second fluid passage 38 and is collected in the air space 72 at the top of the container 32. This permits the fluid circuit 16 to be primed with fluid contained in the priming container 32, while virtually all air is expelled from the fluid circuit 16 and trapped in the air space 72 in the priming container 32. This procedure removes all air from the system 10.

[0049] The pump P may continue to operate in this fashion until steps are taken to begin fluid processing. For example, when the fluid circuit 16 is being used to conduct hemofiltration, the pump P can be operated to continuously recirculate the priming fluid from the container 32 through the circuit 16, until the patient is available for attachment to the fluid circuit 16.

[0050] In a preferred embodiment (see FIG. 5), the fluid circuit 16 is supplied to the operator with the connector 30 releasably preconnected to the circuit 16 by the connectors 66/64 and 62/42. In this arrangement, the connector 30 is enclosed in a sterile manner within a cap 80, which maintains its sterility prior to use. When supplied to the operator,

the pinch clamps 46 provided upstream and downstream of the connectors 66/64 and 62/42 are preferably open.

[0051] Priming of the fluid circuit 10 commences with the removal of the cap 80 and coupling the connector 30 to the priming container 32 (see FIG. 2). The pump P is operated in a forward flow condition to draw fluid from the priming container 32 and push air into the priming container 32 (as shown in FIG. 3B). The priming solution is circulated in this manner in the loop 70 until priming solution fills the fluid circuit 16 and all air is expelled and collected in the air space 72 at the top of the priming container 32.

[0052] A flow restrictor 74 can be placed in the first tubing assembly 40 or in the first fluid passage 36. The flow restrictor 74 helps to create a positive back pressure at the outlet 14, to facilitate complete priming of the hemofilter HF (or other blood processing device the system 10 may incorporate).

[0053] Once the fluid circuit 16 is primed, operation of the pump P is terminated, and all pinch clamps 46 are closed. The operator disconnects the connector 62 from the connector 42. The free connector 62 on the outlet 14 is, in turn, coupled to the outgoing fluid access line 24. While the connection of the outlet 14 to the outgoing fluid access line 24 occurs, the female-to-female connector 60 is left attached to the male luer 58 of the connector 42, to serve as a cap for the male luer 58. As a cap, the connector 60 covers the male luer 58 on the first tubing assembly 40, to maintain its sterility while the inlet 12 of the fluid circuit 16 is disconnected from the second tubing assembly 44.

[0054] To disconnect the inlet 12 of the fluid circuit 16 from the second tubing assembly 44, the operator disconnects the connector 66 from connector 64. The free connector 66 on the inlet 12 is, in turn, coupled to the incoming fluid access line 22. The system 10 is now in the condition for use shown in FIG. 1.

[0055] The female-to-female connector 60 is now removed to expose the male luer 58 of the first tubing assembly 40. The connector 60 can now be discarded. The male luer 58 can then be connected with the female luer 64 on the second tubing assembly 44 (see FIG. 3C). The closed loop 68 is thereby formed between the first and second tubing assemblies 40 and 44, through the priming container 32, to maintain sterility within the connector 30 and tubing assemblies 40 and 44 until the rinse-back function is performed. When the closed loop 68 is formed, the clamps 46 in the tubing assemblies 40 and 44 may be closed.

[0056] The clamps 46 on inlet and outlet lines 12 and 14 and the incoming and outgoing fluid access lines 22 and 24 can be opened. Operation of the pump P begins, and the primed fluid circuit 16 processes blood and fluid in the desired manner (e.g., hemofiltration).

[0057] B. Rinse-back Function

[0058] The rinse-back function is performed at the end of the blood processing session. The rinse-back function is illustrated in FIG. 4.

[0059] After blood processing, the outgoing fluid access assembly 24 is left connected to the outlet 14, to return residual fluid from the fluid circuit 16 to the individual during the rinse-back function. The operator disconnects the male luer 58 on the first tubing assembly 40 from the female

luer 64 on the second tubing assembly 44, to interrupt the loop 58. The clamps 46 on the incoming fluid access assembly 22 and inlet 12 are closed. The incoming fluid access assembly 22 is disconnected from the inlet 12. The female luer 64 of the second tubing assembly 44 is coupled to male luer 66 on the inlet 12.

[0060] The pinch clamps 46 in the second tubing assembly 44 and the inlet 12 are opened (the pinch clamp 46 on the first tubing assembly 40 remains closed). Subsequent operation of the pump P draws priming solution from the container 32 into and through the fluid circuit 16. In this process, residual blood remaining in the fluid circuit 16 is effectively rinsed or flushed from the circuit 16 and ultimately returned to the individual through the outgoing fluid access assembly 24. This reduces the amount of blood loss by the individual.

[0061] At the end of the rinse-back function, the operator disconnects the outlet 14 from the outgoing fluid access assembly 24. The system 10, which includes the fluid circuit 16 connected by the connector 30 to the priming container 32, can now be discarded as a unit.

[0062] The arrangement as described performs both a priming function and a rinse back function using the same connector assembly and the same source of solution.

[0063] III. Other Embodiments

[0064] The fluid priming assembly 26 can be constructed in various alternative ways.

[0065] For example, as shown in FIG. 6A, a fluid priming assembly 28 comprises the priming container 32 that is supplied to the operator with the first and second tubing assemblies 40 and 44 attached as individual lengths of flexible tubing integrally coupled directly to priming container 32, without use of the intermediate dual lumen connector 30. Each tubing length 40 and 44 includes its own luer connector, respectively 42 and 64, and an upstream pinch clamp 46, which is closed at the time it is supplied to the operator. At time of use (as FIG. 6B shows), the first tubing assembly connector 42 can be coupled the connector 62 of the outlet 14, and the second tubing assembly connector 64 is coupled to the connector 66 of the inlet 12. Alternatively, the container 32 with preconnected first and second tubing assemblies can be supplied to the operator releasably pre-connected to the fluid circuit 16 in the manner shown in FIG. 6B.

[0066] Once the components are assembled as shown in FIG. 6B, the pinch clamps 46 can be opened and the pump P operated in the manner as previously discussed, to draw fluid from the priming container 32 and push air into the priming container 32, thereby priming the fluid circuit 16. Subsequent manipulation of the first and second tubing assemblies 40 and 44 and priming container 32, to enable fluid processing in the fluid circuit 16 after priming, as well as to conduct a rinse back function after fluid processing, is carried out in the same manner as discussed with regard to the configuration shown in FIG. 5.

[0067] Alternatively, as shown in FIG. 7, a fluid priming assembly 28 comprises the first and second tubing assemblies 40 and 44 taking the form of individual lengths of flexible tubing coupled directly to priming container 32 at time of use by means of separate connectors 82 and 84. The connectors 82 and 84 can take the form of luer fittings or, as

shown in FIG. 7, spikes that penetrate separate port tube membranes 86 on the priming container 32. As FIG. 7 shows, the two connectors 82 and 84 (desirably enclosed within caps 80) can be supplied to the operator releasably preconnected to the circuit 16 by the connectors 66/64 and 62/42, in the same manner as the single connector 30 shown in FIG. 5. After coupling the dual connectors 82 and 84 to the priming container 32 at time of use (as indicated by arrows in FIG. 7), the manipulation of the first and second tubing assemblies 40 and 44 in FIG. 7 to carry out the priming and rinse back functions is the same as discussed with regard to the single connector configuration shown in FIG. 5.

[0068] In another alternative embodiment (see FIG. 8), the fluid that the container 32 carries can comprise the replacement fluid that is added to make up for fluid lost during toxin removal. In this arrangement, the inlet 18 includes a connector 90 that releasably couples to a mating connector 88 carried by a third tubing assembly 92, which is itself coupled directly to the container 32. The third tubing assembly 92 can be coupled to the container 32 in the same manner as the first and second tubing assemblies 40 and 44, i.e., either by integral coupling or by use of instant-of-use luer or spike connectors. In this arrangement, the tubing assemblies 40 and 44 convey the replacement fluid to perform a priming and rinse back function at the beginning and end of fluid processing, as previously described, while the third tubing assembly 92 conveys replacement fluid during fluid processing. In this arrangement, the container 32 can comprise a container prefilled with replacement fluid, or it can comprise a reservoir that receives replacement fluid from a sterile fluid generating source during fluid processing. The sterile fluid can be generated, e.g., by treating water from an external source or (as FIG. 8 shows) by sterile filtering the fluid waste product of the fluid circuit 16 itself in a replacement fluid generation device 94, e.g., of a type disclosed in application Ser. No. 09/027,301 filed Feb. 19, 1998 and entitled "Hemofiltration System Including Ultrafiltrate Purification and Reinfusion System," which is incorporated herein by reference.

[0069] Features and advantages of the invention are set forth in the following claims.

We claim:

1. A connector comprising
 - a body constructed for coupling to a fluid source,
 - a first fluid passage in the body,
 - a second fluid passage in the body that does not communicate with the first fluid passage,
 - a first assembly communicating with the first fluid passage and including a first fitting to releasably couple the first fluid passage to an outlet of a fluid circuit and to convey fluid only through the first fluid passage, and
 - a second assembly communicating only with the second fluid passage and including a second fitting to releasably couple the second fluid passage to an inlet of the fluid circuit, whereby fluid can be circulated through the fluid source in a loop that includes the fluid circuit to collect in the fluid source air residing in the fluid circuit.
2. A connector according to claim 1, wherein one end of the connector body is tapered to form a spike.
3. A connector according to claim 1, wherein at least one of the first and second assemblies includes a luer fitting.
4. A connector according to claim 1, wherein at least one of the first and second assemblies includes an in-line clamp.
5. A connector according to claim 1 wherein the first and second fittings are constructed and arranged to releasably couple the first assembly to the second assembly when the first and second fittings are disconnected, respectively, from the outlet and inlet of the fluid circuit.
6. A connector according to claim 1 further including a removable cap enclosing the body prior to use.
7. A connector according to claim 1 wherein the body includes a distal end communicating with the fluid source, wherein the first and second fluid passages each exits the distal end, and wherein the first fluid passage exits the distal end of the body at a higher gravity height that the second fluid passage exits the distal end.
8. A connector according to claim 1 wherein the body comprises a tubular member.
9. A connector according to claim 8 wherein the tubular member includes a distal end that is angled to form a spike.
10. A connector according to claim 8 wherein the first fluid passage exits the distal end of the tubular member at a higher gravity height than the second fluid passage.
11. A fluid processing system comprising a fluid circuit including an inlet and an outlet, and a connector assembly constructed for coupling to a fluid source, the connector assembly including a first fluid passage coupled to the outlet of the fluid circuit and a second fluid passage that does not communicate with the first fluid passage and is coupled to the inlet of the fluid circuit, whereby fluid can be circulated by the connector assembly through the fluid source in a loop that includes the fluid circuit to collect in the fluid source air residing in the fluid circuit.
12. A system according to claim 11 wherein the connector assembly is integrally coupled to the fluid source.
13. A system according to claim 11 wherein the connector assembly is releasably attachable to the fluid source.
14. A system according to claim 11 wherein the connector assembly includes a first connector body that includes the first fluid passage and a second

- connector body that is separate from the first connector body and that includes the second fluid passage.
- 15.** A system according to claim 14
- wherein at least one of the first and second connector bodies comprises a luer fitting.
- 16.** A system according to claim 14
- wherein at least one of the first and second connector bodies is tapered to form a spike.
- 17.** A system according to claim 14
- further including a removable cap enclosing at least one of the first and second connector bodies prior to use.
- 18.** A system according to claim 11
- wherein the connector assembly includes a single connector body that includes both the first and second fluid passages.
- 19.** A system according to claim 18
- further including a removable cap enclosing the single connector body prior to use.
- 20.** A system according to claim 11
- wherein at least one of the first and second fluid passages includes an in-line clamp.
- 21.** A system according to claim 11
- wherein the fluid circuit includes a blood processing element.
- 22.** A system according to claim 11
- wherein the fluid circuit includes a filter.
- 23.** A system according to claim 22
- wherein the filter comprises a hemofilter that, in use, removes toxins from blood.
- 24.** A system according to claim 11
- wherein the fluid circuit comprises at least a portion of a hemofiltration system.
- 25.** A system according to claim 11
- wherein the fluid circuit comprises at least a portion of a hemodialysis system.
- 26.** A system according to claim 11
- wherein the fluid circuit forms at least a portion of a hemodiafiltration system.
- 27.** A system according to claim 11
- wherein the fluid circuit forms at least a portion of a dialysis system.
- 28.** A system according to claim 11
- wherein the fluid circuit forms at least a portion of a peritoneal dialysis system.
- 29.** A fluid processing apparatus comprising
- a fluid container, and
- a connector assembly coupled to the fluid container, the connector assembly including a first fluid passage releasably coupled by a luer connector to an outlet of a fluid circuit and a second fluid passage that does not communicate with the first fluid passage and releasably coupled by a luer connector to an inlet of the fluid circuit, whereby fluid can be circulated by the connector assembly through the fluid container in a loop that includes the fluid circuit to collect in the fluid source air residing in the fluid circuit.
- 30.** An apparatus according to claim 29
- wherein at least one of the first and second fluid passages includes an in-line clamp.
- 31.** An apparatus according to claim 29
- wherein the apparatus comprises at least a portion of a blood processing system.
- 32.** An apparatus according to claim 29
- wherein the apparatus comprises at least a portion of a hemofiltration system.
- 33.** An apparatus according to claim 29
- wherein the apparatus comprises at least a portion of a hemodialysis system.
- 34.** An apparatus according to claim 29
- wherein the apparatus forms at least a portion of a hemodiafiltration system.
- 35.** An apparatus according to claim 29
- wherein the apparatus forms at least a portion of a dialysis system.
- 36.** An apparatus according to claim 29
- wherein the apparatus forms at least a portion of a peritoneal dialysis system.
- 37.** A fluid processing system comprising
- a fluid circuit including an inlet and an outlet, and
- a connector comprising a body constructed for coupling to a fluid source, a first fluid passage in the body coupled to the outlet of the fluid circuit, and a second fluid passage in the body that does not communicate with the first fluid passage and coupled to the inlet of the fluid circuit, whereby fluid can be circulated through the fluid source in a loop that includes the fluid circuit to collect in the fluid source air residing in the fluid circuit.
- 38.** A system according to claim 37
- wherein one end of the connector body is tapered to form a spike.
- 39.** A system according to claim 37
- further including an in-line clamp between at least one of the outlet and inlet and the respective first and second fluid passage.
- 40.** A system according to claim 37
- further including a removable cap enclosing the body prior to use.
- 41.** A system according to claim 37
- wherein the fluid circuit includes a blood processing element.
- 42.** A system according to claim 37
- wherein the fluid circuit includes a filter.
- 43.** A system according to claim 42
- wherein the filter comprises a hemofilter that, in use, removes toxins from blood.
- 44.** A system according to claim 37
- wherein the fluid circuit comprises at least a portion of a hemofiltration system.
- 45.** A system according to claim 37
- wherein the fluid circuit comprises at least a portion of a hemodialysis system.

46. A system according to claim 37

wherein the fluid circuit forms at least a portion of a hemodiafiltration system.

47. A system according to claim 37

wherein the fluid circuit forms at least a portion of a dialysis system.

48. A system according to claim 37

wherein the fluid circuit forms at least a portion of a peritoneal dialysis system.

49. A system according to claim 37

wherein the connector includes a first assembly communicating with the first fluid passage to couple the first fluid passage to the outlet and convey fluid only through the first fluid passage.

50. A system according to claim 49

wherein the first assembly includes an in-line clamp.

51. A system according to claim 49

wherein the first assembly includes a fitting releasably coupled to the outlet.

52. A system according to claim 51

wherein the fitting comprises a luer fitting.

53. A system according to claim 37

wherein the connector includes a second assembly communicating with the second fluid passage to couple the second fluid passage to the inlet and convey fluid only through the second fluid passage.

54. A system according to claim 53

wherein the second assembly includes an in-line clamp.

55. A system according to claim 53

wherein the second assembly includes a fitting releasably coupled to the inlet.

56. A system according to claim 55

wherein the fitting comprises a luer fitting.

57. A system according to claim 37

wherein the connector includes a first assembly communicating with the first fluid passage to couple the first fluid passage to the outlet and convey fluid only through the first fluid passage, and a second assembly communicating with the second fluid passage to couple the second fluid passage to the outlet and convey fluid only through the second fluid passage.

58. A system according to claim 57

wherein at least one of the first and second assemblies includes a fitting releasably coupled to the respective outlet and inlet.

59. A system according to claim 57

wherein the first assembly includes a first fitting releasably coupled to the outlet, and

wherein the second assembly includes a second fitting releasably coupled to the inlet.

60. A system according to claim 59

wherein at least one of the first and second fitting comprises a luer fitting.

61. A system according to claim 57

wherein the first and second fittings releasably couple together when disconnected from the respective outlet and inlet.

62. A system according to claim 37

wherein the first fluid passage communicates with the fluid source at a higher gravity height than the second fluid passage.

63. A system according to claim 37

wherein the body comprises a tubular member.

64. A system according to claim 63

wherein the tubular member includes a distal end that is tapered to form a spike.

65. A system according to claim 64

wherein the first fluid passage exits the distal end at a higher gravity height than the second fluid passage.

66. A method for priming a fluid circuit comprising the steps of

coupling a connector assembly to a fluid reservoir, the connector assembly comprising a first fluid passage and a second fluid passage,

circulating fluid in the fluid circuit through the fluid reservoir by conveying fluid into an inlet of the fluid circuit from the reservoir through the second fluid passage while conveying fluid from an outlet of the fluid circuit into the reservoir through the first fluid passage, and

during the circulation step, accumulating air residing in the fluid circuit in the fluid reservoir, thereby removing air from the fluid circuit.

67. A method according to claim 66

further including the steps of coupling the first fluid passage to the outlet of the fluid circuit and coupling the second fluid passage to the inlet of the fluid circuit.

68. A method according to claim 66

further including the steps of releasably coupling the first fluid passage to the outlet of the fluid circuit and releasably coupling the second fluid passage to the inlet of the fluid circuit.

69. A method according to claim 66

further including the step of coupling the first and second passages together after the accumulating step.

70. A method according to claim 66

wherein the circulating step includes conveying fluid into the fluid reservoir at a higher gravity height than fluid is conveyed from the fluid reservoir.

71. A method according to claim 66

wherein the connector assembly comprises a single connector body that includes both the first and second fluid passages.

72. A method according to claim 66

wherein the connector assembly includes a first connector body that includes the first fluid passage and a second connector body that includes the second fluid passage.

73. A method according to claim 66

further including the step of enclosing the connector assembly prior to use.

74. A method according to claim 66

wherein the fluid circuit includes a blood processing element.

75. A method according to claim 66

wherein the fluid circuit includes a filter.

76. A method according to claim 75

wherein the filter comprises a hemofilter that, in use, removes toxins from blood.

77. A method according to claim 66

wherein the fluid circuit comprises at least a portion of a hemofiltration system.

78. A method according to claim 66

wherein the fluid circuit comprises at least a portion of a hemodialysis system.

79. A method according to claim 66

wherein the fluid circuit forms at least a portion of a hemodiafiltration system.

80. A method according to claim 66

wherein the fluid circuit forms at least a portion of a dialysis system.

81. A method according to claim 66

wherein the fluid circuit forms at least a portion of a peritoneal dialysis system.

82. A method according to claim 66

wherein the coupling step includes inserting the connector assembly through a port tube membrane on the fluid reservoir.

83. A method according to claim 66

wherein the connector assembly comprises a tubular body.

84. A method according to claim 83

wherein the tubular body includes a distal end having a taper to form a spike.

85. A method according to claim 66

further including, after the accumulating step, coupling the inlet of the fluid circuit to a blood access site.

86. A method according to claim 66

further including, after the accumulating step, coupling the outlet of the fluid circuit to a blood access site.

87. A method for priming and flushing a fluid circuit comprising the steps of

providing a connector assembly comprising a first fluid passage releasably coupled to an outlet of the fluid circuit and a second fluid passage releasably coupled to an inlet of the fluid circuit,

coupling the connector assembly to a fluid reservoir,

priming the fluid circuit through the fluid reservoir by conveying fluid into the inlet of the fluid circuit from the reservoir through the second fluid passage while conveying fluid from the outlet of the fluid circuit into the reservoir through the first fluid passage,

after the priming step, releasing the coupling between the connector assembly and the inlet and outlet of the fluid circuit while keeping the connector assembly coupled to the fluid reservoir,

processing a selected fluid using the fluid circuit,

after the processing step, coupling the inlet of the fluid circuit to the second fluid passage, and

rinsing residue of the selected fluid from the fluid circuit by conveying fluid into the inlet of the fluid circuit from the reservoir through the second fluid passage, while conveying the selected fluid residue from the outlet of the fluid circuit in a path that bypasses the reservoir.

88. A method according to claim 87

further including the step of accumulating air residing in the fluid circuit in the fluid reservoir during the priming step, thereby removing air from the fluid circuit.

89. A method according to claim 87

wherein, during the processing step, the first and second fluid passages are coupled together in a loop.

* * * * *