

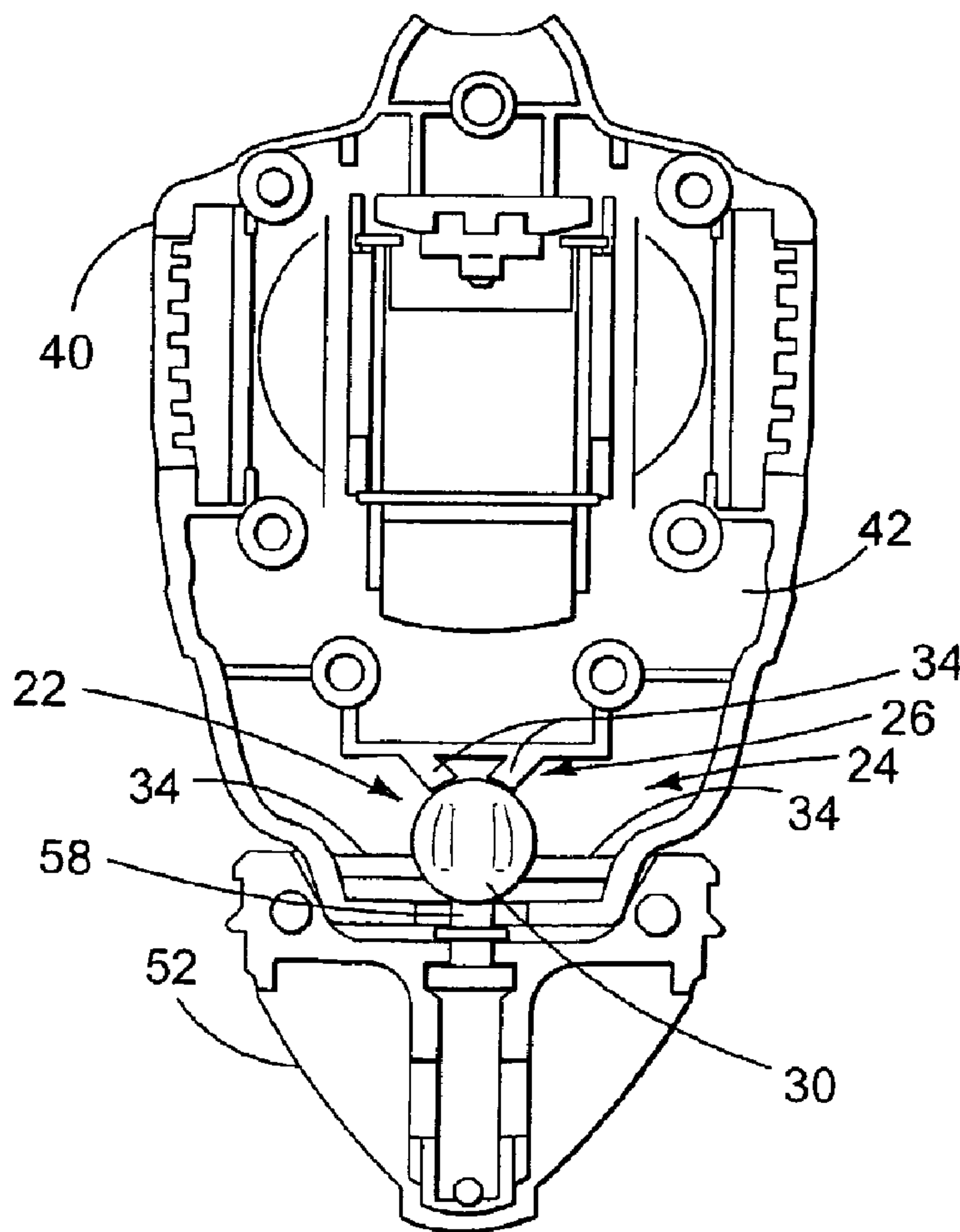

(86) Date de dépôt PCT/PCT Filing Date: 2003/11/12
 (87) Date publication PCT/PCT Publication Date: 2004/05/27
 (45) Date de délivrance/Issue Date: 2009/02/03
 (85) Entrée phase nationale/National Entry: 2005/05/06
 (86) N° demande PCT/PCT Application No.: US 2003/036361
 (87) N° publication PCT/PCT Publication No.: 2004/043562
 (30) Priorité/Priority: 2002/11/12 (US60/426,021)

(51) Cl.Int./Int.Cl. *A63H 3/46* (2006.01)
 (72) Inventeur/Inventor:
 WAI, FUK CHAI ALVIN, CN
 (73) Propriétaire/Owner:
 MATTEL, INC., US
 (74) Agent: OGILVY RENAULT LLP/S.E.N.C.R.L.,S.R.L.

(54) Titre : JOINT A FROTTEMENT POUR JOUETS
 (54) Title: FRICTIONAL JOINT FOR TOYS



(57) Abrégé/Abstract:

Joints (14) for movable toys, such as action figures (10), that use friction to maintain a fixed position. The toys include several body part members (16, 18) interconnected by a joint (14) that includes a plug portion (22) and a socket portion (24) that receives the

(57) **Abrégé(suite)/Abstract(continued):**

plug portion (22). The socket portion (24) includes one or more protrusions (34), against which the plug portion (22) is urged to create friction between the plug portion (22) and the socket portion (24).

(12) INTERNATIONAL APPLICATION PUBLISHED UNDER THE PATENT COOPERATION TREATY (PCT)

(19) World Intellectual Property
Organization
International Bureau



(43) International Publication Date
27 May 2004 (27.05.2004)

PCT

(10) International Publication Number
WO 2004/043562 A1

(51) International Patent Classification⁷: **A63H 3/46**

Alvin [CN/CN]; 1A, 10th Lane, Sha Kok Mei Village, Sai Kung, N.T., Kowloon, Hong Kong (CN).

(21) International Application Number:
PCT/US2003/036361

(74) Agent: **TUTTLE, Christopher, S.**; Kolisch Hartwell, P.C., 520 S.W. Yamhill Street, Suite 200, Portland, OR 97204 (US).

(22) International Filing Date:
12 November 2003 (12.11.2003)

(81) Designated States (*national*): AE, AG, AL, AM, AT, AU, AZ, BA, BB, BG, BR, BY, BZ, CA, CH, CN, CO, CR, CU, CZ, DE, DK, DM, DZ, EC, EE, EG, ES, FI, GB, GD, GE, GH, GM, HR, HU, ID, IL, IN, IS, JP, KE, KG, KP, KR, KZ, LC, LK, LR, LS, LT, LU, LV, MA, MD, MG, MK, MN, MW, MX, MZ, NI, NO, NZ, OM, PG, PH, PL, PT, RO, RU, SC, SD, SE, SG, SK, SL, SY, TJ, TM, TN, TR, TT, TZ, UA, UG, US, UZ, VC, VN, YU, ZA, ZM, ZW.

(25) Filing Language: English

(26) Publication Language: English

(30) Priority Data:
60/426,021 12 November 2002 (12.11.2002) US

(71) Applicant (*for all designated States except US*): **MATTEL, INC.** [US/US]; 333 Continental Boulevard, El Segundo, CA 90245 (US).

(84) Designated States (*regional*): ARIPO patent (BW, GH, GM, KE, LS, MW, MZ, SD, SL, SZ, TZ, UG, ZM, ZW), Eurasian patent (AM, AZ, BY, KG, KZ, MD, RU, TJ, TM), European patent (AT, BE, BG, CH, CY, CZ, DE, DK, EE, ES, FI, FR, GB, GR, HU, IE, IT, LU, MC, NL, PT, RO, SE,

(72) Inventor; and

(75) Inventor/Applicant (*for US only*): **WAI, Fuk, Chai,**

[Continued on next page]

(54) Title: FRICTIONAL JOINT FOR TOYS

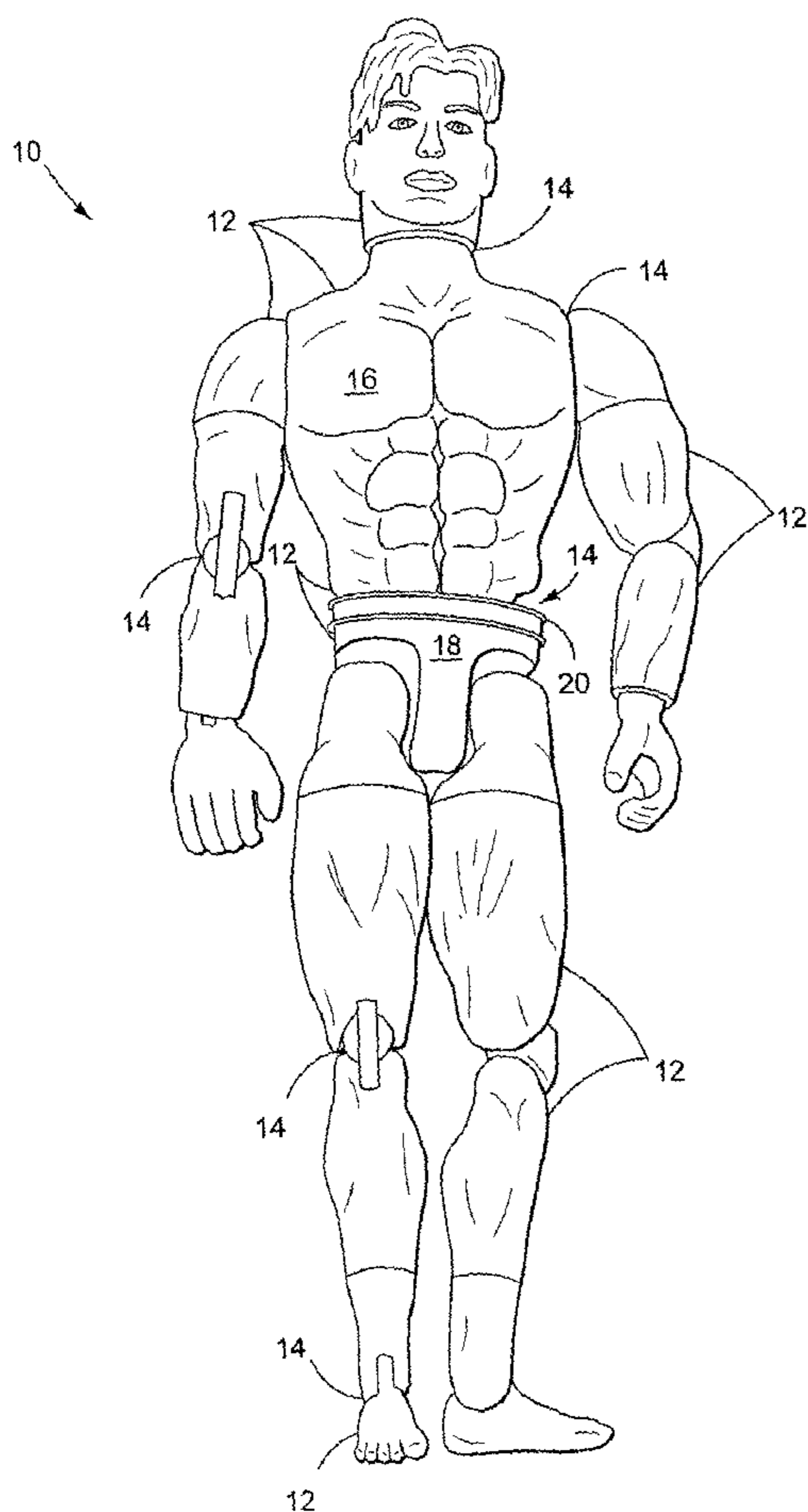

(57) Abstract: Joints (14) for movable toys, such as action figures (10), that use friction to maintain a fixed position. The toys include several body part members (16, 18) interconnected by a joint (14) that includes a plug portion (22) and a socket portion (24) that receives the plug portion (22). The socket portion (24) includes one or more protrusions (34), against which the plug portion (22) is urged to create friction between the plug portion (22) and the socket portion (24).

WO 2004/043562 A1

WO 2004/043562 A1



SI, SK, TR), OAPI patent (BF, BJ, CF, CG, CI, CM, GA, GN, GQ, GW, ML, MR, NE, SN, TD, TG).

For two-letter codes and other abbreviations, refer to the "Guidance Notes on Codes and Abbreviations" appearing at the beginning of each regular issue of the PCT Gazette.

Published:

- *with international search report*
- *before the expiration of the time limit for amending the claims and to be republished in the event of receipt of amendments*

FRictionAL JOINT FOR TOYS

Background

[0001] The present disclosure relates generally to movable toys, and more specifically, to joints of action figures and dolls. Movable action figures and dolls
5 (e.g., action figures having shoulder/elbow joints, hip/knee joints, waist joints, etc.) can provide imaginative fun for children. Movable joint motion allows a child to configure a toy as he or she chooses. Examples of such toys are disclosed in U. S. Patent Nos. 3,277,602; 3,628,282; 3,988,855; 4,274,224; 4,968,282; 5,989,658; and 6,435,938. Typically, it is desirable that the joints and other structures which enable
10 relative movement be durable, enable the desired range of movement, and be relatively inexpensive to manufacture.

Summary

[0002] The present disclosure is directed to a movable toy, such as a doll or action figure, having a joint or like mechanism that enables relative movement. In some
15 embodiments, the toy includes two or more body part members interconnected by a joint having a plug and a socket for receiving the plug. The socket includes one or more protrusions, against which the plug is urged to create friction between the plug and socket, thereby restricting joint motion.

Brief Description of the Drawings

20 [0003] Fig. 1 depicts an embodiment of a movable toy according to the present description.

[0004] Fig. 2 is a cross-sectional exploded view of the movable toy of Fig. 1, showing components of the toy that are movably interconnected by a joint according to the present description.

[0005] Fig. 3 is a detailed exploded view of the joint shown in Fig. 2.

5 [0006] Fig. 4 is a cross-sectional view of the components of Fig. 2 assembled.

[0007] Fig. 5 is a cross-sectional view similar to Fig. 4, but showing an alternate embodiment of a joint according to the present description.

Detailed Description

[0008] Fig. 1 depicts a toy 10 according to the present description. In the
10 depicted example, toy 10 is implemented as an action figure having several body part members 12 with movable interconnections between the members. These movable interconnections take the form of joints 14 defined between body part members 12. The joints enable the various body part members to be moved relative to one another in various ways.

15 [0009] Typically, a given joint is configured to enable one part of the toy (e.g., a body part member) to be moved relative to another, and then maintain the relative position of the parts once a desired position has been achieved. For example, toy 10 has a first body part member, such as torso 16, and a second body part member, such as pelvis 18. One of joints 14 forms a waist joint 20, defined between torso 16 and
20 pelvis 18 to enable relative motion between the torso and pelvis. The remaining description will focus primarily on the waist joint, though it should be appreciated that the structures and mechanisms to be discussed may be implemented in other locations on a doll, and in movable toys other than dolls.

[0010] As shown in Figs. 2-5, joint 20 may include a plug portion or assembly 22, and a socket portion or assembly 24 that receives plug 22. Plug portion 22 is formed on one of the first and second body part members, such as on pelvis 18, while socket portion 24 is formed on the other of the first and second body part members, such as on torso 16. Socket portion 24 includes a friction assembly 26 that inhibits relative movement between plug portion 22 and socket portion 24. Friction is produced between multiple socket contact regions 28 and plug contact regions 30, also referred to as the operative surface of plug portion 22. In the depicted examples, contact regions are formed on a spherical head of plug portion 22, though it should be appreciated that other shapes and configurations may be employed.

[0011] In some embodiments, socket portion 24 has a support surface or wall portion 32 with several protrusions 34 extending therefrom that form socket contact regions 28. Joint 14 may be adapted so that plug portion 22 is urged into contact with protrusions 34 so as to create friction therebetween. The body part members are therefore able to maintain their relative positions during play.

[0012] As previously mentioned, joint 14 is comprised of socket portion 24 and plug portion 22. These portions engage with one another to control relative movement between torso 16 and pelvis 18 (e.g., by inhibiting relative movement through friction), or other appropriate body part members 12. Plug contact region 30 articulates within socket portion 24. In some embodiments, plug contact region 30 is spherical and mates with a cylindrically shaped socket portion, as shown in Figs. 2-4. Alternatively, only part of plug portion 22 may be convex and used as a contact region.

[0013] In some embodiments, such as shown in Figs. 2-4, socket portion 24 includes a socket insert 36. This insert may be useful in retaining plug portion 22 captured and held within socket portion 24 and increasing the frictional surface contact between socket portion 24 and plug portion 22. In other embodiments, as
5 shown in Fig. 5, socket insert 36 is replaced by additional protrusions 34, or extension of the existing lateral protrusions, thus reducing the number of overall components needed to assemble toy 10.

[0014] In the depicted examples, insert 36 has an opening sized to accommodate passage of a shaft 58 that extends away from head 30 of plug portion 22. Typically,
10 the opening is smaller than the diameter of head 30, so as to maintain the head captured and held within socket portion 24. Also, the area around the opening typically is adapted to contact the head of plug portion 24 and urge it toward the frictional contact surfaces of the socket.

[0015] Socket portion 24 typically includes one or more protrusions 34 extending
15 inward toward the head of plug portion 22. The protrusions may be formed on the torso of the doll, as indicated in the figure, or may be manufactured as a separate piece to be inserted during assembly. Protrusions 34 typically are adapted to provide the friction described above, so as to inhibit movement (e.g., rotation) of plug portion 22 within socket portion 24, thereby inhibiting relative movement of the respective
20 members of the toy (e.g., body part members 12). As shown in Figs. 2-5, protrusions 34 may take the form of ribs having contact regions 28 configured to correspond to plug contact region 30. The protrusions shown in Figs. 2-4 have ends that are angled opposite one another to form a V-shaped seat that straddles and receives the head of

plug portion 22. Alternatively, or additionally, contact regions 28 may be concave to provide increased contact with at least a portion of the convex contact region of plug portion 22, as shown in Fig. 5.

[0016] The protrusions themselves may also be aligned towards one another so that the protrusions approach operative surface 30 from different directions, or they may extend parallel to one another from the socket wall. Furthermore, the ends of the protrusions may be angled or formed with a concave contour to complement the concave operative surface of the head of plug portion 22. In addition, the head of the plug portion may be provided with grooves for receiving the protrusions, so as to provide desired constraints on the relative movement permitted between the parts of the toy.

[0017] As shown in Fig. 2, torso 16 may be subdivided into a torso front 38 and a torso back 40 that define an internal compartment 42. Internal compartment 42 may provide space for the joint components, so as to conceal the joint components and/or protect the components. Accordingly, in the depicted example, torso 16 is configured to conceal at least plug portion 22 and protrusions 34. The section of torso 16 nearest pelvis 18 forms a tapered base, or pelvis mating region 44, which allows a lower end of torso 16 to be recessed within pelvis 18, as shown in Figs. 4 and 5.

[0018] Socket portion 24 may have additional structure to secure socket insert 36 within its respective body part member 12. As shown in Figs. 3 and 4, socket insert 36 has a flange 46 that anchors socket insert 36 to torso 16 within internal torso compartment 42. As indicated, flange 46 may rest between plates 48 located in pelvis

mating region 44 of torso 16 and may thereby be restricted from translating out of alignment once torso front 38 and torso back 40 are joined together.

[0019] Similar to torso 16, pelvis 18 may be formed from a pelvis front 50 and a pelvis back 52 that form an internal pelvis compartment 54, as shown in Fig. 2. Pelvis 5 18 further includes a cupped surface 56, which receives pelvis mating region 44 of torso 16, thereby concealing portions of joint 20.

[0020] Plug portion 22 may be anchored to the body part member opposite that in which socket portion 24 is mounted, such as to pelvis 18. As shown in Fig. 3, plug portion 22 may have a shaft 58 extending from a head 30 of the plug portion. At the 10 end of shaft 58, opposite plug contact region 30, an anchor 60 may be provided to secure the plug portion to pelvis 18, via plug flange 62. Referring to Fig. 4, flange 62 secures plug portion 22 to pelvis 18 by engagement with a pelvis plate 64 located within pelvis 18. As shown, shaft 58 has two flanges 62 that straddle a single pelvis plate 64. Alternatively, pelvis 18 may have a pair of plates, between which a single 15 flange on shaft 58 rests.

[0021] In Fig. 4, at least some of plug portion 22 may extend through an aperture 66 of socket portion 24, such as via shaft 58. Torso plates 48 and pelvis plates 64 typically have notches or other openings to provide a channel through the plates, for passage of shaft 58. This arrangement allows plug portion 22 to be mounted by one 20 end in pelvis 18 and the other end to be received by torso 16 for engagement with socket portion 24, as depicted in Fig. 4.

[0022] Once the components of toy 10 have been aligned in their appropriate positions, as previously discussed, the front and back portions of torso 16 and pelvis

18 are joined together using any suitable method, such as those generally known in the art. In some embodiments one half of a body part member includes pins or posts 68, while the other half of the body part member includes receptacles 70 that receive posts 68. In such a configuration, posts 68 are simply aligned with, and pressed into, 5 receptacles 70 to snap the two halves together.

[0023] It is believed that the disclosure set forth above encompasses multiple distinct inventions with independent utility. While each of these inventions has been disclosed in its preferred form, the specific embodiments thereof as disclosed and illustrated herein are not to be considered in a limiting sense as numerous variations 10 are possible. The subject matter of the inventions includes all novel and non-obvious combinations and subcombinations of the various elements, features, functions and/or properties disclosed herein. Similarly, where any claim recites "a" or "a first" element or the equivalent thereof, such claim should be understood to include incorporation of one or more such elements, neither requiring nor excluding two or more such 15 elements.

[0024] Inventions embodied in various combinations and subcombinations of features, functions, elements, and/or properties may be claimed through presentation of new claims in a related application. Such new claims, whether they are directed to a different invention or directed to the same invention, whether different, broader, 20 narrower or equal in scope to the original claims, are also regarded as included within the subject matter of the inventions of the present disclosure.

I CLAIM:

1. A movable toy, comprising:

a first body part member; and

a second body part member, wherein a joint is defined between the first and
5 second body part members to enable relative motion between the first and second
body part members, wherein the joint comprises:

a plug portion secured to one of the first and second body part members;

and

a socket portion secured to the other of the first and second body part
10 members and adapted to receive the plug portion, wherein the socket portion
includes:

multiple spaced apart protrusions, the joint being adapted so that
an operative surface of the plug portion is urged into contact with ends
of the protrusions so as to create friction therebetween; and

15 a separately manufactured removable insert adapted to secure the
plug portion within the socket portion.

2. The movable toy of claim 1, wherein one of the first and second body part
members includes a torso.

20

3. The movable toy of claim 2, wherein the other of the first and second body part
members includes a pelvis.

4. The movable toy of claim 1, wherein the protrusions are formed as ribs that extend toward the operative surface of the plug portion from a wall of the socket portion.

5 5. The movable toy of claim 4, wherein the ribs are angled towards one another so that the rib members extend toward the operative surface of the plug portion in different directions.

6. The movable toy of claim 4, wherein the ribs extend from the wall of the socket
10 portion parallel to one another.

7. The movable toy of claim 4, wherein the ribs form a seat adapted to receive a convex region of the operative surface of the plug portion, and wherein each rib has a concave end that conforms at least partially to the convex region of the operative
15 surface of the plug portion, such that when the plug portion is urged into contact with the ribs, relative movement between the body part members is inhibited by friction occurring between the concave ends of the ribs and the convex region of the plug portion.

20 8. The movable toy of claim 1, wherein the protrusions form a seat adapted to receive and center the operative surface of the plug portion thereupon.

9. The movable toy of claim 8, wherein the operative surface of the plug portion is convex and the protrusions each have a corresponding concave contact region.

10. The movable toy of claim 1, wherein the socket portion is formed separately
5 from the first and second body part members.

11. The movable toy of claim 10, wherein the plug portion includes a head and a shaft extending therefrom, the shaft being narrower in width than the head.

10 12. The movable toy of claim 11, wherein the shaft extends from the head through an opening in the removable insert, the opening being sized smaller than the head, such that the removable insert maintains the head captured and held within the socket portion while permitting the shaft to extend through the opening.

15 13. The movable toy of claim 12, wherein the insert is positioned so that an area of the removable insert surrounding the opening contacts the head of the plug portion and urges the head into engagement with the protrusions.

20 14. The movable toy of claim 1, wherein the plug portion has a head engaged with the protrusions and a shaft that extends away from the head between the first and second body part members.

15. The movable toy of claim 14, wherein an end of the shaft opposite the head has an anchor formed thereon, such anchor being adapted to secure the plug portion to one of the first and second body part members.

5 16. The movable toy of claim 1, wherein the first and second body part members are adapted to conceal the plug portion and the protrusions.

17. The movable toy of claim 1, wherein the plug portion includes a head which is captured and held within the socket portion, and wherein the plug portion further
10 includes a shaft that extends away from the head and out through an opening sized to accommodate passage of the shaft but prevent withdrawal of the head from the socket portion.

18. The movable toy of claim 17, wherein the head includes a convex contact
15 region which is urged into contact with ends of the spaced apart protrusions of the socket portion, and wherein such contact produces friction to thereby inhibit relative movement between the body part members.

19. A joint for a toy having multiple body part members, the joint comprising:
20 a plug portion; and
a socket portion adapted to receive the plug portion, including a friction assembly having multiple distinct contact regions that engage an operative surface of the plug portion, such that the friction assembly is adapted to produce friction between

the multiple distinct contact regions and the operative surface of the plug portion, to thereby inhibit relative movement between the plug portion and the socket portion, the socket portion also including a removable insert adapted to maintain the plug portion in frictional engagement with the socket portion.

5

20. The joint of claim 19, wherein each of the multiple contact regions are formed on an end of a protrusion that extends toward the operative surface of the plug portion.

10

21. The joint of claim 20, wherein the protrusions extend toward the operative surface of the plug portion at angles to one another.

22. The joint of claim 20, wherein the protrusions extend toward the operative surface of the plug portion parallel to one another.

15

23. The joint of claim 19, wherein the operative surface of the plug portion is convex and at least one of the multiple distinct contact regions is concave.

24. The joint of claim 19, wherein the socket portion is configured to capture and hold a head of the plug portion within the socket portion.

20

25. The joint of claim 24, wherein the socket portion is adapted to urge the head of the plug portion against the multiple distinct contact regions.

26. A movable toy, comprising:

a first member; and

a second member, wherein a joint is defined between the first and second members to enable relative motion between the first and second members, and

5 wherein the joint is a ball-and-socket joint in which a socket assembly with a removable insert secured to one of the members holds and captures a ball secured to the other of the members, the socket assembly further including multiple contact regions that contact an operative convex surface of the ball at spaced apart locations, and wherein such contact produces friction upon relative movement occurring
10 between the first and second members.

27. The movable toy of claim 26, wherein one of the members is a doll's torso.

28. The movable toy of claim 27, wherein the other of the members is a lower body
15 of the doll.

1/3

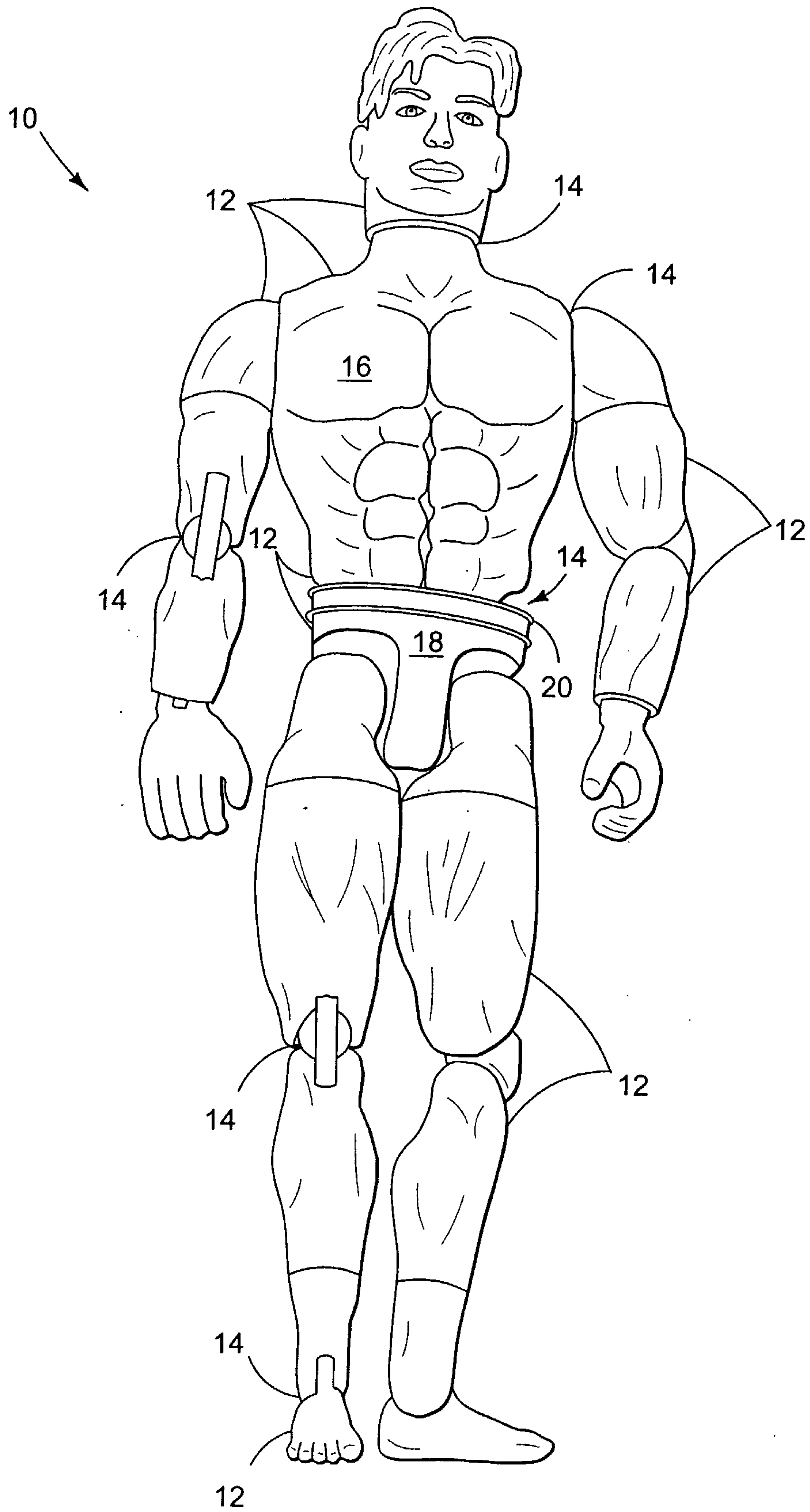
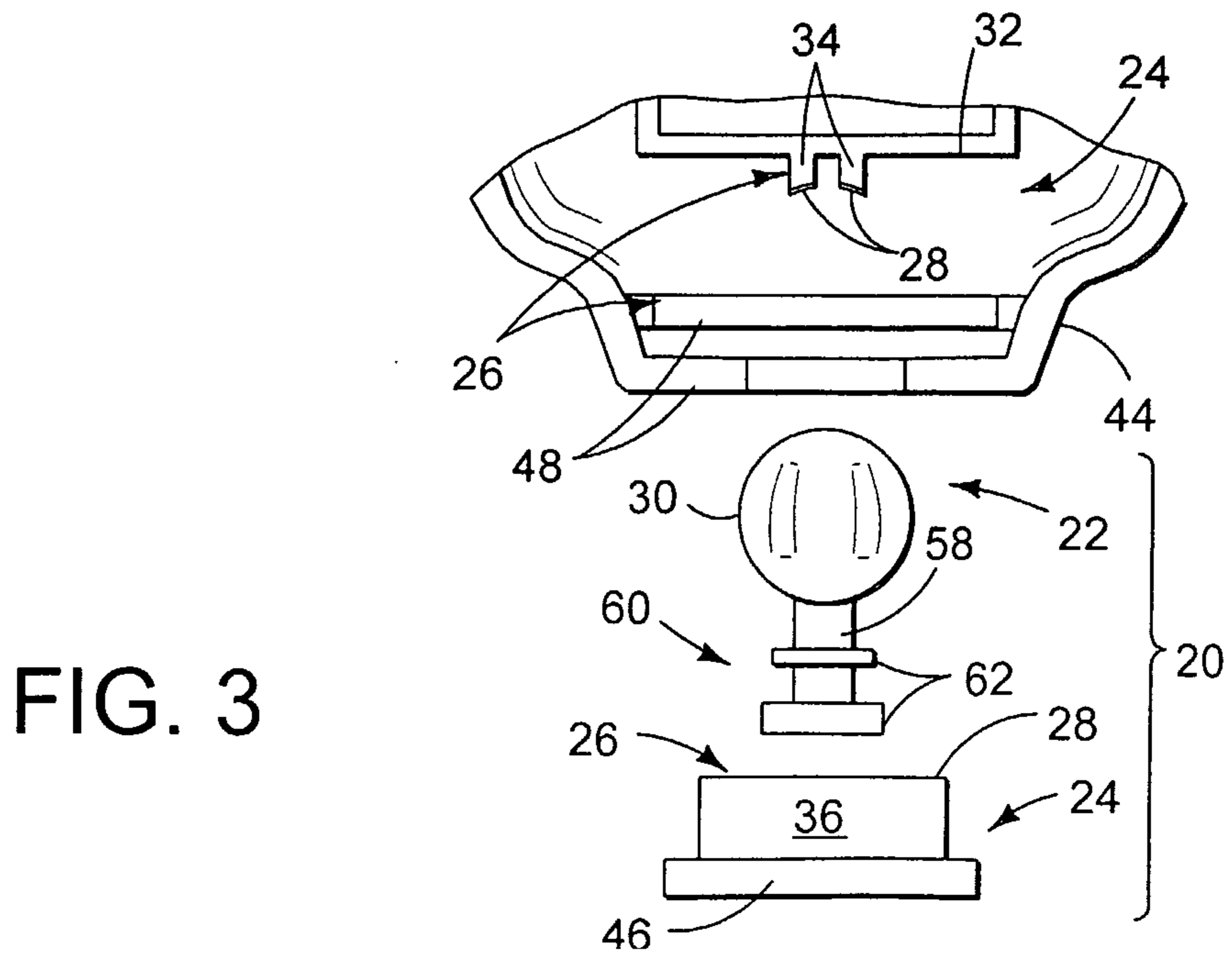
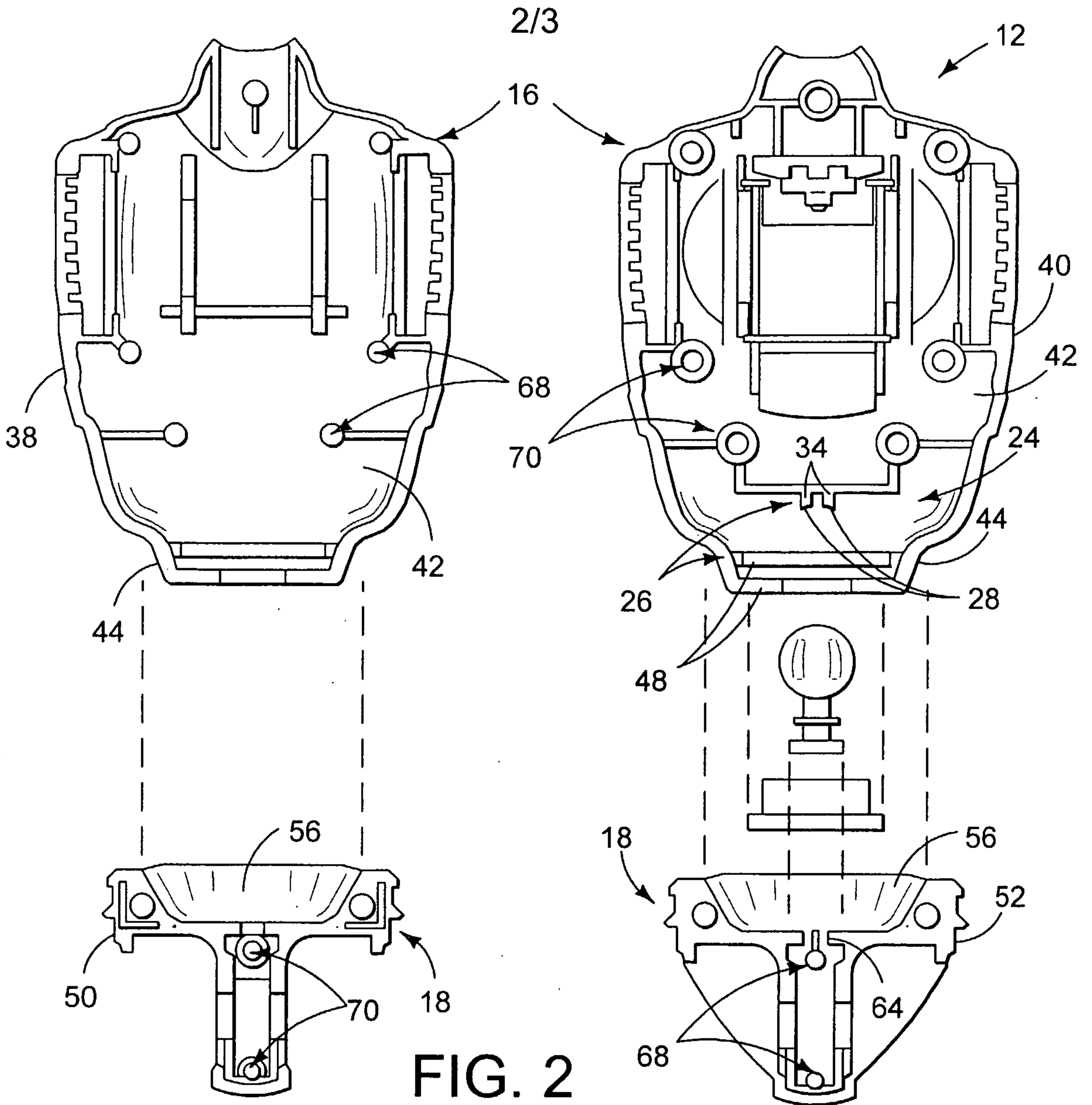

FIG. 1



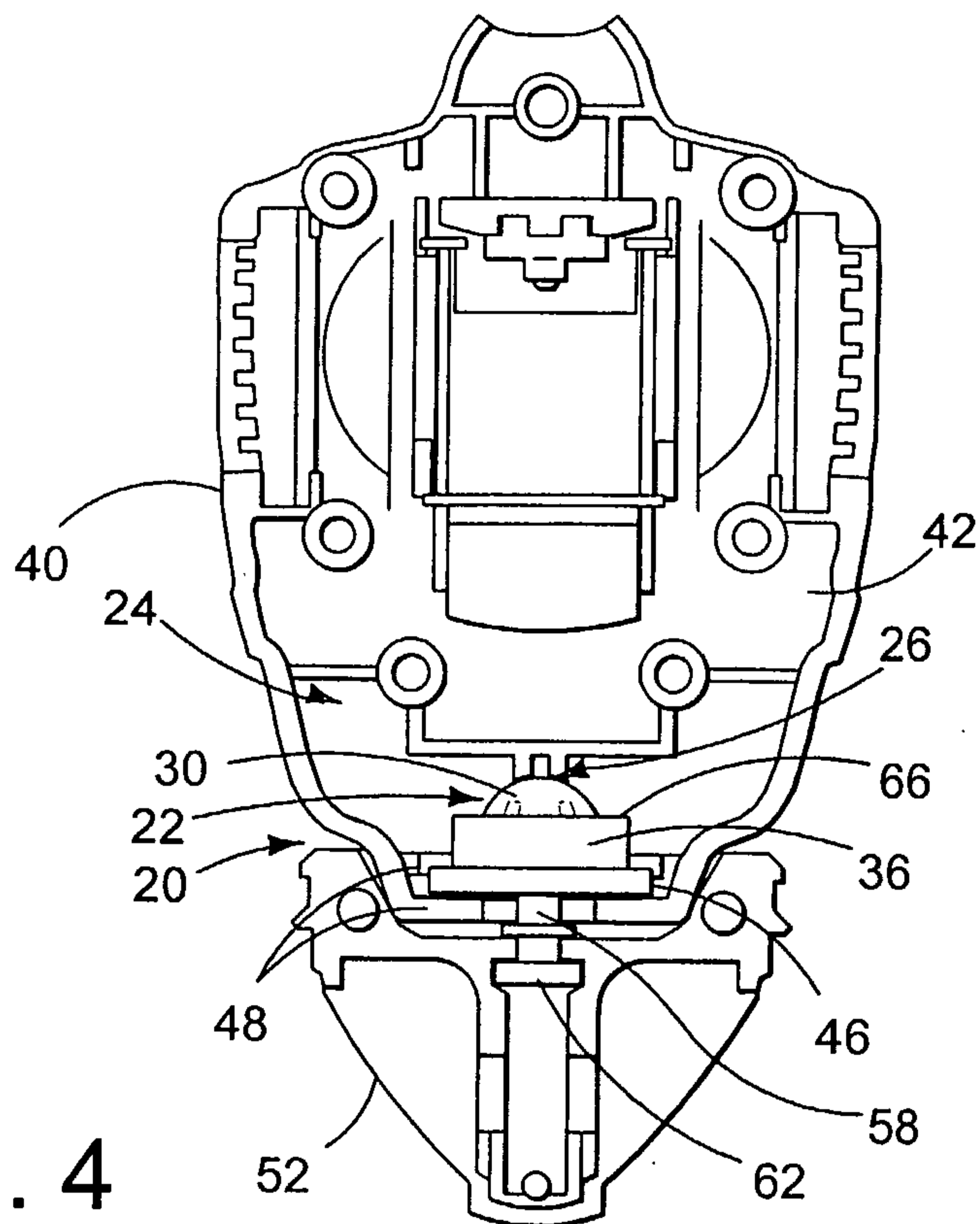

FIG. 4

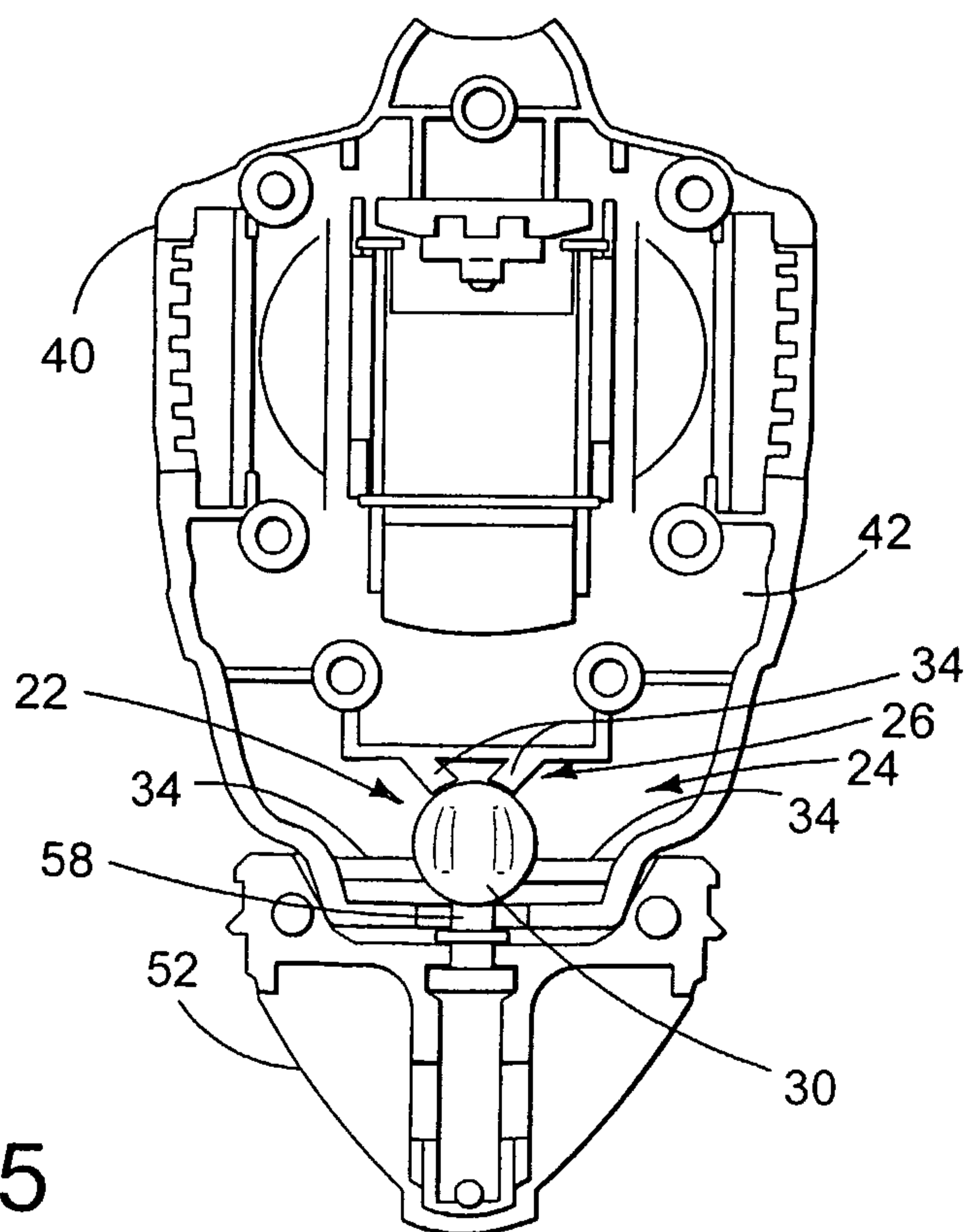

FIG. 5

