

March 13, 1956

A. S. GUIGNARD ET AL

2,738,075

DISPLAY RACK

Filed July 25, 1952

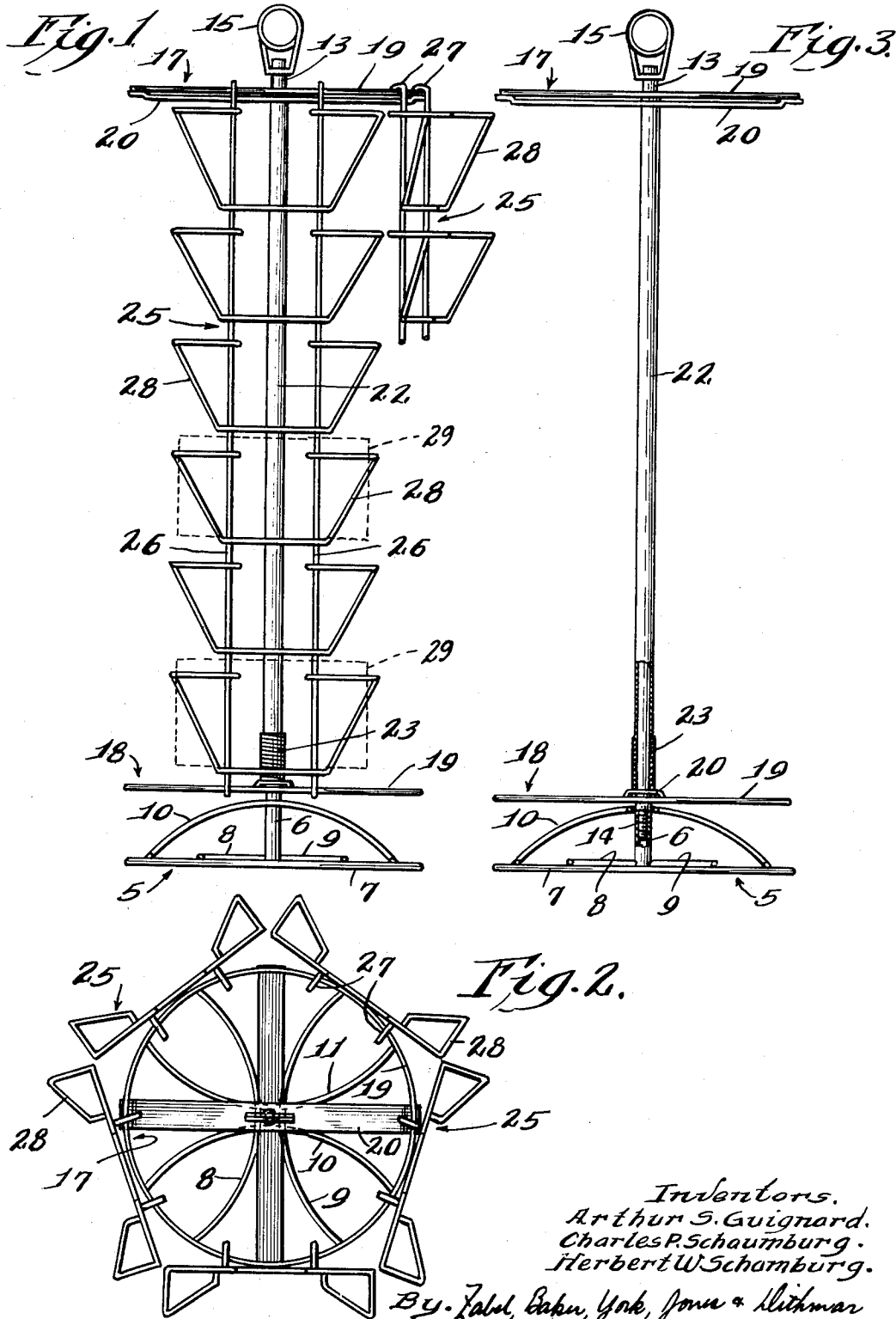

Inventors.  
Arthur S. Guignard.  
Charles P. Schaumburg.  
Herbert W. Schaumburg.  
By: Zabel, Baker, York, Jones & Mithman  
Attorneys.

1

2,738,075

**DISPLAY RACK**

Arthur S. Guignard, Oak Park, Charles P. Schaumburg, Maywood, and Herbert W. Schaumburg, Oak Park, Ill., assignors to The Kerr Wire Products Co., Chicago, Ill., a corporation of Illinois

Application July 25, 1952, Serial No. 300,886

2 Claims. (Cl. 211-56)

Our invention relates to a display rack, and more particularly to a display rack which utilizes readily detachable components. The display rack is suitable for carrying a stock of postcards, greeting cards, bagged or carded merchandise, magazines, pamphlets, books and the like, and for displaying one or more samples of each.

Prior display racks or devices of this character are relatively bulky in size, and, accordingly, they present a substantial shipping or transportation problem when moving from the manufacturer to a dealer and from a dealer to the ultimate customer.

One object of our invention is to provide a display rack comprising a plurality of individual, relatively flat and nestable components which may be shipped or transported in a knocked-down condition. The characteristics of the individual components are such that the components of one display rack of a practical size may be contained in a package which is smaller than the recently prescribed maximum parcel post size, thereby enabling the knocked-down rack to be shipped via parcel post. The invention, however, is not limited by size considerations.

Another object of our invention is to provide individual components which may be easily and quickly assembled into a display rack by the ultimate customer-user.

Another object is to provide a structurally strong and durable display rack which can be manufactured, sold and shipped at extremely low cost.

Other objects, advantages and details of our invention will be apparent as the description proceeds, reference being had to the accompanying drawing wherein one form of the invention is shown. It will be understood that the description and drawing are illustrative only and are not to be taken as limiting the invention except insofar as it is limited in the claims. Further, it will be understood that commercial forms of the display rack might well vary somewhat from that here illustrated and described.

In the drawing:

Fig. 1 is a view in side elevation of a display rack embodying our invention, several of the rack members having been omitted from the figure for clarity;

Fig. 2 is a top view of the display rack wherein all the rack members are shown; and

Fig. 3 is a view in side elevation, partly in section, with all the rack members omitted.

The display rack here illustrated and about to be described has components made for the most part out of bent wire. This is a practical, inexpensive construction but it is to be understood that the invention may be followed with components made of materials other than bent wire.

A display rack embodying our invention and illustrated in the drawing includes a separate base 5. This base 5, adapted to rest on a counter, table, shelf or the like, is of sufficient lateral size to provide requisite stability. An upstanding shaft attaching means such as stud 6 is located centrally of base 5, and, in the form of the inven-

2

tion shown, stud 6 is a tubular member provided with internal threads. Alternatively, external threads could, of course, be used.

As shown, base 5 comprises a circular wire ring 7 reinforced by arcuate wire lengths 8, 9, 10 and 11. The wire lengths 8-11 extend between and are welded or otherwise secured to central stud 6 and the wire ring 7.

An elongated shaft 13, having threads 14 at one end, is adapted to detachably engage threaded stud 6 or other attaching means, as best shown in Fig. 3. A head or handle 15 may be provided at the other end of shaft 13 for convenience in turning shaft 13 when the rack is assembled, and for carrying the assembled rack from one place to another. Head 15 also is adapted to hold an advertising sign or price card.

A pair of spaced terminal members, upper terminal member 17 and lower terminal member 18, are carried on shaft 13. Terminal members 17, 18 may be duplicates, and comprise a wire ring 19 and a diametrically extending strut 20. The latter is welded or otherwise suitably secured at its ends to ring 19, and it is provided with a central opening which passes shaft 13. Upper terminal member 17 is best shown in Fig. 2.

Terminal members 17 and 18, in the form of the invention illustrated, are spaced from each other on shaft 13 by means of an elongated sleeve 22, which fits over the shaft between the terminal members, and a resilient element such as a spiral spring 23. As shown in Fig. 3, lower terminal member 18 rests on the top of stud 6, spring 23 rests on the top of terminal member 18, sleeve 22 rests on the top of spring 23 and upper terminal member 17 rests on the top of sleeve 22. This, of course, is the general sequence followed in assembling our display rack, although the relative positioning of the sleeve 22 and spring 23 is unimportant.

A plurality of rack members 25 extend in circumferentially spaced relation between upper and lower terminal members 17 and 18, as shown in Fig. 1. In the form of the invention shown, each rack member 25 is a more or less non-rigid ladder-like structure comprising two spaced wires or rods 26 which extend between upper and lower terminal members 17 and 18. Rods 26 are provided at their ends with means for attachment to the terminal members, and, as illustrated, the wire ends are simply bent to provide hooks 27. Vertically spaced merchandise holding receptacles 28, again made of bent wire, are suitably attached as by welding to the rods 26. The merchandise holding receptacles 28 are preferably designed so that the rack members 25 will nest with each other when the rack is in disassembled condition for shipping. Merchandise 29 is shown in dotted outline in Fig. 1.

The length of rods 26 is such that the resilient member or spring 23 on shaft 13 is stressed in compression when the rack members are mounted on the terminal members 17 and 18. The stressed spring 23 imparts stability to the assembly, and yet enables the rack members 25 and the associated terminal members 17 and 18 to freely rotate on shaft 13.

From the above description it is thought that the construction and advantages of our invention will be readily apparent to those skilled in the art. Various changes in detail may be made without departing from the spirit or losing the advantages of the invention.

Having thus described our invention, what we claim as new and desire to secure by Letters Patents is:

1. A display rack comprising a base, an upstanding elongated shaft detachably mounted on said base, a pair of spaced terminal members having central openings therein with said shaft passing through said openings, an elongated sleeve and a resilient element on said shaft between said terminal members, and a plurality of spaced rack members each extending continuously between said

3

terminal members, said rack members being non-rigid in character, the ends of said rack members having means for detachably engaging said terminal members, the length of said rack members being such as to stress said resilient element in compression.

2. A display rack according to claim 1 wherein each rack member comprises a pair of spaced parallel rods, the ends of said rods being bent to provide hooks, and a plurality of spaced holders carried by said rods.

4

## References Cited in the file of this patent

## UNITED STATES PATENTS

283,994	French	Aug. 28, 1883
929,714	Schlegel	Aug. 3, 1909
1,235,225	Miller	July 31, 1917
2,497,760	Chambers	Feb. 14, 1950
2,608,420	Eck	Aug. 26, 1952

5