



US00D683868S

(12) **United States Design Patent**  
**Blasi**

(10) **Patent No.:** **US D683,868 S**

(45) **Date of Patent:** **\*\* Jun. 4, 2013**

(54) **HEADLIGHT FOR A VEHICLE**

*Primary Examiner* — Marcus Jackson

(75) Inventor: **Juliane Blasi**, Munich (DE)

(74) *Attorney, Agent, or Firm* — Crowell & Moring LLP

(73) Assignee: **Bayerische Motoren Werke Aktiengesellschaft**, Munich (DE)

(57) **CLAIM**

The ornamental design for a headlight for a vehicle, as shown and described.

(\*\*) Term: **14 Years**

(21) Appl. No.: **29/398,935**

(22) Filed: **Aug. 8, 2011**

(30) **Foreign Application Priority Data**

Feb. 9, 2011 (DE) ..... 402011000781

(51) **LOC (9) Cl.** ..... **26-06**

(52) **U.S. Cl.**

USPC ..... **D26/28**

(58) **Field of Classification Search**

USPC ..... D26/28–36; 362/459–468, 475–478,  
362/485–487

See application file for complete search history.

(56) **References Cited**

**U.S. PATENT DOCUMENTS**

D538,956 S *	3/2007	Ishii	.....	D26/28
D561,358 S *	2/2008	Tachibana	.....	D26/28
D570,007 S *	5/2008	Hsu	.....	D26/28
D582,587 S *	12/2008	Yang	.....	D26/28
D593,232 S *	5/2009	Koman et al.	.....	D26/28
D635,694 S *	4/2011	Yang et al.	.....	D26/28

\* cited by examiner

**DESCRIPTION**

This application contains subject matter related to the following co-pending U.S. design patent application:

Application Ser. No. 29/398,932, filed herewith and entitled "Vehicle, Toy, and/or Replicas Thereof".

FIG. 1 is a right, front perspective view of a first embodiment of a headlight for a vehicle according to my design;

FIG. 2 is a left, front perspective view thereof;

FIG. 3 is a front view thereof;

FIG. 4 is a right side view thereof;

FIG. 5 is a left side view thereof;

FIG. 6 is a top view thereof; and

FIG. 7 is a bottom view thereof.

FIG. 8 is a left front perspective view of the second embodiment of the headlight for a vehicle showing of our new design, with the headlight for a vehicle for the opposite side of the vehicle being depicted in the first embodiment;

FIG. 9 is a right, front perspective view thereof;

FIG. 10 is a front view thereof;

FIG. 11 is a left side view thereof;

FIG. 12 is a right side view thereof;

FIG. 13 is a top view thereof; and,

FIG. 14 is a bottom view thereof.

**1 Claim, 10 Drawing Sheets**

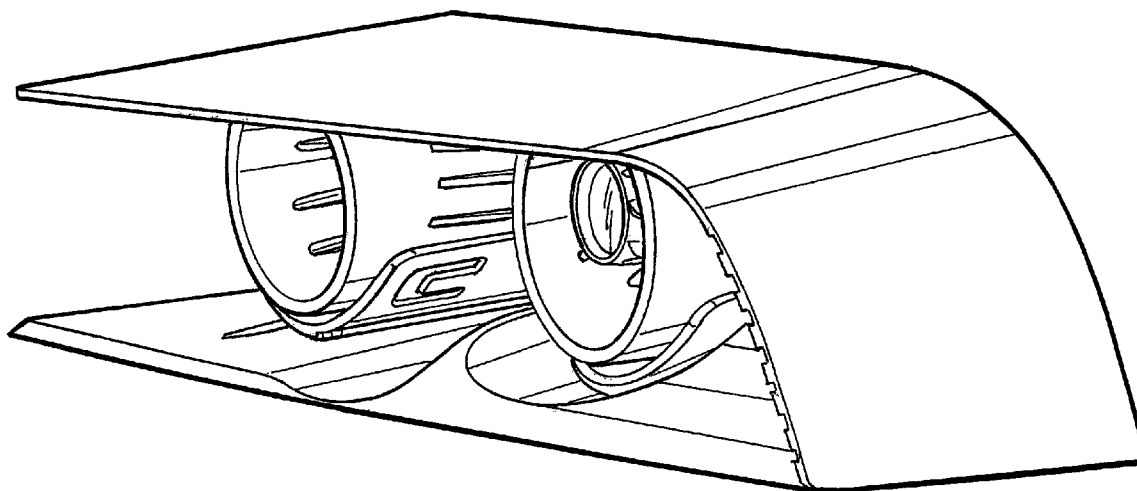

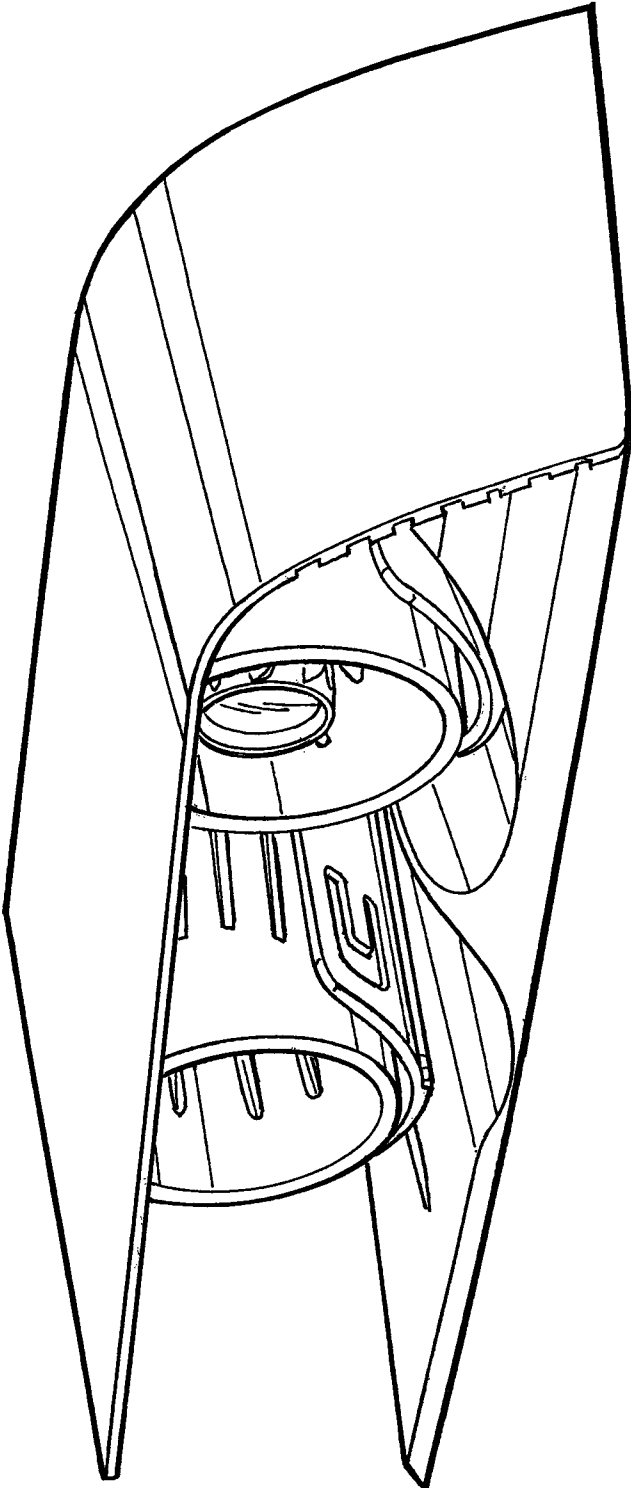

FIG. 1

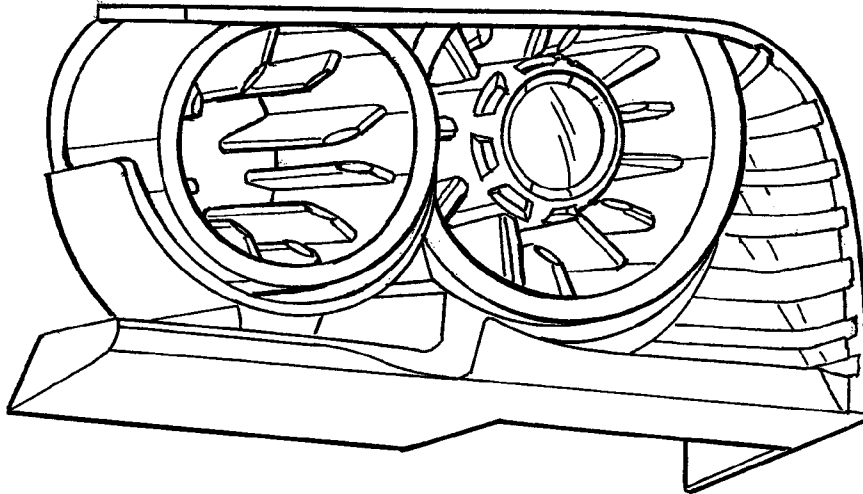

FIG. 2

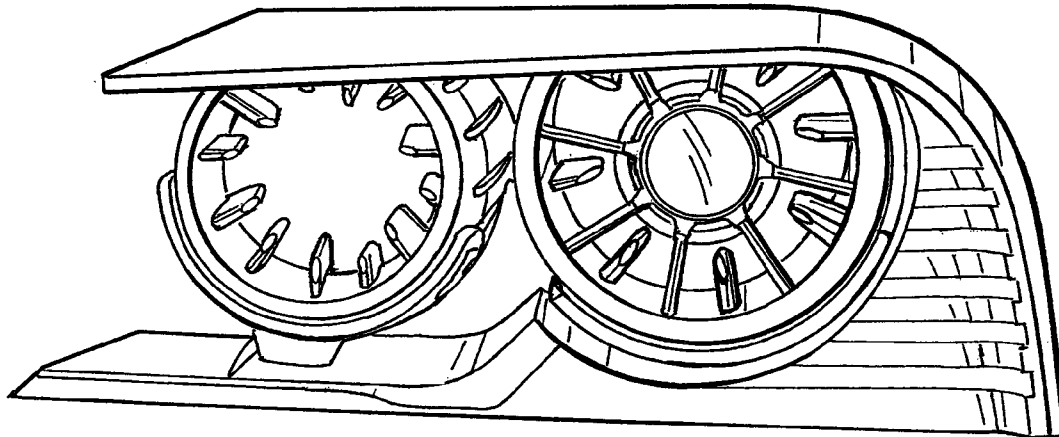

FIG. 3

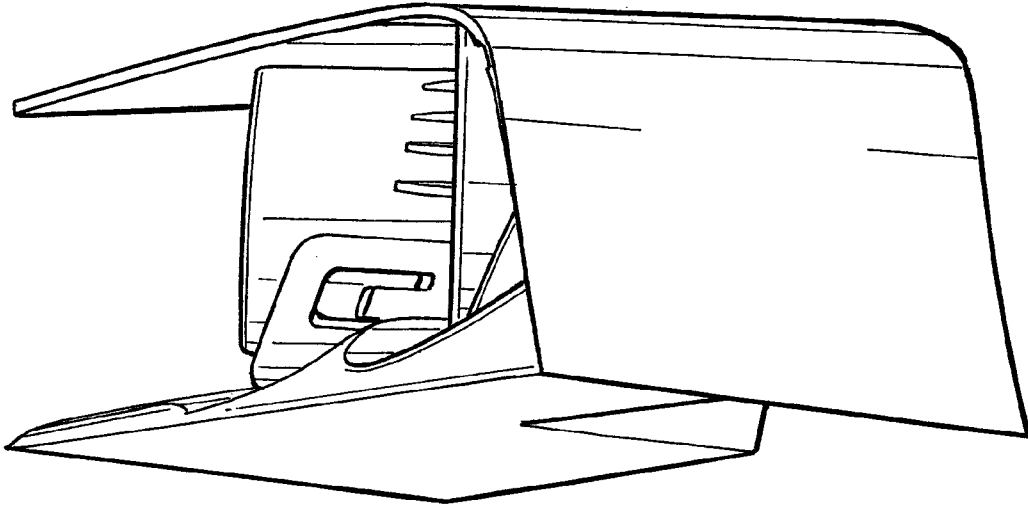

FIG. 4

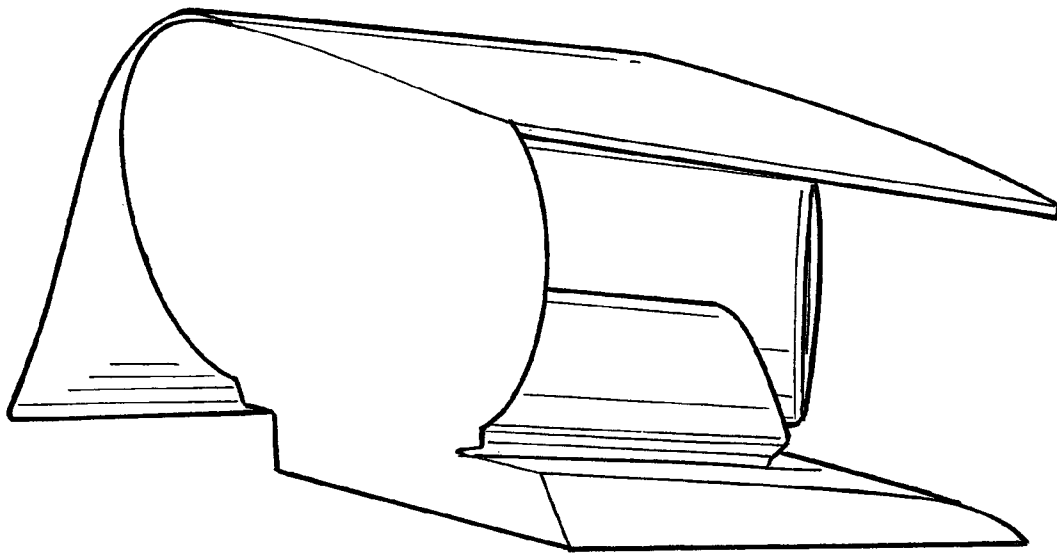

FIG. 5

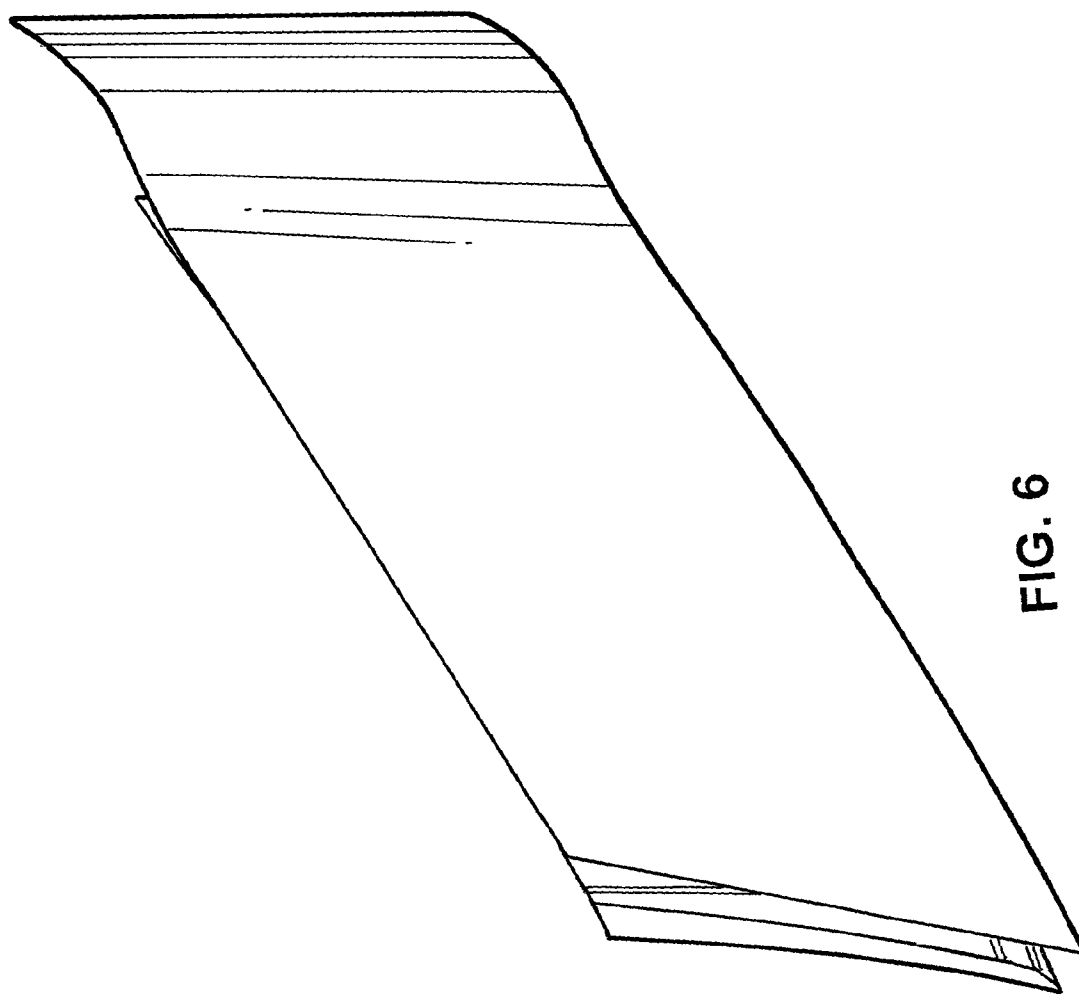

FIG. 6

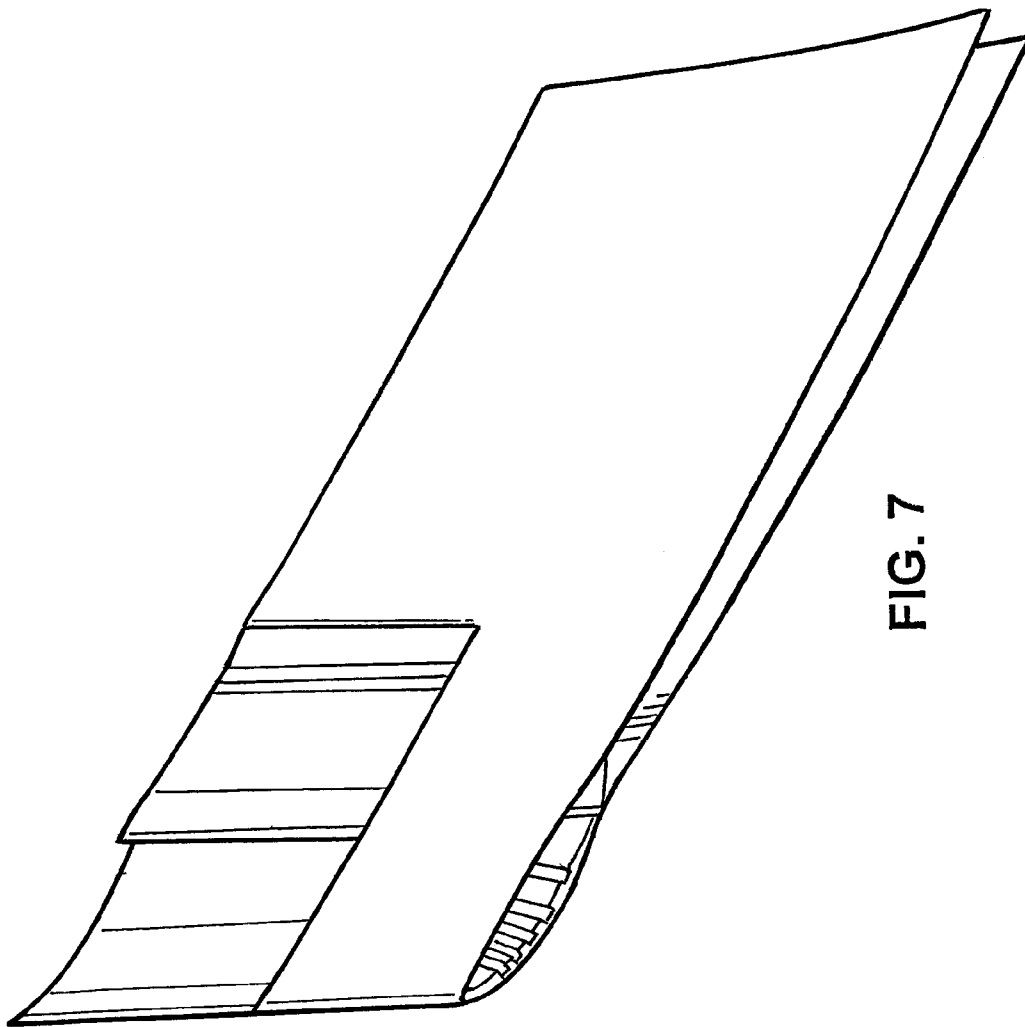

FIG. 7

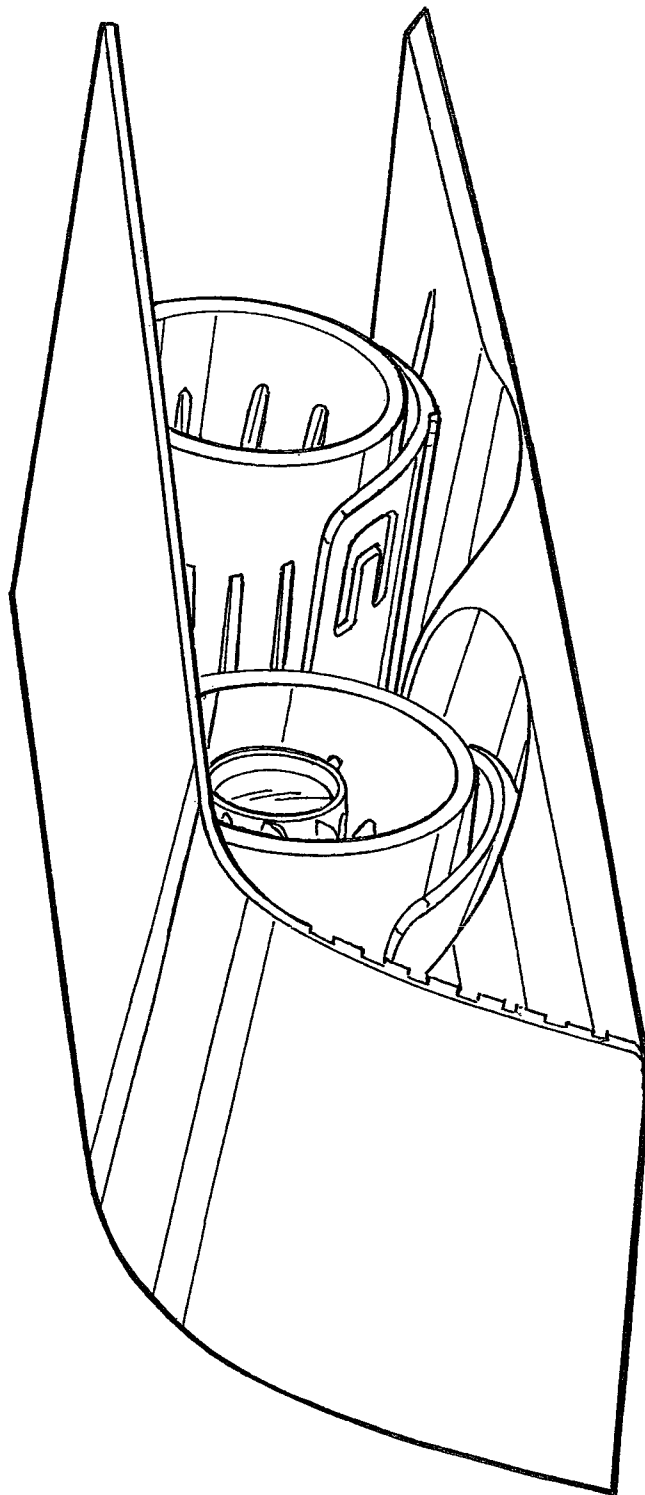

FIG. 8

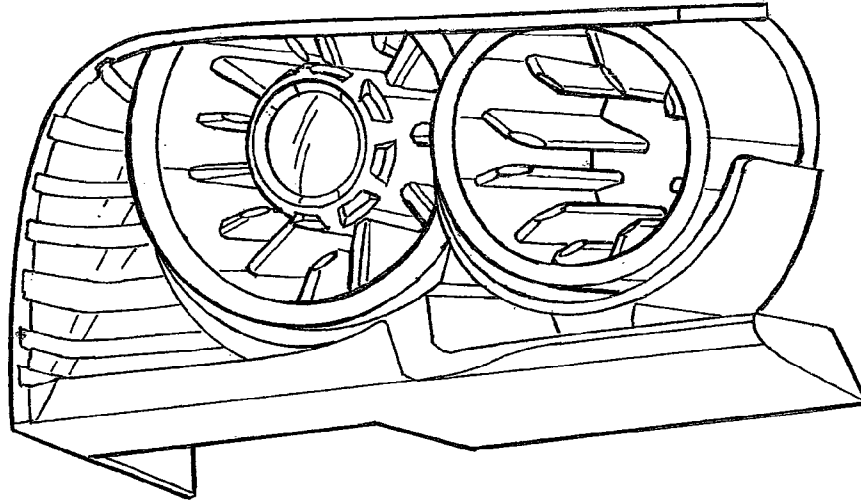

FIG. 9

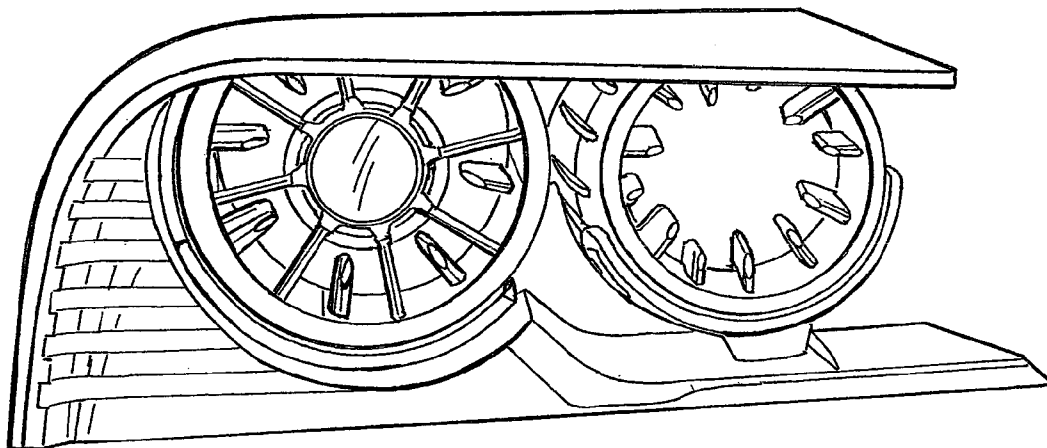

FIG. 10



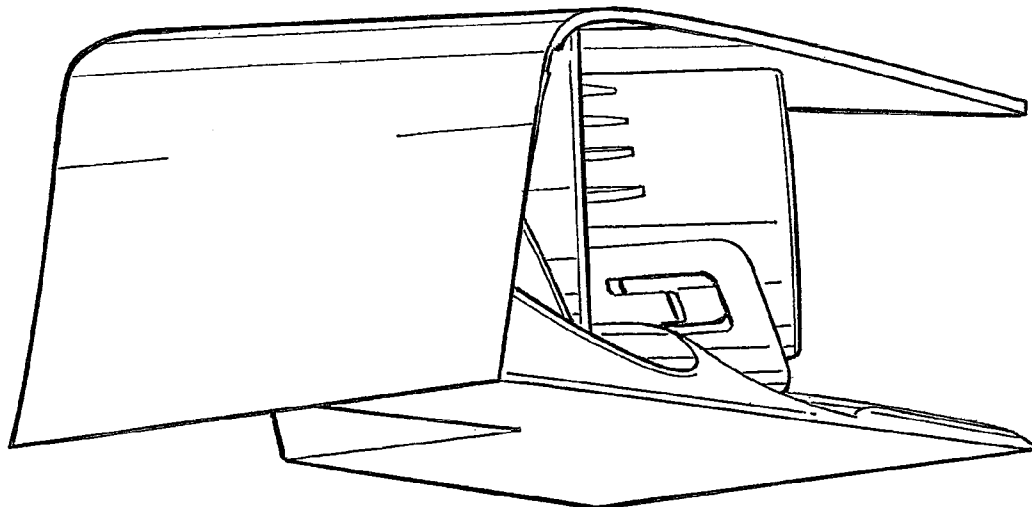

FIG. 11

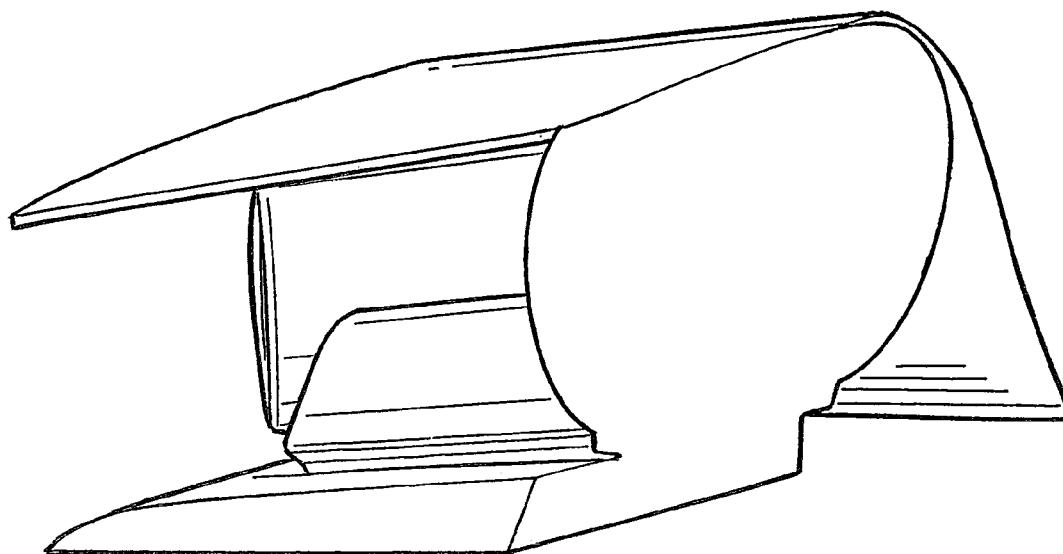

FIG. 12

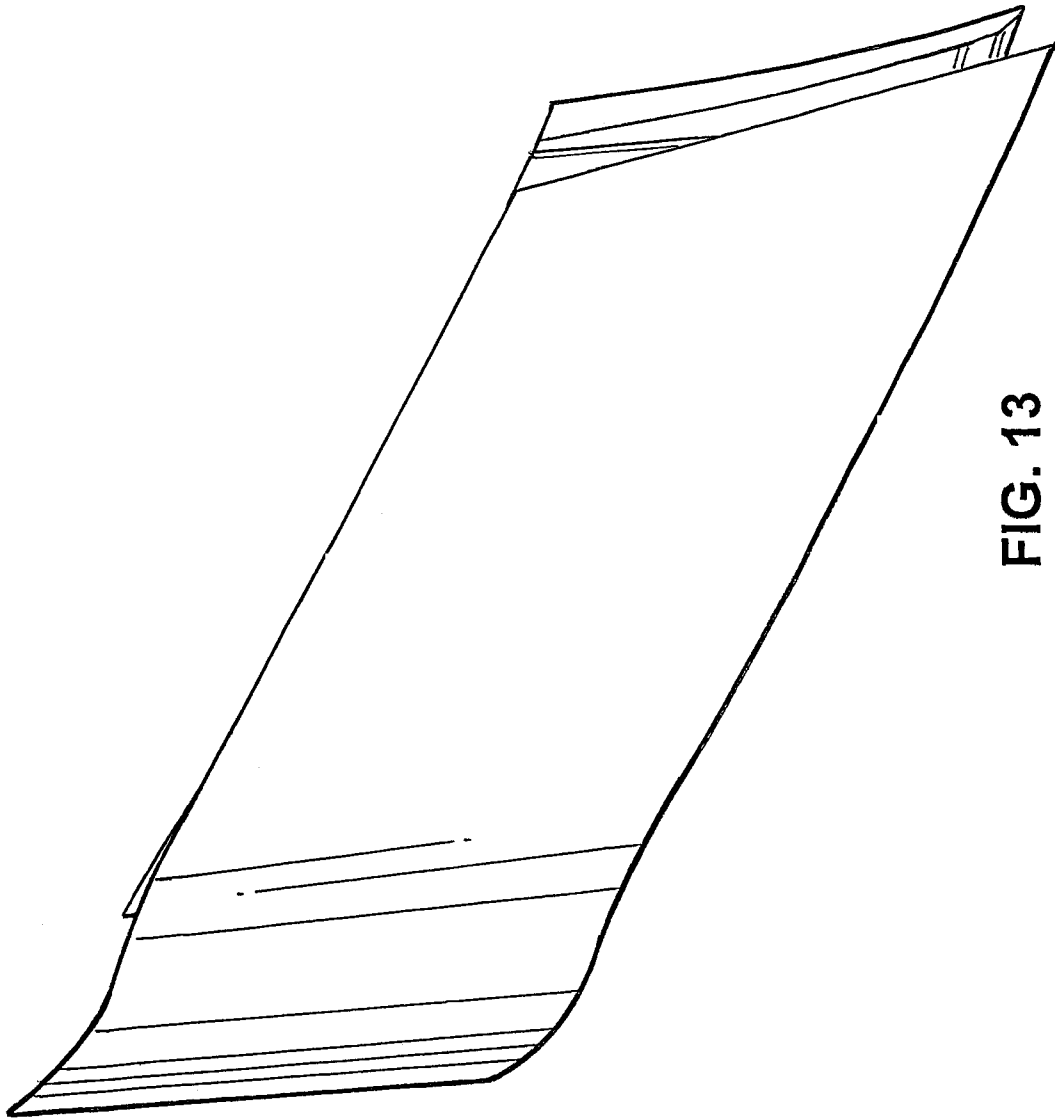

FIG. 13

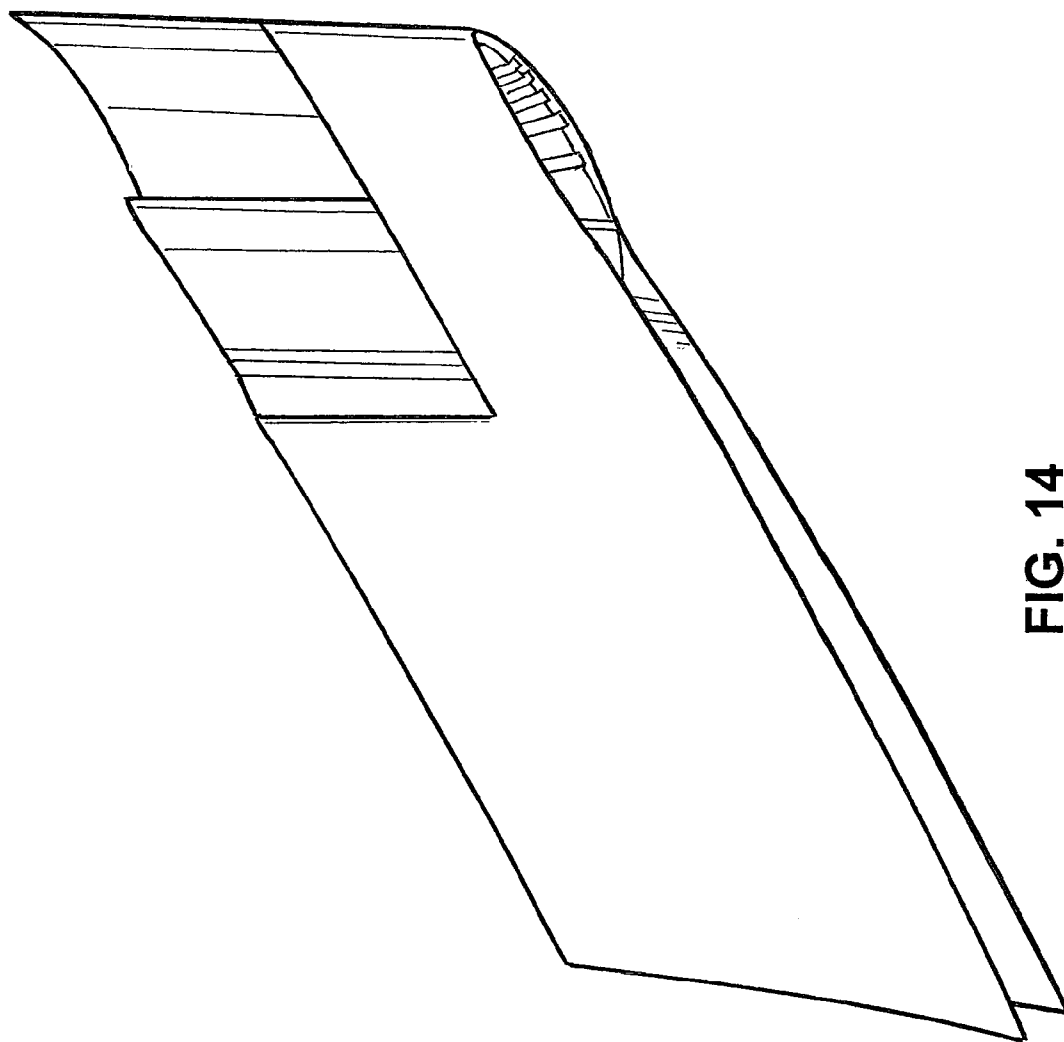

FIG. 14