

[54] BOLT LATCH FOR AUTO LOADING FIREARM

[75] Inventors: William B. Ruger, Southport; Harry H. Sefried II (New Haven, both of Conn.

[73] Assignee: Strum, Ruger & Co., Inc., Southport, Conn.

[22] Filed: Aug. 20, 1973

[21] Appl. No.: 389,710

[52] U.S. Cl. 42/16, 89/138

[51] Int. Cl. F41c 11/00, F41d 1/00

[58] Field of Search 42/16; 89/138

[56] References Cited

UNITED STATES PATENTS

981,210	1/1911	Menteyne et al.	89/138
1,533,966	4/1925	Browning	89/138
2,325,395	7/1943	Hammond	89/138
2,548,622	4/1951	Sampson et al.	89/138
2,571,132	10/1951	Harvey	89/138

Primary Examiner—Benjamin A. Borchelt
Assistant Examiner—C. T. Jordan
Attorney, Agent, or Firm—Pennie & Edmonds

[57] ABSTRACT

An auto-loading firearm having a bolt that moves rear-

wardly from its forward closed position to its rearward open position and then forwardly to its closed position when the firearm is fired is provided with means for holding the bolt at its open position when the magazine is empty and the last cartridge has been fired. The bolt lock means comprises a bolt lock lever pivotally mounted on the side of the receiver, said bolt lock lever having a magazine follower engaging arm at the forward end thereof and a bolt stop arm at the rearward end thereof, said forward and rearward ends of the bolt lock lever being vertically movable between upper and lower positions when the bolt latch lever is rotated about the pivot thereof. A bolt stop lug is disposed at the rearward end of the bolt in position to be clear of the bolt stop arm when the rearward end of the bolt lock lever is at its upper position and in position to be blocked by the bolt stop arm when the rearward end of the bolt lock lever is at its lower position. A bolt lock activating surface is disposed on the upper end of the spring-pressed magazine follower of the magazine in position to contact the magazine follower engaging arm of the bolt lock lever, said bolt lock lever activating surface moving the forward end of the pivoted bolt lock lever to its upper position and moving the rearward end of the pivoted bolt lock lever to its lower position when the magazine is empty.

6 Claims, 11 Drawing Figures

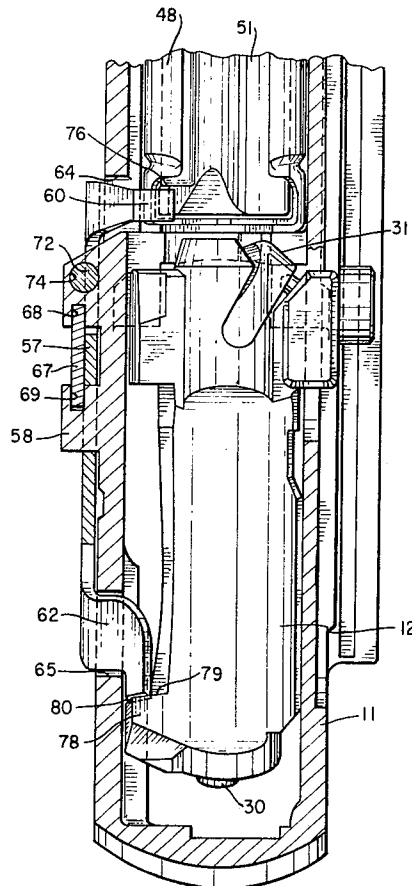

FIG. 1

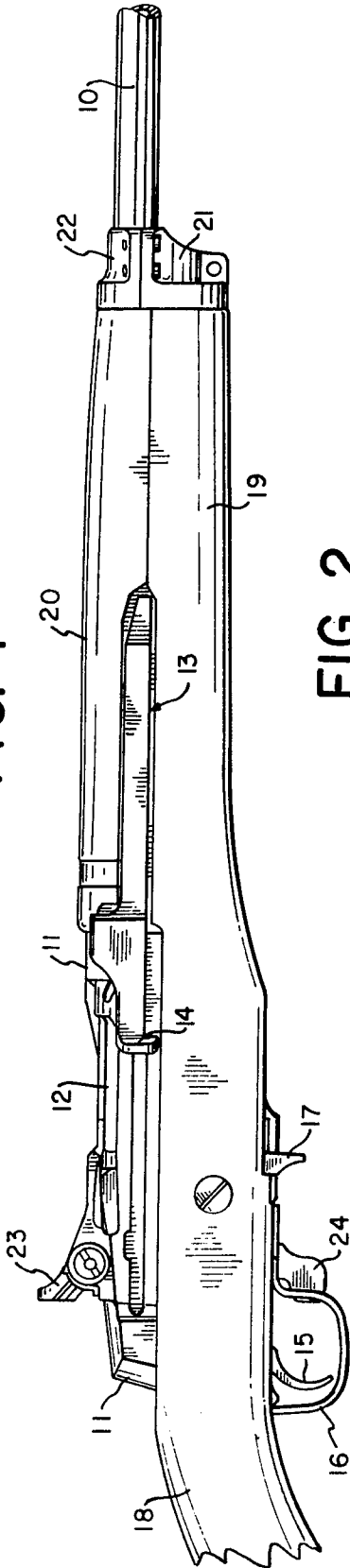

FIG. 2

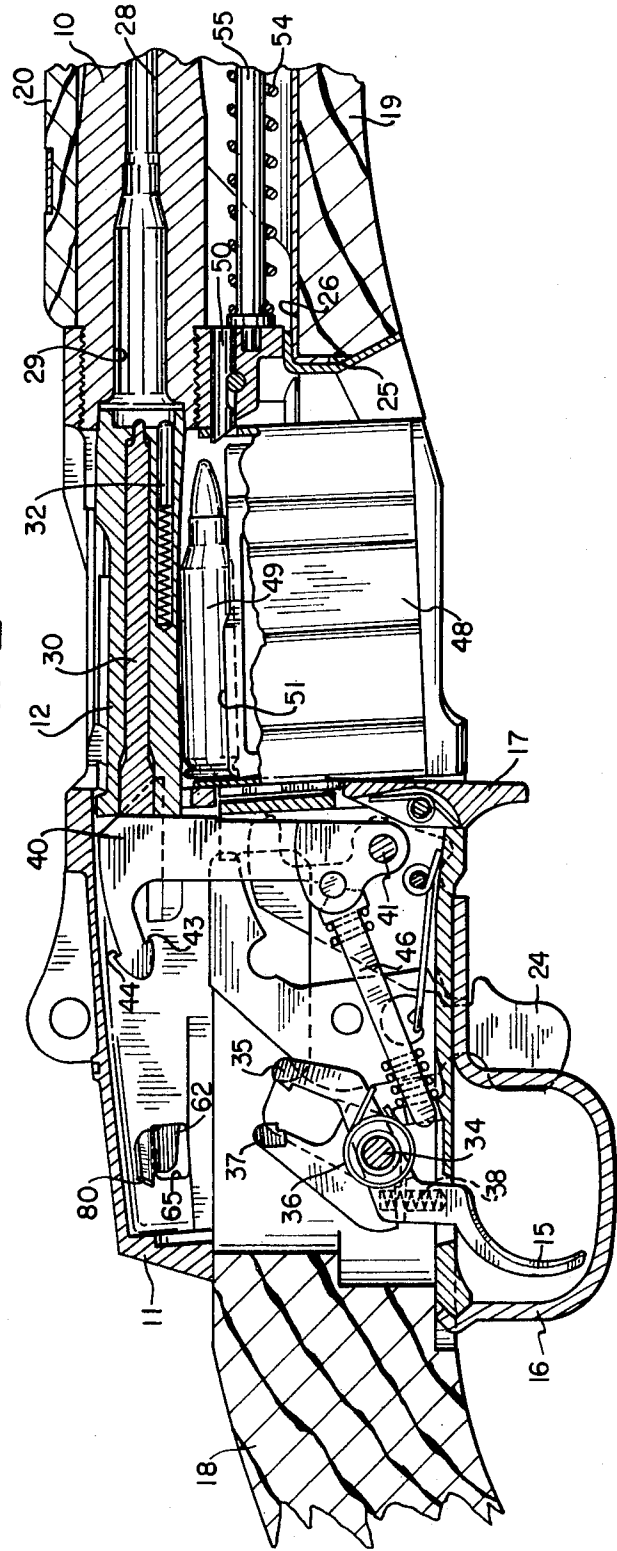

FIG. 3

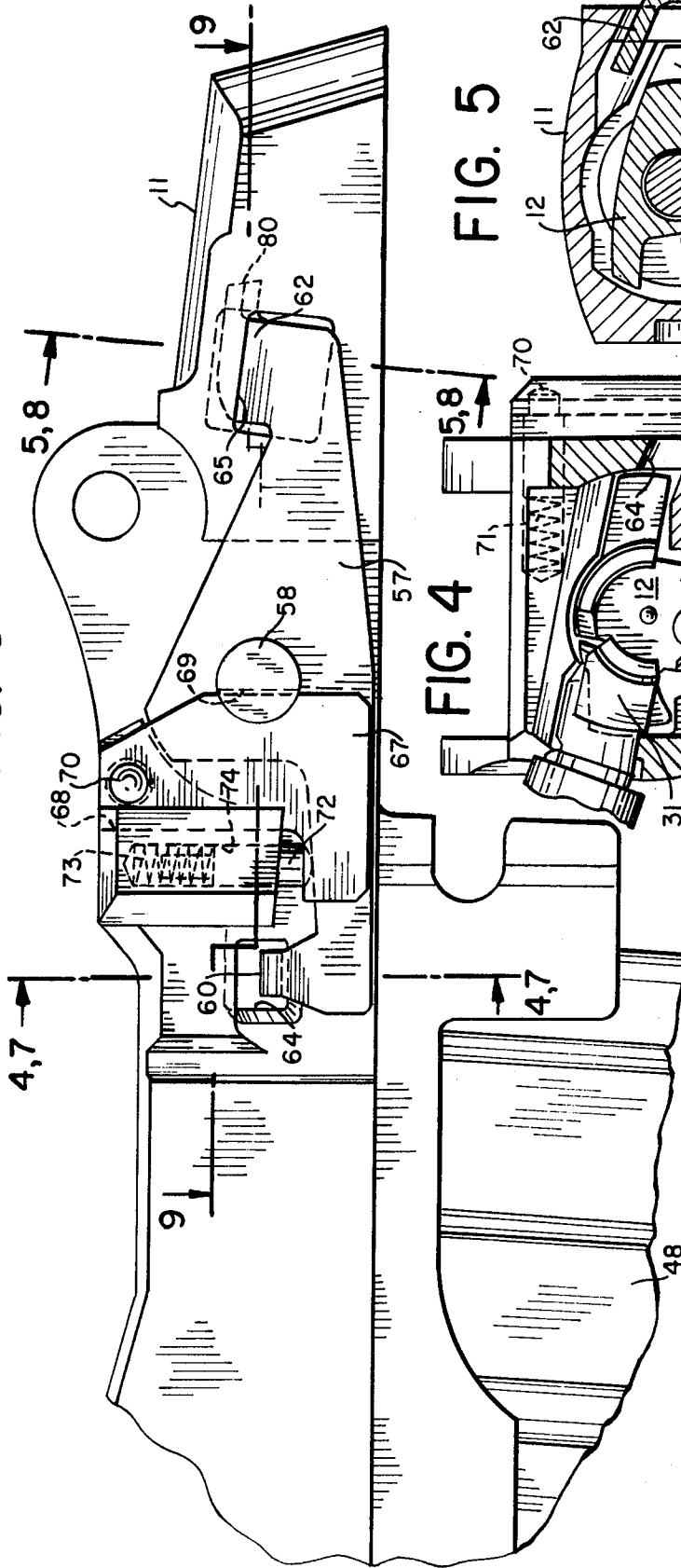

FIG. 5

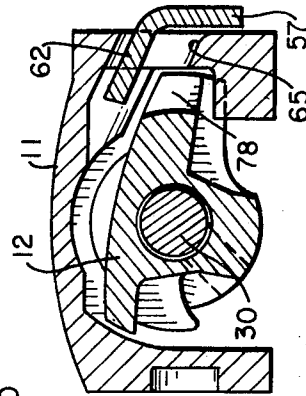

FIG. 4

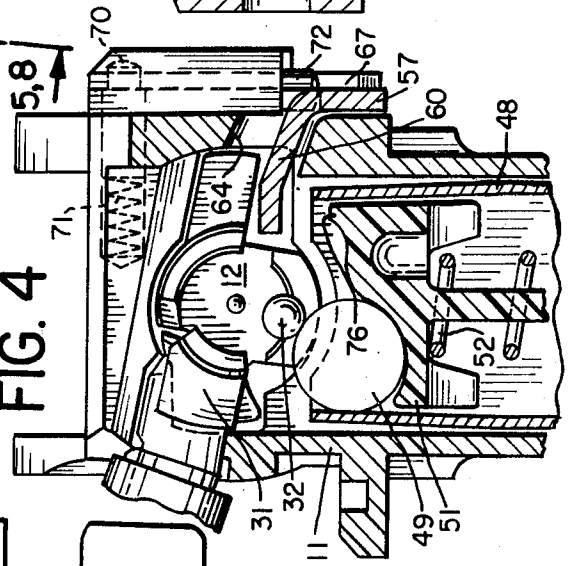

FIG. 6

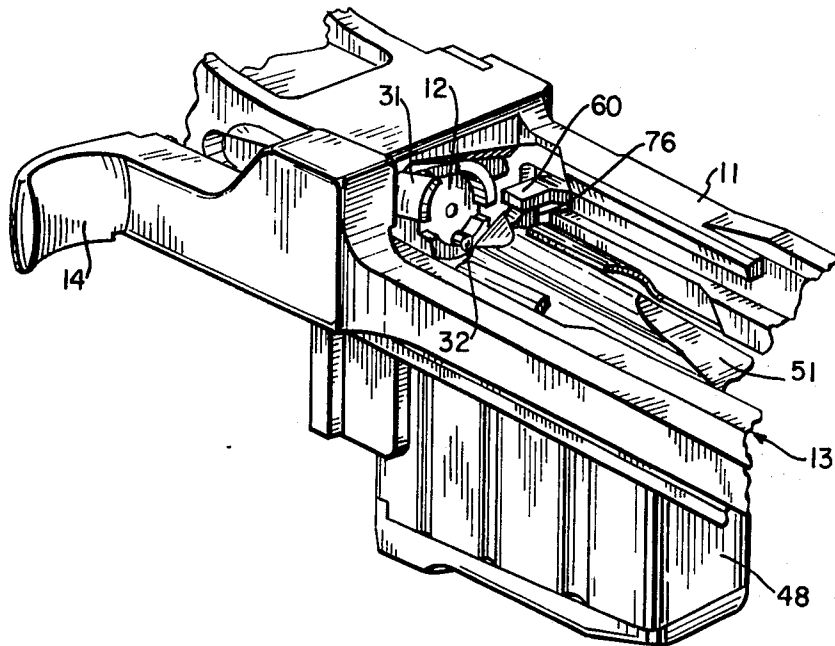

FIG. 7

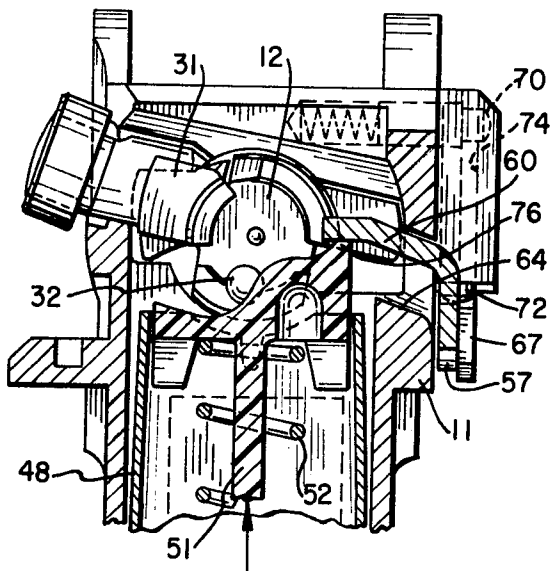

FIG. 8

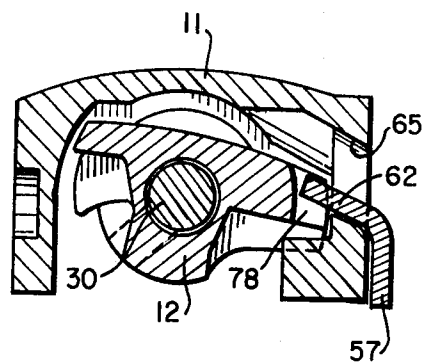

FIG. 9

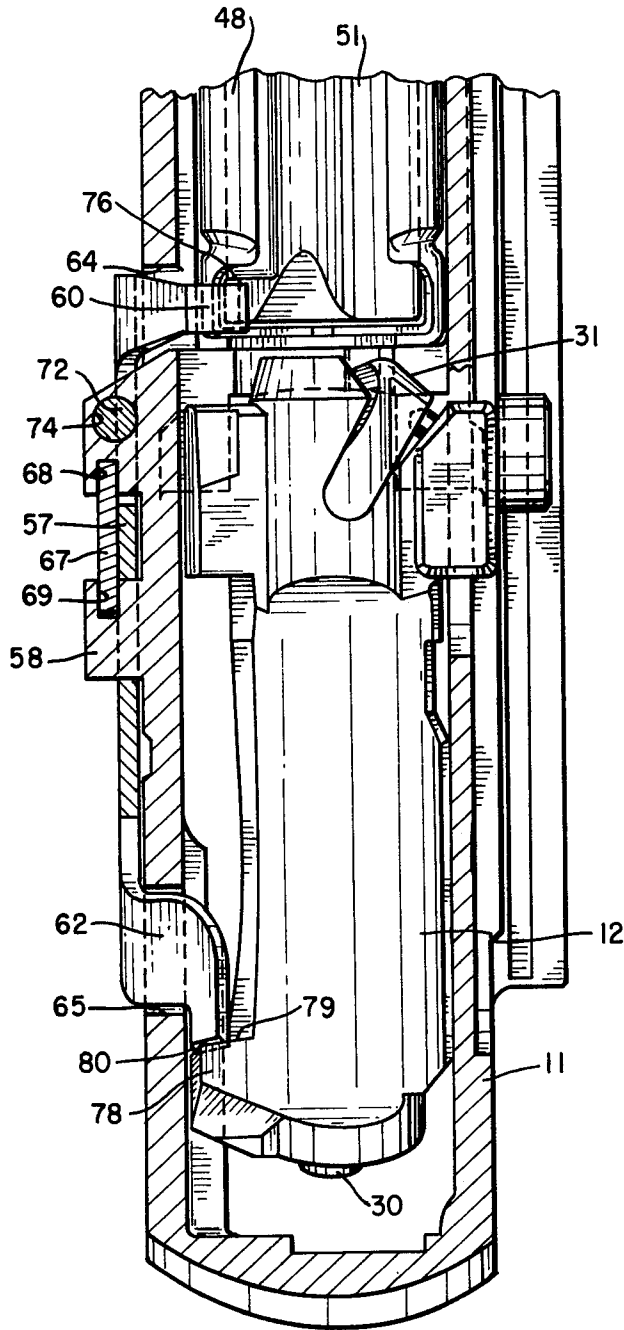

FIG. 10

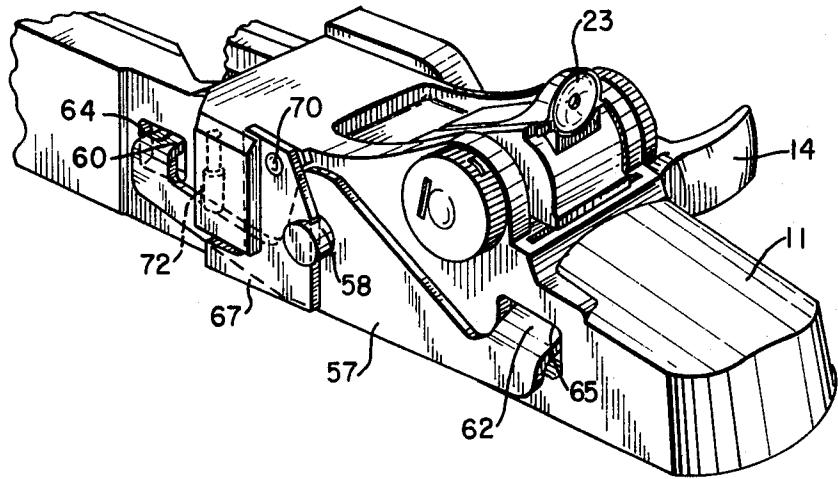
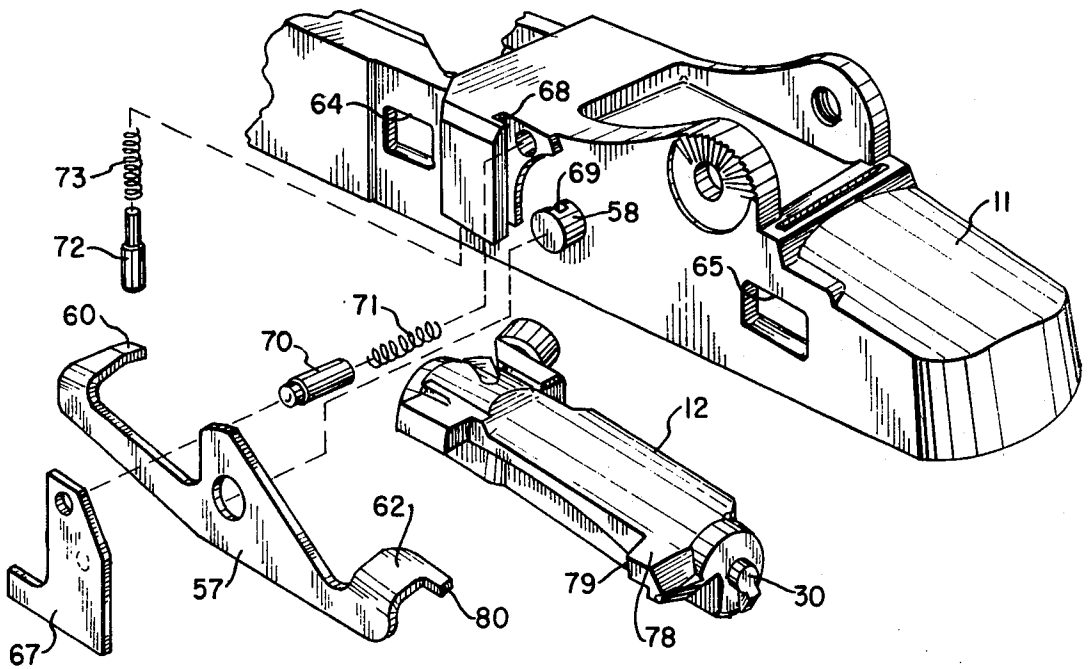

FIG. 11



BOLT LATCH FOR AUTO LOADING FIREARM**BACKGROUND OF THE INVENTION****1. Field of the Invention**

This invention relates to auto-loading firearms, and in particular to gas-operated auto-loading rifles.

2. Prior Art

Auto-loading firearms of the type to which the present invention relates have a receiver, a barrel mounted on the forward end of the receiver, a bolt slidably mounted for longitudinal travel in the receiver behind the barrel, an auto-loading mechanism (usually, gas-operated) connected to the bolt for moving the bolt from its forward closed position to its rearward open position and return when the firearm is fired, a trigger and related parts of the firing mechanism, and a cartridge magazine disposed in the receiver beneath the bolt. When the firearm is fired, the bolt is caused by the auto-loading mechanism to travel from its closed position to its open position and to return to its closed position, the bolt extracting and ejecting the spent cartridge case as it travels rearwardly to its open position and then picking up a fresh cartridge from the magazine and inserting the cartridge in the chamber of the barrel as it returns to its closed position.

Typically, the magazine comprises a box-like structure that is adapted to contain a plurality of cartridges and to feed the cartridges to the loading mechanism of the firearm. The magazine is provided with a vertically movable spring-pressed magazine follower that moves the cartridges upwardly toward the open upper end of the magazine where the cartridges are loaded, one at a time, into the barrel of the firearm. As noted, the bolt moves from its normally closed position to its open position and then back to its closed position each time the firearm is fired. After the last cartridge from the magazine has been fired and extracted and the magazine is empty, the bolt would normally return to its closed position unless means are provided to automatically lock the bolt in its open position when the magazine is empty. When the bolt is automatically locked in its open position, the shooter is made aware of the fact that the magazine is empty and reloading of the empty magazine is greatly facilitated.

Various mechanisms have heretofore been proposed for locking the bolt in its open position when the magazine is empty and the last cartridge therefrom has been fired, extracted and ejected. Many of these mechanisms are unduly complicated or are unreliable or subject to structural failure. After an intensive investigation of the limitations and problems associated with the design of a satisfactory bolt lock arrangement for semi-automatic firearms, we have now devised a new bolt lock for such firearms which is sturdy, reliable and simple in operation.

SUMMARY OF THE INVENTION

As previously mentioned, firearms to which the present invention relates have a receiver, a barrel, a bolt mounted in the receiver behind the barrel, an auto-loading mechanism connected to the bolt for moving the bolt from its forward closed position to its rearward open position and return when the firearm is fired, a cartridge magazine disposed beneath the bolt and bolt lock means for locking the bolt in its open position when the magazine is empty and the last cartridge from

the magazine has been fired. The magazine is adapted to contain a plurality of cartridges and has a spring-pressed vertically movable magazine follower that moves the cartridges contained in the magazine upwardly into position to be loaded into the chamber of the barrel.

The improved bolt lock means of the invention comprises a longitudinally disposed bolt lock lever pivotally mounted on the side of the receiver, the bolt lock lever having a magazine follower engaging arm at the forward end thereof and a bolt stop arm at the rearward end thereof. The forward and rearward ends of the bolt lock lever are each movable vertically between predetermined upper and lower positions when the bolt lock lever is rotated about the pivot thereof. A bolt lock lever spring urges the forward end of the pivoted bolt lock lever to its lower position and the rearward end of said bolt lock lever to its upper position. A bolt stop lug is disposed at the rearward end of the bolt in position to be clear of the bolt stop arm of the bolt lock lever when the rearward end of the lever is at its upper position and in position to be blocked by the bolt stop arm of the bolt lock lever when the rearward end of the lever is at its lower position. A bolt lock activating surface is disposed on the upper end of the spring-pressed magazine follower in position to contact the magazine follower engaging arm of the bolt lock lever when the magazine is empty, said bolt lock activating surface moving the forward end of the pivoted bolt lock lever to its upper position and moving the rearward end of the lever to its lower position when the magazine is empty.

BRIEF DESCRIPTION OF THE DRAWINGS

The bolt lock arrangement for semi-automatic firearms of the invention will be better understood from the following description thereof in conjunction with the accompanying drawings of which:

FIG. 1 is a fragmentary side elevation of an auto-loading rifle embodying the invention,

FIG. 2 is a sectional view along the vertical plane intersecting the longitudinal center line of the receiver portion and the adjacent stock and forearm portions of the rifle of FIG. 1,

FIG. 3 is a fragmentary side elevation of the left side of the rifle of FIG. 1 showing the bolt lock lever in its unlocked position,

FIG. 4 is a sectional view along line 4,7 — 4,7 of FIG. 3 showing the bolt in its rearward position and the bolt lock lever in its unlocked position,

FIG. 5 is a sectional view along line 5,8 — 5,8 of FIG. 3 showing the bolt in its rearward position and the bolt lock lever in its unlocked position,

FIG. 6 is a fragmentary perspective view showing the bolt in its rearward position and the bolt lock lever in its bolt locked position,

FIG. 7 is a sectional view along line 4,7 — 4,7 of FIG. 3 showing the bolt lock lever in its bolt lock position,

FIG. 8 is a sectional view along line 5,8 — 5,8 of FIG. 3 showing the bolt lock lever in its bolt lock position,

FIG. 9 is a sectional view along line 9 — 9 of FIG. 3 showing the bolt in rearward position and the bolt lock lever in the bolt locked position,

FIG. 10 is a perspective view showing the bolt lock assembly mounted on the side of the receiver, and

FIG. 11 is an exploded perspective view corresponding to FIG. 10.

DETAILED DESCRIPTION

As shown best in FIG. 1, the principal externally visible components of a typical gas-operated auto-loading rifle of the type to which the present invention relates include a barrel 10, a receiver 11 to which the barrel is secured, a longitudinally movable bolt 12 mounted in the receiver 11 behind the barrel 10, a longitudinally movable slide 13 having a slide cocking handle 14 that is connected to the bolt 12, a trigger 15 and trigger guard 16, a magazine latch 17, a stock 18 having a stock forearm 19, a forearm upperhand guard 20, a gas block 21 having a block clamp portion 22, a rear sight 23, and a safety activating lever 24. As shown in FIG. 2, the stock 18 is formed with a vertical slot or cut-out portion 25 in which the firing mechanism associated with the trigger 16 and the magazine associated with the magazine latch 17 are received, and the stock forearm 19 is formed with a channel-shaped recess 26 in which the forward end of the slide 13 and the parts associated therewith are received.

Referring again to FIG. 2, the barrel 10 is formed with a bore 28 having a cartridge chamber 29 at the rearward end thereof. The longitudinally movable bolt 12 is provided with a firing pin 30 in position to strike a cartridge received in the chamber 29, an extractor 31 (shown best in FIGS. 4, 7 and 9), and a spring loaded ejector 32. The trigger 15 is pivotally mounted on a pivot pin 34, the trigger being provided with a sear arm and sear 35 and with a trigger spring 36. Secondary sear 37 is also mounted on the pivot pin 34, the secondary sear being provided with a secondary sear spring 38. A hammer 40 is pivotally mounted on a pivot pin 41 in position to strike the rearward end of the firing pin 30 when the bolt 12 is in its closed position. The hammer 40 is provided with a rearwardly extending sear notch arm having a primary sear notch 43 and a secondary sear notch 44. A hammer strut and spring 46 presses the hammer 40 toward its firing position as shown in FIG. 2.

A magazine 48 adapted to contain a plurality of cartridges 49 is located in the slot 25 of the stock 18 directly below the bolt 12 when the bolt is in its closed position. The magazine 48 advantageously comprises a box-like structure that is removable from the slot 25, the magazine being held in position in the slot by the front magazine latch 50 and the manually operated rear magazine latch 17. A magazine follower 51 is disposed within the magazine 48 below the cartridge 49, the magazine follower having a follower spring 52 (shown best in FIGS. 4 and 7) that presses the magazine follower upwardly, thereby moving the cartridge 49 into position to be loaded into the chamber 29 by the bolt 12.

As noted, the auto-loading mechanism is preferably gas operated, although other types of mechanisms are well known in the art, the action shown in the drawings being a modification of the bolt and auto-loading mechanism of the M-14 rifle. In this modification a slide block (not shown) is located within the channel-shaped recess 26 of the forearm 19, the slide block being connected to the slide 13 and being held in its forward position by the slide spring 54 that is mounted on the slide spring guide rod 55. When the rifle is fired, powder combustion gases drive the slide block rear-

wardly against the pressure of the slide spring 54 thereby causing the bolt 12 to move rearwardly to its open position, the slide spring 54 then moving the bolt 12 forwardly to its closed position in a manner well known in the art.

The firing and auto-loading operations proceed as follows: The rifle is in its cocked and ready to fire condition when the hammer 40 is rotated rearwardly against the pressure of the hammer strut and spring 46 so that the sear notch 43 is engaged and held by the sear 35, the bolt 12 is in its closed position, and a live cartridge is in the chamber 29. When the trigger 15 is pulled, the sear notch 43 is disengaged from the sear 35 thereby allowing the hammer 40 to spring forward against the rearward end of the firing pin 30 which, in turn, strikes and fires the cartridge in the chamber 29. Powder combustion gases force the slide 13 rearwardly against the pressure of the slide spring 54. Rearward movement of the slide 13 causes the bolt 12 to move from its forward closed position to its rearward open position. Rearward movement of the bolt 12 extracts and ejects the spent cartridge case and also rotates the hammer 40 rearwardly so that the secondary sear notch 44 is engaged and held by the secondary sear 37. The pressure of the slide spring 54 then causes the slide 13 to move forward carrying with it the bolt 12. As the bolt 12 moves from its open position to its closed position it picks up a fresh cartridge 49 from the magazine 48 and inserts the cartridge in the chamber 29 in the manner known in the art. When the trigger 15 is released and allowed to return to its usual position, the sear notch 43 is engaged and held by the sear 35 while, at the same time, the secondary sear notch 44 is released by the secondary sear 37. The rifle is now again in its cocked and ready-to-fire condition. This sequence of operations is repeated until the magazine 48 is empty and the last cartridge 49 has been fired.

As previously noted, it is important to provide means for retaining the bolt 12 in its open position when the magazine 48 is empty and the last cartridge is fired. As shown best in FIGS. 3 through 11, the bolt lock means of the invention comprises a longitudinally disposed bolt lock lever 57 pivotally mounted on the generally horizontally disposed pivot stud 58 that projects from the side wall of the receiver 11. The bolt lock lever 57 is provided with a magazine follower engaging arm 60 that extends laterally inwardly from the forward end of the bolt lock lever, and it is also provided with a bolt stop arm 62 that extends laterally inwardly from the rearward end of the bolt lock lever 57. In the embodiment shown in the drawing the bolt lock lever 57 is mounted on the outside of the side wall of the receiver 11, the side wall of the receiver being formed with a forward arm opening 64 through which the magazine follower engaging arm 60 extends and with a rear arm opening 65 through which the bolt stop arm 62 extends. In another embodiment of the invention the bolt lock lever 57 may be mounted within a housing (not shown) that either forms an integral part of the side wall of the receiver 11 or is secured to the side wall of the receiver.

As shown best in FIGS. 9, 10 and 11, the bolt lock lever 57 is held in place on the pivot stud 58 by the retainer plate 67, the retainer plate 67 being received in the slots 68 and 69 and being held in place therein by the retainer plate plunger 70 and plunger spring 71. As noted, the bolt lock lever 57 is pivotally mounted on

the pivot stud 58 so that the magazine follower engaging arm 60 at the forward end of the lever 57 and the bolt stop arm 62 at the rearward end of the lever 57 are movable between predetermined upper and lower positions as hereinafter more fully explained. A bolt lock plunger 72 and bolt lock plunger spring 73 are mounted in a bore 74 formed in the receiver 11, the bolt lock plunger and spring urging the forward end of the bolt lock lever 57 to its lower position and the rearward end of the bolt lock lever to its upper position as shown best in FIG. 3.

The magazine follower 51 of the magazine 48 is provided with an upstanding bolt lock activating surface 76 that is positioned directly below the inner end of the magazine follower engaging arm 60 of the bolt lock lever 57. The spring-pressed magazine follower 51 is disposed in the magazine 48 below any cartridge or cartridges 49 that may be contained in the magazine. As long as there is at least one cartridge 49 remaining in the magazine 48 the bolt lock activating surface 76 is maintained out of contact with the magazine follower engaging arm 60 of the bolt lock lever 57 as shown in FIG. 4. When the last cartridge 49 has been removed from the magazine 48 and the magazine is empty, the bolt lock activating surface 76 of the magazine follower 51 contacts the magazine follower engaging arm 60 of the bolt lock lever 57 and moves the forward end of the bolt lock lever to its upper position as shown in FIGS. 6 and 7. That is to say, when the magazine 48 is empty and the bolt lock activating surface 76 contacts the magazine follower engaging arm 60 the upward force of the magazine follower spring 52 overcomes the downward pressure of the bolt lock plunger spring 73 and causes the forward end of the bolt lock lever 57 to move upwardly as described.

When the magazine follower engaging arm 60 at the forward end of the bolt lock lever 57 is at its lowest position as shown in FIG. 4, the bolt stop arm 62 at the rearward end of the lever 57 is at its upper position as shown in FIG. 5. When the magazine follower engaging arm 60 is at its upper position as shown in FIG. 7, the bolt stop arm 62 is at its lower position as shown in FIG. 8.

As noted, the bolt 12 normally travels from its forward closed position to its rearward open position and then back to its closed position when the rifle is fired. In the embodiment shown in the drawings, the rearward end of the bolt 12 is provided with a bolt stop lug 78 in position to clear (that is, to move freely beneath) the bolt stop arm 62 of the bolt lock lever 57 when the rearward end of the bolt lock lever is at its upper position as shown in FIG. 5. However, the bolt stop lug 78 of the bolt 12 does not clear (that is, it is blocked by) the bolt stop arm 62 of the bolt lock lever 57 when the rearward end of the lever is at its lower position as shown in FIG. 8.

The bolt stop arm 62 of the bolt lock lever 57 is formed with a rearwardly facing surface 80 that is contacted by a matching forwardly facing surface 79 of the bolt stop lug 78 of the bolt 12 when the bolt is at its rearward position and the rearward end of the bolt lock lever 57 is at its lower position as shown best in FIG. 8. The rearward facing surface 80 of the bolt stop arm 62 is slanted slightly rearwardly and the forward facing surface 79 of the bolt stop lug 78 is slanted slightly forwardly so that the forward facing surface 79 of the bolt stop lug 78 slightly overlies the rearward facing surface

80 of the bolt stop arm 62 so as to detain the rearward end of the bolt lock lever 57 at its lower position. This permits the empty magazine 48 to be removed and replaced by a loaded magazine without releasing the bolt lock and thereby allowing the bolt 12 to move forwardly to its closed position. After the loaded magazine is latched in place, the bolt lock is released by pulling on the slide handle 14 which disengages the bolt stop arm 62 and the bolt stop lug 78, thus allowing the lever 57 to return to its normal "unlock" position.

I claim:

1. In an auto-loading firearm having a receiver, a barrel having a chamber secured to the receiver, a bolt mounted for longitudinal travel in the receiver behind the barrel, an auto-loading mechanism connected to the bolt for moving the bolt from a forward closed position to a rearward open position and return when the firearm is fired, a magazine disposed beneath the bolt, said magazine being adapted to contain a plurality of cartridges and having a spring-pressed vertically movable magazine follower that moves the cartridges contained in the magazine upwardly into position to be loaded into the chamber of the barrel, and bolt lock means for locking the bolt in its open position when the magazine is empty and the last cartridge from the magazine has been fired, the improvement in bolt lock means which comprises:

a longitudinally extending bolt lock lever pivotally mounted on the receiver, said bolt lock lever having a magazine follower engaging arm at the forward end thereof and having a bolt stop arm at the rearward end thereof, said forward and rearward ends of said bolt lock lever each being vertically movable between predetermined upper and lower positions when the bolt lock lever is rotated about the pivot thereof,

a bolt lock lever spring that urges the forward end of the pivoted bolt lock lever to its lower position and the rearward end of said bolt lock lever to its upper position,

a bolt stop lug disposed at the rearward end of the bolt in position to be clear of the bolt stop arm of the bolt lock lever when the rearward end of the bolt lock lever is at its upper position and in position to be blocked by the bolt stop arm of the bolt lock lever when the rearward end of the bolt lock lever is at its lower position, and

a bolt lock activating surface disposed on the upper end of the spring-pressed magazine follower in position to contact the magazine follower engaging arm of the bolt lock lever when the magazine is empty, said bolt lock activating surface moving the forward end of the pivoted bolt lock lever to its upper position and moving the rearward end of the pivoted bolt lock lever to its lower position when said magazine is empty.

2. The firearm according to claim 1 in which the bolt lock lever is pivotally mounted on the side of the receiver for rotation about a generally horizontal axis.

3. The firearm according to claim 1 in which the magazine follower engaging arm extends laterally from the forward end of the bolt lock lever and the bolt stop arm extends laterally from the rearward end of the bolt lock lever.

4. The firearm according to claim 1 in which the bolt lock lever is pivotally mounted on the outside of a side wall of the receiver, in which the magazine follower en-

7

8

gaging arm extends laterally inwardly through an opening formed in said side wall above the bolt activating surface of the magazine follower, and in which the bolt stop arm extends laterally inwardly through an opening formed in said side wall adjacent the bolt stop lug of the bolt when the bolt is at its rearward position.

5. The firearm according to claim 1 in which the bolt stop arm of the bolt lock lever is formed with a rearwardly facing surface that is contacted by a matching forwardly facing surface of the bolt stop lug of the bolt when the bolt is at its rearward position and the rear-

ward end of the bolt lock lever is at its lower position.

6. The firearm according to claim 5 in which the rearward facing surface of the bolt stop arm is slanted slightly rearwardly and in which the forward facing surface of the bolt stop lug is slanted slightly forwardly so that said forward facing surface slightly overlies said rearward facing surface to detain the rearward end of the bolt lock lever at its lower position.

* * * * *

15

20

25

30

35

40

45

50

55

60

65