



INTERNATIONAL APPLICATION PUBLISHED UNDER THE PATENT COOPERATION TREATY (PCT)

<p>(51) International Patent Classification⁶ : A61F 2/02</p>	<p>A1</p>	<p>(11) International Publication Number: WO 98/36707 (43) International Publication Date: 27 August 1998 (27.08.98)</p>
<p>(21) International Application Number: PCT/US98/02243 (22) International Filing Date: 6 February 1998 (06.02.98) (30) Priority Data: 08/798,425 7 February 1997 (07.02.97) US 08/798,426 7 February 1997 (07.02.97) US (71) Applicant: SISTERS OF PROVIDENCE IN OREGON [-/US]; 520 Pike Street, P.O. Box 11038, Seattle, WA 98111-9038 (US). (71)(72) Applicant and Inventor: GREGORY, Kenton, W. [US/US]; 3969 Wapato Avenue S.W., Portland, OR 97201 (US). (74) Agents: MARGER, Jerome, S. et al.; Marger, Johnson, McCullom & Stolowitz, P.C., 1030 S.W. Morrison Street, Portland, OR 97205 (US).</p>		<p>(81) Designated States: AL, AM, AT, AU, AZ, BA, BB, BG, BR, BY, CA, CH, CN, CU, CZ, DE, DK, EE, ES, FI, GB, GE, GH, GM, GW, HU, ID, IL, IS, JP, KE, KG, KP, KR, KZ, LC, LK, LR, LS, LT, LU, LV, MD, MG, MK, MN, MW, MX, NO, NZ, PL, PT, RO, RU, SD, SE, SG, SI, SK, SL, TJ, TM, TR, TT, UA, UG, UZ, VN, YU, ZW, ARIPO patent (GH, GM, KE, LS, MW, SD, SZ, UG, ZW), Eurasian patent (AM, AZ, BY, KG, KZ, MD, RU, TJ, TM), European patent (AT, BE, CH, DE, DK, ES, FI, FR, GB, GR, IE, IT, LU, MC, NL, PT, SE), OAPI patent (BF, BJ, CF, CG, CI, CM, GA, GN, ML, MR, NE, SN, TD, TG).</p> <p>Published <i>With international search report. Before the expiration of the time limit for amending the claims and to be republished in the event of the receipt of amendments.</i></p>

(54) Title: METHOD OF PRODUCING BIOMATERIALS

(57) Abstract

It is a general object of the invention to provide a method of effecting tissue repair or replacement using a biomaterial. It is a specific object of the invention to provide a biomaterial suitable for use as a stent, for example, a vascular stent, or as conduit replacement, as an artery, vein or a ureter replacement. The biomaterial can also be used as a stent or conduit covering or lining. The present invention relates to a method of repairing, replacing or supporting a section of a body tissue. The method comprises positioning a biomaterial at the site of the section and bonding the biomaterial to the site or to the tissue surrounding the site. The bonding is effected by contacting the biomaterial and the site, or tissue surrounding the site, at the point at which said bonding is to be effected, with an energy absorbing agent. The agent is then exposed to an amount of energy absorbable by the agent sufficient to bond the biomaterial to the site or to the tissue surrounding the site.

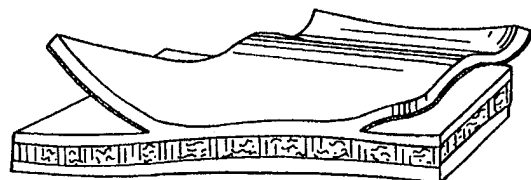
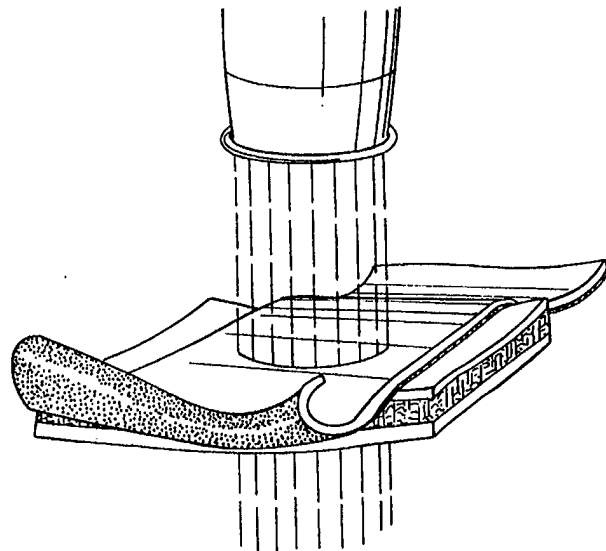

FOR THE PURPOSES OF INFORMATION ONLY

Codes used to identify States party to the PCT on the front pages of pamphlets publishing international applications under the PCT.

AL	Albania	ES	Spain	LS	Lesotho	SI	Slovenia
AM	Armenia	FI	Finland	LT	Lithuania	SK	Slovakia
AT	Austria	FR	France	LU	Luxembourg	SN	Senegal
AU	Australia	GA	Gabon	LV	Latvia	SZ	Swaziland
AZ	Azerbaijan	GB	United Kingdom	MC	Monaco	TD	Chad
BA	Bosnia and Herzegovina	GE	Georgia	MD	Republic of Moldova	TG	Togo
BB	Barbados	GH	Ghana	MG	Madagascar	TJ	Tajikistan
BE	Belgium	GN	Guinea	MK	The former Yugoslav Republic of Macedonia	TM	Turkmenistan
BF	Burkina Faso	GR	Greece	ML	Mali	TR	Turkey
BG	Bulgaria	HU	Hungary	MN	Mongolia	TT	Trinidad and Tobago
BJ	Benin	IE	Ireland	MR	Mauritania	UA	Ukraine
BR	Brazil	IL	Israel	MW	Malawi	UG	Uganda
BY	Belarus	IS	Iceland	MX	Mexico	US	United States of America
CA	Canada	IT	Italy	NE	Niger	UZ	Uzbekistan
CF	Central African Republic	JP	Japan	NL	Netherlands	VN	Viet Nam
CG	Congo	KE	Kenya	NO	Norway	YU	Yugoslavia
CH	Switzerland	KG	Kyrgyzstan	NZ	New Zealand	ZW	Zimbabwe
CI	Côte d'Ivoire	KP	Democratic People's Republic of Korea	PL	Poland		
CM	Cameroon	KR	Republic of Korea	PT	Portugal		
CN	China	KZ	Kazakstan	RO	Romania		
CU	Cuba	LC	Saint Lucia	RU	Russian Federation		
CZ	Czech Republic	LI	Liechtenstein	SD	Sudan		
DE	Germany	LK	Sri Lanka	SE	Sweden		
DK	Denmark	LR	Liberia	SG	Singapore		
EE	Estonia						

METHOD OF PRODUCING BIOMATERIALS

TECHNICAL FIELD

The present invention relates to the biomaterials
5 in tissue repair and replacement. The invention
further relates to methods of securing the biomaterials
to existing tissue.

BACKGROUND OF THE INVENTION

10 Collagen, fibrin, elastin and various other
elastin-based biomaterials are known biomaterials.
Collagen is an insoluble fibrous protein that occurs in
vertebrates as the chief constituent of connective
tissue fibrils and in bones. Fibrin is a white
15 insoluble fibrous protein formed from fibrinogen by the
action of thrombin especially in the clotting of blood.
Elastin is an extracellular matrix protein that is
ubiquitous in mammals. Other biomaterials include
silicone, poly(etherurethane urea), poly(etherurethane),
20 poly(esterurethane), poly(ethylene), poly(prolene),
poly(tetrafluoroethylene), polyvinylidene fluoride,
polycarbonate, poly(ethylene terephthlate), poly(methyl
methacrylate), polystyrene, poly(vinylchloride),
poly(2-hydroxyethylmethacrylate), poly (vinyl-
25 pyrrolidone), poly(acrylonitrile), polyglycolide,
poly(glycolide-L-lactide), poly(ester-ether),
poly(glycolide-E-caprolactone) copolymer, poly-
(glycolide-trimethylene carbonate), random block
copolymer, polyglycolic acid, collagen-based tissues

and matrices, tissue engineered materials, bioartificial tissues(living tissue grafts), and bioinert ceramics.

5 Elastin is an extracellular matrix protein that is ubiquitous in mammals. Elastin is found, for example, in skin, blood vessels, and tissues of the lung where it imparts strength, elasticity and flexibility. In addition, elastin, which is prevalent in the internal elastic lamina (IEL) and external elastic lamina (EEL) of the normal artery, may inhibit the migration of smooth muscle cells into the intima. Elastin in the form of solubilized peptides has been shown to inhibit the migration of smooth muscle cells in response to platelet-derived factors (Ooyama et al, Arteriosclerosis 7:593 (1987)). Elastin repeat hexapeptides attract bovine aortic endothelial cells (Long et al, J. Cell. Physiol. 140:512 (1989) and elastin nonapeptides have been shown to attract fibroblasts (USP 4,976,734). The present invention takes advantage of these physical and biochemical properties of elastin.

10
15
20

Thirty to forty percent of atherosclerotic stenoses that are opened with balloon angioplasty restenose as a result of ingrowth of medial cells. Smooth muscle ingrowth into the intima appears to be more prevalent in sections of the artery where the IEL of the artery is ripped, torn, or missing, as in severe dilatation injury from balloon angioplasty, vessel anastomoses, or other vessel trauma that results in tearing or removal of the elastic lamina. While repair of the arterial wall occurs following injury, the

25
30

elastin structures IEL and EEL do not reorganize. Since these components play major structural and regulatory roles, their destruction is accompanied by muscle cell migration. There are also diseases that are associated with weakness in the vessel wall that result in aneurysms that can ultimately rupture, as well as other events that are, at least in part, related to abnormalities of elastin.

Prosthetic devices, such as vascular stents, have been used with some success to overcome the problems of restenosis or re-narrowing of the vessel wall resulting from ingrowth of muscle cells following injury. However, their use is often associated with thrombosis. In addition, prosthetic devices can exacerbate underlying atherosclerosis. Nonetheless, prostheses are often used.

Until relatively recently, the primary methods available for securing a prosthetic material to tissue (or tissue to tissue) involved the use of sutures or staples. Fibrin glue, a fibrin polymer polymerized with thrombin, has also been used (primarily in Europe) as a tissue sealant and hemostatic agent.

Laser energy has been shown to be effective in tissue welding arterial incisions, which is thought to occur through thermal melting of fibrin, collagen and other proteins. The use of photosensitizing dyes enhances the selective delivery of the laser energy to the target site and permits the use of lower power laser systems, both of which factors reduce the extent of undesirable thermal trauma.

OBJECTS AND SUMMARY OF THE INVENTION

It is a general object of the invention to provide a method of effecting tissue repair or replacement using a biomaterial or supporting a section of a body tissue.

It is a specific object of the invention to provide an biomaterial suitable for use as a stent, for example, a vascular stent, or as conduit replacement, for example, as an artery, vein or a ureter replacement. The biomaterial can also be used as a stent or conduit covering or coating or lining.

It is a further object of the invention to provide a biomaterial graft suitable for use in repairing a lumen wall.

It is another object of the invention to provide a biomaterial material suitable for use in tissue replacement or repair, for example, in interior bladder replacement or repair, intestine, tube replacement or repair such as fallopian tubes, esophagus such as for esophageal varicies, ureter, artery such as for aneurysm, vein, stomach, lung, heart such as congenital cardiac repair, or colon repair or replacement, or skin repair or replacement, or as a cosmetic implantation or breast implant.

It is also an object of the invention to provide a method of securing a biomaterial to an existing tissue without the use of sutures or staples.

The subject invention is directed to a method for producing biomaterials which can be used in biomedical

applications, or the biomaterial can be fused onto a tissue substrate, or the biomaterial can itself be used. The invention can be also directed to a method for using fusible biomaterial, to a method for producing a biomaterial fused onto a tissue substrate, to a prosthetic device, and to a method of producing a prosthetic device including such biomaterials.

The present invention relates to a method of repairing, replacing or supporting a section of a body tissue, preferably a live tissue substrate. The method comprises positioning a biomaterial at the site of the section and bonding the biomaterial to the site or to the tissue surrounding the site. The bonding is effected by contacting the biomaterial and the site, or tissue surrounding the site, at the point at which said bonding is to be effected, with an energy absorbing agent. The agent is then exposed to an amount of energy absorbable by the agent sufficient to bond the biomaterial to the site or to the tissue surrounding the site.

More specifically, a tissue-fusible biomaterial can be produced using the process of the present invention which comprises a layer of a biomaterial and a tissue substrate each having first and second outer surfaces, and an energy absorbing material applied to at least one of the outer surfaces. Preferably, the energy absorbing material penetrates into the biomaterial.

The energy absorbing material is energy absorptive within a predetermined range of light wavelengths

depending on material thickness. The energy absorbing material is chosen so that when it is irradiated with light energy in the predetermined wavelength range, the intensity of that light will be sufficient to fuse
5 together one of the first and second outer surfaces of the biomaterial and the tissue substrate. Preferably, the first and second outer surfaces of the biomaterial are major surfaces. Typically, the energy absorbing material is indirectly irradiated by directing the
10 light energy first through the biomaterial or tissue substrate and then to the energy absorbing material.

In a preferred process of this invention, the energy absorbing material comprises a biocompatible chromophore, more preferably an energy absorbing dye.
15 In one form of the present invention, the energy absorbing material is substantially dissipated when the biomaterial and the tissue substrate are fused together. In another form of this invention, the energy absorbing material comprises a material for
20 staining the first or second surface of the biomaterial. The energy absorbing material can also be applied to one of the outer surfaces of the biomaterial by doping a separate biomaterial layer with an energy absorbing material and then fusing the doped separate
25 biomaterial layer to the biomaterial. In any case, the energy absorbing layer is preferably substantially uniformly applied to a portion of at least one of the outer surfaces, and more preferably in a manner wherein the energy absorbing material substantially covers
30 substantially the entire outer surface of the bio-

material. Although the energy absorbing material can be applied directly to the tissue substrate, it is not the preferred method because of the difficulty in controlling penetration into the interstices of the tissue substrate.

Some of the key properties which effect the process of the present invention regarding fusing the biomaterial and tissue substrate include the magnitude of the wave length, energy level, absorption, and light intensity during irradiation with light energy of the energy absorbing material, and the concentration of the energy absorbing material. These properties are arranged so that the temperature during irradiation with light energy for period of time which will cause fusing together of one of the first and second outer surfaces of the biomaterial and the tissue substrate is from about 40 to 140 degrees C., and more preferably from about 50 to 100 degrees C., but if well localized to the biomaterial tissue interface can be as high as 600 degrees C. Furthermore, the average thickness of the energy absorbing material in the preferred process of this invention is from about 0.5 to 300 microns.

The subject invention provides a biocompatible biomaterial formed into a three-dimensional structure. This structure can be used, for example, in a stromal support matrix populated with actively growing stromal cells. The stromal support matrix, which are preferably fibroblasts, can then be used to provide support, growth factors, and regulatory factors needed to sustain long-term active proliferation of cells in

culture. A living stromal tissue can be prepared comprising stromal cells and connective tissue proteins naturally secreted by the stromal cells which are attached to and substantially enveloping a framework composed of a biocompatible, non-living material formed into three dimensional structure having interstitial spaces bridged by the stromal cells. The stromal cell systems contemplated herein are described in the following U.S. patents of Advanced Tissue Sciences, Inc. (formerly Marrow-Tech Incorporated), which are incorporated herein by reference: US 5,478,739, US 5,460,939, US 5,443,550, US 5,266,480, US 5,518,915, US 5,516,681, US 4,963,489, US 5,032,508, US 4,721,096, US 5,516,680, US 5,512,475, US 5,510,254, and US 5,160,490.

The biomaterial structures can also have a cellular lining of human cells. The cells can be derived autologously, or otherwise, and formed into a lining on one of the major surfaces of the elastin and elastin-based biomaterials layer. Preferably, the cells which are employed to form such a lining are endothelial cells and/or epithelial cells and/or urothelial cells.

The present invention also relates to a method of repairing, replacing or supporting a section of a body tissue using biomaterials. The method comprises positioning biomaterials at the site of the section and bonding the biomaterial to the site or to the tissue surrounding the site. The bonding is effected by contacting the biomaterial and the site, or tissue

surrounding the site, at the point at which said bonding is to be effected, with an energy absorbing agent. The agent is then exposed to an amount of energy absorbable by the agent sufficient to bond the biomaterial to the site or to the tissue surrounding the site.

The absorbing material can comprise bio-compatible materials, preferably energy absorbing dye. In one form of the present invention, the energy absorbing material is substantially dissipated when the biomaterial and the tissue substrate are fused together. In another form of this invention, the energy absorbing material comprises a material for staining the first or second surface of the elastin or elastin-based biomaterial. The energy absorbing material can also be applied to one of the outer surfaces of the biomaterial by doping a separate elastin layer with an energy absorbing material and then fusing the doped separate elastin layer to the biomaterials. In any case, the energy absorbing layer is preferably substantially uniformly applied to at least one of the outer surfaces, typically in a manner wherein the energy absorbing material substantially covers the entire outer surface of the biomaterial.

Some of the key properties which effect the method of the present invention regarding fusing the biomaterial and tissue substrate include the magnitude of the wavelength, energy level, absorption, and light intensity during irradiation with light energy of the energy absorbing material, and the concentration of the

energy absorbing material. These properties are arranged so that the temperature during irradiation with light energy for period of time which will cause fusing together of one of the first and second outer surfaces of the biomaterial and the tissue substrate is from about 40 to 140 degrees C., and more preferably from about 50 to 100 degrees C., but if well localized to the biomaterial tissue interface can be as high as 600 degrees C. Furthermore, the average thickness of the energy absorbing material in the preferred method of this invention is from about 0.5 to 300 microns.

Further objects and advantages of the invention will be clear from the description that follows.

Further objects and advantages of the invention will be clear from the description that follows.

BRIEF DESCRIPTION OF THE DRAWINGS

FIGURE 1. Application of laser energy to biomaterial and exposed native tissue.

FIGURE 2 Placement of biomaterial into artery.

FIGURE 3. Use of biomaterial as intestinal patch.

FIGURE 4. Scanning electron micrograph of biomaterial (prepared according to Rabaud et al using elastin, fibrinogen and thrombin) fused to porcine aorta using continuous wave diode laser.

FIGURE 5. Light microscopic picture of biomaterial fused to porcine aorta using a pulsed diode laser, where E = elastin biomaterial; A = aorta.

FIGURE 6. Light microscopic photomicrograph of biomaterial derived from arterial digest welded to

porcine carotid artery, where E = elastin biomaterial;
A = aorta.

DETAILED DESCRIPTION OF THE INVENTION

5 The present invention relates to biomaterials and
to methods fusing of such biomaterials to tissue using
laser energy. Biomaterials suitable for use in the
present invention can be prepared, for example, from
elastin (from bovine nuchal ligament), fibrinogen and
10 thrombin as described by Rabaud et al (USP 5,223,420),
as well as from collagen, fibrin, and various other
known biomaterials. (See also Aprahamian et al, J.
Biomed. Mat. Res. 21:965 (1987); Rabaud et al, Thromb.
Res. 43:205 (1986); Martin, Biomaterials 9:519 (1988).
15 Such biomaterials can have associated thrombogenic
property that can be advantageous in certain types of
tissue repair. Biomaterials suitable for use in the
invention can also be prepared from elastin and type
III collagen, also as described by Rabaud and
20 co-workers (Lefebvre et al, Biomaterials 13(1):28-33
(1992). Such preparations are not thrombogenic and
thus can be used for vascular stents, etc. A further
type of biomaterial suitable for use in the present
invention is prepared as described by Urry et al (see,
25 for example, USP 4,132,746 and 4,500,700) (See also
USP's 4,187,852, 4,589,882, 4,693,718, 4,783,523,
4,870,055, 5,064,430, 5,336,256). Elastin matrices
resulting from digestion of elastin-containing tissues
(eg arteries) can also be used. Digestion results in
30 the removal of cells, proteins and fats but maintenance

of the intact elastin matrix. The biomaterial used will depend on the particular application.

Biomaterial of the invention prepared from soluble elastin (see Rabaud et al above) can be molded so as to render it a suitable size and shape for any specific purpose. Molded biomaterial can be prepared as follows. Elastin (eg soluble elastin MW 12-32,000 daltons) is washed and swollen in buffer. Fibrinogen or cryoglobulins (prepared, for example, according to Pool et al, New Engl. J. Med. 273 (1965) are added to the swollen elastin, followed by thiourea, with or without a protease inhibitor (such as aprotinin), and collagen. Thrombin is added with stirring and the resulting mixture is immediately poured into an appropriate mold.

The mold is then incubated (for example, at 37°C) while polymerization of the fibrin/elastin material is allowed to proceed, advantageously, for from between 15 minutes to 1 hour, 30 minutes being preferred. The reaction can be carried out at temperatures less than 37°C., but the reaction proceeds more rapidly at 77°C. Heating the reaction to over 40°C, however, can result in denaturation of the thrombin. Cooling of the mixture while stirring allows more time for mixing to occur. For polymerization to occur, it is important to have calcium and magnesium in the buffer and to use undenatured thrombin.

Following polymerization in the mold, the resulting biomaterial can be further cross-linked using gamma radiation or an agent such as glutaraldehyde (a solution of glutaraldehyde, formic acid and picric acid

being preferred). When radiation is used, the samples are, advantageously, subjected to gamma-irradiation from a Cobalt-60 source. The amount of irradiation can range, for example, from 10 to 100MRAD, with 25MRAD being preferred. It has been shown that the amount of gamma-irradiation can affect the strength of the material (Aprahamian, J. Biomed. Mat. Res. 21:965 (1987)).

Sheets of biomaterial can be prepared that are of a controlled thicknesses by using appropriate molds. Sheets of the biomaterial can be made in thicknesses ranging, for example, from 200 microns to 5 mm. Sheets are generally made as thin as possible to allow for penetration of laser energy while maintaining sufficient strength. By way of example, a sheet suitable for use as an intestinal patch can range in thickness from 200 microns to 5 mm, with about 2 mm being preferred. A patch requiring greater strength, such a patch for use in the bladder, is typically thicker. Arterial stents or patches can be thinner (eg 100 μm - 1000 μm).

Biomaterial prepared from soluble elastic or insoluble elastin fragments can also be molded into tubular segments for example, by injecting the material into tubular molds. Crosslinkage of the elastin solution present between the inner and outer tubes can be effected prior to withdrawal of biomaterial from the mold or after the tubes are removed. Tubular segments of different inner and outer diameters, as well as of different lengths, can be prepared using this approach

by varying the diameters of the inner and outer tubes. A mold of this type can be made in virtually any size with the inner and outer tubes varying in diameter. A small tube can be used for a coronary arterial stent. A large tube of 1-5 inches in diameter can be made and used as an angularly welded patch for anastomosis of the small intestine or colon. Various molding techniques and molding materials can be used; the foregoing is merely an example.

As indicated above, biomaterial suitable for use in the present invention can be prepared from digests of tissue containing an elastin matrix. Tissues suitable for use as a starting material include arteries (e.g. coronary or femoral arteries, for example, from swine), umbilical cords, intestines, ureters, etc. Preferably, the matrix material is (derived from the species of animal in which the implantation is being performed so that bio-compatibility is increased. Any method of removing (digesting away) cellular material, proteins and fats from the native matrix while leaving the extracellular elastin matrix intact can be used. These methods can involve a combination of acidic, basic, detergent, enzymatic, thermal or erosive means, as well as the use of organic solvents. This may include incubation in solutions of sodium hydroxide, formic acid, trypsin, guanidine, ethanol, diethylether, acetone, t-butanol, and sonication. Typically, the digestion proceeds more quickly at higher temperatures. The optimal temperature and time (of incubation depend on the

starting material and digestive agent used, and can be readily determined.

One skilled in the art will appreciate that while tubular segments result from digestion of tubular starting materials, those segment can be opened and shaped to yield sheets suitable for use as tissue grafts. Alternatively, such segments can be opened and then reconstructed as tubular segments having a diameter different than the starting tissue.

Preferably, however, when tubular products are sought, the starting material is selected so as to yield a tubular segment after digestion having the appropriate diameter so that subsequent manipulations (other than adjustment of length) can be avoided.

The biomaterial of the invention, whether prepared from elastin powder or from tissues digests, is normally secured to existing tissue. Various techniques for effecting that attachment can be used, including art-recognized techniques. However, it is preferred that the biomaterial be secured using a tissue welding energy source and an agent that absorbs energy emitted by that source. Advantageously, the energy source is an electromagnetic energy source, such as a laser, and the absorbing agent is a dye having an absorption peak at a wavelength corresponding to that of the laser. The elastin biomaterial and the tissue to be welded have much less absorption of light at this wavelength and the effect therefore is confined to a zone around the dye layer. A preferred energy source is a laser diode having a dominant wavelength at

about 808 nm and a preferred dye is indocyanine green (ICG), maximum absorbance 795-805 nm (see WO 91/,4073). Other laser/dye combinations can also be used. It is preferred that the dye be applied to that portion of the biomaterial that is to be contacted with and secured to the existing tissue. The dye can also be applied to the surface of the structure to which the elastin biomaterial is to be welded or secured. The dye can be applied directly to the biomaterial or the surface of the biomaterial can first be treated or coated (eg primed) with a composition that controls absorption of the dye into the biomaterial so that the dye is kept as a discrete layer or coating. Alternatively, the dye can be bound to the elastin biomaterial so that it is secured to the surface and prevented from leeching into the material. The dye can be applied in the form of a solution or the dye can be dissolved in or suspended in a medium which then can be applied as a thin sheet or film, preferably, of uniform thickness and dye concentration.

Tissue welding techniques employing a soldering agent can be used. Such techniques are known (WO 91/04073). Any proteinaceous material that thermally denatures upon heating can be used as the soldering agent (for example, any serum protein such as albumin, fibronectin, Von Willebrand factor, vitronectin, or any mixture of proteins or peptides). Solders comprising thrombin polymerized fibrinogen are preferred, except where such materials would cause undesirable thrombosis or coagulation such as within vascular lumens. Solders

are selected for their ability to impart greater adhesive strength between the biomaterial and the tissue. The solder should be non-toxic and generally biocompatible.

5 In accordance with the present invention, the laser energy can be directed to the target site (eg, the dye) directly from the laser by exposure of the tissue (eg, during a surgical procedures). In some cases, i.e. endovascular catheter-based treatments
10 where open surgical exposure does not occur, the laser energy is directed to the bonding site via optical fibers. When ICG is used as the dye, targeting media wavelengths of around 800nm can be used. Such wavelengths are not well absorbed by many tissues,
15 particularly vascular tissues, therefore, there will be a negligible effect on these tissues and thermal effects will be confined to the dye layer. The biomaterial of the invention similarly has little optical absorbance in this waveband, as compared to the
20 energy absorbing dye. Thus, the laser energy can pass through either the biomaterial or the native tissue and be absorbed by the dye layer as shown in Figure 1. Once the surgeon has exposed the surface or vessel where the biomaterial reinforcement or replacement is to be
25 effected, the dye-containing surface of the biomaterial is placed in contact with the native tissue at the site and laser energy delivered by directing the laser beam to the desired location. The absorbance of the dye (eg ICG) layer is ideally previously or concurrently
30 determined so that the optimal amount of light for

optimal bonding can be delivered. Pressure can be used to ensure adequate approximation of the tissue and biomaterial. With a diode laser source, the diode laser itself, or a condenser or optical fiber based optical delivery system, can be placed against the material to ensure uniform light delivery.

In cases where a new elastin lining or new-internal elastic lamina is required, for example, following an open surgical endarterectomy, once the artery has been surgically cleared of the atheroma or other lesion, the biomaterial is then put in place, dye side down (see Figure 2). The biomaterial can be deployed as a flat patch or as a tubular segment. A tubular segment can be hollow or filled with a material that supports the lumen during placement and that is melted with low grade heat or dissolved or removed with a variety of means. When necessary, a small number of surgical sutures (eg stay sutures) can be used to appose the edges of the vessel together or to sew the vessel. Once the biomaterial is in place, the laser energy is directed through the vessel wall or through the biomaterial to the absorbing dye, the appropriate laser energy having been previously determined based upon the measured absorbance in the biomaterial.

Alternatively, the dye can be applied at the time of the surgery to the biomaterial or the vessel wall or both and then laser energy delivered. In this embodiment, absorbance can be determined at the time of the surgery to the biomaterial or the vessel wall or both and then laser energy delivered or with a feedback

device that assesses the adequacy of the bonding or thermal effect. (Figure 4 is a SEM of elastin-based biomaterial fused to porcine aorta.)

5 In addition to the above, the biomaterial of the invention can be used as a patch material for use in intestinal or colon repairs which frequently do not heal well with current techniques, particularly when the patient has nutritional or other problems or when the patient is in shock, such as in the case of
10 multiple gunshot wounds or other abdominal injuries (see Figure 3). The use of such a patch can, for example, seal off intestinal contents and thereby reduce the likelihood of peritonitis. In addition, a patch can be used on a solid organ, such as the liver,
15 when lacerations have occurred. Similarly, the biomaterial of the invention can be used to repair or replace portions of the urinary system i.e., from the calyces of the kidney on down to the urethra. The patch can also be used to seal a defect in a cardiac
20 chamber, such as an atrial septal defect, as well as bronchial or rectal fistulas. The biomaterial can also be used as a cerebrovascular patch for an aneurysm. The biomaterial can be sealed in place with targeted laser fusion. For applications where direct
25 exposure is not possible or not desirable, a variety of catheter or endoscopic systems can be employed to direct the laser energy to the target site.

30 The elastin-based biomaterials to which the invention relates can be used in a variety of other clinical and surgical settings to effect tissue repair

graft. For delivery of biomaterial in the form of an intravascular stent, the biomaterial can be pre-mounted upon a deflated balloon catheter. The balloon catheter can be maneuvered into the desired arterial or venous location using standard techniques. The balloon can then be inflated, compressing the stent (biomaterial) against the vessel wall and then laser light delivered through the balloon to seal the stent in place (the dye can be present on the outside of the biomaterial). The balloon can then be deflated and removed leaving the stent in place. A protective sleeve (eg of plastic) can be used to protect the stent during its passage to the vessel and then withdrawn once the stent is in the desired location.

The biomaterial of the invention can also be used as a biocompatible covering for a metal or synthetic scaffold or stent. In such cases, simple mechanical deployment can be used without the necessity for laser bonding. Laser bonding can be employed, however, depending upon specific demands, eg, where inadequate mechanical bonding occurs, such as in stent deployment for abdominal aortic aneurysms. An alternative catheter-based vascular stent deployment strategy employs a temporary mechanical stent with or without a balloon delivery device.

A further catheter-based vascular stent deployment strategy employs a heat deformable metal (such as nitinol or other similar type metal) scaffold or stent or coating that is incorporated into the catheter tubing beneath the stent biomaterial. The stent is

maneuvered into the desired location whereupon the deformable metal of the stent is activated such that it apposes the stent against the vessel wall. Laser light is then delivered via an optical fiber based system, also incorporated into the catheter assembly.

The biomaterial can also be used to replace portions of diseased or damaged vascular or nonvascular tissue such as esophagus, pericardium, lung plura, etc. The biomaterial can also be used as a skin layer replacement, for example, in burn or wound treatments. As such, the biomaterial serves as a permanent dressing that acts as a scaffolding for epithelial cell regrowth. The biomaterial can include antibiotics, coagulants or other drugs desirable for various treatments that provide high local concentrations with minimal systemic drug levels. The elastin biomaterial can be deployed with a dye on the tissue side and then fused with the appropriate wavelength and laser energy.

In addition to repair of tubular body structures, the biomaterial of the present invention can also be used in organ reconstruction. For example, the biomaterial can be molded or otherwise shaped as a pouch suitable for use in bladder reconstruction. The biomaterial of the invention can also be molded or otherwise shaped so as to be suitable for esophageal replacement. Again, metal or synthetic mesh could also be associated with the implant if extra wall support is needed so as to control passage of food from the pharynx to the stomach. This could be used for stenosis of the esophagus, as a covering for bleeding

esophogel varicies to prevent bleeding or to treat
bleeding, for repair from acid reflux for erosive
esophagitis or, more preferably, for refurbishing
damaged esophageal segments during or following surgery
or chemotherapy for esophageal carcinoma.

For certain applications, it may be desirable to
use the biomaterial of the invention in combination
with a supporting material having strong mechanical
properties. For those applications, the biomaterial
can be coated on the supporting material (see foregoing
stent description), for example, using the molding
techniques described herein. Suitable supporting
materials include polymers, such as woven polyethylene
terephthalate (Dacron), teflon, polyolefin copolymer,
polyurethane polyvinyl alcohol or other polymer. In
addition, a polymer that is a hybrid between a natural
polymer, such as fibrin and elastin, and a non-natural
polymer such as a polyurethane, polyacrylic acid or
polyvinyl alcohol can be used (sets Giusti et al,
Trends in Polymer Science 1:261 (1993)). Such a hybrid
material has the advantageous mechanical properties of
the polymer and the desired biocompatibility of the
elastin based material. Examples of other prostheses
that can be made from synthetics (or metals coated with
the elastin biomaterial or from the biomaterial/
synthetic hybrids include cardiac valve rings and
esophageal stents.

The prostheses of the invention can be prepared so
as to include drug; that can be delivered, via the
prostheses, to particular body sites. For example,

vascular stents can be produced so as to include drugs that prevent coagulation, such as heparin, or antiplatelet drugs such as hirudin, drugs to prevent smooth muscle ingrowth or drugs to stimulate
5 endothelial damaged esophageal segments during or following surgery or chemotherapy for esophageal carcinoma.

For certain applications, it may be desirable to use the biomaterial of the invention in combination
10 with a supporting material having strong mechanical properties. For those applications, the biomaterial can be coated on the supporting material (see foregoing stent description), for example, using the molding techniques described herein. Suitable supporting
15 materials include polymers, such as woven polyethylene terephthalate (Dacron), teflon, polyolefin copolymer, polyurethane polyvinyl alcohol or other polymer. In addition, a polymer that is a hybrid between a natural polymer, such as fibrin and elastin, and a non-natural
20 polymer such as a polyurethane, polyacrylic acid or polyvinyl alcohol can be used (sets Giusti et al, Trends in Polymer Science 1:261 (1993). Such a hybrid material has the advantageous mechanical properties of the polymer and the desired biocompatibility of the
25 elastin based material. Examples of other prostheses that can be made from synthetics or metals coated with the elastin biomaterial or from the biomaterial/ synthetic hybrids include cardiac valve rings and esophageal stents.

The elastin-based prostheses of the invention can be prepared so as to include drug; that can be delivered, via the prostheses, to particular body sites. For example, vascular stents can be produced so as to include drugs that prevent coagulation, such as heparin, drugs to prevent smooth muscle ingrowth or drugs to stimulate endothelial regrowth. Vasodilators can also be included. Prostheses formed from the elastin based biomaterial can also be coated with viable cells, preferable, cells from the recipient of the prosthetic device. Endothelial cells, preferably autologous (eg harvested during liposuction), can be seeded onto the elastin bioprosthesis prior to implantation (eg for vascular stent indications). Alternatively, the elastin biomaterial can be used as a skin replacement or repair media where cultured skin cells can be placed on the biomaterial prior to implantation. Skin cells can thus be used to coat elastin biomaterial.

Biomaterial structures constituting a framework for a three-dimensional, multi-layer cell culture system will provide intact elastic structures not constructed by stromal cells populating synthetic matrices. In vivo elastin production, for example, is thought to only occur during development and ceases during childhood (the only exceptions being hypertension and restenosis). Elastogenesis is a complex process and formation of mature elastic structures not likely to be achieved in relatively simple in vitro cell culture systems. However, it has

not been reported that such three dimensional cell culture systems can organize elastin into coherent fibrous matrices analogous to those found in elastic tissues. A method by which to produce a living tissue graft with elastic structure and function most similar to tissue which is high in elastin content is by culturing cells in three dimensional frameworks made of biomaterials. This insures the presence of biologically important elastic structures in the living tissue grafts.

A method for both organizing biomaterials fibrils and providing a support for fibroblast growth is by coacervating elastin monomers in solution with fibroblasts. Elastin monomers mixed with stromal cells (fibroblasts) in a physiologic buffer aggregate into fibers (coacervation) upon raising the temperature of the solution. In doing so the fibroblasts become trapped in a loose matrix of elastin fibers. The contraction of the fibroblasts bound to the coacervated elastin monomers could preferentially align the elastin fibrils prior to crosslinking.

Certain aspects of the invention are described in greater detail in the non-limiting Examples that follow.

Example 1 Preparation of Sheets of Elastin-Based Biomaterial from Soluble Peptides

Materials used for biomaterial production:

Phosphate buffer: The phosphate buffer used

contained 1 mM sodium phosphate, 150 mM sodium chloride, 2 mM calcium chloride, 1 mM magnesium (chloride, pH 7.4. Soluble elastin peptides: Bovine ligamentum nuchae elastin powder was obtained

5 from Sigma, St. Louis, Missouri. The following procedure was used to obtain the soluble elastin peptides: 2.7 g elastin powder was suspended in 35 ml of a 1M KOL solution in 80% ethanol. The suspension was stirred at 50°C for 2.5 hr. Next, 10 ml deionized

10 water was added and the solution neutralized with concentrated 12M HCl to pH 7.4. The solution was cooled at 4°C for 12 hrs. The clear solution was decanted from the salt crystals, and the supernatant centrifuged for 15 mins at 2000 rpm. The solution was

15 then dialyzed against three changes of tap water at two hour intervals and one 15 hr interval using a 10,000 MW cutoff dialysis tubing. The dialysis was continued with six changes of deionized water at two hour intervals and one for 15 hrs. The resulting dialyZate

20 was lyophilized and stored at -20°C. The yield was 40%.

Cryoglobulin preparation: A modification of the method of Pool and Shannon was used to Produce the cryoglobulins (New Engl. J. Med. 273 (1965).

25 Cryoglobulins are principally fibrinogen (40 mg/ml) and fibronectin (10 mg/ml) (concentrations of fibrinogen and fibronectin will vary). Briefly, blood was collected from swine in a standard 500 ml blood collection bag containing adenine, citrate and dextrose

30 anticoagulant. The blood was transferred to twelve 50

ml plastic centrifuge tubes and centrifuged for 15 mins at 1500 rpm. The plasma was decanted from the erythrocyte layer and frozen at -70°C for 12 hrs. The plasma was then thawed at 4°C. The cryoglobulins were collected by centrifugation of the plasma at 4°C for 15 mins at 1500 rpm. The supernatant was decanted and the cryoglobulins collected by removing the precipitate with a pasteur pipette. Each tube was also rinsed with 3 ml of a sodium citrate solution containing 0.9% NaCl, and 0.66% sodium citrate. The cryoglobulins were pooled, frozen at -70°C, lyophilized and stored at -20°C until use.

Thiourea: Reagent grade thiourea. was obtained from Sigma, St. Louis, Missouri. A 0.5 mg/ml solution was used.

Type I collagen: Acid soluble type I collagen was obtained from Sigma. It was preferred from rat tail tendon by a modification of the method of Bornstein. Two mg of collagen was heated in 0.6 ml phosphate buffer to 60°C for 10 minutes until the collagen dissolved. It was then cooled to 37°C and used.

Thrombin: Thrombin from bovine plasma was obtained from Sigma in lyophilized form. When reconstituted with 1 ml water, the solution contained 106 NIH units per ml.

Aprotinin: Aprotinin from bovin lung was obtained from Sigma. It contained 15-30 trypsin inhibitory units (TIU) per ml.

Preparation:

Six molds were made by gluing a 620 μm quartz fiber to one side of a glass plate ~40 mm x 25 mm and attaching a second glass plate to the first using a rubber band. Each mold so constructed held about 0.5 ml.

The biomaterial was prepared by successively adding and mixing the following: 200 mg soluble kappa-elastin or kappa-elastin powder in 2ml phosphate buffer (PB) (1 mM P041 150 mM NaCl, 2 mM Ca21 1 mM Mg21 PH 7.4) at 37°C

160 mg cryoglobulin in 1 ml P:B (37°C)

2 mg collagen in 0.6 ml PB (60°C 37°C)

200 μl thiourea (0.5 mg/ml)

200 μl aprotinin (5 Units)

A 0.6 ml aliquot of the above solution was loaded into a test tube and 50 μl thrombin solution was added (~6 units). The resulting solution was immediately loaded into the mold. Certain of the resulting sheets were crosslinked with glutaraldehyde for 2 mins.

Results: The sheets prepared as described above were slightly yellowish and opaque. The glutaraldehyde-fixed sheets were less stretchy and tore more easily than non-fixed sheets. Glutaraldehyde fixed sheets were subjected to electron microscopy. These sheets had a smooth cohesive surface appearance at 100X and 1000X.

Example 2 Tissue Welding of Sheets of Elastin-Based Biomaterial

Pre-welding procedure: A 1 mg/ml ICG solution was applied to fresh swine aorta that had been carefully trimmed of adventitia, washed in a sterile 0.9% NaCl solution, and cut into 1cm² squares. The 1mg/ml ICG solution was applied to the luminal side of the aorta for ~3 min and wiped off. (ICG was obtained from Sigma and contained 90% dye and 10% sodium iodide. Absorption coefficient measured at 780 nm with a 7.25 X 10⁻⁶ M solution was found to be 175,000 M⁻¹cm⁻¹. The adsorption maximum shifts to 805nm when ICG is bound to serum proteins (Landsman et al, J. Appl. Physiol. 40 (1976). A small amount of cryoglobulins, containing approximately 40mg/ml fibrinogen and 10mg/ml fibronectin doped with ICG, was also applied and the biomaterial placed on it. The two materials were placed between two glass slides. This was submerged in a 0.9% saline solution.

Welding Procedure: Sheets of biomaterial made as described in Example 1 were equilibrated in phosphate buffer, pH 7.4, and welded to ICG stained porcine aorta using an aluminum gallium arsenide diode array laser. The maximum output was at 808 +/- 1.5nm. The laser was coupled to a 1 μ m quartz fiber with polyethylene cladding material. The laser energy was collimated with a focusing lens and coupled to the quartz fiber. The spot size at the distal end of the fiber could be varied from 1mm to 4mm by adjusting the

distance between the focusing lens and the proximal end of the fiber. The laser operated continuously, CW, and the output measured at the distal end of the fiber was 1.5W.

5 The quartz fiber was positioned directly above the glass slide, biomaterial, aorta. Before welding, the spot size of the laser was measured. Welding appeared to occur under saline at irradiances of 0.85W but not 1.32W. Twenty seconds was sufficient
10 time to weld and 40 seconds caused a brown color change and charring of the biomaterial.

Example 3 Preparation of Elastin-Based Biomaterial from Artery Digest

15 Fresh 4 cm lengths of porcine carotid artery were dissected clean and washed in two changes of 0.9% saline overnight. Vessels were then placed in 0.5M NaOH and sonicated for 120 minutes (a modified method of Crissman, R. 1987) See Crissman, Rogert S.
20 "Comparison of Two Digestive Techniques for Preparation of Vascular Elastic Networks for SEM Observation", Journal of Electron Microscopy Techniques 6:335-348 (1987). Digested vessels were then washed in distilled water and autoclaved at 225°F for 30 minutes. Digested
25 vessels appear translucent, pearly white in color and collapsed when removed from water indicating the absence of collagen and other structurally supportive proteins.

30 Welding of the artery digests to porcine aorta was accomplished through the following methods. Fresh

porcine aorta was coated with 5 mJ/ml ICG for 5 minutes. Excess ICG solution was blotted off. One x one cm sections of NaOH-sonicated digested carotid artery elastin segments were placed upon the freshly stained aortas. An array of pulsed aluminum gallium arsenide diode lasers (Star Medical Technologies) was used to weld the segments. Five millisecond pulses at 790-810 light was emitted at 2 joules and applied to the tissue with a condenser that created a uniform beam 4x4 mm which was placed on the elastin digest covered by a glass coverslip. Good welds were achieved with up to 10 pulses. A light microscopic photograph of the elastin digest welded to the porcine aorta is shown in Figure 6.

Example 4 Preparation of Elastin-Based Biomaterial & Fusion to Porcine Aorta

Materials: Bovine nuchal elastin powder (Sigma St. Louis MO) Was sifted with a 40 μ m screen and swollen with phosphate buffer. Elastin fragments were then reacted with 67 mg of fibrinogen (Sigma):in phosphate buffer, 2m acid soluble Type 1 collagen (Sigma), 2.8 mg thiourea, 2 mM Ca^{2+} , 1mM Mg^{2+} and 75 units of thrombin and injected into molds and heated to 77°C. One mm thick sheets and tubes of this biomaterial were removed and stored in 33% ethanol for later use.

Indocyanine green dye was dissolved in de-ionized water to provide a 1% solution and applied to the luminal surface of fresh porcine aorta. The dye was in

place for 5 minutes then the residual dye was blotted off. The elastin biomaterial was placed on the ICG stained aorta and covered with a glass coverslip. Laser energy was applied with a condenser which collected the output of an array of gallium arsenide diode lasers emitting light at 800nm in 5 msec pulses. Six mm² spots were irradiated with 2.89 Joules for 1-10 pulses which provided adequate welds. Samples were then bisected and fixed in formalin for microscopic study. Figure 5 is a light microscopic photograph of such a weld stained with an elastin stain. Excellent welding of the elastin biomaterial to porcine aorta is noted with no detectable thermal or other injury to the biomaterial or aorta.

Example 5 Preparation of Elastin-Based Biomaterial & Fusion to Porcine Aorta

Materials: Bovine ligamentum nuchae elastin, Fibrinogen from porcine plasma, and acid soluble type I collagen from rat tail tendon were obtained from Sigma Chemical Corp. (St. Louis, MS.). Elastin was solubilized in 1M KOL/80% ethanol at 50°C for 2.5 hrs. (Hornbreck). Cryoprecipitates were obtained from porcine plasma according to the method of Pool and Shannon (Pool and Shannon). Fresh porcine aorta was obtained from Carlton Packaging Co. (Carlton, Ore) and stored at -20°C until thawed for use.

Elastin-fibrin biomaterials was prepared similarly to methods developed by Rabaud (Rabaud). Patches made of solubilized elastin and cryoprecipitates were prepared

by successive addition with thorough mixing of 200mg.
soluble elastin dissolved in 2 ml buffer, 160 mg.
lyophilized cryoprecipitate dissolved in 1 ml buffer, 2
mg type I collagen dissolved in 0.6 ml buffer, and 0.2
5 ml thiourea solution (0.5 mg/ml H₂O). 6 units of
thrombin were added to 0.5 ml. aliquots of the mixture,
thoroughly mixed in a 1 ml syringe, and injected into
4cm² glass molds. The molds were incubated at 37°C for
30 min. and subjected to 25 mrad of ofg-radiation
10 (cobalt source». The biomaterial was stored at 4°C in
33% EtOH. Prior to use the biomaterial was washed
several times with saline.

Patches were also made with insoluble elastin and
fibrinogen. Lyophilized elastin from Sigma was passed
15 through a U.S. no 4000 mesh sieve (Tyler) prior to use.
Only the 40 μ m or smaller particles were used. 28-0mg
of the filtered elastin was swollen and washed
overnight in an excess of phosphate buffer. the mixture
was centrifuged (1000 rpm, 10 min) and the excess
20 buffer discarded. The swollen elastin was suspended in
2 ml of phosphate buffer. Successively added to this
suspension are 67 mg. lyophilized fibrinogen dissolved
in 1 ml buffer, 2 mg type I collagen dissolved in 0.6
ml buffer, and 0.2 ml thiourea solution (0.5 mg/ml
25 H₂O). Finally, 33 units of thrombin were added and the
mixture was thoroughly vortexed and quickly poured into
3 cm x 7 cm molds. The molds were incubated at 37°C
for 30 min. the biomaterial was stored in 4°C in 33%
EtOH. Prior to use the biomaterial was washed several
30 times with saline solution.

The soluble elastin-cryoprecipitated patch was fused to porcine aorta using an Aluminum Gallium Arsenide diode array laser emitting 808 nm continuous wave optical radiation. Fresh porcine aorta was washed in 0.9% NaCl and trimmed into 2 cm² portions.

Indocyanine green (Sigma) in aqueous concentrated of 1 or 5 mg/ml was applied to aorta via a pasteur pipette, left undisturbed for 5 min. and then blotted away. The tissue was then equilibrated in a 0.9% saline solution for 15 minutes to remove any unbound dye. The biomaterial was then applied to the luminal surface of the aorta. the laser beam was directed at the biomaterial surface via a 1 μ m fused silica fiber (Polymicro Technologies Phoenix, Az.) through a glass coverslip as shown in figure 1. the spot size of the laser beam varied between 1-4 mm. The laser output measured from the fiber tip was 1.5 Watts and exposed durations varied from 5 to 4 seconds.

The insoluble elastin-fibrinogen patch was fused to porcine aorta using an Aluminum Gallium Arsenide diode array laser emitting 790-810 nm pulsed optical radiation (Star Medical Technologies). Thawed porcine aorta was prepared and stained with 5mg/ml aqueous ICG solution as previously described for fresh aorta. After applying the biomaterial to the stained luminal surface of the aorta, laser radiation was directed at the biomaterial via a copper coated condenser placed against a glass coverslip. The laser output was set at 2J and 5 msec pulse durations.

Example 6 Preparation of Elastin-Based Biomaterials
and Fusing of Same

Bovine ligamentum nuchae elastin, fibrinogen from porcine plasma, and acid soluble type I collagen from rat tale tendon were obtained from Sigma Chemical Corp. (St. Louis, Mo).

1 mg. indo cyanine green is dissolved in 1 ml of 24% human serum albumin. 67 mg of fibrinogen was dissolved in 1 ml phosphate buffer (@37°C). Just prior to mixing 16.6 units of thrombin are added to the indocyanine green solution. The mixtures were cooled to 4°C. The two mixtures are rapidly mixed and injected, or poured, into a 3 X 7 cm mold and incubated for 30 min. at 37°C.

Lyophilized elastin from Sigma was passed through a U.S. No. 400 mesh sieve (Tyler) prior to use. Only the 40 μ m or smaller particles were used. 210 mg of the filtered elastin was swollen and washed overnight in an excess of phosphate buffer. The mixture was centrifuged (1000 rpm, 10 min.) and the excess buffer discarded. The swollen elastin was suspended in 1.5 ml of phosphate buffer. Successively added to this suspension were 67 mg lyophilized fibrinogen dissolved in 0.75 ml buffer, 2 mg type I collagen dissolved in 0.45 ml buffer, and 0.15 ml thiourea solution (0.5mg/ml H₂O). Finally, 26 units of thrombin were added and the mixture was thoroughly vortexed and quickly poured onto the fibrin matrix doped with indocyanine green in the 3 cm x 7 cm molds. The molds were again incubated at 37°C for 30 minutes. When removed from the mold, the two

layers are inseparable and the preparation yields a single patch.

Example 7. Welding of elastin fibrin biomaterial to porcine intestine

5

10

Fresh porcine intestine was obtained from Carlton Packing Co. (Carlton, OR). The intestine was rinsed with tap water and stored at -20°C in Ziploc freezer bags. Prior to use the intestine is thawed in ambient air and kept on saline soaked gauze to prevent drying out.

15

20

25

30

The elastin fibrin biomaterial prepared as described in Example 4 was fused to porcine intestine using a Aluminum Gallium Arsenide diode array laser (Star Medical Technologies) as follows: Indocyanine green in aqueous concentrations of 5 mg/ml was applied to the serosa of thawed porcine intestine with a pasteur pipette, left undisturbed for 5 minutes and then blotted away with a Kimwipe EXL wipe. Elastin-fibrin biomaterial was cut into 1 X 1 cm patches an excess moisture was blotted away with a Kimwipe EXL wipe. The biomaterial was then positioned on top of the ICG stained serosa of the intestine and a glass microscope coverlip is positioned on top of the biomaterial. A scale was placed underneath the intestine. Laser radiation was directed at the biomaterial via a 4 X 4 mm copper coated condenser placed against the glass coverslip. Laser output was set at 1.99-2.19 joules and 5 msec pulses. During laser exposure, manual force was applied to the glass

coverslip with the condenser. The amount of pressure applied was monitored on the scale placed underneath the intestine. 5 pulses and 500 to 1600 grams of force resulted in successful adhesion of the elastin-fibrin biomaterial to the intestine. Figure XXX (Figure 14 of army grant proposal) is a light microscope slide of elastin fibrin biomaterial welded to porcine intestine (1.99 joules per pulse, 10 pulses, 500g force).

5

10

Example 8: Preparation and welding of coronary vessel digests.

15

20

25

30

Fresh left anterior descending, right main, and circumflex coronary arteries were excised from a porcine heart. Excess fat and thrombus were removed from the excised vessels. The vessels were cut in half and the distal halves were washed in saline and sonicated in 0.5M NaOH for 45 min at 65°C. The distal halves were then removed from the alkali, immersed in 500 ml distilled water for 30 min, and finally immersed in boiling distilled water for another 30 min. The NaOH-sonicated vessels are hereafter referred to as heterografts. The proximal half of the vessels were saved and stored on saline soaked gauze until use. Right main coronary heterografts were welded to right main and left anterior descending arteries with an Aluminum Gallium Arsenide pulsed dioded laser emitting 790-810 nm optical radiation (Star Medical Technologies). 5 mg of indocyanine green (ICG) was dissolved in 1 ml of distilled water. This solution

was then diluted with 4 ml of 25% human serum albumin (HSA) with careful mixing avoiding the formation of excessive air bubbles. The heterografts were coaxed onto a percutaneous transluminal coronary angioplasty balloon measuring 3.0 mm in diameter when inflated. 5
The heterograft covered balloon was inflated to 4 psi and immersed in the ICG-HSA for 5 minutes to stain the heterograft. After removing the heterograft and balloon from the staining solution, the balloon is 10
deflated and inserted into the untreated proximal half of a right main or LAD coronary artery. Following insertion, the balloon is inflated to 8 psi. The inflated balloon/heterograft is placed on a benchtop and a coverslip is placed over the region to be welded. 15
A 4 X 4 mm copper coated condenser is placed against the coverslip. The laser output was set for 2.3 joules of energy and 5 msec pulse durations. After 5 pulses, the balloon is rotated approximately 30 degrees and another region is illuminated with 5 pulses. This 20
procedure is repeated until the entire circumference of the balloon has been illuminated. The balloon is then deflated, leaving behind the heterograft, now fused to the luminal surface of the artery.

All documents cited above are hereby incorporated 25
in their entirety by reference. One skilled in the art will appreciate from a reading of this disclosure that various changes in form and detail can be made without departing from the true scope of the invention.

Claims:

1. A method for producing a biomaterial capable of being fused onto a tissue substrate comprising:

5 providing a layer of biomaterial having a first and second outer major surface; and

applying an energy absorbing material, which is energy absorptive within a predetermined range of light wavelengths, to a selected one of said first and
10 second outer surfaces of the biomaterial in an amount which will cause fusing together of one of said first and second outer surfaces of the biomaterial and an outer surface of said tissue substrate, said energy absorbing material penetrating into the interstices of
15 said biomaterial,

the selected one of said first and second outer surfaces of the biomaterial being capable of fusing together with the outer surface of the tissue substrate by irradiating the energy absorbing material with light
20 energy in a predetermined wavelength range with an intensity sufficient to facilitate said fusing together.

2. The method of claim 1, wherein the step of irradiating the energy absorbing material comprises
25 indirectly irradiating said energy absorbing material by directing the light energy first through the biomaterial or tissue substrate and then to the energy absorbing material.

3. The method of claim 1, wherein said energy absorbing material comprises a biocompatible chromophore.

4. The method of claim 1, wherein said energy absorbing material comprises an energy absorbing dye.

5. The method of claim 1, which further includes the step of substantially dissipating said energy absorbing material when said biomaterial and said tissue substrate are fused together.

6. The method of claim 1, which further includes the step of staining the first or second surface of said biomaterial with said energy absorbing material.

7. The method of claim 1, which further includes the step of applying said energy absorbing material to one of said outer surfaces of said biomaterial by doping a separate elastin layer with an energy absorbing material, and then fusing the doped separate elastin layer to the biomaterial.

8. The method of claim 1, wherein the energy absorbing layer is substantially uniformly applied to a selected one of said first and second outer surfaces of the biomaterial.

9. The method of claim 1, which further includes the step of covering substantially the entire outer surface of the biomaterial with the energy absorbing material.

10. The method of claim 1, which further includes the step of irradiating the energy absorbing material with light energy at a localized temperature

of from about 40 to 600 degrees C. for period of time
sufficient to cause fusing together of one of said
first and second outer surfaces of the biomaterial and
one of said first and second outer surfaces of said
5 tissue substrate.

11. The method of claim 1, which further
includes the step of irradiating the energy absorbing
material with light energy resulting in a localized
temperature at the interface of said biomaterial and
10 said tissue substrate being from about 50 to 100
degrees C. for a sufficient duration to fuse together
one of said first and second outer surfaces of the
biomaterial and said tissue substrate.

12. The method of claim 1, wherein the average
15 thickness of the energy absorbing material which
penetrates into the interstices of the biomaterial is
from about 0.5 to 300 microns.

13. The method of claim 1, which further
includes the step of arranging the magnitude of the
20 wave length, energy level, absorption, and light
intensity during irradiation with light energy of the
energy absorbing material, and the concentration of the
energy absorbing material, so that the localized
temperature at the interface of said first and second
25 outer surfaces of the biomaterial and the tissue
substrate are maintained at from about 40 to 140 °C.,
thereby fusing together the biomaterial and the tissue
substrate.

14. The method of claim 1, wherein the tissue
30 substrate is a live tissue substrate.

15. The method of claim 1, which further includes the step of employing biomaterials for use in replacement or repair of bladders, intestines, tubes, esophagus, ureters, arteries, veins, stomachs, lungs, hearts, colons, skin, or as a cosmetic implantation.

16. The method of claim 1, which further includes the step of forming an biomaterial into a three-dimensional support structure wherein said biomaterial is combined with a stromal support matrix populated with actively growing stromal cells.

17. The method of claim 1, wherein said stromal support matrix comprise fibroblasts.

18. The method of claim 1, which further includes the step of forming a cellular lining of human cells on one of the major surfaces of said biomaterials.

19. The method of claim 1, wherein said cells which are employed to form such a lining are at least one of endothelial cells, epithelial cells and urothelial cells.

20. The method of claim 1, which further includes the step of forming biomaterials based biocompatible inner lining for mechanical human structures to ensure their continued internal use in a human body.

21. The method of claim 20, wherein the biocompatible inner lining is employed in heart valves, heart implants, dialysis equipment, or oxygenator tubing for heart-lung by-pass systems.

22. The method of claim 1, which includes the step of incorporating a drug into said biomaterial thereby decreasing the need for systemic intravenous or oral medications.

5 23. A method for using a biomaterial comprising:

providing a layer of biomaterial having a first and second outer major surface; and

10 applying an energy absorbing material, which is energy absorptive within a predetermined range of light wavelengths, to a selected one of said first and second outer surfaces of the biomaterial in an amount which will cause fusing together of one of said first and second outer surfaces of the biomaterial and an
15 outer surface of said tissue substrate, said energy absorbing material penetrating into the interstices of said biomaterial,

the selected one of said first and second outer surfaces of the biomaterial being capable of fusing
20 together with the outer surface of the tissue substrate by irradiating the energy absorbing material with light energy in a predetermined wavelength range with an intensity sufficient to facilitate said fusing together.

25 24. The method of claim 23, which further includes the step of forming an biomaterial into a three-dimensional support structure wherein said biomaterial are combined with a stromal support matrix populated with actively growing stromal cells.

25. The method of claim 23, wherein said stromal support matrix comprise fibroblasts.

26. The method of claim 23, which further includes the step of forming a cellular lining of human
5 cells on one of the major surfaces of said biomaterial.

27. The method of claim 23, wherein said cells which are employed to form such a lining are at least one of endothelial cells, epithelial cells and urothelial cells.

10 28. The method of claim 23, which further includes the step of forming a biomaterial inner lining for mechanical human structures to ensure their continued internal use in a human body.

15 29. The method of claim 23, wherein the biocompatible inner lining is employed in heart valves, heart implants, dialysis equipment, or oxygenator tubing for heart-lung by-pass systems.

20 30. The method of claim 23, which includes the step of incorporating a drug into said biomaterial thereby decreasing the need for systemic intravenous or oral medications.

31. A method for producing a biomaterial fused onto a tissue substrate comprising:

25 providing a layer of biomaterial having a first and second outer major surface and a tissue substrate having a first and second outer major surface; and

30 applying an energy absorbing material, which is energy absorptive within a predetermined range of light wavelengths, to one of said first and second outer surfaces of the biomaterial in an amount which will

cause fusing together of one of said first and second
outer surfaces of the biomaterial and one of said outer
surface of said tissue substrate, said energy absorbing
material penetrating into the interstices of said
5 biomaterial;

indirectly irradiating the energy absorbing
material by directing the light energy first through
the biomaterial or tissue substrate and then to the
energy absorbing material, said light energy being in
10 said predetermined wavelength range with an intensity
sufficient to fuse together one of said first and
second outer surfaces of the biomaterial and the outer
surface of said tissue substrate; and

fusing together one of said first and second outer
15 surfaces of the biomaterial and the outer surface of
said tissue substrate and substantially dissipating
said energy absorbing material when said biomaterial
and said tissue substrate are fused together.

32. The method of claim 31, wherein the energy
20 absorbing layer is substantially uniformly applied to
at least one of said outer surfaces covering
substantially the entire outer surface of the
biomaterial with the energy absorbing material.

33. The method of claim 31, which further
25 includes the step of irradiating the energy absorbing
material with light energy at a localized temperature
of from about 40 to 140 degrees C. for period of time
sufficient to cause fusing together of one of said

first and second outer surfaces of the biomaterial and one of said first and second outer surfaces of said tissue substrate.

5 34. The method of claim 31, wherein the average thickness of the energy absorbing material which penetrates into the interstices of the biomaterial is from about 0.5 to 300 microns.

35. The method of claim 31, wherein the tissue substrate is a live tissue substrate.

10 36. The method of claim 31, which further includes the step of employing biomaterial for use in replacement or repair of bladders, intestines, tubes, esophagus, ureters, arteries, veins, stomachs, lungs, hearts, colons, skin, or as a cosmetic implantation.

15 37. The method of claim 31, which further includes the step of forming an biomaterial into a three-dimensional support structure wherein said biomaterial is combined with a stromal support matrix populated with actively growing stromal cells.

20 38. The method of claim 31, wherein said stromal support matrix comprise fibroblasts.

39. The method of claim 31, which further includes the step of forming a cellular lining of human cells on one of the major surfaces of said
25 biomateriale.

40. The method of claim 31, wherein said cells which are employed to form such a lining are at least one of endothelial cells, epithelial cells and urothelial cells.

41. The method of claim 31, which further includes the step of forming a biomaterial inner lining for mechanical human structures to ensure their continued internal use in a human body.

5 42. The method of claim 31, wherein the biocompatible inner lining is employed in heart valves, heart implants, dialysis equipment, or oxygenator tubing for heart-lung by-pass systems.

10 43. The method of claim 31, which includes the step of incorporating a drug into said biomaterial thereby decreasing the need for systemic intravenous or oral medications.

44. An biomaterial capable of being fused onto a tissue substrate comprising:

15 a layer of biomaterial having a first and second outer major surface; and

20 an energy absorbing material, which is energy absorptive within a predetermined range of light wavelengths, applied to a selected one of said first and second outer surfaces of the biomaterial in an amount which will cause fusing together of one of said first and second outer surfaces of the biomaterial and an outer surface of said tissue substrate, said energy absorbing material penetrating into the interstices of
25 said biomaterial,

30 the selected one of said first and second outer surfaces of the biomaterial being capable of fusing together with the outer surface of the tissue substrate by irradiating the energy absorbing material with light energy in a predetermined wavelength range with an

intensity sufficient to facilitate said fusing together.

5 45. The biomaterial of claim 44, wherein the energy absorbing layer is substantially uniformly applied to at least one of said outer surfaces covering substantially the entire outer surface of the biomaterial with the energy absorbing material.

10 46. The biomaterial of claim 44, which further includes the step of irradiating the energy absorbing material with light energy at a localized temperature of from about 40 to 140 degrees C. for period of time sufficient to cause fusing together of one of said first and second outer surfaces of the biomaterial and one of said first and second outer surfaces of said tissue substrate.

15 47. The biomaterial of claim 44, wherein the average thickness of the energy absorbing material which penetrates into the interstices of the biomaterial is from about 0.5 to 300 microns.

20 48. The biomaterial of claim 44, wherein the tissue substrate is a live tissue substrate.

25 49. The biomaterial of claim 44, which further includes the step of employing biomaterial for use in replacement or repair of bladders, intestines, tubes, esophagus, ureters, arteries, veins, stomachs, lungs, hearts, colons, skin, or as a cosmetic implantation.

30 50. The biomaterial of claim 44, which further includes the step of forming an biomaterial into a three-dimensional support structure wherein said

biomaterial is combined with a stromal support matrix populated with actively growing stromal cells.

51. The biomaterial of claim 44, wherein said stromal support matrix comprise fibroblasts.

5 52. The biomaterial of claim 44, which further includes the step of forming a cellular lining of human cells on one of the major surfaces of said biomaterial.

10 53. The biomaterial of claim 44, wherein said cells which are employed to form such a lining are at least one of endothelial cells, epithelial cells and urothelial cells.

15 54. The biomaterial of claim 44, which further includes the step of forming a biomaterial inner lining for mechanical human structures to ensure their continued internal use in a human body.

20 55. The biomaterial of claim 44, wherein the biocompatible inner lining is employed in heart valves, heart implants, dialysis equipment, or oxygenator tubing for heart-lung by-pass systems.

20 56. The biomaterial of claim 44, which includes the step of incorporating a drug into said biomaterial thereby decreasing the need for systemic intravenous or oral medications.

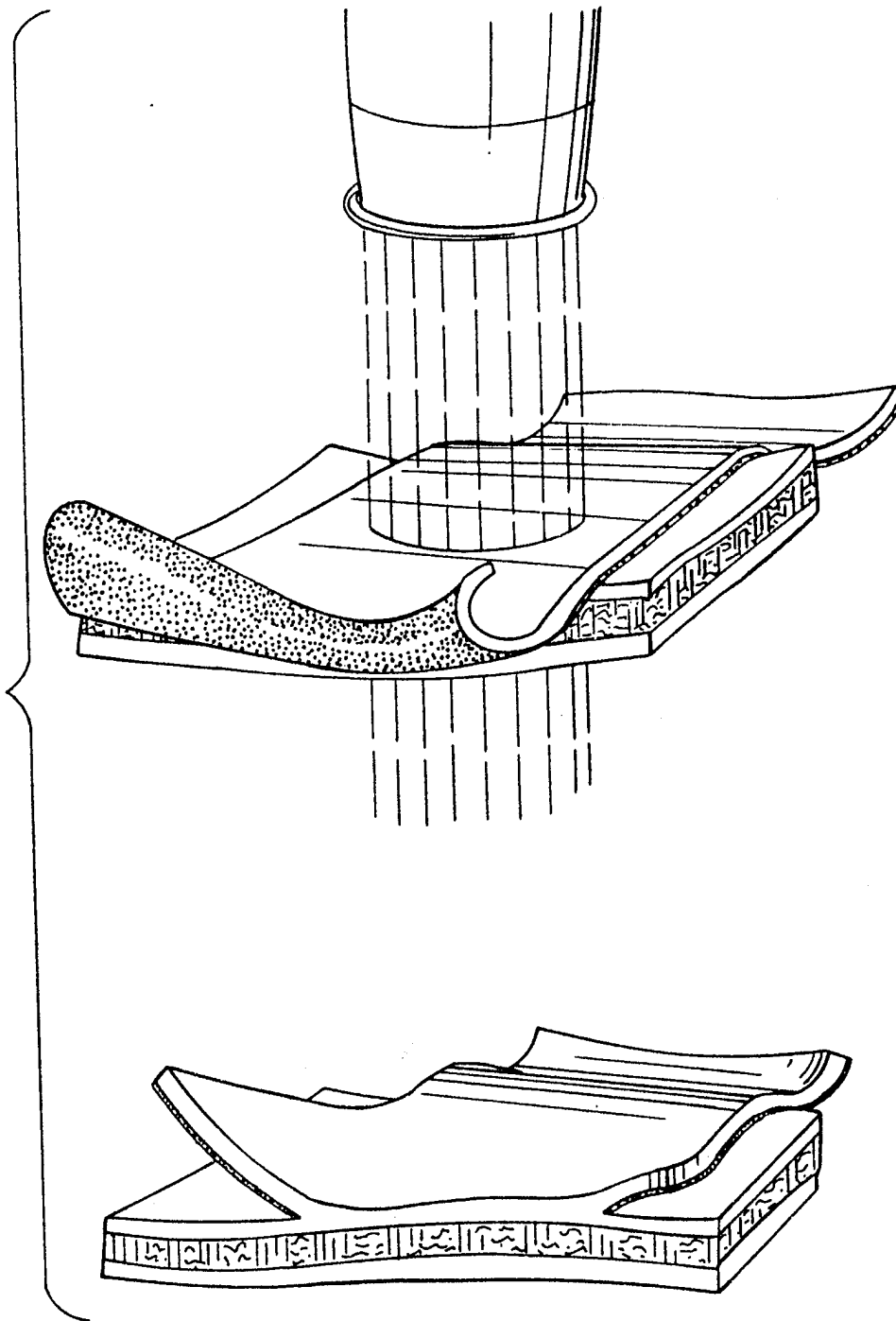

FIG. 1

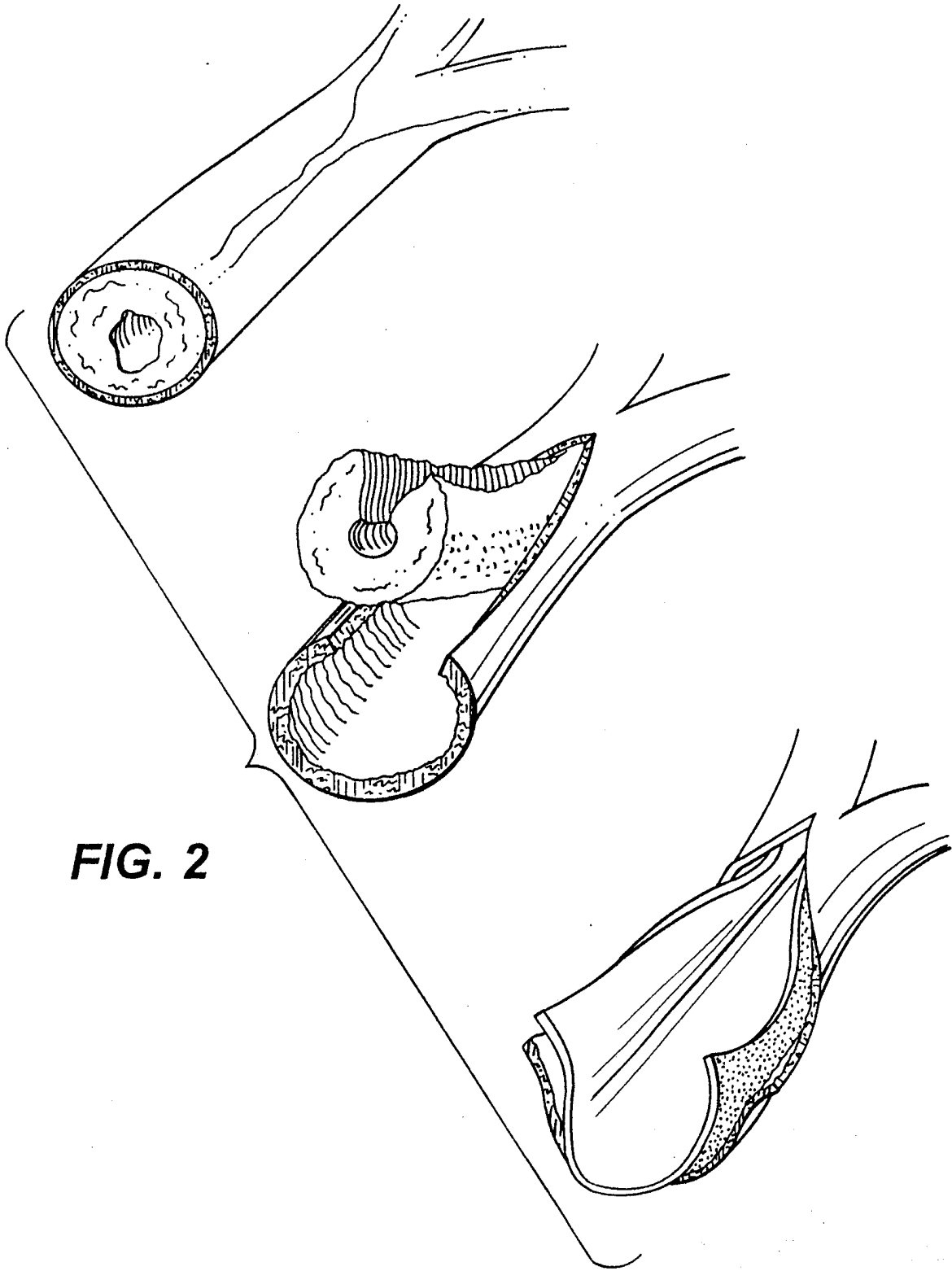

FIG. 2

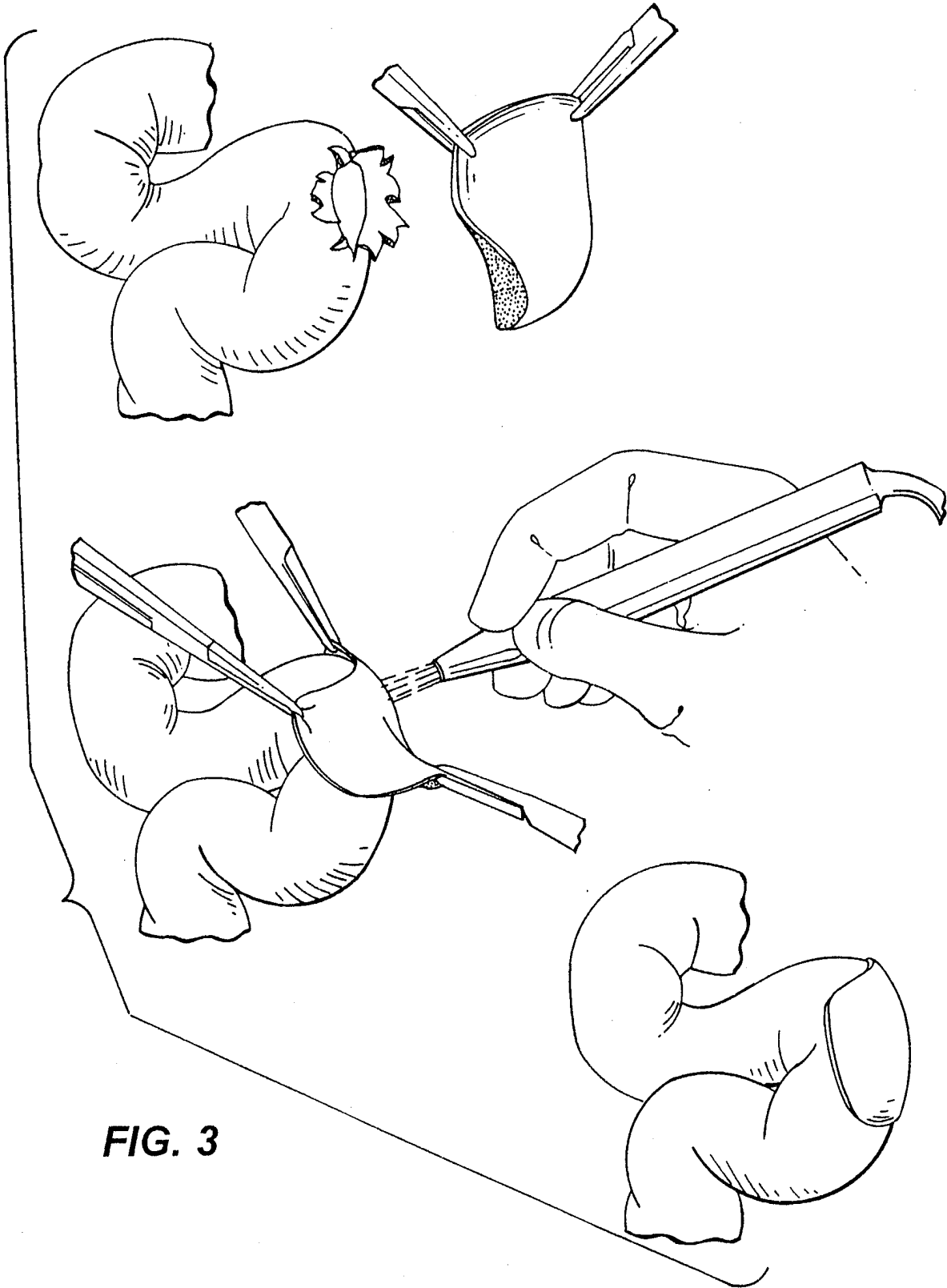

FIG. 3

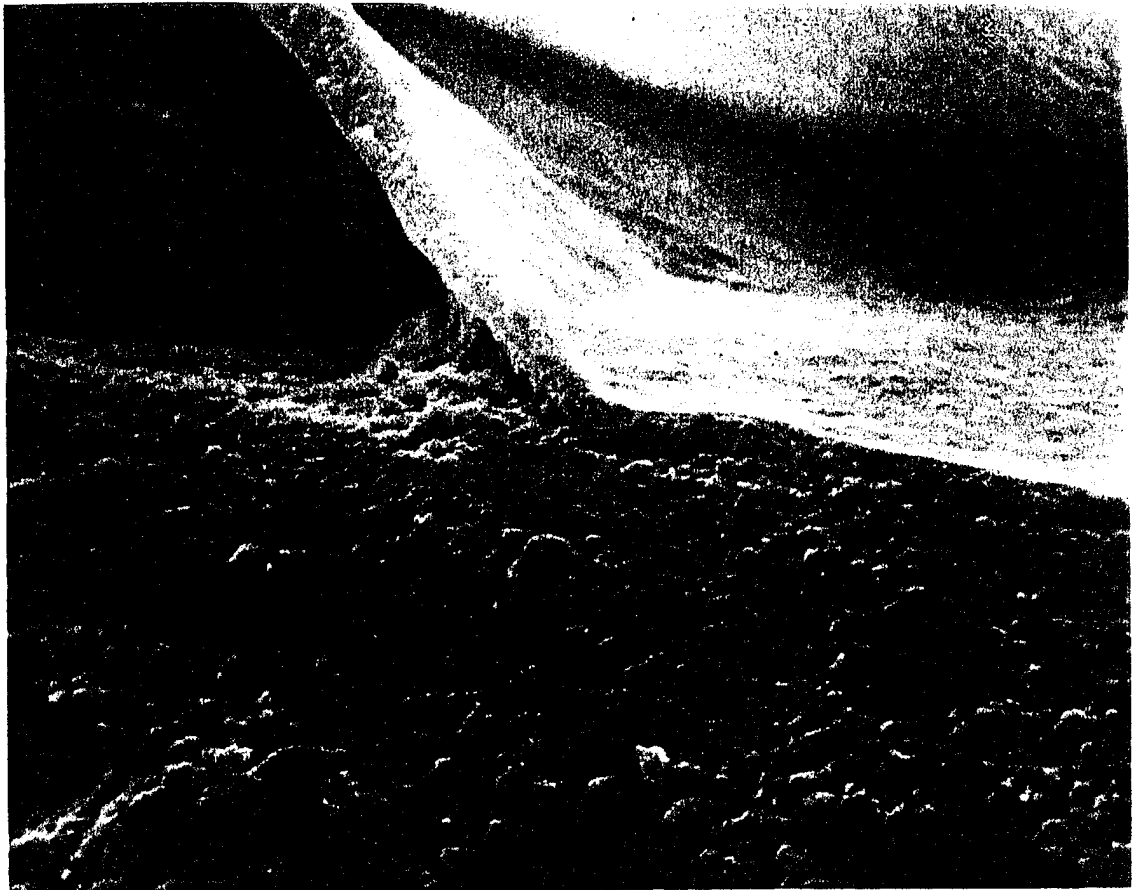

FIG. 4

FIG. 5



FIG. 6



INTERNATIONAL SEARCH REPORT

International application No.
PCT/US98/02243

A. CLASSIFICATION OF SUBJECT MATTER
 IPC(6) :A61F 2/02
 US CL :623/11
 According to International Patent Classification (IPC) or to both national classification and IPC

B. FIELDS SEARCHED
 Minimum documentation searched (classification system followed by classification symbols)
 U.S. : 602/42, 43, 45, 46; 623/1, 11, 12, 15

Documentation searched other than minimum documentation to the extent that such documents are included in the fields searched

Electronic data base consulted during the international search (name of data base and, where practicable, search terms used)
 APS, DIALOG, MEDLINE
 Search Terms: elastin, icg, laser

C. DOCUMENTS CONSIDERED TO BE RELEVANT

Category*	Citation of document, with indication, where appropriate, of the relevant passages	Relevant to claim No.
Y, P	US 5,690,675 A (SAWYER et al) 25 November 1997, col. 2 lines 41-45, line 59, and line 64; col. 6 lines 27-30, lines 40-47; col. 3 line 33; and col. 4 lines 20+.	1-56
Y	US 5,209,776 A (BASS et al) 11 May 1993, col. 4 line 39.	1-56
Y, E	US 5,716,394 A (BRUCHMAN et al) 10 February 1998, claims 1 and 2, and col. 6 lines 58-61.	16-18, 20, 21, 24-26, 28, 29, 37-39, 41, 42, 50-52, 54, 55.

Further documents are listed in the continuation of Box C. See patent family annex.

* Special categories of cited documents:	"T" later document published after the international filing date or priority date and not in conflict with the application but cited to understand the principle or theory underlying the invention
"A" document defining the general state of the art which is not considered to be of particular relevance	"X" document of particular relevance; the claimed invention cannot be considered novel or cannot be considered to involve an inventive step when the document is taken alone
"E" earlier document published on or after the international filing date	"Y" document of particular relevance; the claimed invention cannot be considered to involve an inventive step when the document is combined with one or more other such documents, such combination being obvious to a person skilled in the art
"L" document which may throw doubts on priority claim(s) or which is cited to establish the publication date of another citation or other special reason (as specified)	"&" document member of the same patent family
"O" document referring to an oral disclosure, use, exhibition or other means	
"P" document published prior to the international filing date but later than the priority date claimed	

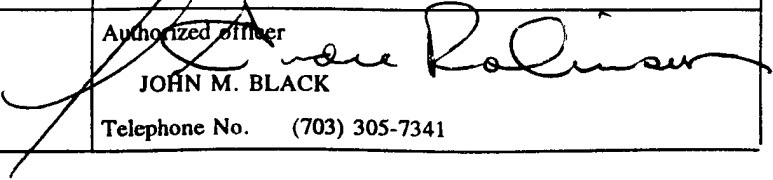
Date of the actual completion of the international search 06 JULY 1998	Date of mailing of the international search report 27 JUL 1998
Name and mailing address of the ISA/US Commissioner of Patents and Trademarks Box PCT Washington, D.C. 20231 Facsimile No. (703) 305-3230	Authorized officer  JOHN M. BLACK Telephone No. (703) 305-7341

INTERNATIONAL SEARCH REPORT

International application No.
PCT/US98/02243

C (Continuation). DOCUMENTS CONSIDERED TO BE RELEVANT

Category*	Citation of document, with indication, where appropriate, of the relevant passages	Relevant to claim No.
Y, P /	US 5,643,712 A (BRASILE) 01 July 1997, col. 4 lines 21-30 and 51-62.	16, 18-21, 27, 28, 37, 39-42, 50, 52-55
A, E	US 5,749,895 A (SAWYER et al) 12 May 1998.	1-56
A, P	US 5,669,934 A (SAWYER et al) 23 September 1997.	1-56
A	KIRSCH et al. Laser Welding Versus Suturing in Tunica Vaginalis and Venous Patch Graft Corporoplasty. The Journal of Urology, Vol. 154, pages 854-857, August 1995.	1-56
A	WANG et al., Endoscopic Diode Laser Welding of Mucosal Grafts on the Larynx: A New Technique, Laryngoscope, Vol 105 No. 1, January 1995, pages 49-52.	1-56