

(19) World Intellectual Property Organization
International Bureau



(43) International Publication Date
19 July 2001 (19.07.2001)

PCT

(10) International Publication Number
WO 01/52125 A1

(51) International Patent Classification⁷: G06F 17/60, G07F 7/00, 17/16

(21) International Application Number: PCT/GB01/00135

(22) International Filing Date: 12 January 2001 (12.01.2001)

(25) Filing Language: English

(26) Publication Language: English

(30) Priority Data: 09/483,079 14 January 2000 (14.01.2000) US

(71) Applicant: MARCONI COMMERCE SYSTEMS LTD.
[GB/GB]; Crompton Close, Basildon, Essex SS14 3BA (GB).

(72) Inventors: QUARENDON, Brian, L.; Buttsmead, Butts Farm Lane, Bishops Waltham, Hampshire SO32 1PE (GB).
TERRANOVA, Steven, N.; 110 Schaffer Close, Cary, NC 27511 (US).

(74) Agent: FITCHETT, Stuart, Paul; Marconi Intellectual Property, Waterhouse Lane, Chelmsford, Essex CM1 2QX (GB).

(81) Designated States (*national*): AE, AG, AL, AM, AT, AU, AZ, BA, BB, BG, BR, BY, BZ, CA, CH, CN, CR, CU, CZ, DE, DK, DM, DZ, EE, ES, FI, GB, GD, GE, GH, GM, HR, HU, ID, IL, IN, IS, JP, KE, KG, KP, KR, KZ, LC, LK, LR, LS, LT, LU, LV, MA, MD, MG, MK, MN, MW, MX, MZ, NO, NZ, PL, PT, RO, RU, SD, SE, SG, SI, SK, SL, TJ, TM, TR, TT, TZ, UA, UG, UZ, VN, YU, ZA, ZW.

(84) Designated States (*regional*): ARIPO patent (GH, GM, KE, LS, MW, MZ, SD, SL, SZ, TZ, UG, ZW), Eurasian patent (AM, AZ, BY, KG, KZ, MD, RU, TJ, TM), European patent (AT, BE, CH, CY, DE, DK, ES, FI, FR, GB, GR, IE, IT, LU, MC, NL, PT, SE, TR), OAPI patent (BF, BJ, CF, CG, CI, CM, GA, GN, GW, ML, MR, NE, SN, TD, TG).

Published:

- with international search report
- before the expiration of the time limit for amending the claims and to be republished in the event of receipt of amendments

For two-letter codes and other abbreviations, refer to the "Guidance Notes on Codes and Abbreviations" appearing at the beginning of each regular issue of the PCT Gazette.

(54) Title: A DATA RETAIL SYSTEM

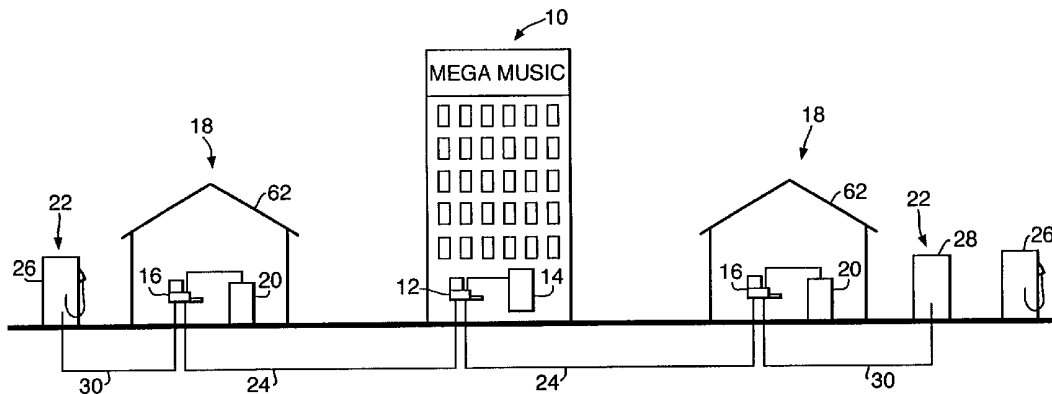

(57) Abstract: A system for retailing music in a fuelling environment (18) includes a central server (12) communicatively connected to a local server (16) in the fuelling environment. The central server (12) downloads music for purchase to the local server (16). The local server communicates to fuel dispensers (26), or music kiosks (28), in the fuelling environment. Consumers may purchase music from the music dispensers as part of a fuelling transaction. The music may be provided to the consumer wirelessly or through a portable data storage device.



WO 01/52125 A1

A DATA RETAIL SYSTEM

The present invention is directed to a system and method enabling the retail of data files and is particularly, but not exclusively, applicable to the retailing of audio files in a fuel dispensing environment.

MP3 and similar digital audio file formats, such as WMA (Windows Media Audio), are becoming popular for use with or through a computer. Portable MP3 players are now available and although the most recent MP3 devices seem to be limited to hand held units, it is expected that devices adapted to be played through a vehicle stereo system will emerge in due course.

Presently, audio file formats such as MP3 are primarily intended for use through a computer, but portable storage media are also emerging as evidenced by SONY's announcement of its "MAGIC GATE MEMORY STICK" for use in its MS WALKMAN. Additionally, the presently preferred method to retail this music is through a computer, perhaps over the Internet, but it is to be expected that consumers, especially the computer illiterate, will demand alternative retail possibilities while preserving the features that make audio files attractive.

According to a first aspect of the present invention there is provided a data retail system comprising:

- (a) a data store suitable for storing data files

- (b) a customer interface adapted to permit a customer to select and purchase a specific data file
- (c) means for down loading, in response to a customer selection, the selected data file to data storage means associated with the customer

According to a second aspect of the present invention there is provided a method of retailing music for use in a vehicle during a fuelling transaction, said method comprising:

displaying a plurality of music selections for purchase at a fuel dispenser interface;
receiving a customer selection for at least one of said plurality of music selections at the fuel dispenser interface;

delivering fuel to a vehicle;

accounting for the purchase of fuel delivered to the vehicle and the customer selection for at least one of said plurality of music selections; and

providing at least one music selection corresponding to the customer selection in a digital format that is conducive for subsequent playback in the vehicle.

The present invention stems from the realisation that modern fuel dispenser typically have associated with them a large data handling capability, some dispensers providing internet access and payment means in the form of credit/debit card acceptors. Thus fuel dispensers, it has been realised, may provide a particularly advantageous if not somewhat non-conventional means to purchase music in the form of audio files. Fuel dispensers are of course by their nature, already provided at locations to which cars have easy access and also have payment means associated with them, if not integrally then at a kiosk.

Modern service stations are provided with a local server, or comparable computer, within the fuelling environment. The local server can be accessible to computers located within the individual fuel dispensers within the fuelling environment, or to other music vending kiosks within the fuelling environment. A consumer may indicate through a user interface on the fuel dispenser or kiosk that they wish to purchase a selected audio file present within the memory of the local server.

Purchase of an audio file or "music transaction" may be incorporated into the fuelling transaction, and payment includes both costs, or the music transaction can be kept distinct from the fuelling transaction, requiring a second payment authorisation from a credit card, separate insertion of cash into a cash acceptor, or the like.

The consumer may insert a portable storage medium into a music dispenser, which could be the fuel dispenser or separate kiosk, and have music downloaded to the portable storage medium. The portable storage medium may then be played by or uploaded into an appropriate device such as an in-vehicle device audio system.

In an alternative arrangement the consumer, or the consumers vehicle, may possess a device including at least a receiver, and the music dispensers include at least a transmitter. The transmitter may transmit the purchased music selection to the receiver, which may then the transmission in an appropriate memory device, either portable or fixed. The memory device could, for example, be a smart card type device, magnetic storage medium,

optical storage medium, a portable MP3 player, an in-vehicle stereo system with associated memory.

Employing a wireless transmitter may enable an in-vehicle computer to allow the consumer to purchase the music without ever getting out of the vehicle. This may be particularly advantageous in a robotic fuelling environment.

The music may be purchased at a first location and then received or downloaded at a second location. This multistage transaction may reduce queues at fuel dispensers or allow a consumer to efficiently download multiple songs while completing multiple transactions. Further, the initial order may be initiated when the consumer is not even physically present within the fuelling environment, but rather while the consumer is driving towards the fuelling environment.

The local server or equivalent computer may be periodically updated to make sure that the songs available are the songs that are most likely to be sold, thereby attempting to maximise revenue generation from the endeavour. Songs that are not being sold may be deleted as needed to make room in the memory for the new songs. To this end a central server may be communicatively connected to a plurality of local servers and act as a central repository for all the music available through the fuelling environments. Additionally, it is possible that the music be stored at the central server, or other remote computer and downloaded directly to the music dispenser.

Various embodiments of the present invention are described below, by way of example only, with reference to the accompanying figures, of which:

Figure 1 is a simplified drawing of a network used to supply music to a fuelling environment;

Figure 2 is a block diagram of a system to provide music from the local server to a music dispenser;

Figure 3 is a simplified drawing of a first technique to transfer music to an in-vehicle device;

Figure 4 is a simplified drawing of a second technique to transfer music to an in-vehicle device;

Figure 5 is a simplified drawing of a third technique to transfer music to an in-vehicle device;

Figure 6 is a schematic drawing illustrating multi-stage purchasing; and

Figure 7 is a schematic drawing illustrating the different aspects of the present invention.

Referring to Figure 1, a central music repository 10 includes a central server 12 and a music memory unit 14. Central server 12 is communicatively coupled to a plurality of local servers 16, each located at different ones of a plurality fuelling environments 18.

Each local server 16 includes a memory device 20 and is communicatively coupled to at least one music dispenser 22.

In practice, the central music repository 10 is likely to be a copyright holding company such as ASCAP, BMI, or a licensee thereof. The music memory unit 14 may be

able to accommodate extremely large volumes of data, preferably in the terabyte category, and may additionally be expandable as needed to accommodate future music storage. Central server 12 may be connected to local servers 16 by the Internet, a Wide Area Network (WAN), a wireless network or the like. For simplicity, the connection will be referred to as network 24. Network 24 may be a dedicated network conveying only information of interest to the present invention, a proprietary network, such as might carry information from a corporate headquarters to a plurality of franchisees, or a common network such as the Internet as needed or desired.

The local server 16 is preferably a computer and may be a site controller, such as the G-SITE, sold by assignee of the present invention, or other comparable computer based server. The memory device 20 preferably accommodates approximately ten to twenty gigabytes of information, but may be expanded as needed or desired. As memory continues to become more affordable, it is expected that this value will become larger. Additionally, memory 20, while shown external to the local server 16, may in fact be incorporated into local server 16 if needed or desired to conserve space.

The music dispensers 22 may be positioned in the fuelling environment 18 forecourt, or they may be associated with a particular building within the fuelling environment 18. For example, the music dispenser 22 may be integrated into a fuel dispenser 26, an independent kiosk 28, a customer user interface associated with a quick serve restaurant, a customer user interface associated with a car wash unit, a customer user interface associated with a convenience store, or the like as needed or desired.

As would be expected, appropriate software to run the various computers, provide the appropriate communications and otherwise support the present invention may be installed on the appropriate computers. "Servers" are herein defined to be synonymous with the term computers. Likewise, a database in a memory unit that is accessed by remote computers is also to be included in the term server or computer. Still further, a distributed computer that has a central memory on which the music is stored should also be considered a server.

As shown in Figure 1, the music dispensers 22 are connected by fixed lines 30 to local servers 16. However, it should be appreciated that the lines 30 may be a wireless communications system 32, and network 24 may also be wireless as shown in Figure 2. This substitution requires the addition of the appropriate transmitters and receivers. Additionally, since the data transferred in the present invention is presently typically on the order of fifty Mbytes for a typical MP3 file, broadband communications are desirable.

With these or equivalent communications systems in place, it is possible to vend music to a consumer in the fuelling environment 18, as better seen in Figure 3. Specifically, the music dispenser 22 includes a local controller 34 located within a housing 36. In the event that the music dispenser 22 is a fuel dispenser 26, the local controller 34 may be integrated into the control system of the fuel dispenser 26 and also act to authorise fuelling transactions, fuel grade selection, vapour recovery, and the like. Music dispenser 22 may include a display 38 and a keypad 40. Equivalently, the display 38 and keypad 40 may be replaced by a touchscreen or the like as needed or desired. Additionally, the music dispenser 22 may include an RF transmitter 42 and a disk drive 44. While labelled a

transmitter, transmitter 42 could equivalently be a full transceiver with transmit and receive capabilities. Additionally, it is possible that the local controller 34 includes sufficient memory therein to store music without resort to memory device 20.

A customer may have a portable playback device 46 with receiver capabilities, or perhaps even transceiver capabilities that communicates with the transmitter 42. Portable playback device 46 may, for example, be an MP3 player, a smart card, some other music player with a built in memory unit for recording thereon, or a music player with memory for downloading thereto. Alternatively, the customer may have a portable storage medium 48, such as a minidisk, a flash memory card, an IOMEGA click disk, a CDR, the like or equivalent, which may be inserted into disk drive 44 and is fully compatible therewith. Still further, the portable storage medium 48 may be generated within the music dispenser 22 on an as needed basis. Media 48 may be disposable or not as needed or desired.

Additionally, the transmitter 42 may communicate directly to a vehicle 50, specifically through an antenna 52, as better seen in Figure 4. Antenna 52 is communicatively coupled to an in-vehicle playback device 54 with associated memory 56. In-vehicle playback device 54 further may include a disk drive 58 that accommodates the portable storage medium 48 previously described. The portable playback device 46 may communicate with or be installed into the in-vehicle playback device 54. In-vehicle playback device 54 is preferably wired into the stereo system of the vehicle 50 and may serve multiple duties, such as radio, CD player, tape player, MP3 player or other audio format player as needed or desired. Thus, if the portable playback device 46 has

downloaded music from the music dispenser 22, it may be reinstalled into the car stereo system and play as normal until needed for a future download or the like.

Further, an antenna 60 on the fuelling station building 62 may broadcast to the antenna 52 on the vehicle 50, as shown in Figure 5. Antenna 60 communicates with playback device 54 and stores received music files on memory 58.

Still further, as seen in Figure 6, it is possible that the music transaction may be completed from a plurality of locations. Specifically, a vehicle 50 may begin a transaction at a fuel dispenser 26. During the fuelling transaction, the consumer may also arrange for other transactions, such as is disclosed in U.S. Patent 5,956,259, which is hereby incorporated by reference. Payment is authorised for all the transaction and arrangements are made to send the music to the consumer. However, at this time, the fuelling operation is complete, and the consumer is travelling to a second location within the fuelling environment 18 forecourt. For example, if the consumer ordered several songs, the vehicle 50 may move to quick serve restaurant 68 proximate quick serve restaurant music dispenser 70 before the music dispenser in fuel dispenser 26 has finished downloading music to the vehicle 50, the portable device 46 or the storage medium 48.

While the consumer retrieves his food, music dispenser 70 attempts to complete the music transfer and transmits music for recording to the vehicle 50. If the music transfer is still not complete, but the consumer has requested a car wash, the vehicle 50 may then be moved to the car wash 64, proximate car wash music dispenser 66. Car wash music dispenser 66 finishes the music transfer while the car is being washed. In another example,

the vehicle 50A begins the transaction and secures payment authorisation at a fuel dispenser 26, but then receives all the music from a stand alone kiosk 28. Both of these are intended as examples, many variations are possible. It is easier for the consumer to receive the music transfer through the antenna 52, but at each station she could exit the vehicle 50 and use a portable device 46 or 48 with the music dispenser in question.

Additionally, as disclosed in the incorporated application serial number _____, entitled MULTISTAGE DATA PURCHASE, the transaction may be initiated by a consumer in a vehicle in route to a music dispenser. In this event, the information retrieved according to the methodology of that application is music.

With the hardware now fully described, the methodology of the present invention may now be explored with greater ease. Initially, the central server 12 and memory 14 are stocked with music. This may comprise copying CDs into an MP3 format on memory 14, downloading MP3 files to memory 14 from an external source, or the like. While it is assumed that MP3 is the format of choice in terms of compressing the most music into the smallest memory, other existing and future formats may be equally viable and desirable, such as WMA or the like. At some point, a decision will be made that memory 14 and central server 12 are adequately supplied with music files, and they will be made available to the fuelling environments 18.

Once the hardware is in place, a fuelling environment 18 may elect to vend music to its fuelling customers or other individuals who have reason to stop in the fuelling environment 18. Local server 16 may contact via network 24 central server 12 and ask to

download music to the memory 20. In instances where the network 24, or more specifically the central server 12, is accessible from a plurality of computers, both authorised to download and not authorised to download, appropriate security measures may be used to ensure that only authorised servers 16 download music from the central server 12. In the preferred embodiment, to conserve bandwidth, music is transmitted from the central server 12 to the local server 16 at non-peak usage times such as the middle of the night. This is especially true where the network 24 is the Internet. Additionally, since the network 24 may be used for other communications from the fuelling environment 18, conservation of bandwidth is of concern.

Once music is downloaded to the memory 20, it becomes available for purchase through the music dispensers 22. It should be appreciated that music on the memory 20 will become dated, or unpopular, and it may be necessary to update it periodically. New music may be downloaded from the central server 12, again, preferably at non-peak times, and music that is not selling may be deleted, written over, or shuffled off into auxiliary memory. Memory constraints presently suggest that the non-selling music will be deleted, however, if memory continues to become more affordable, this may no longer be an issue, and the music files may accumulate as desired or needed.

Further, the local controller 34 within the music dispenser 22 may contain sufficient memory to store the music files therein. While this is presently not feasible given the economics of memory chips, it is certainly conceivable, and may be preferred at some later date.

Additionally, it is conceivable that when the music dispenser 22 receives a purchase order from a consumer, then at that time the music dispenser 22 retrieves the ordered music from the central server 12. At present this is not preferred because of the demands such data transfers place upon the networks 24 and 30, however, as bandwidth becomes more available for high speed data transfers, such an arrangement may become more feasible.

The actual purchasing and delivery of the music may take a number of different forms. A flow chart of the variants is seen in Figure 7. The first decision is made by the consumer and concerns the type of dispenser 22 that the consumer approaches (block 100). Specifically, the consumer may approach a stand alone kiosk 28 (block 100A) within the fuelling environment 18, or a music dispenser 22 that is integrated into another sales terminal, such as a fuel dispenser 26 (block 100B). This choice is obviously influenced by the needs of the consumer. If the consumer needs to purchase fuel, he is likely to approach a fuel dispenser 26. If the consumer needs to purchase something from a quick serve restaurant or car wash, then the consumer is likely to approach a music dispenser 22 integrated into the sales terminal associated with that particular forecourt feature. If however, the consumer heard a catchy tune on the radio and decided to make an impulse purchase, then the consumer may be likely to head straight to a stand alone kiosk 28.

The nature of the transaction must then be determined (block 102). Namely, the transaction may occur from within the vehicle 50 (block 102A) or external to the vehicle 50 (block 102B). That is, vehicles of the future are likely to have an in-vehicle computer integrated into the vehicle. This computer may control a number of things within the vehicle, but of particular concern is the fact that the computer may be operatively

connected to a transceiver that may in turn be operatively connected to the antenna 52. Through this computer, a consumer may have a user interface that communicates effectively with the music dispenser 22 through the transceiver 42, whether the music dispenser is a dedicated music dispenser 28 or integrated into another device such as fuel dispenser 26. Glimmers of this functionality are starting to be seen in vehicle mounted transponders that automatically interact with fuel dispensers to authorise payment, select fuel grade and the like. The present invention takes this one step further and supports full bi-directional communication between the in-vehicle computer and the music dispenser 22. U.S. Patent No. 5,914,654, which is hereby incorporated by reference, provides a good discussion of the possibilities and requirements of vehicle to external unit communication.

Alternatively, the transaction may be a bit more manual, and the consumer may interact directly with the music dispenser 22 through the display 38 and the keypad 40. This requires that the consumer exit the vehicle. This is not particularly unusual during a fuelling transaction, as the consumer typically has to insert the nozzle into the fuel tank of the vehicle 50 prior to dispensing fuel. Note also robotic fuelling seems just around the corner, and consumers may no longer have to exit the vehicle during a fuelling transaction. In that event, it may be desirable to order music from the vehicle during the fuelling transaction.

The next variant on the invention is the origin of the music transaction (block 104). A consumer may initiate the music purchase (block 104A), or the music dispenser 22 may query the user whether or not he wishes to purchase music at that time (block 104B).

Still another variant is the method of payment (block 106). Payment can be authorised at within the station building 62 (block 106A), the music dispenser 22 (block 106B), or from within the vehicle 50 (block 106C). As would be expected, cash, credit cards, debit cards, transponders, or the like may be used within the station building 62. Likewise, the music dispenser 22 may be equipped with a cash acceptor, a magnetic card reader, a wireless interrogator, or the like to facilitate payment acceptance at the music dispenser 22. In those instances wherein an in-vehicle transaction is occurring, it will be preferable to automate the transmission of payment information to the music dispenser 22, although there is nothing that precludes a person from leaning out his window in the vehicle and interacting with the music dispenser 22 in a fashion similar to an ATM, at least for payment authorisation.

Yet another variant is whether or not the music sale is integrated into another transaction for the purposes of payment (block 108). In those instances wherein the music is purchased from a stand alone music dispenser 28, it makes little sense to integrate the transaction into another transaction, since in all likelihood there is no such transaction in which to perform the integration (block 108A). However, in those instances where the consumer has approached an integrated music dispenser 22 such as within a fuel dispenser 26, there is an opportunity to have only one transaction occur, saving time, bandwidth required to secure external approval and the like (block 108B). Further, the transaction can be multi-stage as described in reference to Figure 6 (block 108C).

The next variant to be determined is how music is delivered from the memory to the consumer (block 110). In particular, music may be delivered to the consumer through

the antenna 60 on the building 62 (block 110A) or through the music dispenser 22 (block 110B). If provided through the music dispenser 22, the music may be broadcast from the antenna 42 or accessed through the disk drive 44. Alternatively, the music may be downloaded over a cellular network. For example, an integrated cellular phone and computer could dial a particular phone number over a cellular network and then download the desired music.

The final variant to be determined is how the consumer receives the music (block 112). Obviously this is somewhat related to how the music was delivered. For example, if the antenna 60 broadcast the music for recording, then it would be difficult to use a portable storage medium 48 to receive the music. However, the portable storage medium 48 (block 112C) could be placed in the disk drive 44 and the music could be downloaded thereto. Alternatively, the device 46 may receive a broadcast from either the antenna 60 or the antenna 42, depending on which antenna is broadcasting (block 112B). Moreover, the antenna 52 may receive the broadcast from antenna 60 or antenna 42 (block 112A). Given that a typical fuelling transaction lasts approximately two minutes, it is desired that the transmission times take on the order of two minutes. Given a typical MP3 file, this is approximately .42 Mbytes/second. Currently, only Bluetooth technology or high speed LAN technology support this rate of data transfer, although other conventions may become available subsequent to this invention. However, multi-stage transactions eliminate some of the concern in this area, because through the use of multi-stage transactions, the vehicles may be moved out of the high traffic areas in front of the fuel dispensers 26 and still achieve music transfers. For example, car washes are substantially longer than fuelling

transactions, so transfer rates at the car wash music dispenser 66 do not necessarily have to be as fast as those at the fuel dispenser 26.

It should be appreciated that aspects of different variants may be combined as needed or desired, and all or some may be present within a particular fuelling environment 18. The present invention may, of course, be carried out in other specific ways than those herein set forth without departing from the spirit and essential characteristics of the invention. The present embodiments are, therefore, to be considered in all respects as illustrative and not restrictive, and all changes coming within the scope of the appended claims are intended to be embraced therein.

CLAIMS

1. A data retail system comprising:
 - (d) a data store (20) suitable for storing data files
 - (e) a customer interface (38, 40) adapted to permit a customer to select and purchase a specific data file
 - (f) means (44) for down loading, in response to a customer selection, the selected data file to data storage means (48) associated with the customer
2. The system of claim 1 adapted to retail and download music in the form of audio files.
3. The system of claim 1 or 2 wherein the data is stored at a location (14) remote from the interface (38, 40) and downloaded to a data dispenser (26) associated with the interface.
4. The system of claim 1 or 2 wherein the data is stored at a data dispenser associated with the interface.
5. The system of any preceding claim arranged to download a data file directly to a memory unit associated with a vehicle (48).
6. The system of any one of claims 1 to 4 arranged to download a data file indirectly to a memory unit associated with a vehicle.

7. The system of any one of claims 1 to 4 or 6 arranged to download a data file to a portable storage medium (48).
8. The system of claim (7) wherein the portable storage medium comprises a computer readable storage medium.
9. The system of claim 5 arranged to download a data file to a playback device (46) associated with a vehicle.
10. The system of any preceding claim comprising a music dispenser (26) in which the customer interface is located and a remote retail terminal (16) wherein data in the form of a music audio file is selected at the music dispenser and at least a portion of the music is received at the retail terminal.
11. The system of claim 10 wherein all the music is received at the retail terminal.
12. The system of any preceding claim comprising a dispenser (26) in which the customer interface is located enabling a customer to purchase data at the dispenser.
13. The system of claim 12 wherein the dispenser (26) downloads data in the form of a music audio file via a radio link (42, 52).

14. The system of claim 12 or 13, except when dependent on claim 11, wherein the dispenser is a fuel dispenser (26) and wherein the dispenser begins downloading the music during an associated fuelling transaction.
15. The system of any one of claims 11 to 13 wherein the dispenser instructs a remote retail terminal (16) to download music.
16. The system of any preceding claim comprising a music dispenser (28) in which the customer interface is located.
17. The system of claim 16 wherein the music dispenser is arranged to be integrated into a fuelling environment (18).
18. The system of claim 17 wherein the music dispenser is associated with a fuel dispenser (26).
19. The system of claim 18 wherein said music dispenser is integrated into a fuel dispenser (26).
20. The music dispenser of claim 17 wherein said music dispenser is associated with a car wash facility (26) within the fuelling environment.
21. The music dispenser of claim 17 wherein said music dispenser is associated with a quick serve restaurant (68) within the fuelling environment.

22. The music dispenser of claim 17 wherein said music dispenser is associated with a retail terminal in a convenience store within the fuelling environment.

23. The system of claim 22 comprising a plurality of fuel dispensers (26), at least one retail terminal and a computer (20) for storing audio files thereon operatively connected to a retail terminal (16), wherein a customer may purchase at least one audio file through the music dispenser.

24. The system of claim 23 wherein the computer is configured to communicate with a central server (12) remote from said fuelling environment (18).

25. The system of any preceding claim wherein a music purchase is integrated with a second retail transaction.

26. The system of any preceding claim wherein a customer may purchase music at a retail terminal and receive said music at a music dispenser at a later time.

27. The system of any preceding claim wherein data in the form of a music audio file is transmitted via a radio signal to a receiver associated with a customer.

28. A fuel dispensing system comprising a system in accordance with any preceding claim for facilitating the purchase of music for playback in a vehicle (50), said system comprising:

a fuel dispenser (26) including:

fuel delivery hardware for delivering fuel to a vehicle from a storage tank;

a user interface (38, 40) for facilitating purchase of fuel delivered to the vehicle and music for playback in the vehicle;

a music datastore containing a plurality of music selections for purchase via the customer interface at said fuel dispenser; and

means (44) for transferring music purchased at said customer interface of said fuel dispenser in a digital format from said music datastore to the vehicle for subsequent playback in the vehicle.

29. Method of retailing music for use in a vehicle during a fuelling transaction, said method comprising:

displaying a plurality of music selections for purchase at a fuel dispenser interface;

receiving a customer selection for at least one of said plurality of music selections at the fuel dispenser interface;

delivering fuel to a vehicle;

accounting for the purchase of fuel delivered to the vehicle and the customer selection for the at least one of said plurality of music selections; and

providing at least one music selection corresponding to the customer selection in a digital format that is conducive for subsequent playback in the vehicle.

30. A data retail system substantially as hereinbefore described with reference to, and/or as illustrated in, one or more of the accompanying figures.

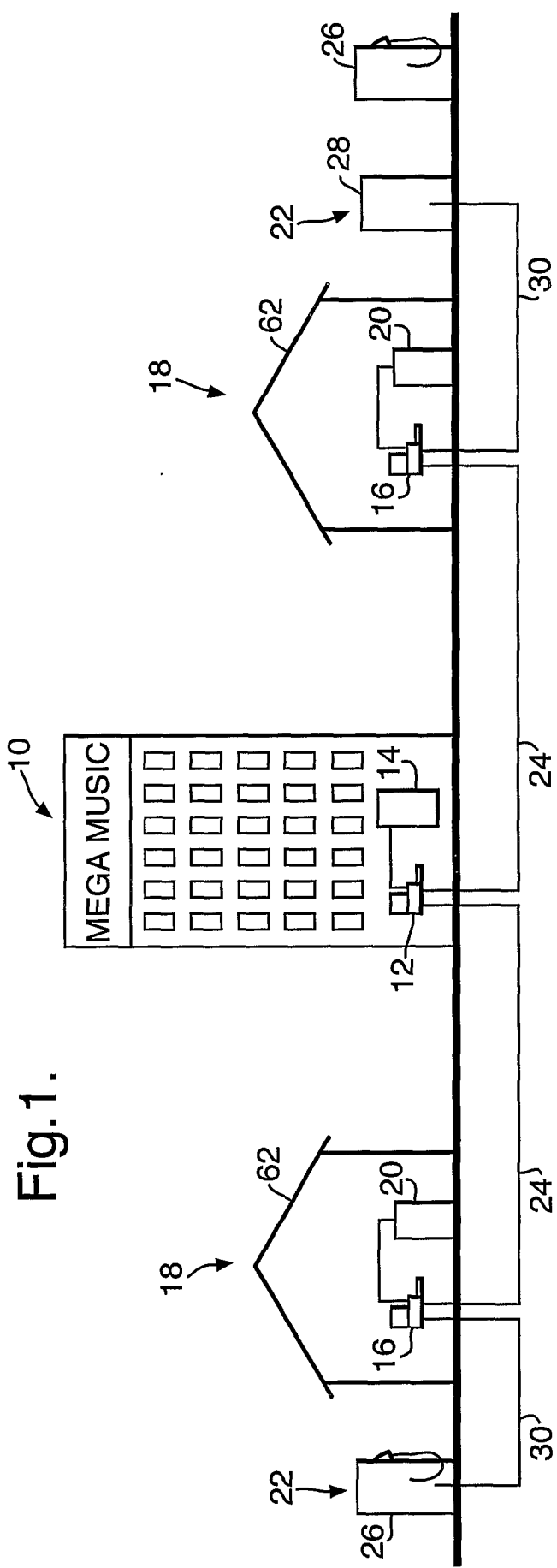

Fig. 1.

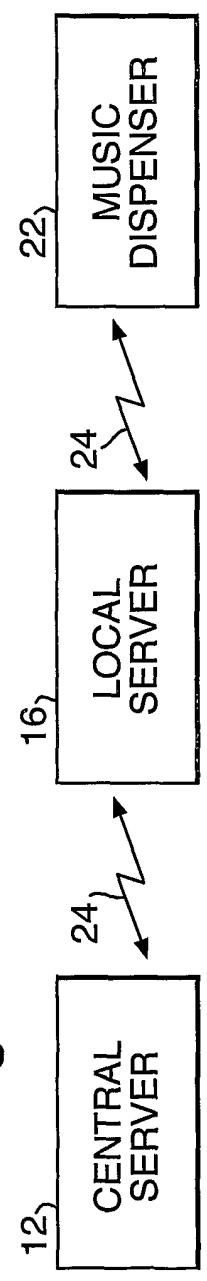

Fig. 2.

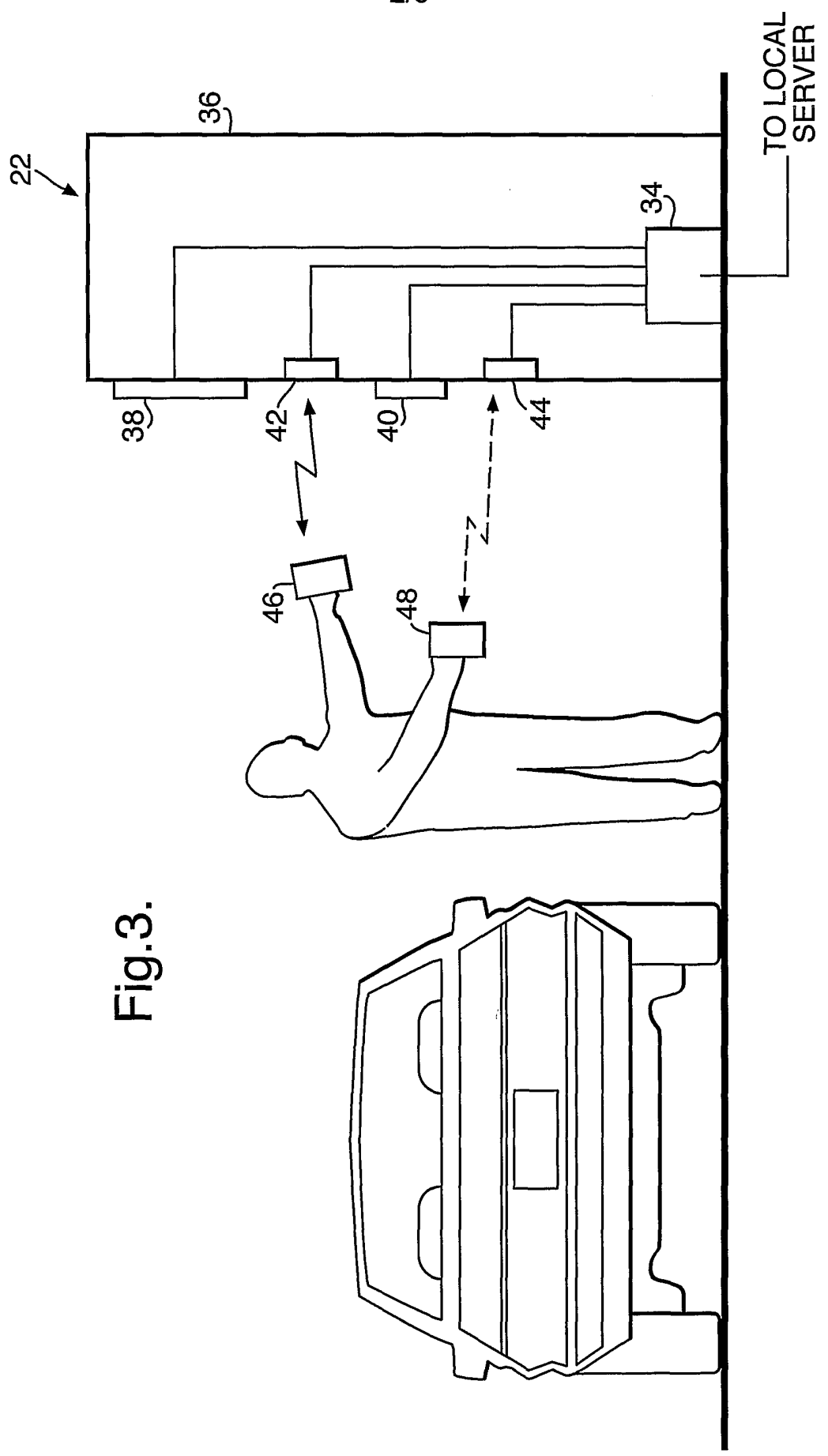

Fig.3.

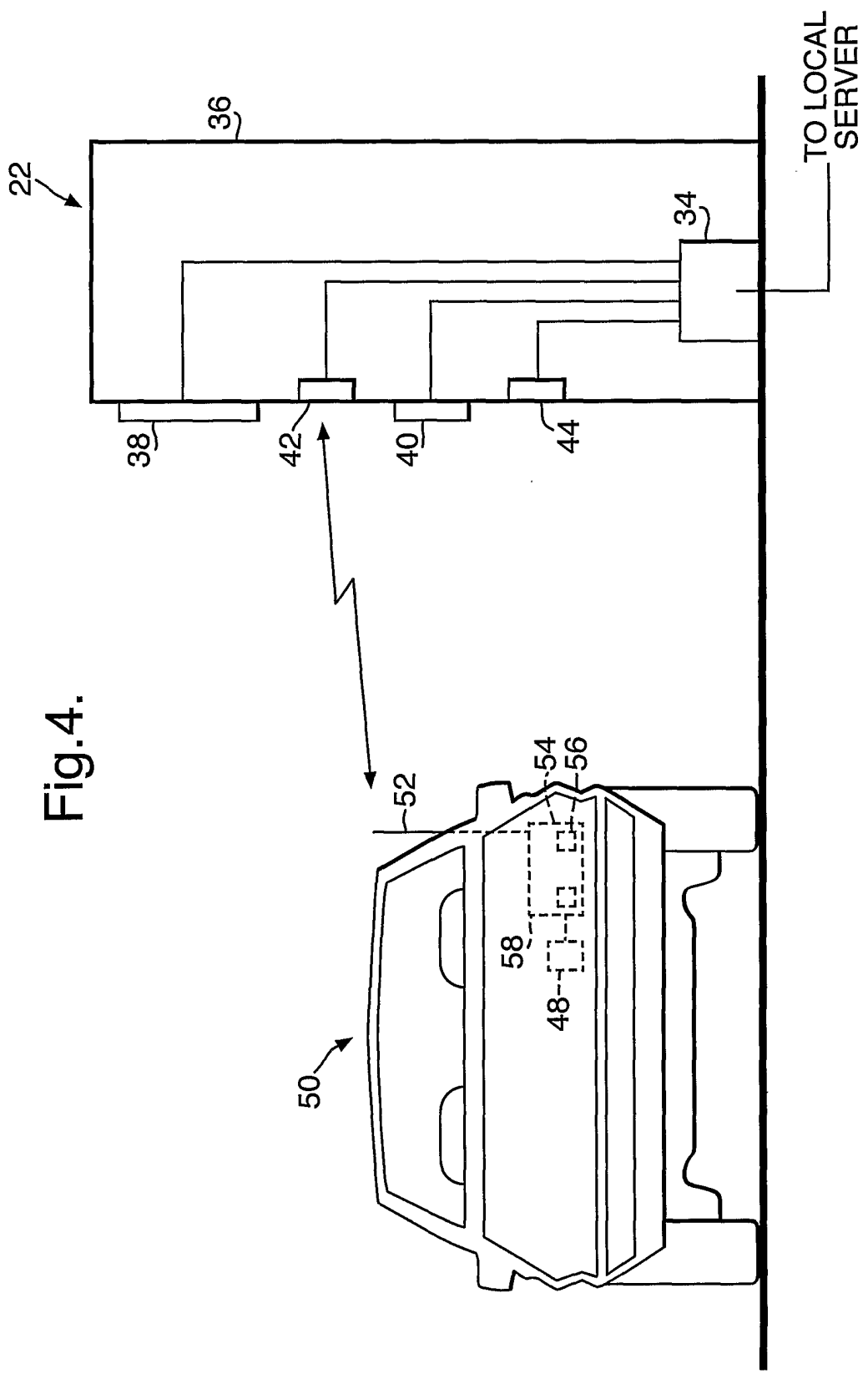

Fig.4.

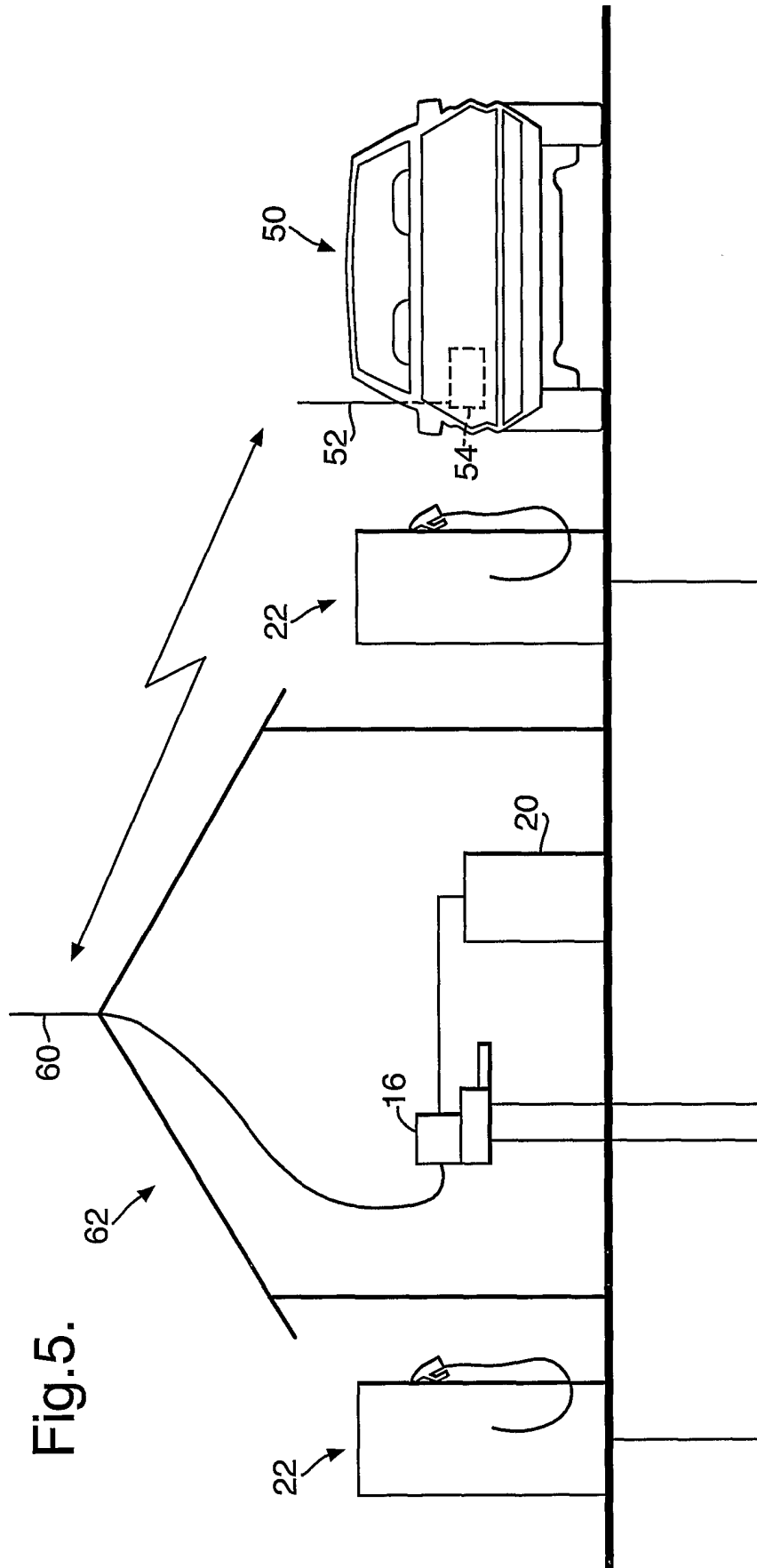

Fig. 5.

Fig.6.

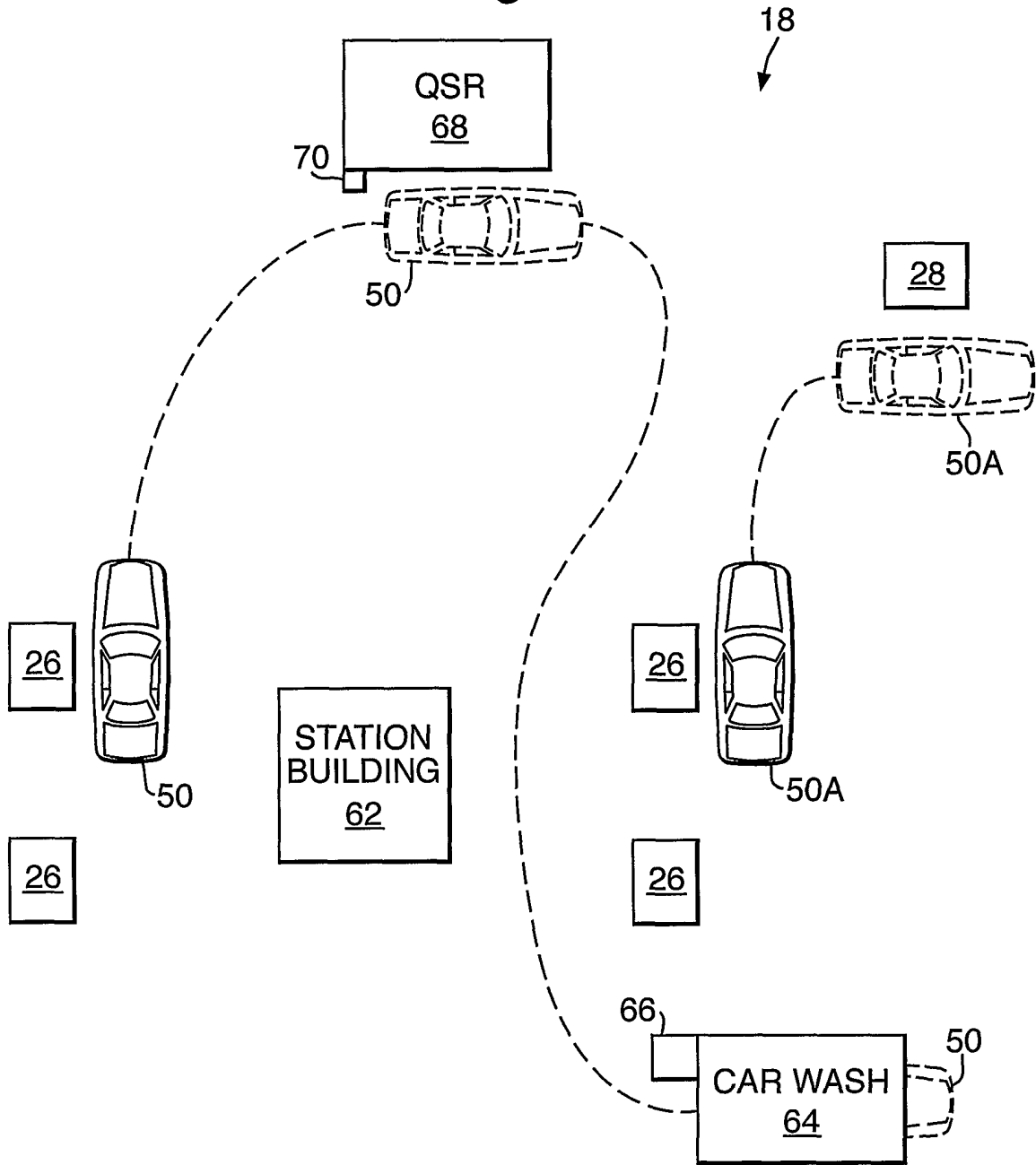
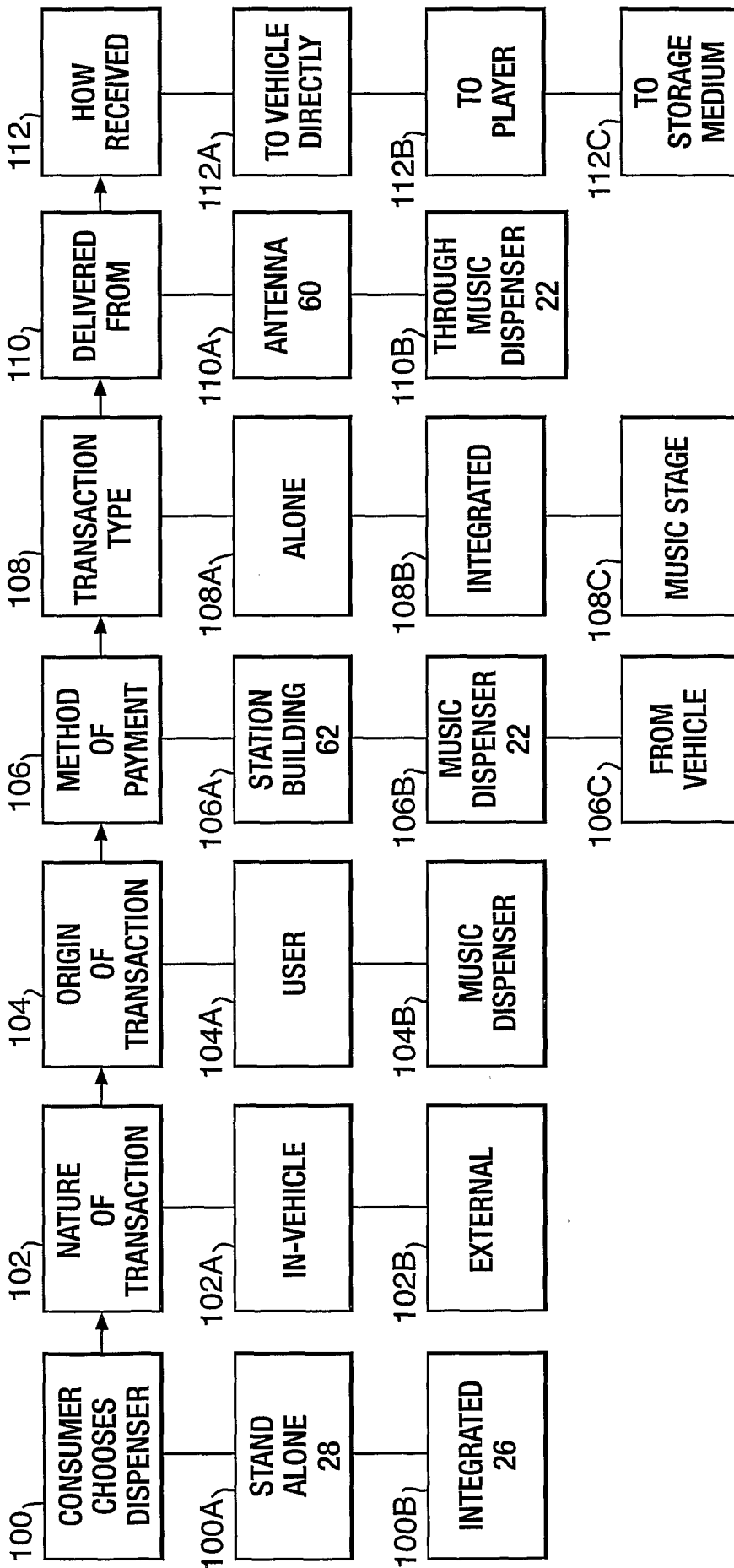

Fig. 7.



INTERNATIONAL SEARCH REPORT

Internat. Application No
PCT/GB 01/00135

A. CLASSIFICATION OF SUBJECT MATTER

IPC 7 G06F17/60 G07F7/00 G07F17/16

According to International Patent Classification (IPC) or to both national classification and IPC

B. FIELDS SEARCHED

Minimum documentation searched (classification system followed by classification symbols)

IPC 7 G06F G07F G10H G11B G01C H04H

Documentation searched other than minimum documentation to the extent that such documents are included in the fields searched

Electronic data base consulted during the international search (name of data base and, where practical, search terms used)

EPO-Internal, WPI Data

C. DOCUMENTS CONSIDERED TO BE RELEVANT

Category °	Citation of document, with indication, where appropriate, of the relevant passages	Relevant to claim No.
X	US 5 636 276 A (BRUGGER ROLF) 3 June 1997 (1997-06-03) abstract; claims 1,4-6; figure 1	1-4,7,8, 30
Y	column 2, line 56 - line 65	5,6,14, 17-22, 26,28,29
X	WO 00 00972 A (YANG JUN MO ;KIM JONG WOO (KR); RYOO SOON SEOP (KR)) 6 January 2000 (2000-01-06) abstract	1,2,7,8, 12,16,30
X	GB 2 332 772 A (SAMSUNG ELECTRONICS CO LTD) 30 June 1999 (1999-06-30)	1,2,30
Y	page 1, line 15 -page 2, line 8 page 3, line 17 -page 4, line 2 claim 1; figure 1	13,27
	-/--	

Further documents are listed in the continuation of box C.

Patent family members are listed in annex.

° Special categories of cited documents :

- *A* document defining the general state of the art which is not considered to be of particular relevance
- *E* earlier document but published on or after the international filing date
- *L* document which may throw doubts on priority claim(s) or which is cited to establish the publication date of another citation or other special reason (as specified)
- *O* document referring to an oral disclosure, use, exhibition or other means
- *P* document published prior to the international filing date but later than the priority date claimed

- *T* later document published after the international filing date or priority date and not in conflict with the application but cited to understand the principle or theory underlying the invention
- *X* document of particular relevance; the claimed invention cannot be considered novel or cannot be considered to involve an inventive step when the document is taken alone
- *Y* document of particular relevance; the claimed invention cannot be considered to involve an inventive step when the document is combined with one or more other such documents, such combination being obvious to a person skilled in the art.
- * & * document member of the same patent family

Date of the actual completion of the international search

15 June 2001

Date of mailing of the international search report

22/06/2001

Name and mailing address of the ISA

European Patent Office, P.B. 5818 Patentlaan 2
NL - 2280 HV Rijswijk
Tel. (+31-70) 340-2040, Tx. 31 651 epo nl,
Fax: (+31-70) 340-3016

Authorized officer

Paraf, E

INTERNATIONAL SEARCH REPORT

International Application No
PCT/GB 01/00135

C.(Continuation) DOCUMENTS CONSIDERED TO BE RELEVANT		
Category *	Citation of document, with indication, where appropriate, of the relevant passages	Relevant to claim No.
Y	<p>WO 99 16700 A (GILBARCO LTD) 8 April 1999 (1999-04-08)</p> <p>page 2, line 30 -page 3, line 49 claims 1-6,13-15; figures 1-3,9</p>	<p>13,14, 17-22, 26-29</p>
Y	<p>US 5 987 381 A (OSHIZAWA HIDEKAZU) 16 November 1999 (1999-11-16) claims 4,7,9,13,14; figures</p>	<p>5,6</p>
A	<p>US 5 790 423 A (KATZ DONALD R ET AL) 4 August 1998 (1998-08-04) claim 1; figures</p>	

INTERNATIONAL SEARCH REPORT
Information on patent family members

International Application No
PCT/GB 01/00135

Patent document cited in search report	Publication date	Patent family member(s)	Publication date
US 5636276 A	03-06-1997	DE 4413451 A	14-12-1995
		AT 169762 T	15-08-1998
		DE 59503112 D	17-09-1998
		DK 678851 T	17-05-1999
		EP 0678851 A	25-10-1995
		ES 2119344 T	01-10-1998
		GR 3027730 T	30-11-1998

WO 0000972 A	06-01-2000	AU 4655799 A	17-01-2000
		CN 1273669 T	15-11-2000

GB 2332772 A	30-06-1999	NONE	

WO 9916700 A	08-04-1999	AU 9179298 A	23-04-1999
		AU 9179698 A	23-04-1999
		AU 9179798 A	23-04-1999
		AU 9356198 A	23-04-1999
		EP 1017615 A	12-07-2000
		EP 1017614 A	12-07-2000
		EP 1017616 A	12-07-2000
		WO 9916701 A	08-04-1999
		WO 9916702 A	08-04-1999
		WO 9916703 A	08-04-1999
		US 6157871 A	05-12-2000
		US 6070156 A	30-05-2000
		US 6098879 A	08-08-2000
		US 6073840 A	13-06-2000
		US 6026868 A	22-02-2000
US 5890520 A	06-04-1999		

US 5987381 A	16-11-1999	CA 2228068 A	11-09-1998
		DE 19808802 A	17-09-1998
		FR 2761788 A	09-10-1998
		GB 2323168 A, B	16-09-1998
		JP 10253377 A	25-09-1998

US 5790423 A	04-08-1998	AU 6278996 A	15-01-1997
		WO 9700484 A	03-01-1997
