



(86) Date de dépôt PCT/PCT Filing Date: 2010/06/24
 (87) Date publication PCT/PCT Publication Date: 2010/12/29
 (85) Entrée phase nationale/National Entry: 2011/12/22
 (86) N° demande PCT/PCT Application No.: US 2010/039834
 (87) N° publication PCT/PCT Publication No.: 2010/151680
 (30) Priorité/Priority: 2009/06/24 (US61/220,067)

(51) Cl.Int./Int.Cl. *F16K 27/00* (2006.01),
F16K 51/00 (2006.01)
 (71) Demandeur/Applicant:
S.M.P. FLOW CONTROL, INC., US
 (72) Inventeurs/Inventors:
KUGELEV, VLADIMIR, US;
MATZNER, MARK D., US
 (74) Agent: GOWLING LAFLEUR HENDERSON LLP

(54) Titre : SOCLE POUR UNE SOUPAPE DE LIMITATION DE PRESSION
 (54) Title: STAND FOR PRESSURE RELIEF VALVE

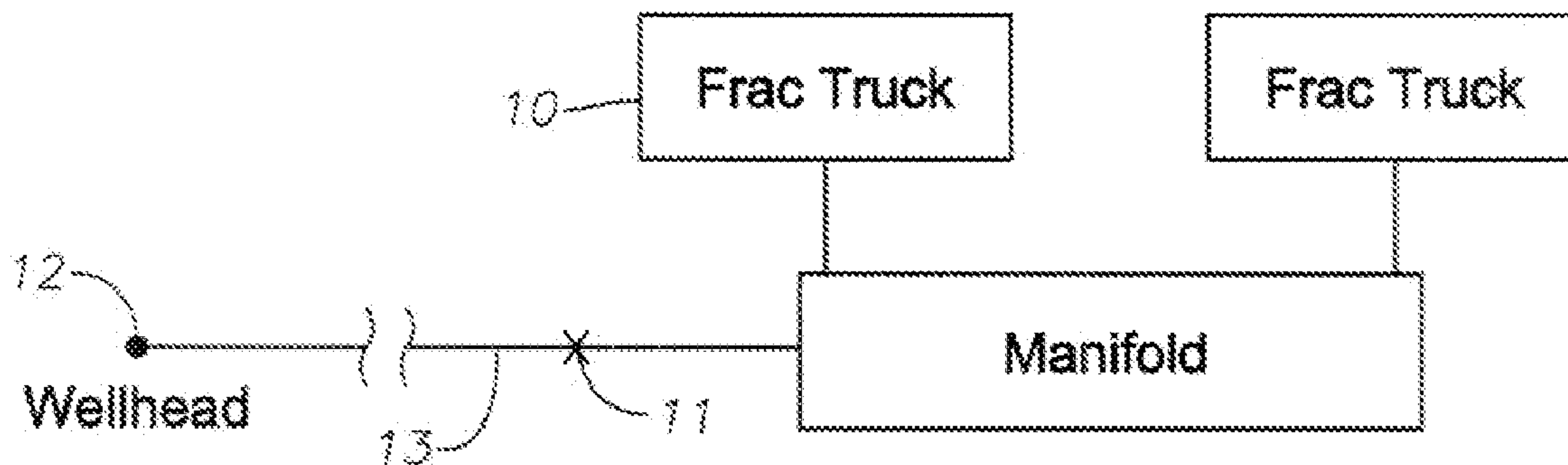

Fig. 1

(57) **Abrégé/Abstract:**

A frame for supporting a pressure relief valve located within a frac line connected to high pressure pumps on frac tracks. A metallic base is formed from rectangular tubing in the shape of a box. Saddles on the base support a tee on the lower portion of the relief valve. Brace links are connected at one end to the corners of the metallic base and swivel about clevises to allow access to the pressure relief valve. The other end of the brace links connect to clevises on a flange when assembled. The flange is rigidly connected to an upper portion of the relief valve to stabilize the assembly. Lifting loops on the flange allow the frame to be lifted during assembly.

(12) INTERNATIONAL APPLICATION PUBLISHED UNDER THE PATENT COOPERATION TREATY (PCT)

(19) World Intellectual Property Organization
International Bureau(43) International Publication Date
29 December 2010 (29.12.2010)(10) International Publication Number
WO 2010/151680 A3

(51) International Patent Classification:

F16K 27/00 (2006.01) F16K 51/00 (2006.01)

(21) International Application Number:

PCT/US2010/039834

(22) International Filing Date:

24 June 2010 (24.06.2010)

(25) Filing Language:

English

(26) Publication Language:

English

(30) Priority Data:

61/220,067 24 June 2009 (24.06.2009) US

(71) Applicant (for all designated States except US): **WEIR SPM, INC.** [US/US]; 7601 Wyatt Drive, Fort Worth, TX 76108 (US).

(72) Inventors; and

(75) Inventors/Applicants (for US only): **KUGELEV, Vladimir** [US/US]; 4809 Alleydale Court, Arlington, TX 76013 (US). **MATZNER, Mark, D.** [US/US]; 2009 Tarver, Burleson, TX 76028 (US).(74) Agent: **BRADLEY, James, E.**; P.O. Box 61389, Houston, TX 77208-1389 (US).

(81) Designated States (unless otherwise indicated, for every kind of national protection available): AE, AG, AL, AM, AO, AT, AU, AZ, BA, BB, BG, BH, BR, BW, BY, BZ,

CA, CH, CL, CN, CO, CR, CU, CZ, DE, DK, DM, DO, DZ, EC, EE, EG, ES, FI, GB, GD, GE, GH, GM, GT, HN, HR, HU, ID, IL, IN, IS, JP, KE, KG, KM, KN, KP, KR, KZ, LA, LC, LK, LR, LS, LT, LU, LY, MA, MD, ME, MG, MK, MN, MW, MX, MY, MZ, NA, NG, NI, NO, NZ, OM, PE, PG, PH, PL, PT, RO, RS, RU, SC, SD, SE, SG, SK, SL, SM, ST, SV, SY, TH, TJ, TM, TN, TR, TT, TZ, UA, UG, US, UZ, VC, VN, ZA, ZM, ZW.

(84) Designated States (unless otherwise indicated, for every kind of regional protection available): ARIPO (BW, GH, GM, KE, LR, LS, MW, MZ, NA, SD, SL, SZ, TZ, UG, ZM, ZW), Eurasian (AM, AZ, BY, KG, KZ, MD, RU, TJ, TM), European (AL, AT, BE, BG, CH, CY, CZ, DE, DK, EE, ES, FI, FR, GB, GR, HR, HU, IE, IS, IT, LT, LU, LV, MC, MK, MT, NL, NO, PL, PT, RO, SE, SI, SK, SM, TR), OAPI (BF, BJ, CF, CG, CI, CM, GA, GN, GQ, GW, ML, MR, NE, SN, TD, TG).

Published:

- with international search report (Art. 21(3))
- before the expiration of the time limit for amending the claims and to be republished in the event of receipt of amendments (Rule 48.2(h))

(88) Date of publication of the international search report:

31 March 2011

(54) Title: STAND FOR PRESSURE RELIEF VALVE

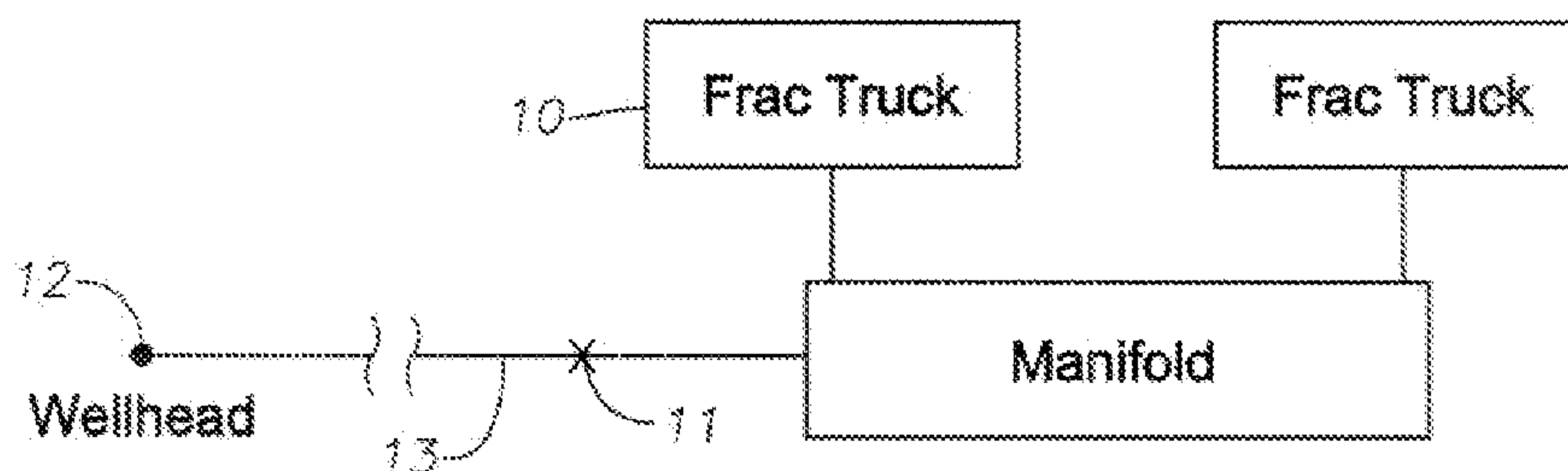

Fig. 1

(57) Abstract: A frame for supporting a pressure relief valve located within a frac line connected to high pressure pumps on frac tracks. A metallic base is formed from rectangular tubing in the shape of a box. Saddles on the base support a tee on the lower portion of the relief valve. Brace links are connected at one end to the corners of the metallic base and swivel about clevises to allow access to the pressure relief valve. The other end of the brace links connect to clevises on a flange when assembled. The flange is rigidly connected to an upper portion of the relief valve to stabilize the assembly. Lifting loops on the flange allow the frame to be lifted during assembly.

NON-PROVISIONAL PATENT APPLICATION

ATTORNEY DOCKET: 0619JB.044272

INVENTORS: Vladimir Kugelev
Mark D. Matzner**STAND FOR PRESSURE RELIEF VALVE****Cross-Reference to Related Application**

This application claims priority to provisional application 61/220,067, filed June 24, 2009, and is herein incorporated by reference in its entirety.

Field of the Invention

This invention relates in general to fracturing and other high pressure oilfield operations, and, in particular, to a stand for a pressure relief valve that prevents the valve from tipping over when flow lines move during operation and when pressure is released.

Background of the Invention

[0001] One type of treatment for an oil or gas well is referred to as well fracturing or a well "frac." The operator connects an adapter to the upper end of a wellhead member such as a tubing head and pumps a liquid at a very high pressure down the well to create fractures in the earth formation. The operator also disburses beads or other proppant material, also known as frac media, in the fracturing fluid to enter the cracks to keep them open after the high pressure is removed. This type of operation is particularly useful for earth formations that have low permeability but adequate porosity and contain hydrocarbons, as the hydrocarbons can flow more easily through the fractures created in the earth formation.

[0002] To introduce the frac media into the formation, high pressure pumps typically mounted on trucks, are employed at a well site. Frac lines are connected to the pumps and connected to the wellhead. The pressure employed during the frac operation may be many times the natural earth formation pressure that ordinarily would exist. For example, the operator might pump the fluid at a pressure of 8,000 to 9,000 psi. The normal pressure that might exist in the wellhead might be only a few hundred to a few thousand psi. Because of this, the frac lines experience high pressures that can be dangerous to personnel and destructive to equipment. Pressure relief valves are thus used to relieve pressure in the frac lines. However, the pressure relief valves may topple due to the pressure in the frac line. Improvements to the stability of the pressure relief valve are sought.

Summary of the Invention

[0003] A frame for supporting a pressure relief valve located within a frac line connected to high pressure pumps on frac trucks . A metallic base is formed from rectangular tubing in the shape of a box. Saddles on the base support a tee on the lower portion of the relief valve. Brace links are connected at one end to the corners of the metallic base and swivel about clevises to allow access to the pressure relief valve. The other end of the brace links connect to clevises on a flange when assembled. The flange is rigidly connected to an upper portion of the relief valve to stabilize the assembly. Lifting loops on the flange allow the frame to be lifted during assembly.

[0004] In an embodiment of the present technique, a frame for a pressure relief valve is provided that provides a stable base for the pressure relief valve. The frame has a metallic base that can be set on the ground. The metallic base can be fabricated from rectangular tubing joined end to end to form a rectangular box. For added stability, gussets can be used at each corner. Saddles are fastened to cross braces on the lower portion of the metallic base. A clamp fastens to the saddles

to secure a tee located at the bottom end of the pressure relief valve. The tee connects to frac lines running from frac trucks and to the wellhead.

[0005] Brace links are connected to clevises located on each top corner of the metallic base. The clevises are oriented inward at approximately a 45 degree angle and function to allow swiveling of the brace links. This allows for access to the valve when the links are not connected at their top ends. A flange with clevises is bolted to an upper end of the pressure relief valve, such as a cylinder operating the valve. The upper ends of the brace links are then fastened to the clevises. The flange also has lifting loops that allow lifting during assembly. In addition, a lifting loop can be welded to the top of the valve to allow lifting of the frame and valve assembly as a whole. The result is a rigid frame that advantageously provides stability to the pressure relief valve while allowing access to the pressure relief valve for maintenance.

Brief Description of the Drawings

[0006] FIG. 1 is a schematic layout of one embodiment of a frac job showing the location of valve stand assemblies, and is constructed in accordance with the invention;

[0007] FIG. 2 is an enlarged side view of one embodiment of a stand assembly for a pressure relief valve assembly, and is constructed in accordance with the invention;

[0008] FIG. 3 is a different side view of the stand assembly of FIG. 2, and is constructed in accordance with the invention;

[0009] FIG. 4 is an enlarged side view of a frame for the stand assembly, and is constructed in accordance with the invention;

[0010] FIG. 5 is a different side view of the stand assembly of FIG. 4, and is constructed in accordance with the invention;

[0011] FIG. 6 is a an enlarged top view the stand assembly of FIG. 4, and is constructed in accordance with the invention;

[0012] FIG. 7 is a an enlarged top view of a flange for the stand assembly, and is constructed in accordance with the invention;

[0013] FIG. 8 is a side view of the flange of FIG. 7, and is constructed in accordance with the invention.

Detailed Description of the Invention

[0014] Referring to FIG. 1, one embodiment of a fracturing (frac) job layout is schematically illustrated to show typical locations for a plurality of pressure relief valve assemblies 11. High pressure pumps on frac trucks 10 are connected to the wellhead 12 via flow frac lines 13 as shown. The pressure relief valve assembly 11 is denoted with an "X" in the frac lines 13.

[0015] FIGS. 2 and 3 show different views of one embodiment of a stand assembly 30 used to support each pressure relief valve assembly 11; shown included with the stand assembly 30 is a tee 14 with coaxial ends shown generally horizontal and connected to the frac lines 13. A clamp 16 and screw 18 set secure the tee 14 of relief valve assembly 11 to a frame 32 (FIG. 2). The tee 14 also includes a vertical lead on which a plug valve 20 is mounted. An indicator 22 is provided with the plug valve 20 for indicating if the plug valve 20 is open or closed. A relief

valve 24 connects to a top portion of the plug valve 20. A cylinder 26 for operating the relief valve 24 has a loop 28 for lifting that is attached to the top portion of the relief valve 24. The loop 28 can be sized to allow lifting of the relief valve assembly 11.

[0016] In the illustrated embodiment, a stand assembly 30 comprising frame 32, brace links 34, and flanges 36, provides a frame for the relief valve assembly 11 and allows for lifting of the stand assembly 30. The brace links 34 are illustrated as generally elongated cylindrical members, the brace links 34 may optionally be tubular as well. Each brace link 34 is shown having an end that connects to the frame 32 with a bolt set 38. The other end of brace links 34 connect to the flanges 36 with a bolt set 38. In an example embodiment, the bolt sets 38 are tightened to make the stand assembly 30 rigid. In the example embodiments of FIGS. 2 and 3, one brace link 34 is located at each upper corner of the frame 32. The top ends of the brace links 34 are disposed inward to connect with the corners of the flanges 36.

[0017] As shown in FIGS. 4, 5, and 6, the frame 32 can be comprised of steel rectangular tubing 51 connected to each other and welded at the corners. Cornerpieces or gussets 52 can be provided at the corners to provide additional stability to the frame by coupling together vertical and horizontal tubing 51. As shown in a top view in FIG. 6, the assembled rectangular tubing 51 forms a rectangular frame 32. Frame 32 could be other shapes rather than rectangular. A plurality of saddles 54 are shown that are generally planar members having a semi-circular recess formed on an upward facing end. The saddles 54 may be welded to additional cross braces 55 shown horizontally mounted between lower side of frame 30. The cross braces 55 for the saddles 54 are connected at each end to parallel pieces of rectangular tubing 51 that on opposing sides of the frame 30 that form a lower portion 50 of the frame 30. The ends of cross braces 55 can be welded to the rectangular tubing 51. The recess formed on the saddles 54 is formed to

receive the tee 14 of the relief valve assembly 11. The tee 14 is secured to each saddle 54 with clamp 16 and screws 18 that engage screw openings in the saddles (FIGS. 2 and 3). Pairs of planar clevises 58 are shown located at each of the top corners of the frame 32. Each pair of clevises 58 are generally parallel having a horizontal bore formed therethrough. Clevises 58 may be welded to the frame 32 and aligned with clevises 58 provided diagonally across the frame 32. The bores in each pair of clevises 58 is registerable with a bore provided in the lower end of each of the brace links 34. Inserting the bolt set 38 through the registered bores in the clevises 58 and lower end of the brace links 34 forms a swiveling coupling between the brace links 34 and the frame 32 (FIG. 2).

[0018] Enlarged views of an example embodiment of flange 36 are shown in FIGS. 7 and 8. The flange 36 is shown having a generally rectangular flange plate 62 with a pair of clevises 60 provided at adjacent corners disposed at opposing ends of an elongate side of the plate 62. The pairs of clevises 60 are shown angled away from one another. Each flange clevis 60 has a bore formed in a middle portion that can register with a bore provided in an upper end of one of the brace links 34. The brace link 34 may be secured to each pair of clevises 60 with a bolt set 38 inserted through the registered bores.

[0019] A U-shaped lifting loop 61 is illustrated having its free ends welded to each flange plate 62 to allow for lifting during assembly. During installation, slings may be looped through the loops 61 to allow for lifting of the combined assembly comprising the stand assembly 30 and relief valve assembly 11. Bolt openings 66 formed on the plate 62 and disposed in an arc along concave inner plate surface 64, allow bolts and nuts to fasten the flange 36 to the cylinder 26 of the relief valve assembly 11. Referring now to the example embodiment of FIG. 2, two flanges 36 are shown fastened to the relief valve assembly 11 on opposing sides of the cylinder 26. The

are 64 is formed to accommodate the outer curvature of the cylinder 26; thus a rigid connection is formed between the relief valve assembly 11 and the stand assembly 30. The top ends of the brace links 34 can be disconnected from the flanges 36 and swiveled diagonally outward at the frame clevises 58 to allow access to the valve assembly 11 and its components during maintenance.

[0020] In additional embodiments (not shown), a ball bearing swivel connection can be used in place of the clevises 58, 60 that receive the ends of the brace links 34.

[0021] In additional embodiments (not shown), a quick disconnect assembly can be used to connect the ends of the brace links 34 to the frame 32 and flanges 36.

[0022] In additional embodiments (not shown), the space between the saddles 54 can be adjusted to allow for varying sizes of tees 14.

[0023] The high pressures in fracking job flow lines create possible dangers during disassembly or disconnecting of in-line components. An inadvertent disconnection in the pressurized piping can result in uncontrolled and sudden movement of the piping as the high pressure fluid escapes. This creates an extreme hazard to surrounding persons, equipment, structure, or other property. Relief valve assemblies 11 can tip over during testing and operation and thus can cause injury to personnel or damage to equipment and property. Maintaining the relief valve assembly 11 in an upright position is thus an advantageous function of the stand assembly 30 of the present invention.

[0024] For example, the stand assembly 30 is rigidly connected to the valve assembly 11 at the tee 14 and at the cylinder 26. Saddles 54 located on the stand assembly 30 transfer the forces from the frac lines 13 to the frame 32 via the clamps 16 secured to the tee 14. Further, the top of the valve assembly 11 is maintained upright via the connection of the cylinder 26 to the flanges

36 on the stand assembly 30. Any forces transferred from the frac lines 13 up to the valve assembly 11 are transferred to the flanges 36 and down to the brace links 34 and frame 32. The stand assembly 30 is easily and conveniently preassembled and may be brought to the well site already assembled with valves 20, 24 and tee 14. Further, the top ends of the brace links 34 can be disconnected from the flanges 36 and swiveled diagonally outward at the frame clevises 58 to allow access to the valve assembly 11 and its components for maintenance. Thus, potential injury, death and/or loss of property due to a valve assembly tipping over are greatly reduced in a convenient and simple manner due to the stand assembly 30.

[0025] This written description uses examples to disclose the invention, including the best mode, and also enable a person of ordinary skill in the art to practice the invention, including making and using any devices or systems and performing any incorporated methods. These embodiments are not intended to limit the scope of the invention. The patentable scope of the invention is defined by the claims, and may include other examples that occur to those skilled in the art. Such other examples are intended to be within the scope of the claims if they have structural elements that do not differ from the literal language of the claims, or if they include equivalent structural elements with insubstantial differences from the literal language of the claims.

CLAIMS**WHAT IS CLAIMED IS:**

1. An apparatus for supporting a pressure relief valve that is attached to a main flow line, comprising:
 - a base set on the main flow line;
 - a flange on a portion of the pressure relief valve distal from the main flow line;
 - elongated support members each having a base end pivotingly coupled to the base and a flange end pivotingly coupled to the flange; and
 - selectively removable couplings for linking an end of the support members to the flange and an opposing end to the base, so that when a coupling is removed from an end of one of the support members to define a free end, the support member is rotatable about an axis defined by the coupling on the support member opposite the free end and allow access to the relief valve.

2. The apparatus of claim 1, wherein the base is rectangular and further comprises:
 - a plurality of saddles fastened to the metallic base and adapted for receiving a conduit;
 - a plurality of lower steel rectangular tubes joined end to end to form a rectangle;
 - a plurality of upper steel rectangular tubes joined end to end to form a rectangle;
 - the upper steel rectangular tubes displaced above the lower steel rectangular tubes;
 - a plurality of vertical steel rectangular tubes joining each of lower and upper steel rectangular tubes at each of a corner to form a box shape; and
 - a plurality of cross braces connected at each end to a pair of parallel rectangular tubes forming a portion of the lower steel rectangular tubes.

3. The apparatus of claim 2, wherein the saddles are fastened to the cross braces connected to the lower steel rectangular tubes.
4. The apparatus of claim 2, wherein the conduit received by the saddles is a tee connected to a lower portion of the relief valve, the tee secured to each saddles by a clamp fastened to each saddle.
5. The apparatus of claim 1, wherein the flange comprises at least one lifting loop welded to the flange for lifting during assembly.
6. The apparatus of claim 1, wherein the flange is rigidly fastened to an upper portion of the pressure relief valve via a set of bolt opening formed on the flange.
7. The apparatus of claim 1, wherein a lifting loop is welded to the top of the pressure relief valve to allow lifting of the support apparatus and pressure relief valve.
8. The apparatus of claim 1, wherein a plurality of clevises are located at each upper corner of the metallic base to receive the ends of the elongated support members connected to the base, the clevises oriented inward at a 45 degree angle to allow the elongated support members to swivel outward.

9. The apparatus of claim 1, wherein the couplings on the base are disposed farther away from an axis of the relief valve than the couplings on the flange so that the support members depend inward towards the relief valve with distance away from the base.
10. A pressure relief valve assembly, comprising:
- a pressure relief valve,
 - a hydraulic operator on an upper end of the valve;
 - a tee connected to a lower end of the valve connected to a frac line;
 - a base;
 - a plurality of saddles fastened to the base and having a curved recess in which the tee is set;
 - a plurality of links, each having a lower end connected to the base; and
 - a flange having a plate with a plurality of clevises connected to an upper end of the links, the flange adapted to closely receive a top end of the relief valve.
11. The apparatus of claim 10, wherein the metallic base is rectangular and further comprises:
- a plurality of lower steel rectangular tubes joined end to end to form a rectangle;
 - a plurality of upper steel rectangular tubes joined end to end to form a rectangle;
- the upper steel rectangular tubes displaced above the lower steel rectangular tubes;
- a plurality of vertical steel rectangular tubes joining each of lower and upper steel rectangular tubes at each of a corner to form a box shape; and

a plurality of cross braces connected at each end to a pair of parallel rectangular tubes forming a portion of the lower steel rectangular tubes.

12. The apparatus of claim 11, wherein the saddles are fastened to the cross braces connected to the lower steel rectangular tubes.

13. The apparatus of claim 10, wherein the tee is secured to each saddle by a clamp fastened to each saddle.

14. The apparatus of claim 10, wherein the flange comprises at least one lifting loop welded to the flange for lifting during assembly.

15. The apparatus of claim 10, wherein the flange is rigidly fastened to an upper portion of the pressure relief valve via a set of bolt opening formed on the flange.

16. The apparatus of claim 10, wherein a lifting loop is welded to the top of the pressure relief valve to allow lifting of the support apparatus and pressure relief valve.

17. The apparatus of claim 10, wherein a plurality of clevises are located at each upper corner of the metallic base to receive the ends of the links connected to the metallic base, the clevises oriented inward at a 45 degree angle to allow the links to swivel outward.

18. A pressure relief valve assembly, comprising:

a pressure relief valve,
a hydraulic operator for operating the valve located on an upper end of the valve;
a tee connected to a lower end of the valve adapted for connecting to a frac line;
a metallic base fabricated from a plurality of rectangular tubing members joined end to end to form a box;
a plurality of saddles fastened to a lower portion of the metallic base, a clamp fastened to each saddle to retain the tee on the saddles;
a plurality of links, each of links connected at one end to the upper corners of the metallic base by a plurality of clevises, the clevises oriented inward at 45 degrees and allowing the each of the links to swivel,
a pair of flanges having a plate with a plurality of clevises for connecting to each end of the free end of the links, the flange adapted to closely receive a top end of the relief valve, the flange having a bolt pattern for fastening to the cylinder portion of the relief valve; and
a lifting loop welded onto each of the flanges for allowing lifting; and
a lifting eye welded onto the top of the cylinder for lifting.

19. The assembly of claim 18, wherein the rectangular tubing members forming the metallic base further comprises:
a plurality of lower steel rectangular tubes joined end to end to form a rectangle;
a plurality of upper steel rectangular tubes joined end to end to form a rectangle;
the upper steel rectangular tubes displaced above the lower steel rectangular tubes;

a plurality of vertical steel rectangular tubes joining each of lower and upper steel rectangular tubes at each of a corner to form a box shape; and

a plurality of cross braces connected at each end to a pair of parallel rectangular tubes forming a portion of the lower steel rectangular tubes.

20. The assembly of claim 19, wherein each saddle is fastened to the cross braces.

1/5

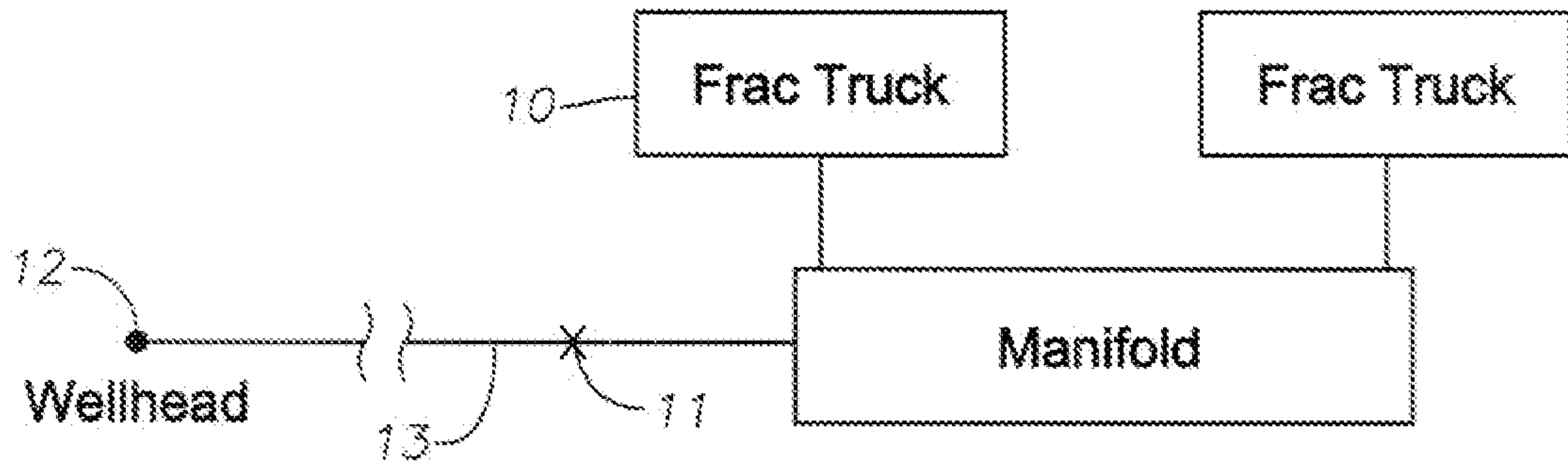

Fig. 1

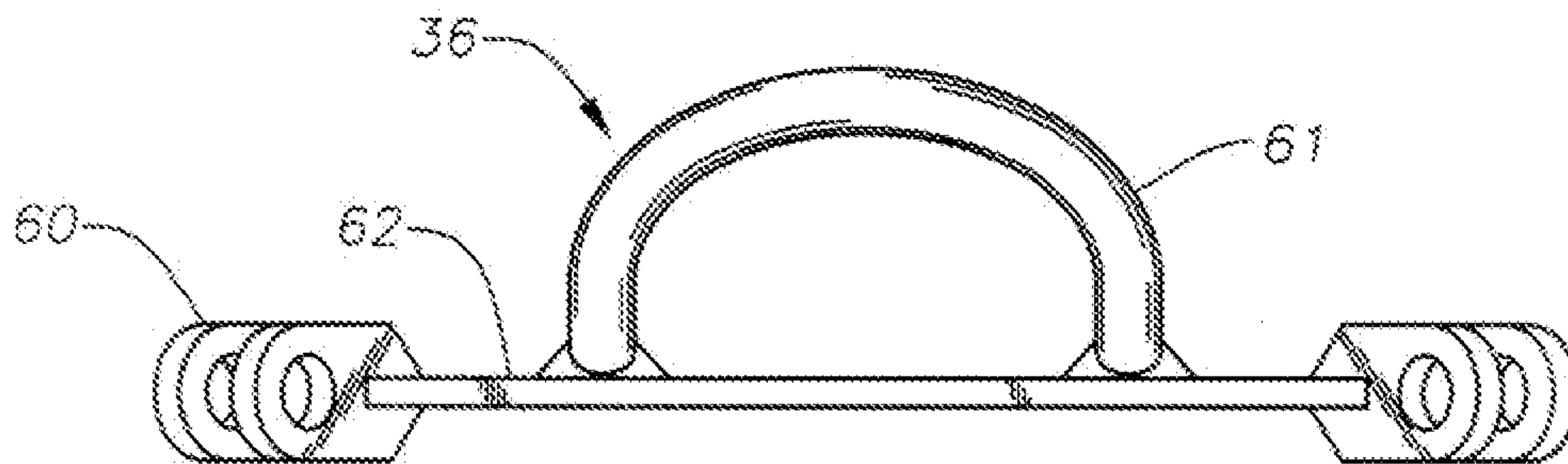

Fig. 8

2/5

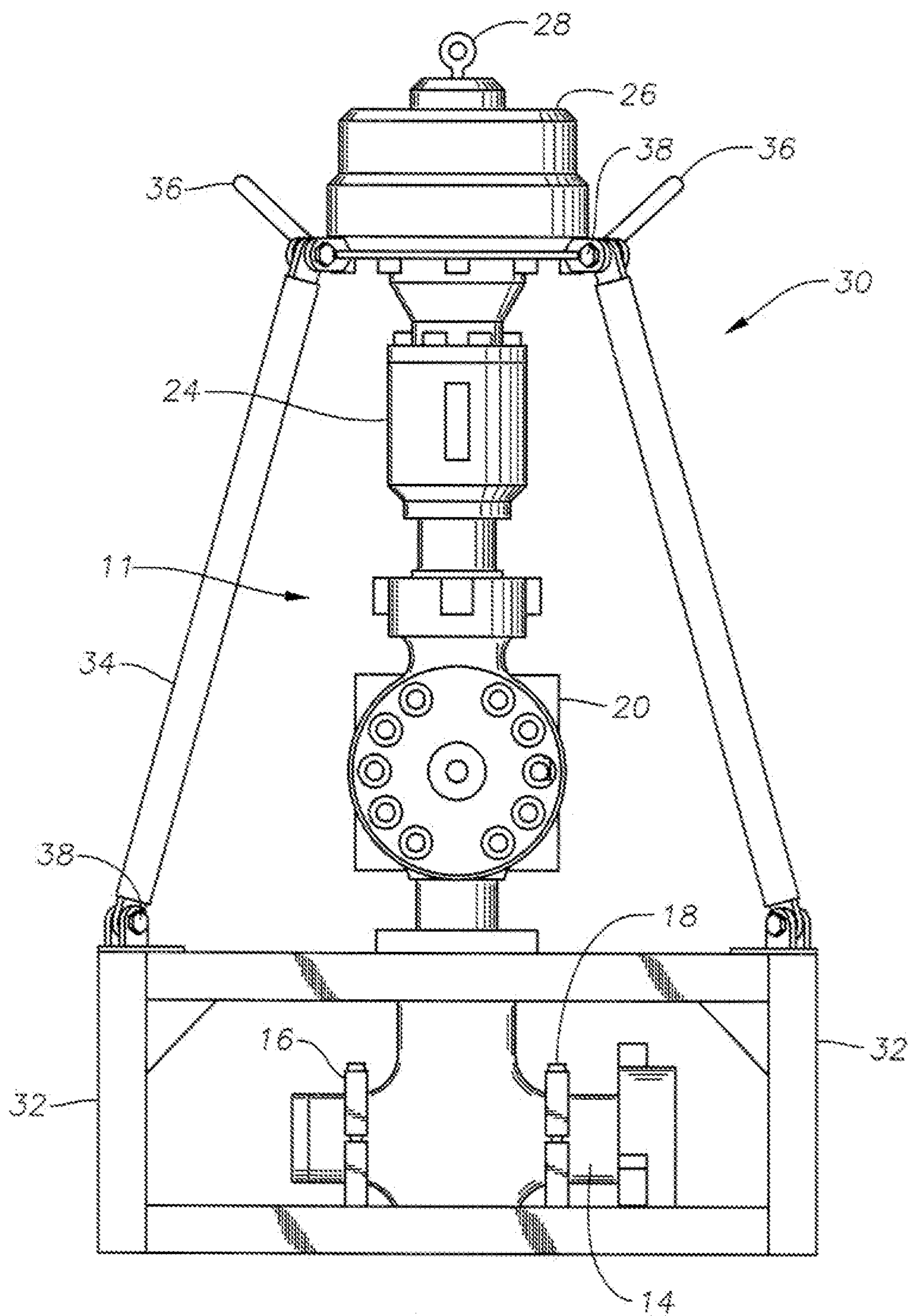

Fig. 2

3/5

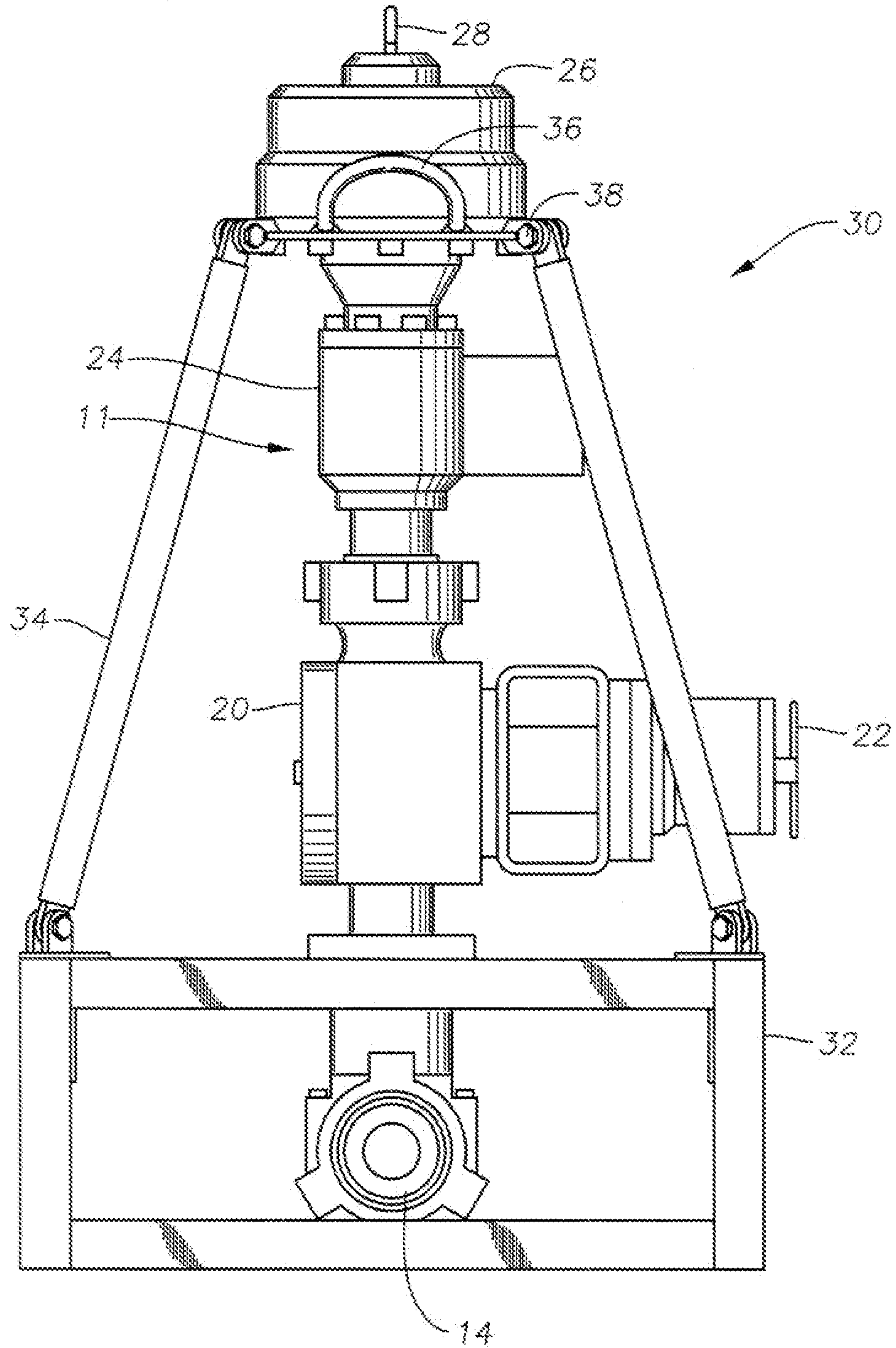

Fig. 3

4/5

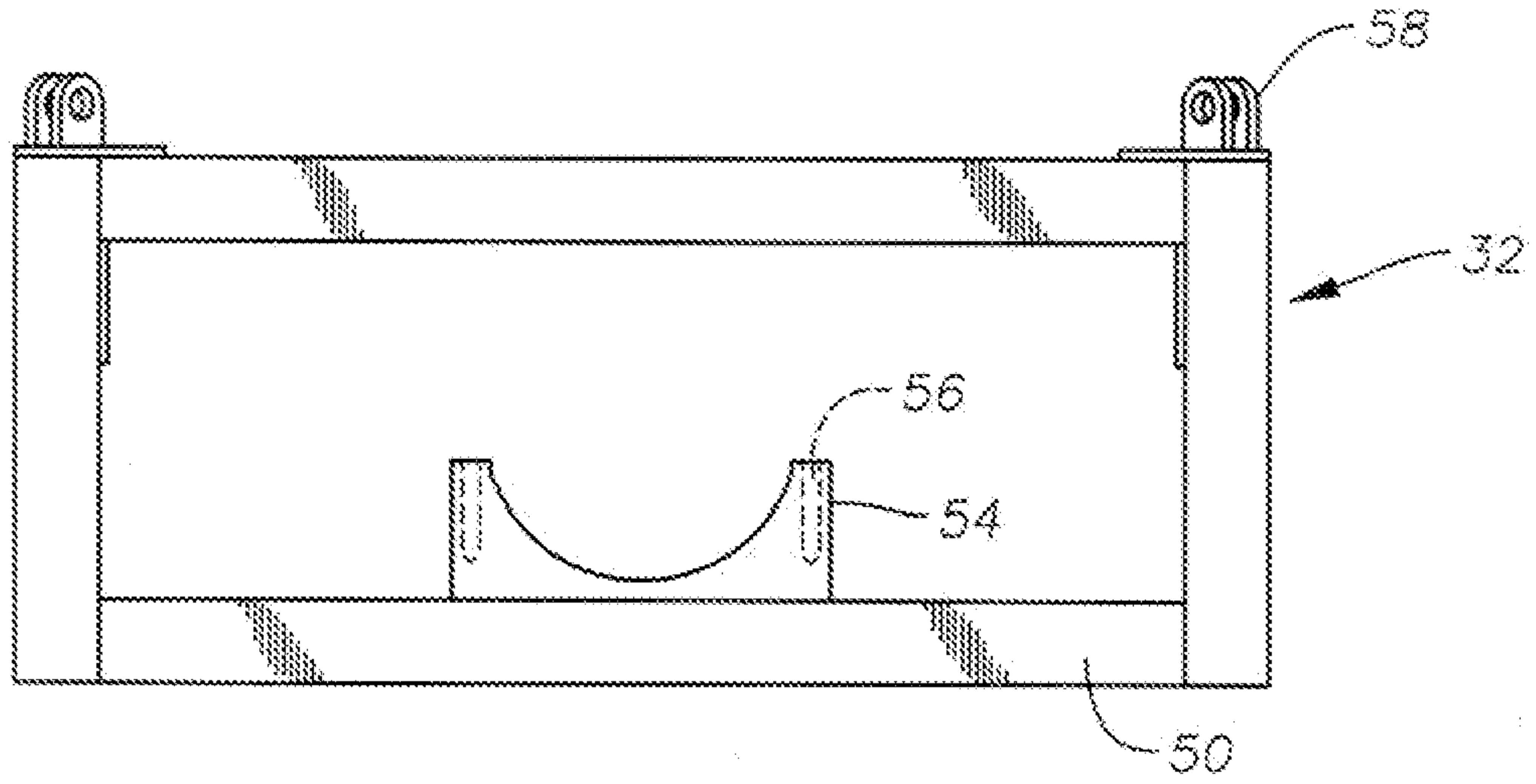

Fig. 4

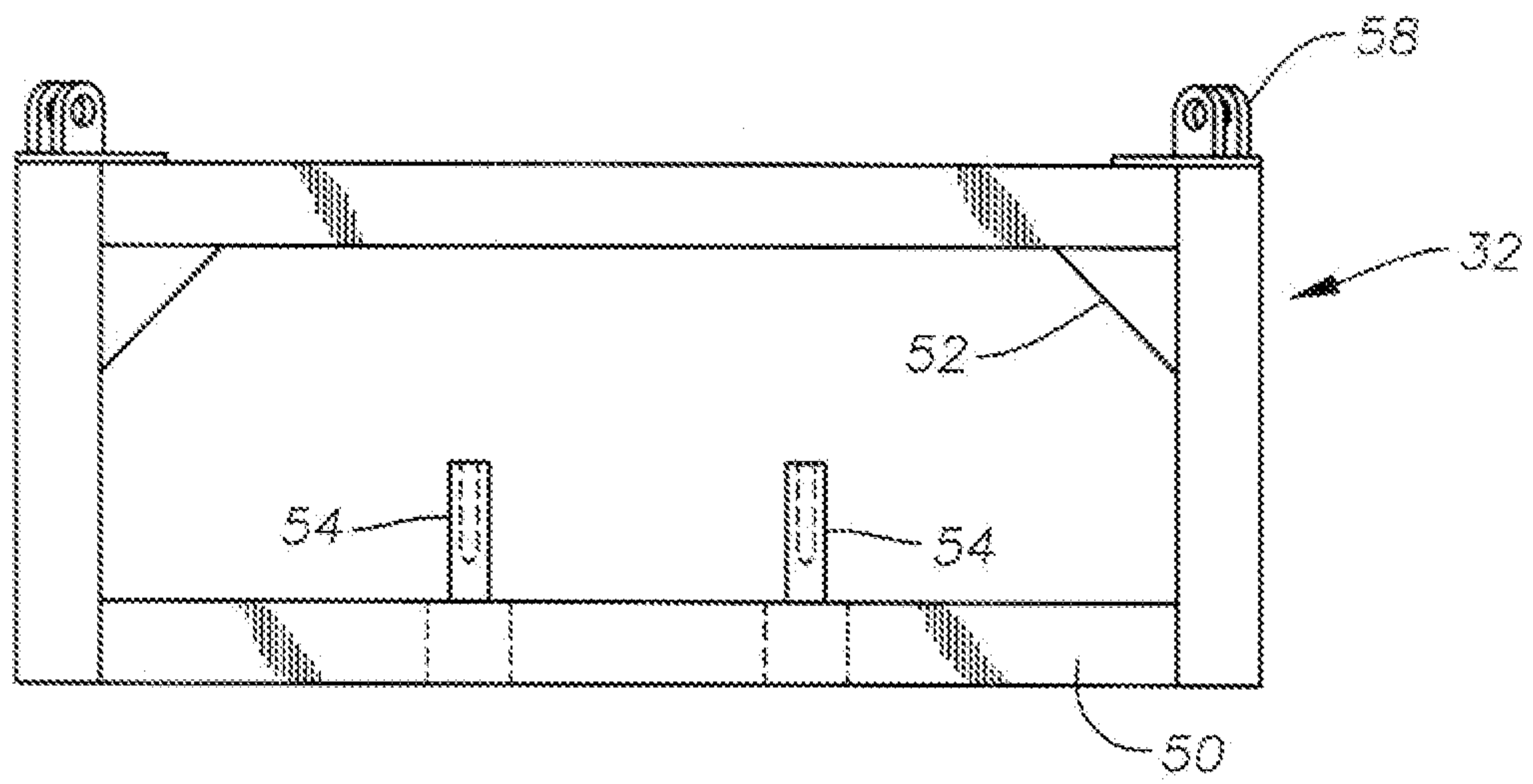

Fig. 5

5/5

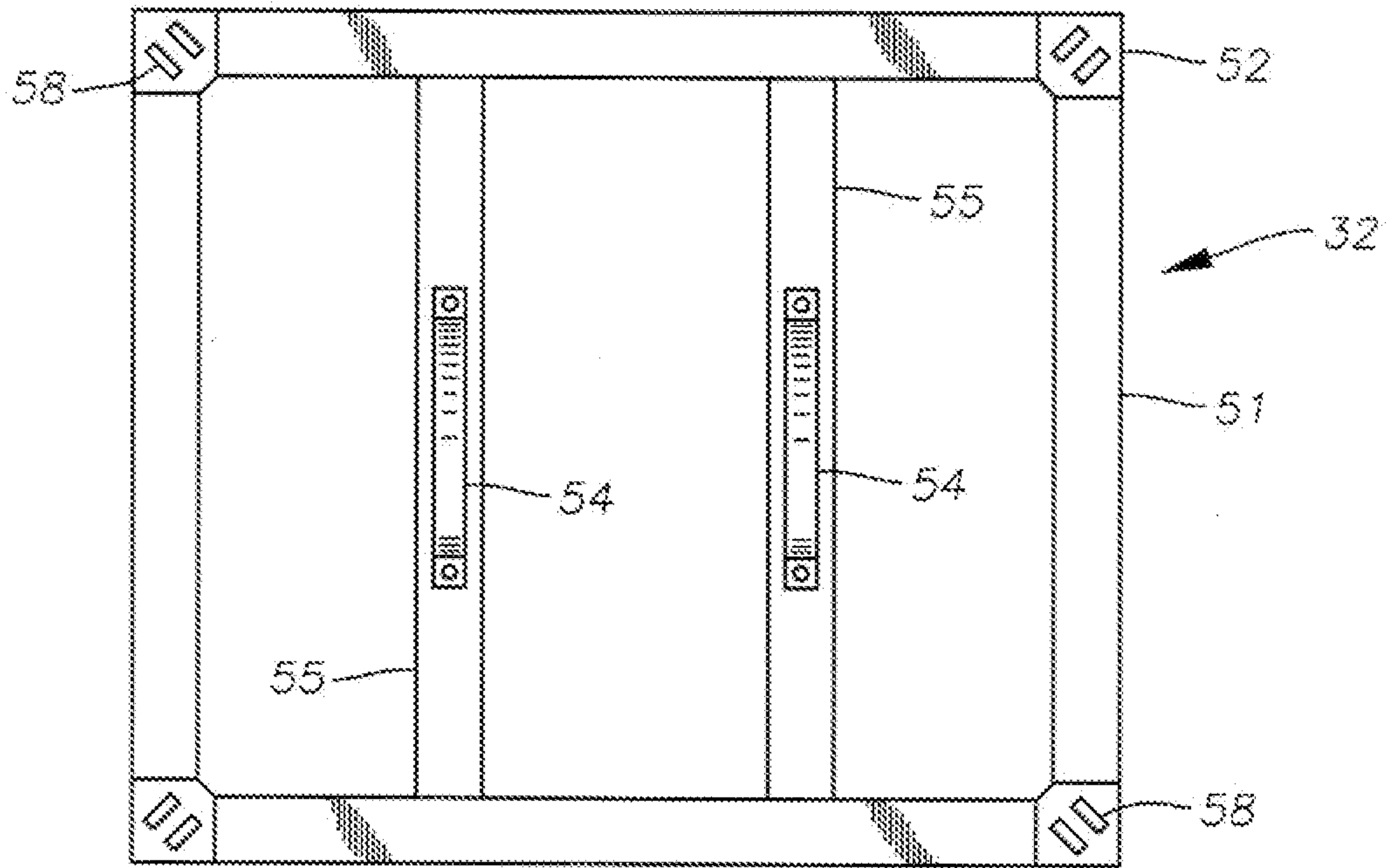

Fig. 6

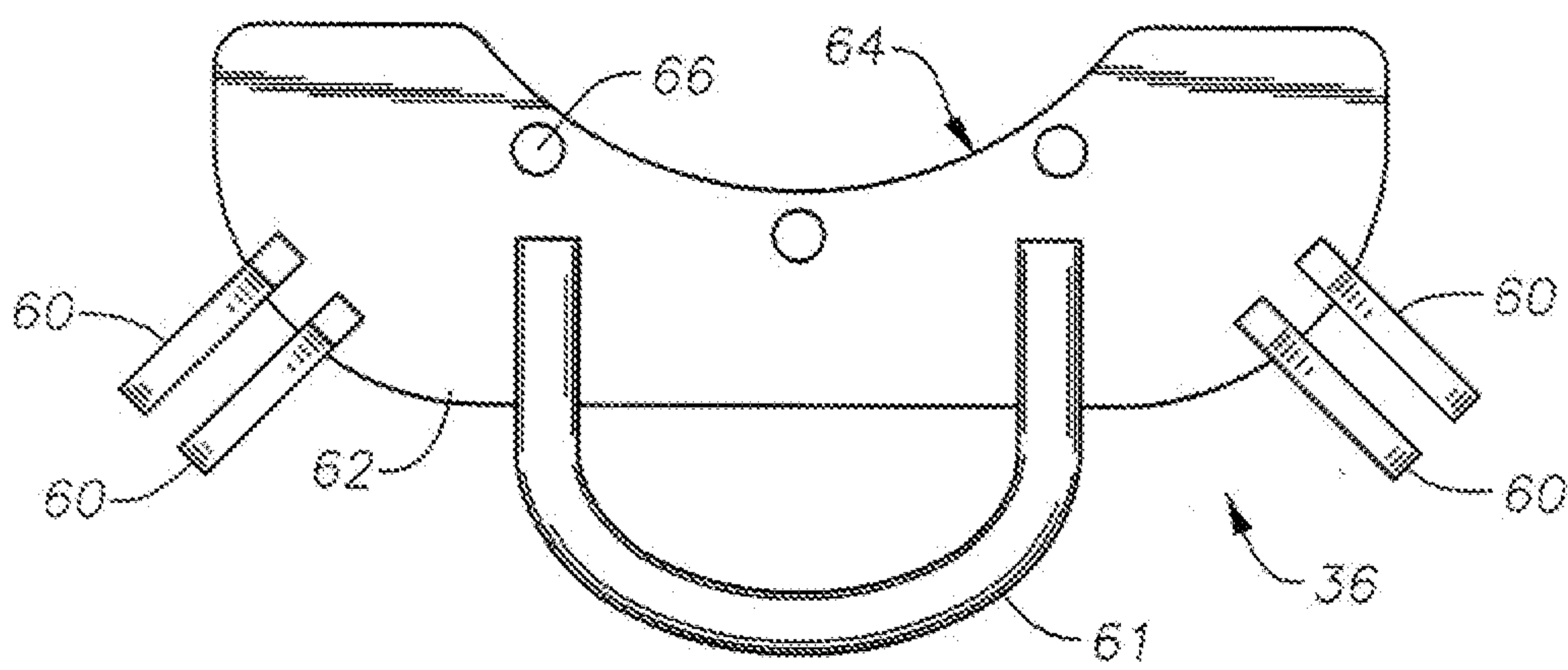

Fig. 7

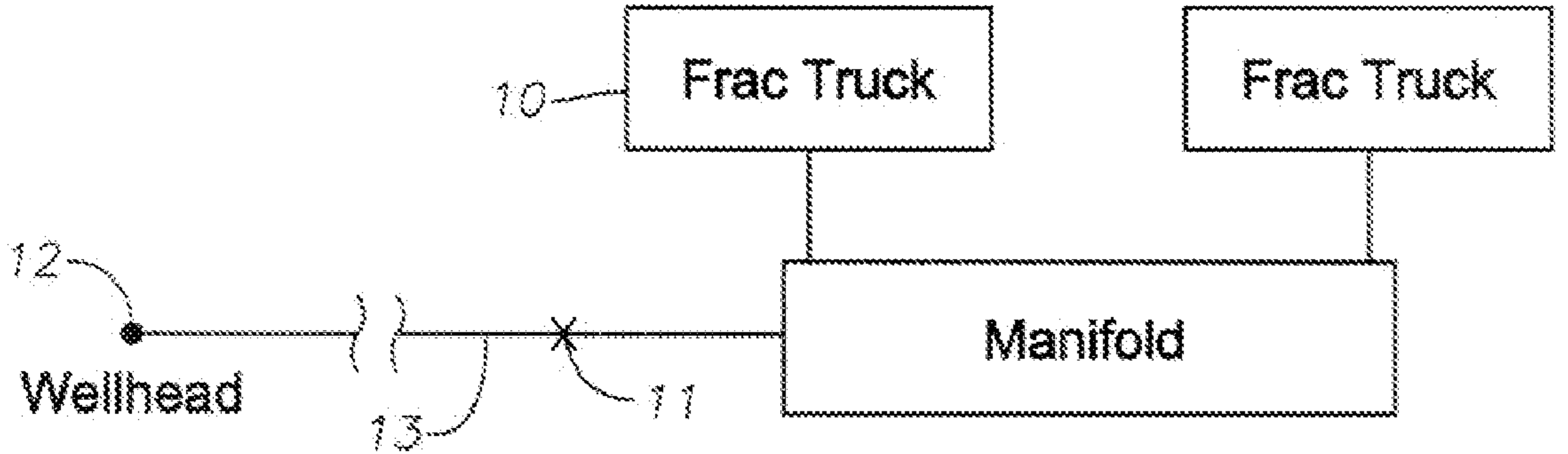

Fig. 1