

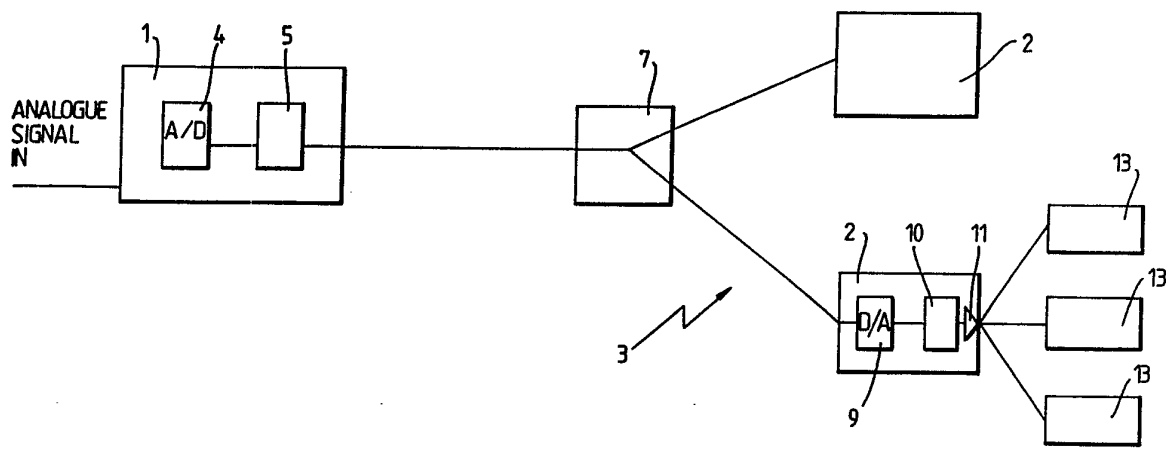

INTERNATIONAL APPLICATION PUBLISHED UNDER THE PATENT COOPERATION TREATY (PCT)

<p>(51) International Patent Classification ⁵ : H04N 7/22</p>	<p>A1</p>	<p>(11) International Publication Number: WO 91/15927 (43) International Publication Date: 17 October 1991 (17.10.91)</p>
<p>(21) International Application Number: PCT/GB91/00568 (22) International Filing Date: 10 April 1991 (10.04.91) (30) Priority data: 9008162.1 10 April 1990 (10.04.90) GB (71) Applicant (for all designated States except US): BRITISH TELECOMMUNICATIONS PUBLIC LIMITED COMPANY [GB/GB]; 81 Newgate Street, London EC1A 7AJ (GB). (72) Inventors; and (75) Inventors/Applicants (for US only) : COOK, Andrew, Robert, John [GB/GB]; Fishers Farm, Tendring, Clacton-on-Sea, Essex CO16 9AA (GB). FAULKNER, David, Wynford [GB/GB]; 1 Westland, Martlesham Heath, Ipswich, Suffolk IP5 7RE (GB).</p>		<p>(74) Agent: SEMOS, Robert, Ernest, Vickers; Intellectual Property Department, British Telecom, 151 Gower Street, London WC1E 6BA (GB). (81) Designated States: AT (European patent), BE (European patent), CA, CH (European patent), DE (European patent), DK (European patent), ES (European patent), FI, FR (European patent), GB (European patent), GR (European patent), IT (European patent), JP, LU (European patent), NL (European patent), NO, SE (European patent), US. Published With international search report.</p>

(54) Title: SIGNAL DISTRIBUTION



(57) Abstract

Signals, such as television signals, are distributed from a head-end station (1) via a fibre network (3). The signals are amplitude modulated on carriers at different frequencies, and the different carriers combined to form a composite analogue signal. In the head-end station (1) the composite analogue signal is clipped to reduce the peak-to-mean ratio and the clipped composite signal is digitised. The resulting digital data is transmitted onto the fibre network and is received at an optical receiver (2). The optical receiver (2) reconstitutes the composite analogue signal for reception by a termination. In one example the composite analogue signal has a bandwidth of one octave or less, and is digitised by sampling at a sampling rate below the Nyquist rate.

FOR THE PURPOSES OF INFORMATION ONLY

Codes used to identify States party to the PCT on the front pages of pamphlets publishing international applications under the PCT.

AT	Austria	ES	Spain	MG	Madagascar
AU	Australia	FI	Finland	ML	Mali
BB	Barbados	FR	France	MN	Mongolia
BE	Belgium	GA	Gabon	MR	Mauritania
BF	Burkina Faso	GB	United Kingdom	MW	Malawi
BG	Bulgaria	GN	Guinea	NL	Netherlands
BJ	Benin	GR	Greece	NO	Norway
BR	Brazil	HU	Hungary	PL	Poland
CA	Canada	IT	Italy	RO	Romania
CF	Central African Republic	JP	Japan	SD	Sudan
CG	Congo	KP	Democratic People's Republic of Korea	SE	Sweden
CH	Switzerland			SN	Senegal
CI	Côte d'Ivoire	KR	Republic of Korea	SU	Soviet Union
CM	Cameroon	LI	Liechtenstein	TD	Chad
CS	Czechoslovakia	LK	Sri Lanka	TG	Togo
DE	Germany	LU	Luxembourg	US	United States of America
DK	Denmark	MC	Monaco		

SIGNAL DISTRIBUTION

The present invention relates to the distribution of signals on a network and in particular to the distribution of AM (amplitude modulated) television signals.

Conventionally, television has been broadcast as AM signals with different channels modulated onto sub-carriers at different frequencies. Existing cable television services using copper coaxial cable have adopted corresponding analogue AM techniques to provide channels in a region of the same UHF spectrum used for broadcast television.

It is now proposed to use cable networks such as fibre optic networks for the distribution of television signals. The wide bandwidth offered by such networks offers the possibility of upgrading to carry future wideband services such as HDTV and the same network may also be used for services other than television, such as telephony. However whilst the use of AM techniques is necessary if the television signals are to be received by conventionally equipped television sets there are a number of problems associated with the use economically of AM techniques on optical networks. In particular the carrying of AM optical signals requires less splitting in order to allow a high power budget, and the use of highly specified linear opto-electronic devices.

According to the present invention, a method of distributing signals from a head-end station via an network comprises combining a plurality of AM channels modulated on sub-carriers at different frequencies to form a composite analogue signal, treating the composite analogue signal to reduce the peak-to-mean ratio, digitising the composite analogue signal, transmitting resulting digital data onto the network, receiving the

digital data at a receiver and reconstituting the composite analogue signal for reception at a termination.

Preferably the network is an optical network and the receiver is an optical receiver. Preferably the composite analogue signal is treated by clipping the signal.

A preferred aspect of the present invention provides a method of distributing, e.g., television signals which is particularly well-adapted to use with optical networks whilst at the same time maintaining compatibility with conventional analogue television sets. As noted above, television signals used for terrestrial broadcasting are modulated onto sub-carriers at different frequencies. When a composite signal is formed by adding together the different channels the resulting waveform has a much higher peak-to-mean ratio than the individual carriers. It is therefore possible to clip or compress the maxima and minima before quantising without significantly degrading the performance. The A/D converter used for digitising the signal can then operate over a more restricted input amplitude range and so requires fewer quantisation levels to achieve an adequate output video signal-to-noise ratio.

Preferably the method includes receiving the digitised signal at a node remote from the termination and transmitting the reconstituted signal onwards for reception at the termination.

The detection of the digital data is advantageously carried out at a node such as a distribution box or pedestal near the customer's premises. The television signals may then be delivered over conventional coaxial cable in a standard format, avoiding the need for a special adapter or other equipment at the customer-end.

Preferably the composite analogue signal has a bandwidth of one octave or less and is digitised by sampling at a sampling rate below the Nyquist rate.

Preferably, in addition to or as an alternative to clipping the composite analogue signal the method further comprises compressing the composite analogue signal at the head-end station and applying complementary expansion at the receiver.

Companding may be carried out either in the analogue or in the digital domain and preferably the compression function is the cumulative distribution function of the Gaussian probability distribution function.

According to a further aspect of the present invention there is provided a system for distributing signals comprising a head-end station, one or more receivers, and a network connecting the head-end station to the or each receiver, the head-end station including an input stage arranged to receive a composite analogue signal comprising a plurality of AM channels modulated on sub-carriers at different frequencies, converter means arranged to treat the composite analogue signal to reduce the peak-to-mean ratio and to digitise the composite analogue signal, and transmitter means arranged to transmit the resulting digital data onto the network, the receiver including reconstituting means arranged to reconstitute the composite analogue signal and output means arranged to output the composite analogue signal for reception by a termination.

A method and system in accordance with the present invention will now be described in further detail with reference to the accompanying drawings, in which:

Figure 1 is a block diagram showing a distribution system;

Figure 2 is a block diagram showing a signal path in greater detail;

Figure 3 is a diagram showing an alternative arrangement for the multiplexer of Figure 2; and

Figures 4a - 4d are diagrams showing sub-carriers and a composite signal.

A system for distributing television signals via an optical fibre network comprises a head-end station 1 and a number of optical receivers 2 connected to the head-end station 1 via a fibre network 3. In the present example the fibre network 3 is a passive optical network using a star topology but the present invention is equally applicable to other fibre optic networks using different topologies.

The head-end station 1 receives at its input a composite analogue signal which in the present example covers the spectrum from 470-860 MHz. This input signal comprises sub-carriers at different frequencies amplitude-modulated with different television signals. These signals are input to an A/D converter 4 which, as described in further detail below, clips and digitises the signal. An optical transmitter 5 modulates an optical signal with the digital data output by the A/D converter and outputs the signal onto the fibre network 3. The signal passes through different stages of the fibre network 3, including one or more passive optical splitters 7 and is received by the optical receivers 2. For clarity only two optical receivers 2 are shown in Figure 1, but in practice many more may be connected to each network. At the receivers 2 which may, for example, be positioned in street cabinets, the composite optical signal is reconstituted from the optical data and output as an analogue signal via coaxial cables 8 to conventional television sets 13.

The signal path from the head-end station 1 to the television set is shown in greater detail in Figure 2. Data is output from the A/D converter 4 in parallel as

8-bit words. An 8:1 multiplexer 8 converts the output from the A/D converter 4 to a serial bit stream. This bit stream is used to modulate the output from the optical transmitter 5 using conventional techniques. The operation of the multiplexer 8 is locked to a 7 GHz clock generated locally in the head-end station. This clock signal is divided by eight to provide a lower rate clock for the A/D converter 4. In transmission over the fibre network 3 the signal output by the transmitter 5 may be split up to 49 ways, within the constraints of the power budget in the present example. At the receiver 2 a 1:8 demultiplexer 12 assembles 8-bit parallel words from the serial datastream and outputs those 8-bit words to a D/A converter 9. The output from the D/A converter 9 passes through a band pass filter 10 and via an output amplifier stage 11 to up to 20 different television sets 13 connected to the receiver 2 by conventional coaxial cables.

The system may be used to distribute signals to so-called "cable ready" sets. Such sets typically have a VHF baseband input up to 450 MHz. For such systems use can be made of aliasing channels present in the lower frequency range. These are channels at frequencies below those of the original components of the composite analogue signal which are generated as a result of sampling below the Nyquist rate. In this case the reconstituting filter 10 is a low-pass filter rather than a band-pass filter. The low frequency channels output from the reconstituting filter are inverted unless the input to the A/D converter is first inverted.

Figures 4a - 4d, show schematically the formation of the composite analogue signal from three carriers c_1, c_2, c_3 . The carriers have amplitudes p_1, p_2, p_3 respectively. The mean (rms) level of each carrier is then $p_n / (2 \sqrt{2})$. The different component carriers add

together to form the composite signal shown in Figure 4d. It can be shown that the amplitude of the composite signal, when it comprises n channels, each of amplitude p is np and its mean level is $n(p/2\sqrt{2})$. The peak-to-mean ratio of the composite signal is therefore far greater than that of the individual sub-carriers. At the input to the A/D converter relatively severe clipping may be applied to limit the dynamic range of the signal prior to quantisation making it possible to minimise the number of quantisation levels without significant loss in the quality of the signal. Clipping may be applied using an appropriate clipping stage before the A/D converter. Alternatively if that converter has suitable clipping characteristics clipping may be achieved by overloading it by a suitable margin.

The composite analogue signal is limited in bandwidth to less than one octave. Not only does this serve to reduce second order intermodulation distortion but it makes possible sampling at a rate below the Nyquist minimum, that is twice the frequency of the maximum frequency component of the signal. Sampling below the Nyquist rate causes aliasing distortion. When however the signal is confined to less than one octave and sampled at a rate only slightly greater than the maximum frequency component the aliasing distortion falls in the unused frequency band below the signal octave band. The aliasing distortion therefore does not compromise the performance of the system and the bit rate of the system is only one half that needed for full Nyquist sampling. As noted above, when generating signals for cable-ready VHF TV sets the production of low frequency aliasing channels may be used to shift the received channels into the desired frequency range.

The A/D converter 4 defines a number of amplitude bands and determines which amplitude band matches the

sample value. Each amplitude band is represented by a binary word and a byte is output accordingly. The resultant bit rate when these bytes are converted to a serial stream by the 8:1 multiplexer 8, is the product of the sampling rate and the number of digits in a byte. Clipping minimises the number of quantisation levels required and so enables a reduction in the byte size and bit rate.

Optionally compression may be applied to the signal before or after it is sampled by the A/D converter 4. Known A/D converters for video signals use linear quantising with one output byte representing one quantisation level. The present system however by applying compression to the composite analogue signal as it is digitised reduces the number of possible output words required for a given output video quality by a factor of two or more, giving a further saving in the bit rate. The preferred compression function is the cumulative distribution function of the Gaussian probability distribution function (PDF). If the input waveform to the compressor has a Gaussian PDF, the output PDF from the compressor is uniform with output in the range 0 to 1. This uniform PDF can then be quantised linearly and each output codeword is then equi-probable. The compressor and matching expander at the receiver may be realised in hardware using a network of diodes and resistors, or in software using a look-up table following a suitable linear A/D converter.

The digital circuits in the head-end station 1 and the receiver 2 are synchronised using word alignment techniques. For example, the least significant bit in each word may be identified by a periodic function such as a Barker code by regular bit stealing. This sequence is then detected using a suitable sampler, logic function

and clock slip circuit. Preferably the clock operates at the word rate rather than the serialised bit rate.

In an alternative arrangement shown in Figure 3 two 8:1 multiplexers are used in parallel at a lower clock rate of 1.2 GHz. In this case a pair of A/D converters are used, operating at a clock rate one eighth of that of the multiplexers.

Although the embodiment discussed above relates to the distribution of television signals, the invention, in its broadest aspects, is applicable to other signals such as, e.g., audio signals.

CLAIMS

1. A method of distributing signals from a head-end station via a network comprising combining a plurality of AM channels modulated on sub-carriers at different frequencies to form a composite analogue signal, treating the composite analogue signal to reduce the peak-to-mean ratio, digitising the composite analogue signal, transmitting resulting digital data onto the network, receiving the digital data at a receiver and reconstituting the composite analogue signal for reception at a termination.
2. A method according to claim 1, in which the network is an optical network, the receiver is an optical receiver, and the composite analogue signal is treated by clipping the signal.
3. A method according to claim 1 or 2, including receiving the digitised signal at a node remote from the termination, and transmitting the reconstituted signal onwards for reception at the termination.
4. A method according to claim 2 or 3, in which the composite analogue signal has a bandwidth of one octave or less and is digitised by sampling at a sampling rate below the Nyquist rate.
5. A method according to any one of claims 1 to 4, including compressing the composite analogue signal at the head-end station and applying complementary expansion to the signal at the receiver.
6. A system for distributing signals comprising a head-end station, one or more receivers, and a network connecting the head-end station to the or each receiver, the head-end station including an input stage arranged to receive a composite analogue signal comprising a plurality of AM channels modulated on sub-carriers at different frequencies, converter means arranged to treat

the composite analogue signal to reduce the peak-to-mean ratio and to digitise the composite analogue signal, and transmitter means arranged to transmit the resulting digital data onto the network, the receiver including reconstituting means arranged to reconstitute the composite analogue signal and output means arranged to output the composite analogue signal for reception by a termination.

7. A system according to claim 6, in which the network is an optical network, the receiver is an optical receiver, and the converter means are arranged to clip the composite analogue signal.

8. A system according to claim 7, in which the or each optical receiver is located at a respective node remote from the termination and is arranged to transmit the reconstituted signal onwards for reception at the termination.

9. A system according to claim 7 or 8, in which the composite analogue signal has a bandwidth of one octave or less and the converter means are arranged to sample the composite analogue signal at a sampling rate below the Nyquist rate.

10. A system according to any one of claims 6 to 9, further including compression means located in the head-end station and expansion means located in the or each receiver and arranged to apply complementary compression and expansion to the composite analogue signals.

9. A method of distributing signals substantially as described with respect to the accompanying drawings.

10. A system for distributing signals substantially as described with respect to the accompanying drawings.

11. A method or system according to any one of the preceding claims, in which the signals distributed from the head-end station are television signals.

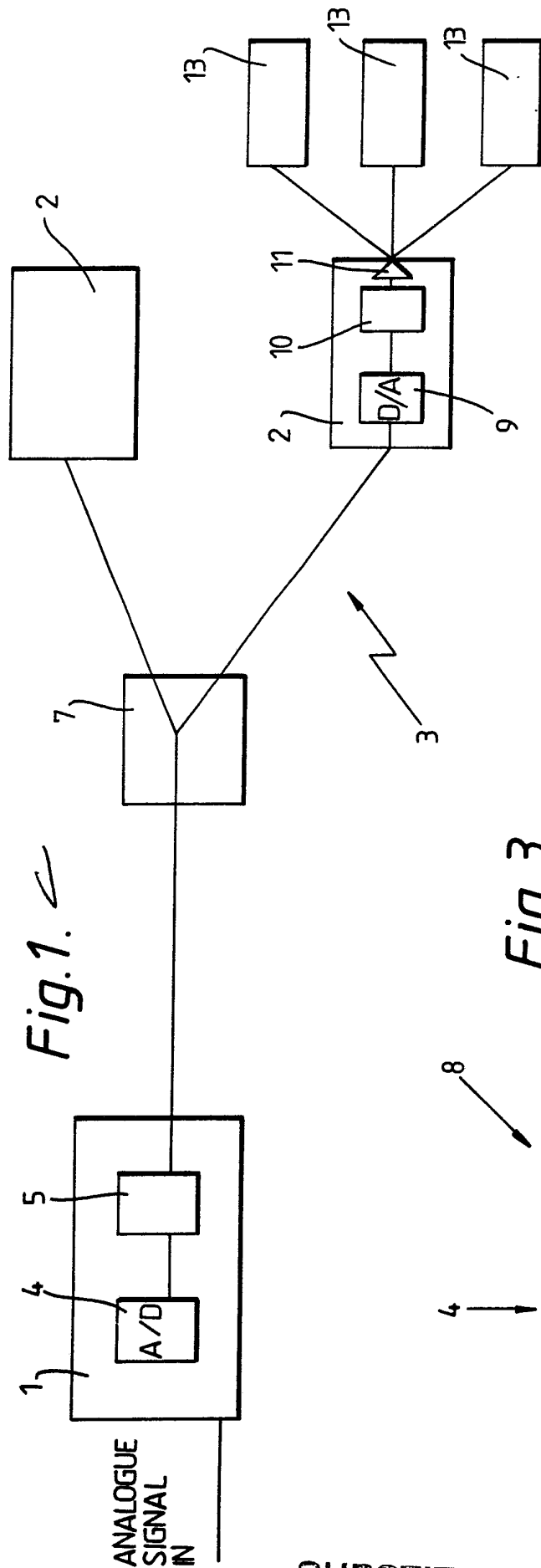

Fig. 1.

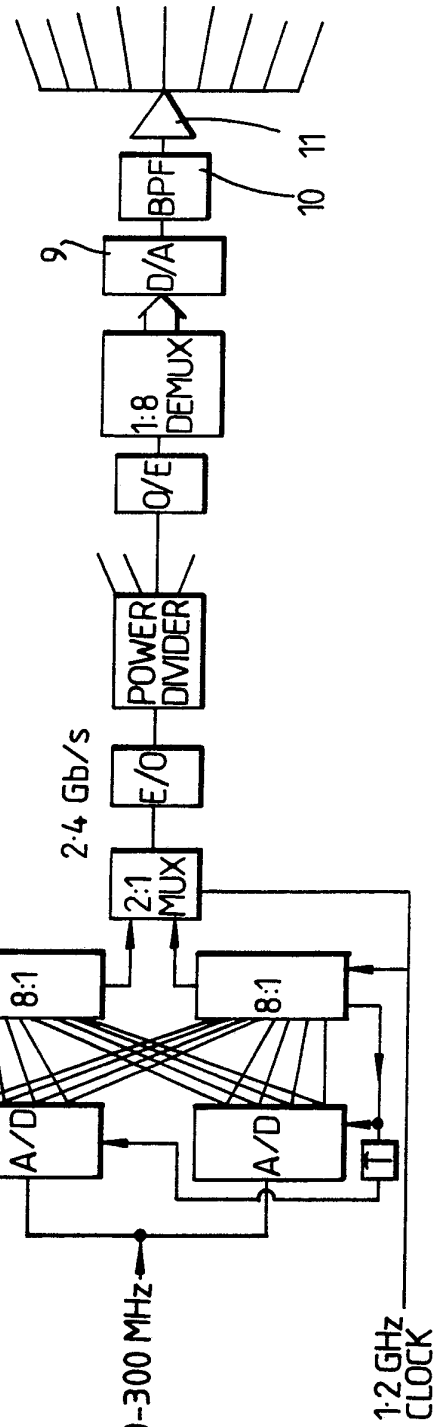

Fig. 3.

Fig. 2.

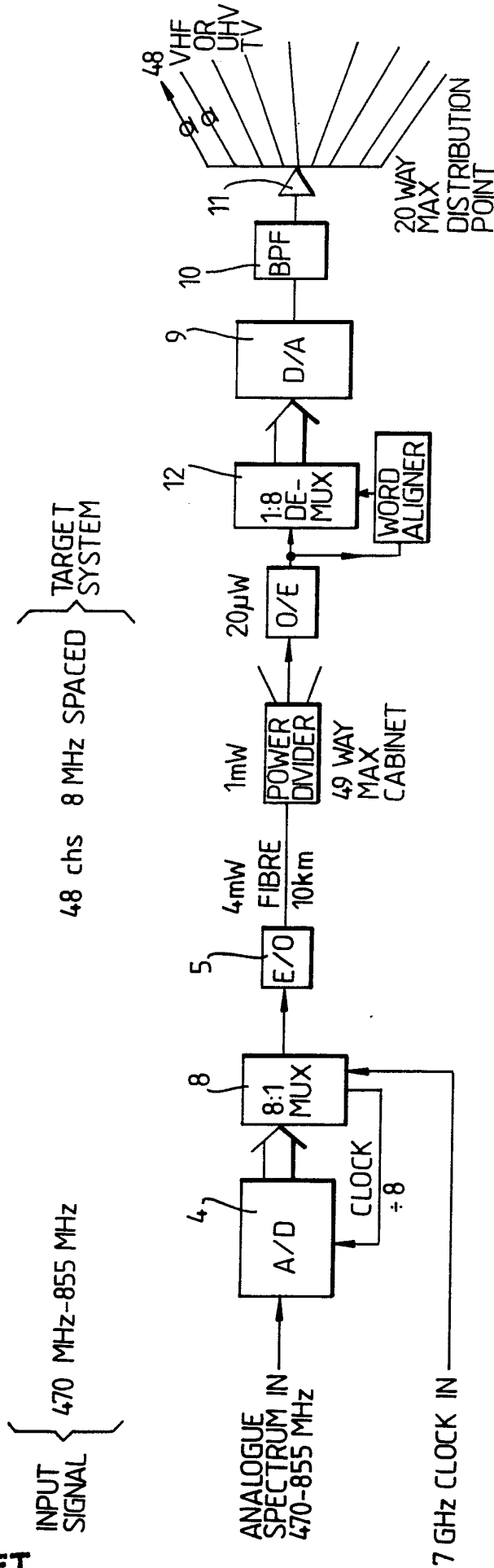
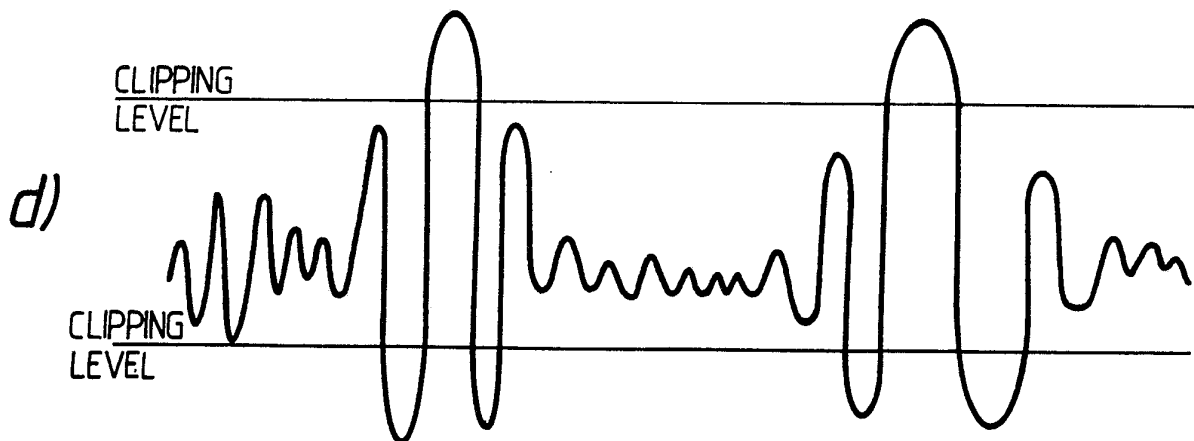
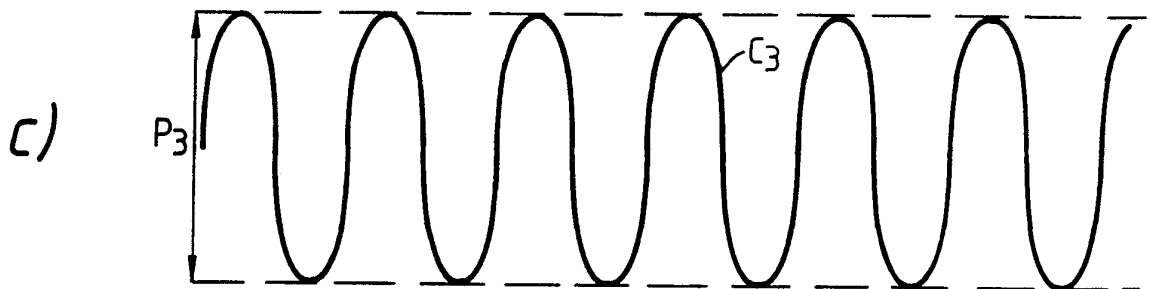
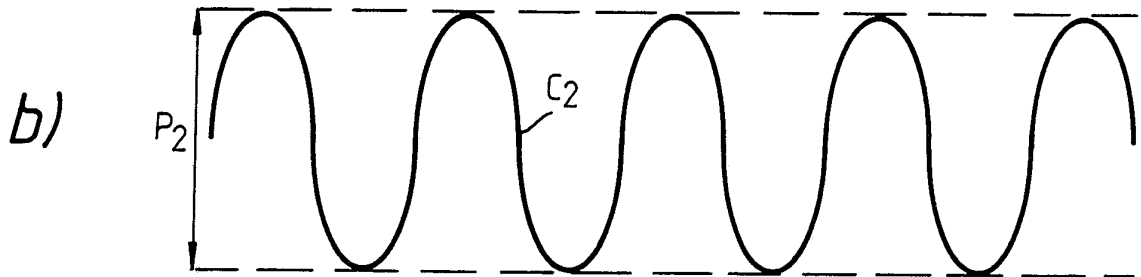
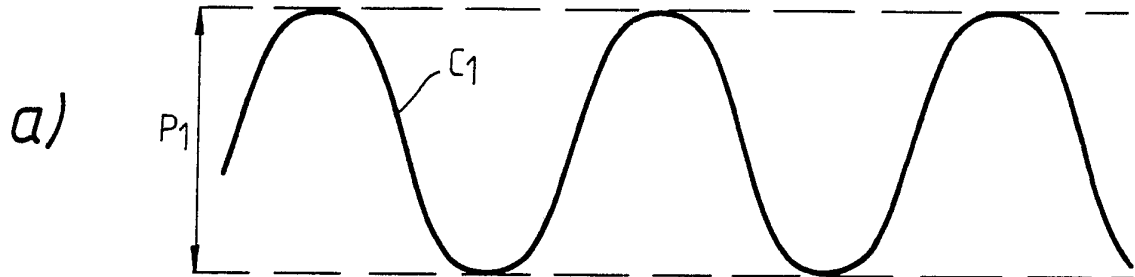

Fig.4.



INTERNATIONAL SEARCH REPORT

International Application No PCT/GB 91/00568

I. CLASSIFICATION OF SUBJECT MATTER (if several classification symbols apply, indicate all) ⁶		
According to International Patent Classification (IPC) or to both National Classification and IPC		
IPC ⁵ : H 04 N 7/22		
II. FIELDS SEARCHED		
Minimum Documentation Searched ⁷		
Classification System	Classification Symbols	
IPC ⁵	H 04 N	
Documentation Searched other than Minimum Documentation to the extent that such Documents are included in the Fields Searched ⁸		
III. DOCUMENTS CONSIDERED TO BE RELEVANT ⁹		
Category ⁹	Citation of Document, ¹¹ with indication, where appropriate, of the relevant passages ¹²	Relevant to Claim No. ¹³
A	Symposium Record, CATV sessions 16th International TV Symposium, Montreux, 17-22 June 1989, H.H. Tan et al.: "CATV distribution over a fibre optic local network", pages 262-272 see abstract; page 266, lines 1-10 ---	1,2,6-8,11
A	Funkschau, volume 62, no. 1, 29 December 1989/90, (Munich, DE), M.Gendisior et al.: "Signale auf der Glasfaser", pages 51-55 see page 54, right-hand column, line 46 - page 55, left-hand column, line 5 ---	1-3,6-8, 9-11
A	Conférence Européenne sur les Communications Optiques, Cannes, 21-24 September 1982, E. Roza et al.: "TV system with remote selection for subscriber glass fiber networks", pages 497-500 see page 499, left-hand column, lines 17-37; figure 1 ---	1-3,6-8, 9-11
./.		
<p>¹⁰ Special categories of cited documents:</p> <p>"A" document defining the general state of the art which is not considered to be of particular relevance</p> <p>"E" earlier document but published on or after the international filing date</p> <p>"L" document which may throw doubts on priority claim(s) or which is cited to establish the publication date of another citation or other special reason (as specified)</p> <p>"O" document referring to an oral disclosure, use, exhibition or other means</p> <p>"P" document published prior to the international filing date but later than the priority date claimed</p> <p>"T" later document published after the international filing date or priority date and not in conflict with the application but cited to understand the principle or theory underlying the invention</p> <p>"X" document of particular relevance; the claimed invention cannot be considered novel or cannot be considered to involve an inventive step</p> <p>"Y" document of particular relevance; the claimed invention cannot be considered to involve an inventive step when the document is combined with one or more other such documents, such combination being obvious to a person skilled in the art.</p> <p>"&" document member of the same patent family</p>		
IV. CERTIFICATION		
Date of the Actual Completion of the International Search	Date of Mailing of this International Search Report	
19th June 1991	25 JUN 1991	
International Searching Authority	Signature of Authorized Officer	
EUROPEAN PATENT OFFICE	MISS T. TAZELAAR	

III. DOCUMENTS CONSIDERED TO BE RELEVANT (CONTINUED FROM THE SECOND SHEET)		
Category *	Citation of Document, ** with indication, where appropriate, of the relevant passages	Relevant to Claim No.
A	Electronics Letters, volume 24, no. 7, 31 March 1988, (Stevenage, Herts, GB), F.V.C. Mendis et al.: "20 Km single-mode optical fibre system for multichannel video", pages 442-443 see page 442, left-hand column, lines 16-28 ---	1-4,6-11
A	Patent Abstracts of Japan, volume 10, no. 363 (E-461)(2420), 5 December 1986, & JP, A, 61158281 (MATSUSHITA ELECTRIC IND. CO. LTD.) 17 July 1986 -----	1-11