



INTERNATIONAL APPLICATION PUBLISHED UNDER THE PATENT COOPERATION TREATY (PCT)

<p>(51) International Patent Classification ⁶ : A43B 13/20, 21/28, A47C 27/08</p>	<p>A1</p>	<p>(11) International Publication Number: WO 98/57560 (43) International Publication Date: 23 December 1998 (23.12.98)</p>
<p>(21) International Application Number: PCT/US97/16928 (22) International Filing Date: 25 September 1997 (25.09.97) (30) Priority Data: 08/876,494 16 June 1997 (16.06.97) US (71)(72) Applicants and Inventors: HUANG, Ing, Chung [-/-]; No. 218 Cheng Kong Three Road, Nantou City (TW). CHEN, Chung, Chin [US/US]; 5505 Miles Court, Springfield, VA 22151 (US). (74) Agents: KENNEY, J., Ernest et al.; Bacon & Thomas, 4th floor, 625 Slaters Lane, Alexandria, VA 22314 (US).</p>		<p>(81) Designated States: AL, AM, AT, AU, AZ, BA, BB, BG, BR, BY, CA, CH, CN, CU, CZ, DE, DK, EE, ES, FI, GB, GE, GH, HU, ID, IL, IS, JP, KE, KG, KP, KR, KZ, LC, LK, LR, LS, LT, LU, LV, MD, MG, MK, MN, MW, MX, NO, NZ, PL, PT, RO, RU, SD, SE, SG, SI, SK, SL, TJ, TM, TR, TT, UA, UG, UZ, VN, YU, ZW, ARIPO patent (GH, KE, LS, MW, SD, SZ, UG, ZW), Eurasian patent (AM, AZ, BY, KG, KZ, MD, RU, TJ, TM), European patent (AT, BE, CH, DE, DK, ES, FI, FR, GB, GR, IE, IT, LU, MC, NL, PT, SE), OAPI patent (BF, BJ, CF, CG, CI, CM, GA, GN, ML, MR, NE, SN, TD, TG).</p> <p>Published <i>With international search report.</i></p>

(54) Title: SELF-INFLATABLE AIR CUSHION

(57) Abstract

A self-inflatable air cushion (1a) which includes a support chamber (1) mounted in a sole (6) of a shoe and holding a liquid, a collapsible plenum chamber (10) surrounded by the support chamber (1) and partially protruding over the top of the sole (6) and having a top air hole (31), passage means (22, 33) connected between the support chamber (1) and the plenum chamber (10), and one-way valve (101) mounted in the passage means (22, 33) to let flow move in one direction from the plenum chamber (10) to the support chamber (1) upon compression of the plenum chamber (10).

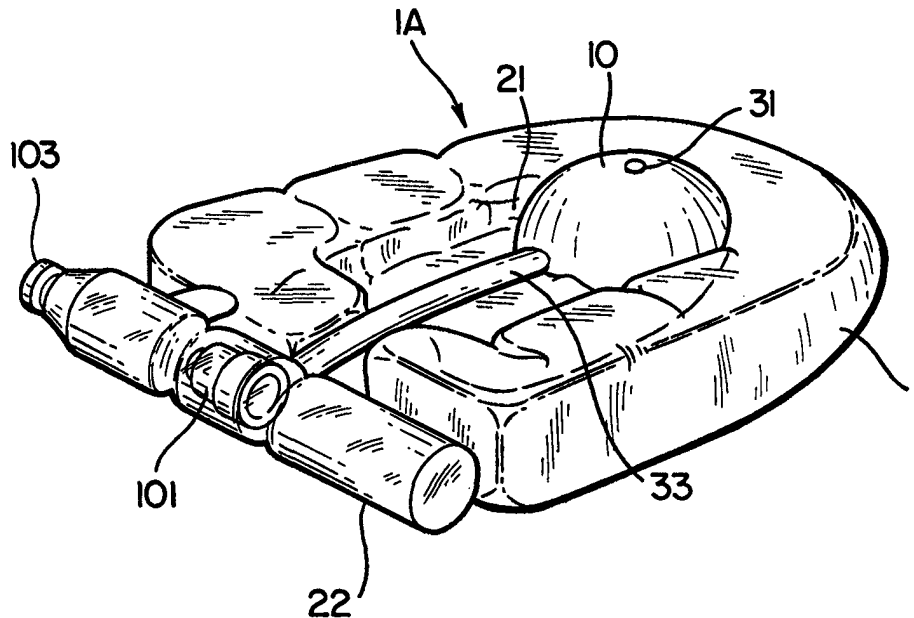

FOR THE PURPOSES OF INFORMATION ONLY

Codes used to identify States party to the PCT on the front pages of pamphlets publishing international applications under the PCT.

AL	Albania	ES	Spain	LS	Lesotho	SI	Slovenia
AM	Armenia	FI	Finland	LT	Lithuania	SK	Slovakia
AT	Austria	FR	France	LU	Luxembourg	SN	Senegal
AU	Australia	GA	Gabon	LV	Latvia	SZ	Swaziland
AZ	Azerbaijan	GB	United Kingdom	MC	Monaco	TD	Chad
BA	Bosnia and Herzegovina	GE	Georgia	MD	Republic of Moldova	TG	Togo
BB	Barbados	GH	Ghana	MG	Madagascar	TJ	Tajikistan
BE	Belgium	GN	Guinea	MK	The former Yugoslav Republic of Macedonia	TM	Turkmenistan
BF	Burkina Faso	GR	Greece	ML	Mali	TR	Turkey
BG	Bulgaria	HU	Hungary	MN	Mongolia	TT	Trinidad and Tobago
BJ	Benin	IE	Ireland	MR	Mauritania	UA	Ukraine
BR	Brazil	IL	Israel	MW	Malawi	UG	Uganda
BY	Belarus	IS	Iceland	MX	Mexico	US	United States of America
CA	Canada	IT	Italy	NE	Niger	UZ	Uzbekistan
CF	Central African Republic	JP	Japan	NL	Netherlands	VN	Viet Nam
CG	Congo	KE	Kenya	NO	Norway	YU	Yugoslavia
CH	Switzerland	KG	Kyrgyzstan	NZ	New Zealand	ZW	Zimbabwe
CI	Côte d'Ivoire	KP	Democratic People's Republic of Korea	PL	Poland		
CM	Cameroon	KR	Republic of Korea	PT	Portugal		
CN	China	KZ	Kazakstan	RO	Romania		
CU	Cuba	LC	Saint Lucia	RU	Russian Federation		
CZ	Czech Republic	LI	Liechtenstein	SD	Sudan		
DE	Germany	LK	Sri Lanka	SE	Sweden		
DK	Denmark	LR	Liberia	SG	Singapore		
EE	Estonia						

SELF-INFLATABLE AIR CUSHION

BACKGROUND OF THE INVENTION

The present invention relates to a self-inflatable air cushion for use in shoes, and more particularly to such a self-inflatable air cushion which comprises a collapsible plenum chamber, a support chamber, and an one-way valve connected between the plenum chamber and the support chamber for permitting air be driven from the collapsible plenum into the support chamber by compressing the plenum chamber with the foot.

A regular air cushion for shoes is generally comprised of a collapsible three-dimensional body defining a plurality of air cells and a plurality of passages connected between the air cells, and an air valve connected to the passages and disposed outside the sole of the shoe. When the air cushion is interlude, an air pump is attached to the air valve and operated to pump air into the air cells. If the inside pressure of the air cushion is excessively high, it cannot be regulated.

SUMMARY OF THE INVENTION

According to one aspect of the present invention, the self-inflatable air cushion comprises a support chamber, a collapsible plenum chamber surrounded by the support chamber and having an air hole, an air passage communicating between the

support chamber and the collapsible plenum chamber, an one-way valve mounted in the air passage which permits air to pass from the plenum chamber to the support chamber. When the plenum chamber is compressed with the foot, air is forced out of the plenum chamber through the one-way valve into the support chamber. When the plenum chamber is released, outside air is drawn into the plenum chamber through its air hole. According to another aspect of the present invention, a relief valve or pressure regulating chamber is provided to regulate the inside pressure of the support chamber to the desired level. According to still another aspect of the present invention, a pressure accumulation chamber is provided having one end connected to the plenum chamber through an one-way valve, which permits air to flow from the plenum chamber to the pressure accumulation chamber, and an opposite end connected to the support chamber through an one-way valve, which permits air to flow from the pressure accumulation chamber to the support chamber. When the plenum chamber is compressed, air pressure is driven from the plenum chamber into the pressure accumulation chamber. However, because the support chamber simultaneously receives an external pressure, the air pressure of the pressure accumulation chamber is stopped from passing to the support chamber. When the external pressure is released from the support chamber, the air pressure of the pressure

accumulation chamber is allowed to pass to the inside of the support chamber.

BRIEF DESCRIPTION OF THE DRAWINGS

Fig. 1 is an elevational view of a self-inflatable air cushion
5 according to one embodiment of the present invention;

Fig. 2 is an elevational view of a self-inflatable air cushion according to an alternate form of the present invention;

Fig. 3 is an applied view of the present invention, showing the self-inflatable air cushion mounted in an insole of a shoe and
10 operated;

Fig. 4 is a plain view showing another alternate form of the present invention;

Fig. 4A is a sectional view taken along line 10A-10A of Figure 4;

15 Fig. 4B shows the turning direction of the plenum chamber of the embodiment shown in Figure 4;

Fig. 4C shows the plenum chamber of the embodiment of Figure 4 arranged in the top recess of the corresponding support chamber;

20 Fig. 4D is a sectional view taken along line 10D-10D of Figure 4;

Fig. 5 is a sectional view of still another alternate form of the present invention, showing the installation of the pressure

regulating rod in the pressure regulating chamber; and

Fig. 5A is a sectional view taken along line 11A-11A.

DETAILED DESCRIPTION OF THE PREFERRED EMBODIMENTS

Referring to Figure 1, a self-inflatable air cushion 1a is shown comprising a support chamber 1, an open space 21 surrounded by the air chamber 1, a plenum chamber 10 disposed in the open space 21 and having an air hole 31, an air cylinder 22 having its one end, namely, the rear end disposed in communication with the support chamber 1, a connecting tube 33 connected between the plenum chamber 10 and the air cylinder 22, an one-way valve 101 mounted in the air cylinder 22 which permits air to pass from the plenum chamber 10 through the air cylinder 22 to the inside of the support chamber 1, and a relief valve 103 mounted in one end, namely, the front end of the air cylinder 22.

Figure 2 shows an alternate form of the present invention. According to this alternate form, the air cushion 1 comprises a support chamber 1, an air cylinder 22 connected to the support chamber 1 at one side, a plenum chamber 10 spaced from the air cylinder 22 at one side opposite to the support chamber 1, and a connecting tube 34 connected between one end, namely, the rear end of the air cylinder 22 and the plenum chamber 10, an one-way valve 101 mounted in the air cylinder 22 for permitting air to be delivered from the plenum chamber 10 to the support chamber 1.

and a relief valve 103 mounted in one end, namely, the front end of the air cylinder 22.

Referring to Figure 3, the air cushion 1A is mounted inside an insole 6 of a shoe with the plenum chamber 10 projecting out of a top hole 61 of the insole 6 at the heel area. When the user's foot is stepped on the plenum chamber 10, the plenum chamber 10 is collapsed, and the inside pressure of the plenum chamber 10 is forced through the connecting tube 33 and the air cylinder 22 into the support chamber 1. When the user's foot is lifted from the collapsed plenum chamber 10, outside air is immediately drawn into the plenum chamber 10 due to an air pressure difference between the inside pressure of the plenum chamber 10 and the atmospheric pressure. When the user continuously steps on the plenum chamber 1 of the air cushion 1A, the support chamber 1 will be inflated to the saturated status. When the support chamber 1 is fully inflated, the support chamber 1 supports the plenum chamber 10 against outside pressure. Further, through the relief valve 103, the user can adjust the pressure of the support chamber 1 to the desired level.

Referring to Figure 4, outside air passes from the air hole 31 into the plenum chamber 10. When the user's foot gives a pressure to the plenum chamber 10, the air hole 31 is stopped by the user's foot and the inside air of the plenum chamber 10 is

forced by the pressure of the user's foot to flow through an air passage 3b to a pressure regulating chamber 301 and then through the aforesaid one-way valve 101 to a pressure accumulation chamber 6. The pressure accumulation chamber 6 is arranged at a place in which the pressure accumulation chamber 6 bears no pressure when the support chamber 1 or the plenum chamber 10 receives a pressure from the user's foot, therefore, compressed air is allowed to be forced out of the plenum chamber 10 into the pressure accumulation chamber 6 and then through an one-way valve 102 into the support chamber 1 via an air passage 3a.

Referring to Figures 4B, 4C and 4D, the plenum chamber 10 can be turned backwards through about 180° and arranged in a top recess 10a of the support chamber 1 with its air hole 31 facing upwards.

Referring to Figures 5 and 5A, a pressure regulating rod 301 is mounted in a pressure regulating chamber 301. The pressure regulating rod 301 is a hollow rod having a longitudinal center hole 52, a plurality of recessed holes 54, and a plurality of radial through holes 52 in communication with the longitudinal center hole 52. The recessed holes 54 and the through holes 52 are arranged corresponding to distribution chambers 51, the one-way valve 101, and an air passage 3a. By turning the pressure regulating rod 301, the pressure of the pressure accumulation

chamber 6 and the support chamber 1 is regulated. When the through holes 52 are moved away from the air passage 3a, compressed air is prohibited to pass from the penned chamber 10 to the support chamber 1. When the air passage 3a, the through holes 52 and the distribution chambers 51 are set into communication with one another through the longitudinal center hole 53, air pressure is allowed to pass into the pressure accumulation chamber 6 subject to the volume of the distribution chambers 51. Assume the inside volume of the penned chamber 10 = A, the inside volume of the distribution chambers 51 = B, the inside volume of the plenum chamber 10 when collapsed = C, thus $P_1V_1 * P_2V_2 = n$, the pressure of the plenum chamber 10 after compressed is $P_b = P_a A / (B + C)$, therefore when the greater the inside volume B of the distribution chambers 51, the smaller the air pressure P_b of the pressure accumulation chamber 6 will be.

When the through holes 52 and the plenum chamber 10 are disposed in communication with an air passage 3c, air is allowed to be squeezed out of the plenum chamber 10 through the air passage 3c to other air circulation area. Therefore, the air cushion 1A can also improve the ventilation of the shoe.

It is to be understood that the drawings are designed for purposes of illustration only, and are not intended as a definition of the limits and scope of the invention disclosed.

What the invention claimed is:

1. A self-inflatable air cushion comprising:
a support chamber having a three-dimensional body surrounding an open space and adapted for holding a liquid;
5 a hollow collapsible plenum chamber having a variable volume which is changed when said plenum chamber is collapsed;
passage means connected between said support chamber and said plenum chamber; and
one-way valve means mounted in said passage means to let
10 flow move in one direction from said plenum chamber to said support chamber.
2. The self-inflatable air cushion of claim 1, wherein said plenum chamber is mounted in said open space surrounded by said support chamber.
- 15 3. The self-inflatable air cushion of claim 1, wherein said plenum chamber is disposed outside said open space and spaced from said support chamber at a distance.
4. The self-inflatable air cushion of claim 1, wherein said plenum chamber has an air hole at a top side thereof.
- 20 5. The self-inflatable air cushion of claim 1 further comprising relief valve means mounted in said passage means and controlled to release pressure from said support chamber.

6. The self-inflatable air cushion of claim 1 further comprising a pressure regulating chamber disposed in communication between said plenum chamber and said support chamber and controlled to regulate the inside pressure of said
5 support chamber.

7. The self-inflatable air cushion of claim 6, wherein said pressure regulating chamber comprises a pressure regulating rod controlled to regulate the inside pressure of said support chamber.

8. The self-inflatable air cushion of claim 7, wherein said
10 pressure regulating chamber is connected to at least one air distribution chamber.

9. A self-inflatable air cushion comprising:

a support chamber having a three-dimensional body adapted for holding a liquid and a top recess at said three-
15 dimensional body for receiving a plenum chamber;

a hollow collapsible plenum chamber having a variable volume which is changed when said plenum chamber is collapsed;

passage means connected between said support chamber and said plenum chamber;

20 one-way valve means mounted in said passage means to let flow move in one direction from said plenum chamber to said support chamber; and

at least one pressure accumulation chamber connected between said plenum chamber and said support chamber.

10. The self-inflatable air cushion of claim 9 further comprising a pressure regulating chamber connected between said
5 plenum chamber and said at least one pressure accumulation chamber and controlled to regulate the inside pressure of said support chamber.

11. The self-inflatable air cushion of claim 10, wherein said pressure regulating chamber comprises a pressure regulating
10 rod controlled to regulate the inside pressure of said support chamber.

12. The self-inflatable air cushion of claim 10, wherein said pressure regulating chamber is connected to at least one air
distribution chamber.

15 13. The self-inflatable air cushion of claim 9, wherein said plenum chamber has an air hole.

14. The self-inflatable air cushion of claim 9, wherein said plenum chamber is mounted in an open space surrounded by said
support chamber.

20 15. The self-inflatable air cushion of claim 9, wherein said plenum chamber is disposed outside said support chamber and spaced from it at a distance by said passage means.

16. The self-inflatable air cushion of claim 9, wherein said

plenum chamber comprises at least one-way valve through which outside air is drawn into said plenum chamber.

FIG. 1

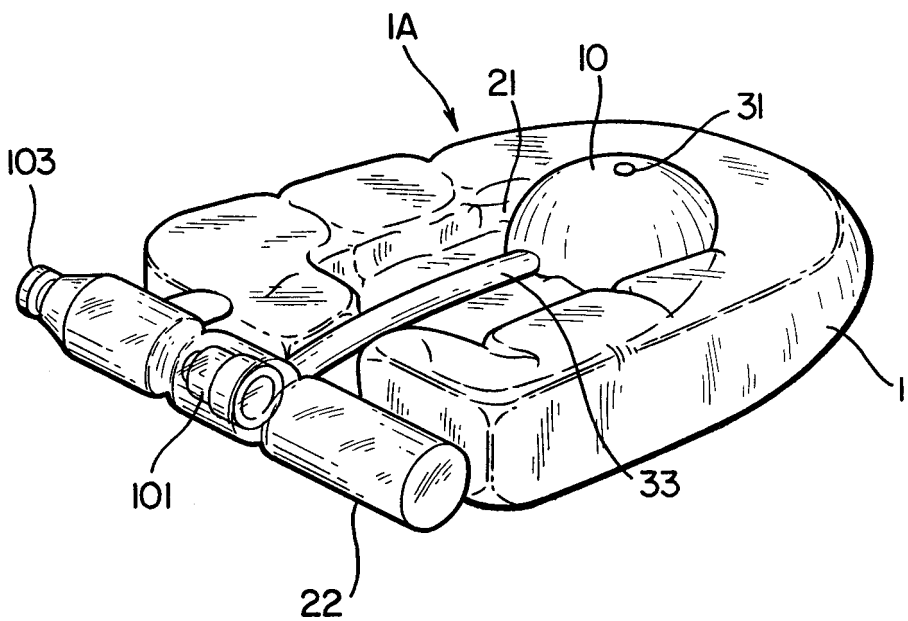
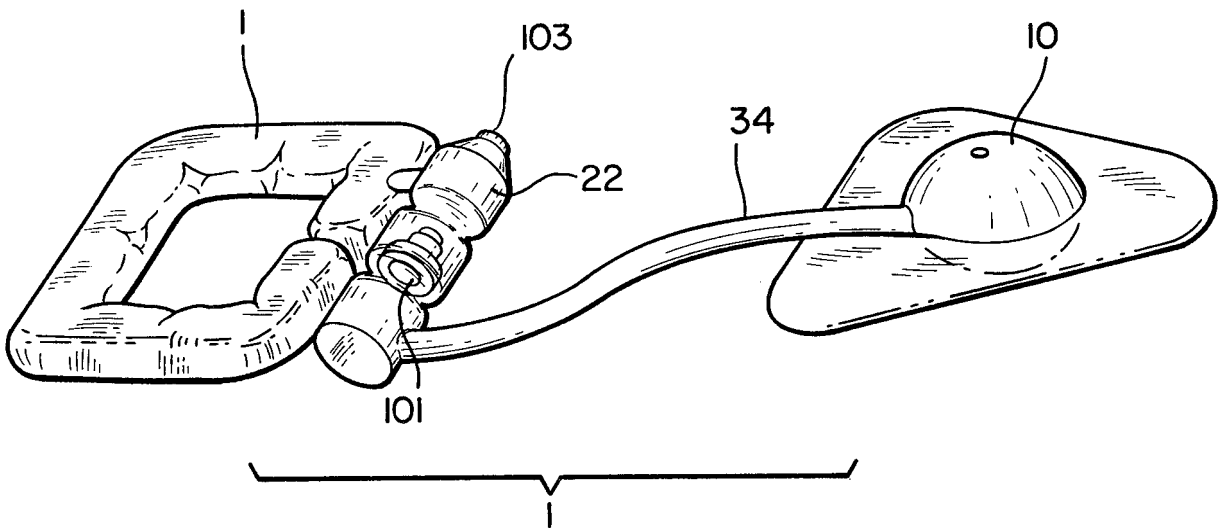

FIG. 2



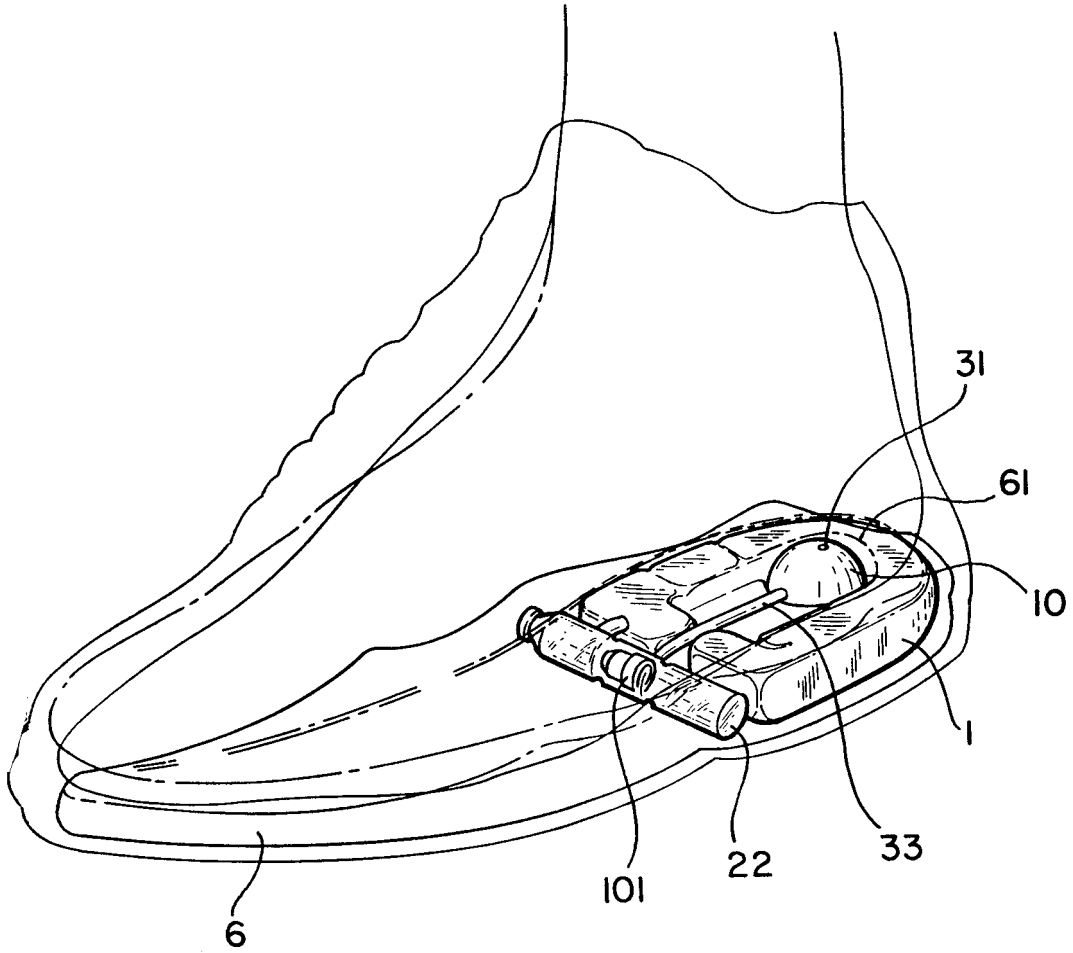

FIG. 3

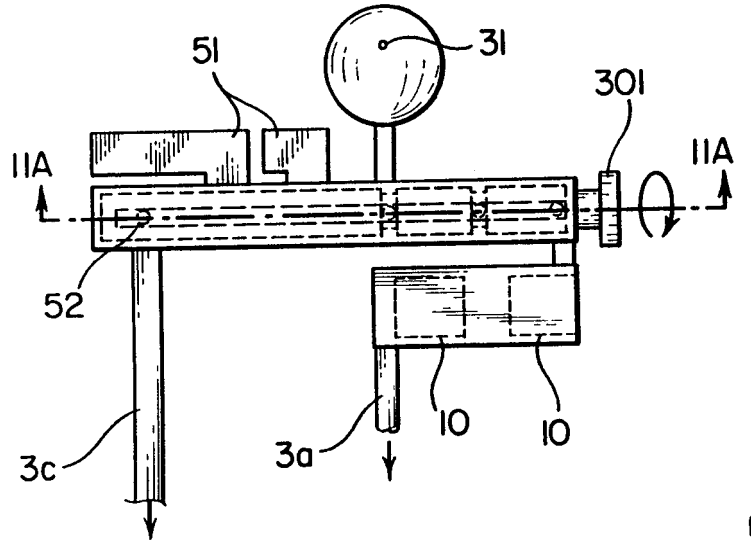

FIG. 5

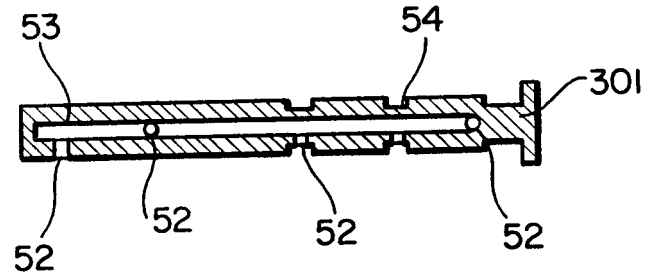
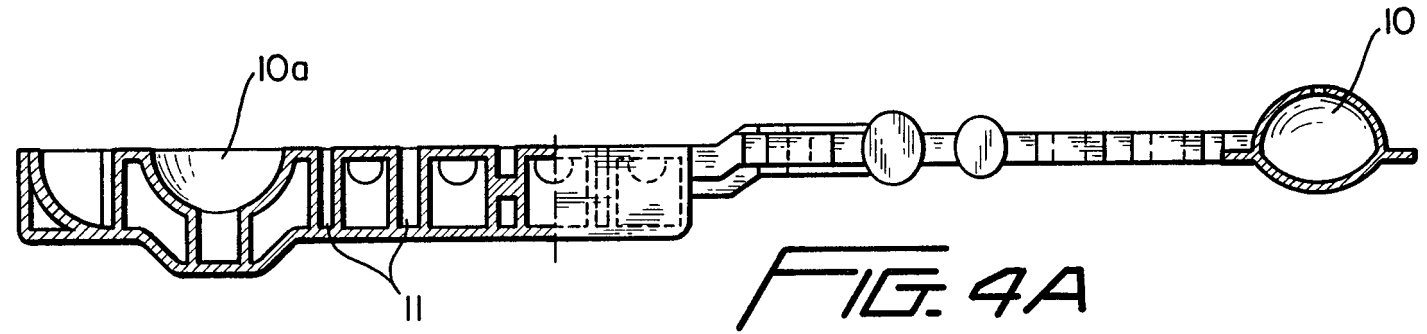
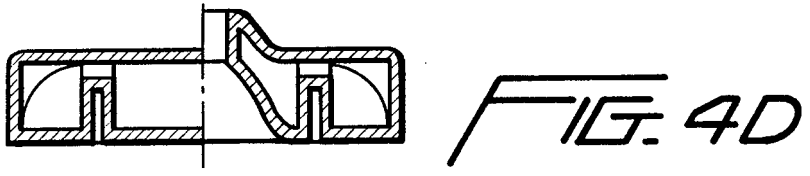
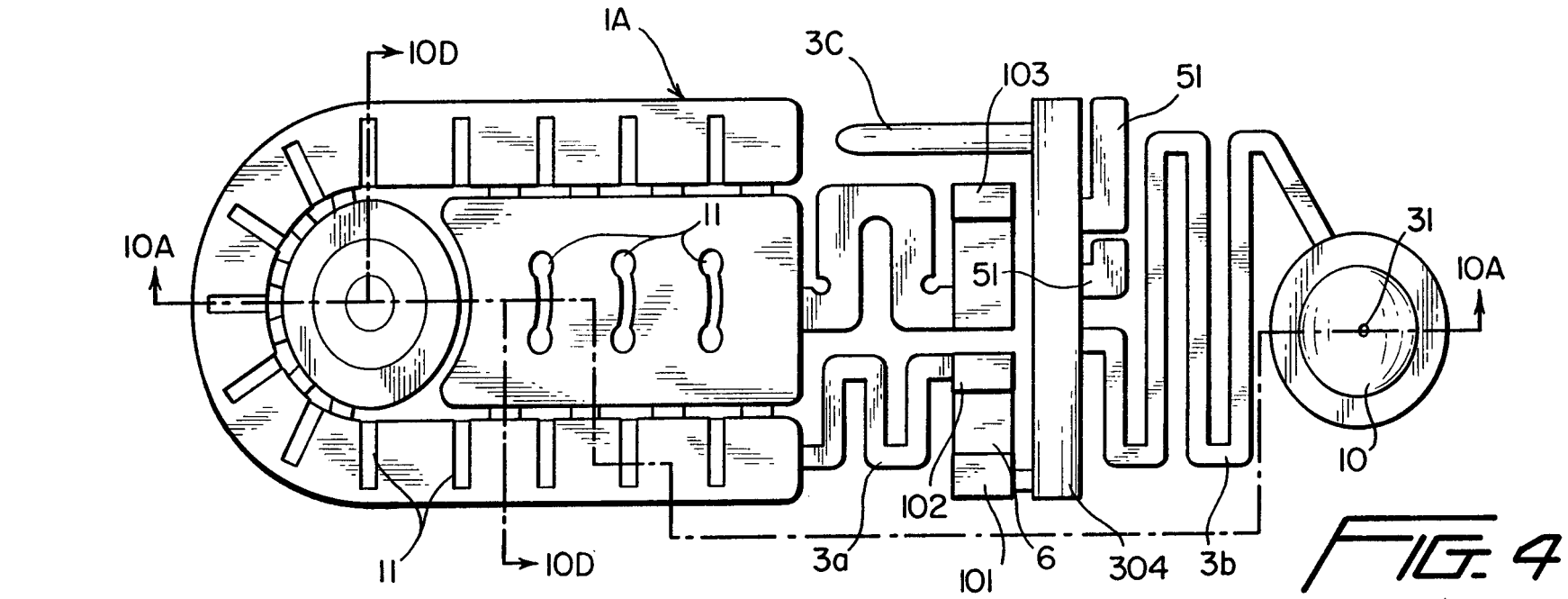

FIG. 5A



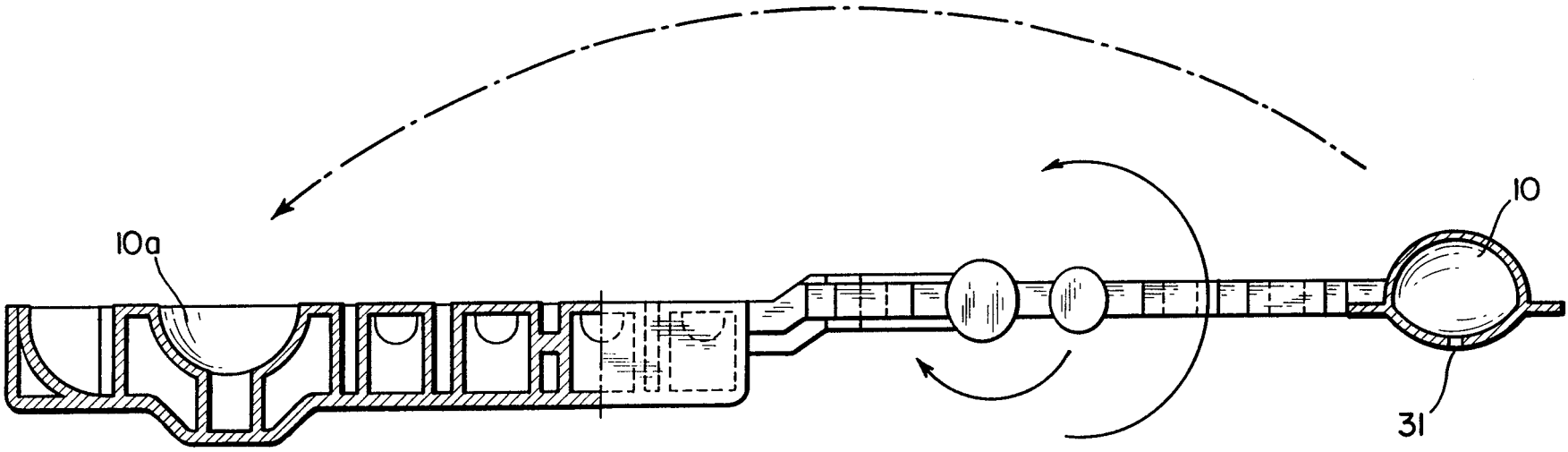

FIG. 4B

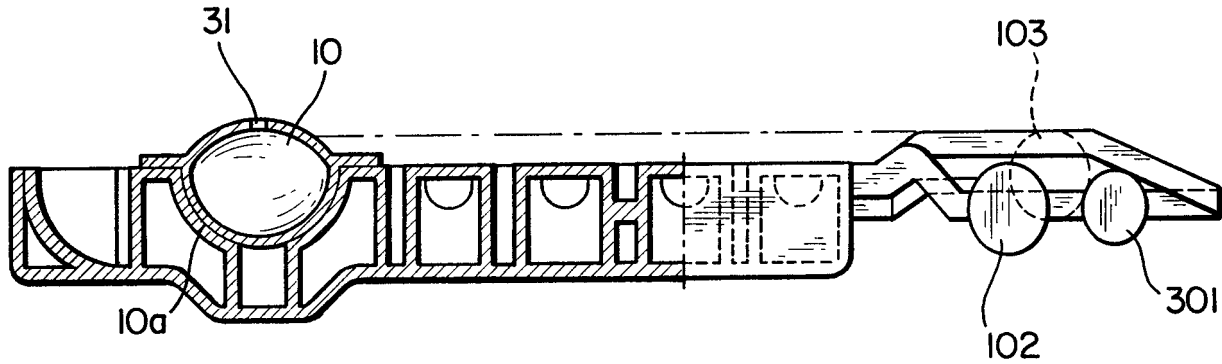

FIG. 4C

INTERNATIONAL SEARCH REPORT

International application No.
PCT/US97/16928

A. CLASSIFICATION OF SUBJECT MATTER

IPC(6) :A43B 13/20, 21/28; A47C 27/08
US CL :5/655.3, 654; 36/29, 35B

According to International Patent Classification (IPC) or to both national classification and IPC

B. FIELDS SEARCHED

Minimum documentation searched (classification system followed by classification symbols)

U.S. : 5/655.3, 655.5, 654, 708; 36/29, 35B, 35R, 71, 3B

Documentation searched other than minimum documentation to the extent that such documents are included in the fields searched

Electronic data base consulted during the international search (name of data base and, where practicable, search terms used)

C. DOCUMENTS CONSIDERED TO BE RELEVANT

Category*	Citation of document, with indication, where appropriate, of the relevant passages	Relevant to claim No.
X --- Y	US 5,335,382 A (HUANG) 9 August 1994 (09/08/94), column 5, lines 38-64.	1-3, 5-16 ----- 4
Y	US 4,763,426 A (POLUS ET AL) 16 August 1988 (16/08/88), column 4, lines 50-58, column 5, lines 8-14.	4
A	US 5,558,395 A (HUANG) 24 September 1996 (24/09/96).	1-3, 5-16
A	US 5,406,661 A (PEKAR) 18 April 1995 (18/04/95).	1
A	US 5,222,312 A (DOYLE) 29 June 1993 (29/06/93).	1, 3-6, 9, 10, 13, 15, 16

Further documents are listed in the continuation of Box C. See patent family annex.

* Special categories of cited documents:	"T" later document published after the international filing date or priority date and not in conflict with the application but cited to understand the principle or theory underlying the invention
"A" document defining the general state of the art which is not considered to be of particular relevance	"X" document of particular relevance; the claimed invention cannot be considered novel or cannot be considered to involve an inventive step when the document is taken alone
"E" earlier document published on or after the international filing date	"Y" document of particular relevance; the claimed invention cannot be considered to involve an inventive step when the document is combined with one or more other such documents, such combination being obvious to a person skilled in the art
"L" document which may throw doubts on priority claim(s) or which is cited to establish the publication date of another citation or other special reason (as specified)	"&" document member of the same patent family
"O" document referring to an oral disclosure, use, exhibition or other means	
"P" document published prior to the international filing date but later than the priority date claimed	

Date of the actual completion of the international search 27 FEBRUARY 1998	Date of mailing of the international search report 13 MAR 1998
---	--

Name and mailing address of the ISA/US
Commissioner of Patents and Trademarks
Box PCT
Washington, D.C. 20231
Facsimile No. (703) 305-3230

Authorized officer *Robert G. Santos*
ROBERT G. SANTOS
Telephone No. (703) 308-2168

INTERNATIONAL SEARCH REPORT

International application No.

PCT/US97/16928

C (Continuation). DOCUMENTS CONSIDERED TO BE RELEVANT

Category*	Citation of document, with indication, where appropriate, of the relevant passages	Relevant to claim No.
A	US 5,195,254 A (TYNG) 23 March 1993 (23/03/93).	4, 13
A	US 4,446,634 A (JOHNSON ET AL) 08 May 1984 (08/05/84).	1, 3, 5, 15
A	US 3,583,008 A (EDWARDS) 08 June 1971 (08/06/71).	1, 3, 15
A	GB 2206475 A (MACKNESS ET AL) 11 January 1989 (11/01/89).	4, 13