

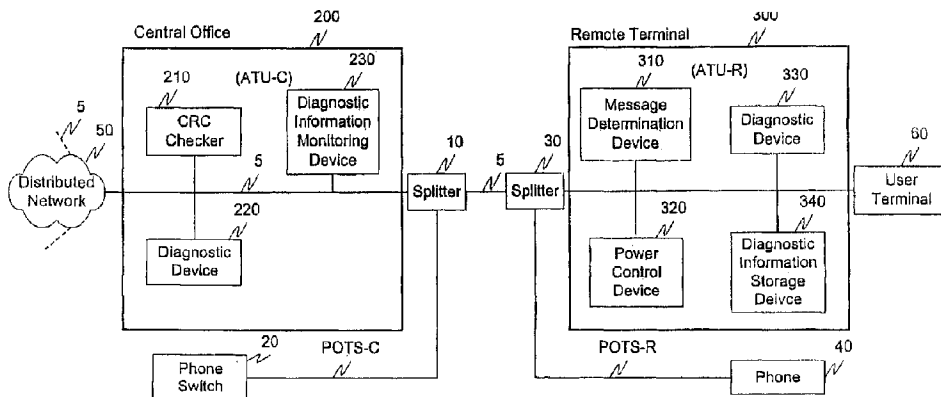

(22) **Date de dépôt/Filing Date:** 2001/01/08
(41) **Mise à la disp. pub./Open to Public Insp.:** 2001/07/19
(45) **Date de délivrance/Issue Date:** 2020/06/23
(62) **Demande originale/Original Application:** 2 788 662
(30) **Priorités/Priorities:** 2000/01/07 (US60/174,865);
2000/08/10 (US60/224,308)

(51) **Cl.Int./Int.Cl. H04B 3/46** (2015.01),
H04L 29/02 (2006.01), **H04M 11/06** (2006.01)
(72) **Inventeurs/Inventors:**
KRINSKY, DAVID M., US;
PIZZANO, ROBERT EDMUND, JR., US
(73) **Propriétaire/Owner:**
TQ DELTA, LLC, US
(74) **Agent:** SMART & BIGGAR LLP

(54) **Titre : SYSTEMES ET PROCEDES POUR ETABLIR UN MODE DE TRANSMISSION DIAGNOSTIQUE ET COMMUNIQUER PAR L'INTERMEDIAIRE DE CELUI-CI**
(54) **Title: DIAGNOSTIC METHODS AND SYSTEMS FOR MULTICARRIER MODEMS**



(57) **Abrégé/Abstract:**

Upon detection of a trigger, such as the exceeding of an error threshold or the direction of a user, a diagnostic link system enters a diagnostic information transmission mode. This diagnostic information transmission mode allows for two modems to exchange diagnostic and/or test information that may not otherwise be exchangeable during normal communication. The diagnostic information transmission mode is initiated by transmitting an initiate diagnostic link mode message to a receiving modem accompanied by a cyclic redundancy check (CRC). The receiving modem determines, based on the CRC, if a robust communications channel is present. If a robust communications channel is present, the two modems can initiate exchange of the diagnostic and/or test information. Otherwise, the transmission power of the transmitting modem is increased and the initiate diagnostic link mode message re-transmitted to the receiving modem until the CRC is determined to be correct.

Abstract

Upon detection of a trigger, such as the exceeding of an error threshold or the direction of a user, a diagnostic link system enters a diagnostic information transmission mode. This diagnostic information transmission mode allows for two modems to exchange diagnostic and/or test information that may not otherwise be exchangeable during normal communication. The diagnostic information transmission mode is initiated by transmitting an initiate diagnostic link mode message to a receiving modem accompanied by a cyclic redundancy check (CRC). The receiving modem determines, based on the CRC, if a robust communications channel is present. If a robust communications channel is present, the two modems can initiate exchange of the diagnostic and/or test information. Otherwise, the transmission power of the transmitting modem is increased and the initiate diagnostic link mode message re-transmitted to the receiving modem until the CRC is determined to be correct.

DIAGNOSTIC METHODS AND SYSTEMS FOR MULTICARRIER MODEMS**Related Applications**

This is a divisional application of Canadian Patent application serial no.
5 2,726,826 which is a divisional application of Canadian Patent application serial no. 2,394,491
having an effective filing date of January 8, 2001.

Field of the Invention

This invention relates to test and diagnostic information. In particular, this
10 invention relates to a robust system and method for communicating diagnostic information.

Background of the Invention

The exchange of diagnostic and test information between transceivers in a
telecommunications environment is an important part of a telecommunications, such as an
15 ADSL, deployment. In cases where the transceiver connection is not performing as expected,
for example, where the data rate is low, where there are many bit errors, or the like, it is
necessary to collect diagnostic and test information from the remote transceiver. This is
performed by dispatching a technician to the remote site, e.g., a truck roll, which is time
consuming and expensive.

20 In DSL technology, communications over a local subscriber loop between a
central office and a subscriber premises is accomplished by modulating the data to be
transmitted on to a multiplicity of discrete frequency carriers which are summed together and
then transmitted over the subscriber loop. Individually, the carriers form discrete, non-
overlapping communication subchannels of limited bandwidth. Collectively, the carriers form
25 what is effectively a broadband communications channel. At the receiver end, the carriers are
demodulated and the data recovered.

DSL systems experience disturbances from other data services on adjacent
phone lines, such as, for example, ADSL, HDSL, ISDN, Ti, or the like. These disturbances
may commence after the subject ADSL service is already initiated and, since DSL for internet
30 access is envisioned as an always-on service, the effect of these disturbances must be
ameliorated by the subject ADSL transceiver.

SUMMARY OF THE INVENTION

In accordance with one aspect of the present invention, there is provided, in a multicarrier modulation transceiver, a method of communicating diagnostic information over a communication channel using multicarrier modulation comprising: transmitting or receiving at the multicarrier modulation transceiver an initiate diagnostic mode message; and transmitting from the multicarrier modulation transceiver a diagnostic message using multicarrier modulation, wherein the diagnostic message comprises a plurality of data variables representing the diagnostic information about the communication channel and each bit in the diagnostic message is mapped to at least one Discrete Multitone (DMT) symbol, and wherein one variable comprises an array representing frequency domain received idle channel noise information.

In accordance with another aspect of the present invention, there is provided a diagnostic system capable of communicating diagnostic information over a communication channel using multicarrier modulation comprising: a transceiver capable of transmitting or receiving an initiate diagnostic mode message; and a message determination module capable of determining and, in cooperation with the transceiver, transmitting a diagnostic message from the transceiver, wherein the diagnostic message comprises a plurality of data variables representing the diagnostic information about the communication channel and each bit in the diagnostic message is mapped to at least one DMT signal, and wherein one variable comprises an array representing frequency domain received idle channel noise information.

In accordance with another aspect of the present invention, there is provided a multicarrier communication transceiver capable of communicating diagnostic information over a communication channel using multicarrier modulation comprising: means for transmitting or receiving at the multicarrier communication transceiver an initiate diagnostic mode message; and means for transmitting from the multicarrier communication transceiver a diagnostic message using multicarrier modulation, wherein the diagnostic message comprises a plurality of data variables representing the diagnostic information about the communication channel and each bit in the diagnostic message is mapped to at least one DMT symbol, and wherein one variable comprises an array representing frequency domain received idle channel noise information.

In accordance with another aspect of the present invention, there is provided, in a multicarrier communication transceiver, a protocol for communicating diagnostic information over a communication channel using multicarrier modulation comprising: transmitting or receiving at the multicarrier communication transceiver an initiate diagnostic mode message;

and transmitting from the multicarrier communication transceiver a diagnostic message using multicarrier modulation, wherein the diagnostic message comprises a plurality of data variables representing the diagnostic information about the communication channel and each bit in the diagnostic message is mapped to at least one DMT symbol, and wherein one variable
5 comprises an array representing frequency domain received idle channel noise information.

In accordance with another aspect of the present invention, there is provided an information storage media comprising instructions that when executed communicate diagnostic information over a communication channel using multicarrier modulation comprising:
instructions that when executed direct a transceiver to receive or transmit an initiate diagnostic
10 mode message; and instructions that when executed transmit a diagnostic message from the transceiver using multicarrier modulation, wherein the diagnostic message comprises a plurality of data variables representing the diagnostic information about the communication channel and each bit in the diagnostic message is mapped to at least one DMT symbol, and wherein one variable comprises an array representing frequency domain received idle channel
15 noise information.

In accordance with another aspect of the present invention, there is provided, in a multicarrier modulation transceiver, a method of communicating diagnostic information over a communication channel using multicarrier modulation comprising: transmitting or receiving
at the multicarrier modulation transceiver an initiate diagnostic mode message; and transmitting
20 from the multicarrier modulation transceiver a diagnostic message using multicarrier modulation with DMT symbols that are mapped to one bit of the diagnostic message, wherein the diagnostic message comprises a plurality of data variables representing the diagnostic information about the communication channel, and wherein one variable comprises an array representing frequency domain received idle channel noise information.

In accordance with another aspect of the present invention, there is provided a diagnostic system capable of communicating diagnostic information over a communication channel using multicarrier modulation comprising: a transceiver capable of transmitting or receiving an initiate diagnostic mode message; and a message determination module capable of determining and, in cooperation with the transceiver, transmitting from the transceiver a
25 diagnostic message using multicarrier modulation with DMT symbols that are mapped to one
30 bit of the diagnostic message, wherein the diagnostic message comprises a plurality of data variables representing the diagnostic information about the communication channel, and

wherein one variable comprises an array representing frequency domain received idle channel noise information.

In accordance with another aspect of the present invention, there is provided a multicarrier communication transceiver capable of communicating diagnostic information over a communication channel using multicarrier modulation comprising: means for transmitting or receiving at the multicarrier communication transceiver an initiate diagnostic mode message; and means for transmitting from the multicarrier communication transceiver a diagnostic message using multicarrier modulation with DMT symbols that are mapped to one bit of the diagnostic message, wherein the diagnostic message comprises a plurality of data variables representing the diagnostic information about the communication channel, and wherein one variable comprises an array representing frequency domain received idle channel noise information.

In accordance with another aspect of the present invention, there is provided, in a multicarrier communication transceiver, a protocol for communicating diagnostic information over a communication channel using multicarrier modulation comprising: transmitting or receiving at the multicarrier communication transceiver an initiate diagnostic mode message; and transmitting from the multicarrier communication transceiver a diagnostic message using multicarrier modulation with DMT symbols that are mapped to one bit of the diagnostic message, wherein the diagnostic message comprises a plurality of data variables representing the diagnostic information about the communication channel, and wherein one variable comprises an array representing frequency domain received idle channel noise information.

In accordance with another aspect of the present invention, there is provided an information storage media comprising instructions that when executed communicate diagnostic information over a communication channel using multicarrier modulation comprising: instructions that when executed direct a transceiver to receive or transmit an initiate diagnostic mode message; and instructions that when executed transmit from the transceiver a diagnostic message using multicarrier modulation with DMT symbols that are mapped to one bit of the diagnostic message, wherein the diagnostic message comprises a plurality of data variables representing the diagnostic information about the communication channel, and wherein one variable comprises an array representing is frequency domain received idle channel noise information.

In accordance with another aspect of the present invention, there is provided, in a multicarrier modulation transceiver, a method of communicating diagnostic information

including a plurality of data variables over a communication channel using multicarrier modulation comprising: associating, at the transceiver in a diagnostic message and based on an initiate diagnostic mode message, each bit in the diagnostic message with at least one DMT symbol, wherein one variable comprises an array representing frequency domain received idle channel noise information.

In accordance with another aspect of the present invention, there is provided, in a multicarrier modulation transceiver, a method of communicating diagnostic information over a communication channel using multicarrier modulation comprising: transmitting, during a diagnostic mode, a diagnostic message using multicarrier modulation, wherein the diagnostic message comprises a plurality of data variables representing the diagnostic information about the communication channel and at least one bit in the diagnostic message is mapped to at least one DMT symbol, wherein one variable comprises an array representing frequency domain received idle channel noise information.

In accordance with another aspect of the present invention, there is provided communicating diagnostic information over a communication channel using multicarrier modulation comprising: communicating from a transceiver a diagnostic message comprising a plurality of data variables representing the diagnostic information, wherein each bit in the diagnostic message is mapped to at least one DMT symbol, wherein one variable comprises an array representing frequency domain received idle channel noise information.

In accordance with another aspect of the present invention, there is provided a transceiver capable of transmitting test information over a communication channel using multicarrier modulation comprising: a transmitter portion capable of transmitting a message, wherein the message comprises one or more data variables that represent the test information, wherein bits in the message are modulated onto DMT symbols using Quadrature Amplitude Modulation (QAM) with more than 1 bit per subchannel and wherein at least one data variable of the one or more data variables comprises an array representing power level per subchannel information.

In accordance with another aspect of the present invention, there is provided a transceiver capable of receiving test information over a communication channel using multicarrier modulation comprising: a receiver portion capable of receiving a message, wherein the message comprises one or more data variables that represent the test information, wherein bits in the message were modulated onto DMT symbols using Quadrature Amplitude Modulation (QAM) with more than 1 bit per subchannel and wherein at least one data variable

of the one or more data variables comprises an array representing power level per subchannel information.

In accordance with another aspect of the present invention, there is provided a transceiver capable of receiving test information over a communication channel using multicarrier modulation comprising: a receiver portion capable of receiving a message, wherein the message
5 comprises one or more data variables that represent the test information, wherein bits in the message were modulated onto DMT symbols using Quadrature Amplitude Modulation (QAM) with more than 1 bit per subchannel and wherein at least one data variable of the one or more data variables comprises an array representing power level per subchannel information.

In accordance with another aspect of the present invention, there is provided, in a transceiver capable of transmitting test information over a communication channel using multicarrier modulation, a method comprising: transmitting a message, wherein the message
10 comprises one or more data variables that represent the test information, wherein bits in the message are modulated onto DMT symbols using Quadrature Amplitude Modulation (QAM) with more than 1 bit per subchannel and wherein at least one data variable of the one or more data variables comprises an array representing power level per subchannel information.

In accordance with another aspect of the present invention, there is provided, in a transceiver capable of receiving test information over a communication channel using multicarrier modulation, a method comprising: receiving a message, wherein the message comprises one or
20 more data variables that represent the test information, wherein bits in the message were modulated onto DMT symbols using Quadrature Amplitude Modulation (QAM) with more than 1 bit per subchannel and wherein at least one data variable of the one or more data variables comprises an array representing power level per subchannel information.

In accordance with another aspect of the present invention, there is provided a non-transitory computer-readable information storage medium having stored thereon instructions that,
25 if executed, cause a transceiver to perform a method comprising: transmitting a message, wherein the message comprises one or more data variables that represent the test information, wherein bits in the message are modulated onto DMT symbols using Quadrature Amplitude Modulation (QAM) with more than 1 bit per subchannel and wherein at least one data variable of the one or
30 more data variables comprises an array representing power level per subchannel information.

In accordance with another aspect of the present invention, there is provided a transceiver capable of transmitting test information over a communication channel using multicarrier modulation comprising: a transmitter portion capable of transmitting a message, wherein the message comprises one or more data variables that represent the test information, wherein bits in the message are modulated onto DMT symbols using Quadrature Amplitude Modulation (QAM) with more than 1 bit per subchannel and wherein at least one data variable of the one or more data variables comprises an array representing Signal to Noise ratio per subchannel during Showtime information.

In accordance with another aspect of the present invention, there is provided a transceiver capable of receiving test information over a communication channel using multicarrier modulation comprising: a receiver portion capable of receiving a message, wherein the message comprises one or more data variables that represent the test information, wherein bits in the message were modulated onto DMT symbols using Quadrature Amplitude Modulation (QAM) with more than 1 bit per subchannel and wherein at least one data variable of the one or more data variables comprises an array representing Signal to Noise ratio per subchannel during Showtime information.

In accordance with another aspect of the present invention, there is provided, in a transceiver capable of transmitting test information over a communication channel using multicarrier modulation, a method comprising: transmitting a message, wherein the message comprises one or more data variables that represent the test information, wherein bits in the message are modulated onto DMT symbols using Quadrature Amplitude Modulation (QAM) with more than 1 bit per subchannel and wherein at least one data variable of the one or more data variables comprises an array representing Signal to Noise ratio per subchannel during Showtime information.

In accordance with another aspect of the present invention, there is provided, in a transceiver capable of receiving test information over a communication channel using multicarrier modulation, a method comprising: receiving a message, wherein the message comprises one or more data variables that represent the test information, wherein bits in the message were modulated onto DMT symbols using Quadrature Amplitude Modulation (QAM) with more than 1 bit per subchannel and wherein at least one data variable of the one or more data variables comprises an array representing Signal to Noise ratio per subchannel during Showtime information.

In accordance with another aspect of the present invention, there is provided a non-transitory computer-readable information storage media having stored thereon instructions that, if executed, cause a transceiver to perform a method comprising: transmitting a message, wherein the message comprises one or more data variables that represent the test information,
5 wherein bits in the message are modulated onto DMT symbols using Quadrature Amplitude Modulation (QAM) with more than 1 bit per subchannel and wherein at least one data variable of the one or more data variables comprises an array representing Signal to Noise ratio per subchannel during Showtime information.

In accordance with another aspect of the present invention, there is provided a
10 non-transitory computer-readable information storage media having stored thereon instructions that, if executed, cause a transceiver to perform a method comprising: receiving a message, wherein the message comprises one or more data variables that represent the test information, wherein bits in the message were modulated onto DMT symbols using Quadrature Amplitude Modulation (QAM) with more than 1 bit per subchannel and wherein at least one data variable
15 of the one or more data variables comprises an array representing Signal to Noise ratio per subchannel during Showtime information.

In accordance with another aspect of the present invention, there is provided a method of communicating diagnostic information from a first transceiver to a second transceiver over a communication channel using multicarrier modulation comprising: transmitting an initiate
20 diagnostic mode message from the first transceiver to the second transceiver; and transmitting a diagnostic message using multicarrier modulation, wherein the diagnostic message comprises the diagnostic information about the communication channel and at least one bit in the diagnostic message is mapped to at least one REVERB signal.

In accordance with another aspect of the present invention, there is provided, in a
25 multicarrier modulation transceiver, a method of communicating diagnostic information over a communication channel using multicarrier modulation comprising: transmitting an initiate diagnostic mode message; and transmitting a diagnostic message using multicarrier modulation, wherein the diagnostic message comprises the diagnostic information about the communication channel and at least one bit in the diagnostic message is mapped to at least one
30 REVERB signal.

In accordance with another aspect of the present invention, there is provided, in a multicarrier modulation transceiver, a method of communicating diagnostic information over a communication channel using multicarrier modulation comprising: receiving an initiate

diagnostic mode message; and transmitting a diagnostic message using multicarrier modulation, wherein the diagnostic message comprises the diagnostic information about the communication channel and at least one bit in the diagnostic message is mapped to at least one REVERB signal.

5 In accordance with another aspect of the present invention, there is provided a method of communicating diagnostic information from a first transceiver to a second transceiver over a communication channel using multicarrier modulation comprising: transmitting an initiate diagnostic mode message from the first transceiver to the second transceiver; and transmitting a diagnostic message using a modulation scheme that comprises mapping at least one bit in the diagnostic message to at least one REVERB signal, wherein the diagnostic message comprises diagnostic information about the communication channel including at least one of a length of the diagnostic information, a time domain received reverb signal, a frequency domain reverb signal, an amplifier setting, a CO transmitter power spectral density, a frequency domain received idle channel, a signal to noise ratio, bits and gain information, and upstream and downstream transmission rates.

10 In accordance with another aspect of the present invention, there is provided, in a multicarrier communication transceiver, a method of communicating diagnostic information over a communication channel using multicarrier modulation comprising: transmitting an initiate diagnostic mode message; and transmitting a diagnostic message using a modulation scheme that comprises mapping at least one bit in the diagnostic message to at least one REVERB signal, wherein the diagnostic message comprises diagnostic information about the communication channel including at least one of a length of the diagnostic information, a time domain received reverb signal, a frequency domain reverb signal, an amplifier setting, a CO transmitter power spectral density, a frequency domain received idle channel, a signal to noise ratio, bits and gain information, and upstream and downstream transmission rates.

15 In accordance with another aspect of the present invention, there is provided, in a multicarrier communication transceiver, a method of communicating diagnostic information over a communication channel using multicarrier modulation comprising: receiving an initiate diagnostic mode message; and transmitting a diagnostic message using a modulation scheme that comprises mapping at least one bit in the diagnostic message to at least one REVERB signal, wherein the diagnostic message comprises diagnostic information about the communication channel including at least one of a length of the diagnostic information, a time domain received reverb signal, a frequency domain reverb signal, an amplifier setting, a CO

transmitter power spectral density, a frequency domain received idle channel, a signal to noise ratio, bits and gain information, and upstream and downstream transmission rates.

In accordance with another aspect of the present invention, there is provided a method of communicating diagnostic information from a first transceiver to a second transceiver over a communication channel using multicarrier modulation comprising: transmitting an initiate
5 diagnostic mode message from the first transceiver to the second transceiver; and transmitting a diagnostic message using a modulation scheme that comprises mapping at least one bit in the diagnostic message to at least one REVERB signal, wherein the diagnostic message comprises diagnostic information about the communication channel including at least one of a length of
10 the diagnostic information, a time domain received reverb signal, a frequency domain reverb signal, an amplifier setting, a CO transmitter power spectral density, a frequency domain received idle channel, a signal to noise ratio, bits and gain information, and upstream and downstream transmission rates and wherein the first transceiver transmits the initiate diagnostic mode message in the event steady state communications can not be established due to the
15 communication channel conditions.

In accordance with another aspect of the present invention, there is provided, in a multicarrier modulation transceiver, a method of communicating diagnostic information over a communication channel using multicarrier modulation comprising: transmitting an initiate
20 diagnostic mode message; and transmitting a diagnostic message using a modulation scheme that comprises mapping at least one bit in the diagnostic message to at least one REVERB signal, wherein the diagnostic message comprises diagnostic information about the communication channel including at least one of a length of the diagnostic information, a time domain received reverb signal, a frequency domain reverb signal, an amplifier setting, a CO transmitter power spectral density, a frequency domain received idle channel, a signal to noise
25 ratio, bits and gain information, and upstream and downstream transmission rates and wherein the first transceiver transmits the initiate diagnostic mode message in the event steady state communications can not be established due to the communication channel conditions.

In accordance with another aspect of the present invention, there is provided, in a multicarrier modulation transceiver, a method of communicating diagnostic information over a
30 communication channel using multicarrier modulation comprising: receiving an initiate diagnostic mode message; and transmitting a diagnostic message using a modulation scheme that comprises mapping at least one bit in the diagnostic message to at least one REVERB signal, wherein the diagnostic message comprises diagnostic information about the

communication channel including at least one of a length of the diagnostic information, a time domain received reverb signal, a frequency domain reverb signal, an amplifier setting, a CO transmitter power spectral density, a frequency domain received idle channel, a signal to noise ratio, bits and gain information, and upstream and downstream transmission rates and wherein
5 the first transceiver transmits the initiate diagnostic mode message in the event steady state communications can not be established due to the communication channel conditions.

In accordance with another aspect of the present invention, there is provided a diagnostic system that communicates diagnostic information over a communication channel using multicarrier modulation comprising: a first transceiver that transmits an initiate
10 diagnostic mode message to a second transceiver; and a message determination module that determines and, in cooperation with the first transceiver, transmits using multicarrier modulation a diagnostic message, wherein the diagnostic message comprises the diagnostic information about the communication channel and at least one bit in the diagnostic message is mapped to at least one REVERB signal.

15 In accordance with another aspect of the present invention, there is provided a diagnostic system that communicates diagnostic information over a communication channel using multicarrier modulation comprising: a transceiver that transmits an initiate diagnostic mode message; and a message determination module that determines and, in cooperation with the transceiver, transmits using multicarrier modulation a diagnostic message, wherein the
20 diagnostic message comprises the diagnostic information about the communication channel and at least one bit in the diagnostic message is mapped to at least one REVERB signal.

In accordance with another aspect of the present invention, there is provided a diagnostic system that communicates diagnostic information over a communication channel using multicarrier modulation comprising: a transceiver that receives an initiate diagnostic
25 mode message; and a message determination module that determines, and in cooperation with the transceiver, transmits using multicarrier modulation a diagnostic message, wherein the diagnostic message comprises the diagnostic information about the communication channel and at least one bit in the diagnostic message is mapped to at least one REVERB signal.

In accordance with another aspect of the present invention, there is provided a
30 diagnostic system that communicates diagnostic information over a communication channel using multicarrier modulation comprising: a first transceiver that completes a portion of initialization and transmits an initiate diagnostic mode message to a second transceiver; and a message determination module that determines and, in cooperation with the first transceiver,

transmits a diagnostic message using a modulation scheme that comprises mapping at least one bit in the diagnostic message to at least one REVERB signal, wherein the diagnostic message comprises diagnostic information about the communication channel including at least one of a length of the diagnostic information, a time domain received reverb signal, a frequency domain reverb signal, an amplifier setting, a CO transmitter power spectral density, a frequency domain received idle channel, a signal to noise ratio, bits and gain information, and upstream and downstream transmission rates.

In accordance with another aspect of the present invention, there is provided a diagnostic system that communicates diagnostic information over a communication channel using multicarrier modulation comprising: a transceiver that transmits an initiate diagnostic mode message; and a message determination module that determines, and in cooperation with the transceiver, transmits a diagnostic message using a modulation scheme that comprises mapping at least one bit in the diagnostic message to at least one REVERB signal, wherein the diagnostic message comprises diagnostic information about the communication channel including at least one of a length of the diagnostic information, a time domain received reverb signal, a frequency domain reverb signal, an amplifier setting, a CO transmitter power spectral density, a frequency domain received idle channel, a signal to noise ratio, bits and gain information, and upstream and downstream transmission rates.

In accordance with another aspect of the present invention, there is provided, in a multicarrier communication transceiver, a method of communicating diagnostic information over a communication channel using multicarrier modulation comprising: a transceiver that receives an initiate diagnostic mode message; and a message determination module that determines, and in cooperation with the transceiver, transmits a diagnostic message using a modulation scheme that comprises mapping at least one bit in the diagnostic message to at least one REVERB signal, wherein the diagnostic message comprises diagnostic information about the communication channel including at least one of a length of the diagnostic information, a time domain received reverb signal, a frequency domain reverb signal, an amplifier setting, a CO transmitter power spectral density, a frequency domain received idle channel, a signal to noise ratio, bits and gain information, and upstream and downstream transmission rates.

In accordance with another aspect of the present invention, there is provided a diagnostic system that communicates diagnostic information over a communication channel using multicarrier modulation comprising: a first transceiver that transmits an initiate diagnostic mode message to a second transceiver; and a message determination module that

determines and, in cooperation with the first transceiver, transmits a diagnostic message using a modulation scheme that comprises mapping at least one bit in the diagnostic message to at least one REVERB signal, wherein the diagnostic message comprises diagnostic information about the communication channel including at least one of a length of the diagnostic information, a time domain received reverb signal, a frequency domain reverb signal, an amplifier setting, a CO transmitter power spectral density, a frequency domain received idle channel, a signal to noise ratio, bits and gain information, and upstream and downstream transmission rates and wherein the first transceiver transmits the initiate diagnostic mode message in the event steady state communications can not be established due to the communication channel conditions.

10 In accordance with another aspect of the present invention, there is provided a diagnostic system that communicates diagnostic information over a communication channel using multicarrier modulation comprising: a transceiver that transmits an initiate diagnostic mode message; and a message determination module that determines and, in cooperation with the transceiver, transmits a diagnostic message using a modulation scheme that comprises
15 mapping at least one bit in the diagnostic message to at least one REVERB signal, wherein the diagnostic message comprises diagnostic information about the communication channel including at least one of a length of the diagnostic information, a time domain received reverb signal, a frequency domain reverb signal, an amplifier setting, a CO transmitter power spectral density, a frequency domain received idle channel, a signal to noise ratio, bits and gain
20 information, and upstream and downstream transmission rates and wherein the transceiver transmits the initiate diagnostic mode message in the event steady state communications can not be established due to the communication channel conditions.

In accordance with another aspect of the present invention, there is provided a diagnostic system that communicates diagnostic information over a communication channel
25 using multicarrier modulation comprising: a transceiver that receives an initiate diagnostic mode message; and a message determination module that determines and, in cooperation with the transceiver, transmits a diagnostic message using a modulation scheme that comprises mapping at least one bit in the diagnostic message to at least one REVERB signal, wherein the diagnostic message comprises diagnostic information about the communication channel
30 including at least one of a length of the diagnostic information, a time domain received reverb signal, a frequency domain reverb signal, an amplifier setting, a CO transmitter power spectral density, a frequency domain received idle channel, a signal to noise ratio, bits and gain information, and upstream and downstream transmission rates and wherein the transceiver

transmits the initiate diagnostic mode message in the event steady state communications can not be established due to the communication channel conditions.

In accordance with another aspect of the present invention, there is provided a system that communicates diagnostic channel information from a first transceiver to a second
5 transceiver over a communication channel using multicarrier modulation comprising: means for transmitting an initiate diagnostic mode message from the first transceiver to the second transceiver; and means for transmitting a diagnostic message using a modulation scheme that comprises mapping at least one bit in the diagnostic message to at least one REVERB signal, wherein the diagnostic message comprises diagnostic information about the communication
10 channel including at least one of a length of the diagnostic information, a time domain received reverb signal, a frequency domain reverb signal, an amplifier setting, a CO transmitter power spectral density, a frequency domain received idle channel, a signal to noise ratio, bits and gain information, and upstream and downstream transmission rates.

In accordance with another aspect of the present invention, there is provided, in a
15 multicarrier communication transceiver, a system that communicates diagnostic information over a communication channel using multicarrier modulation comprising: transmitting an initiate diagnostic mode message; and transmitting a diagnostic message using a modulation scheme that comprises mapping at least one bit in the diagnostic message to at least one REVERB signal, wherein the diagnostic message comprises diagnostic information about the
20 communication channel including at least one of a length of the diagnostic information, a time domain received reverb signal, a frequency domain reverb signal, an amplifier setting, a CO transmitter power spectral density, a frequency domain received idle channel, a signal to noise ratio, bits and gain information, and upstream and downstream transmission rates.

In accordance with another aspect of the present invention, there is provided, in a
25 multicarrier communication transceiver, a system that communicates diagnostic information over a communication channel using multicarrier modulation comprising: means for receiving an initiate diagnostic mode message; and means for transmitting a diagnostic message using a modulation scheme that comprises mapping at least one bit in the diagnostic message to at least one REVERB signal, wherein the diagnostic message comprises diagnostic information about
30 the communication channel including at least one of a length of the diagnostic information, a time domain received reverb signal, a frequency domain reverb signal, an amplifier setting, a CO transmitter power spectral density, a frequency domain received idle channel, a signal to noise ratio, bits and gain information, and upstream and downstream transmission rates.

In accordance with another aspect of the present invention, there is provided a system that communicates diagnostic information from a first transceiver to a second transceiver over a communication channel using multicarrier modulation comprising: means for transmitting an initiate diagnostic mode message from the first transceiver to the second transceiver; and means
5 for transmitting a diagnostic message using a modulation scheme that comprises mapping at least one bit in the diagnostic message to at least one REVERB signal, wherein the diagnostic message comprises diagnostic information about the communication channel including at least one of a length of the diagnostic information, a time domain received reverb signal, a frequency domain reverb signal, an amplifier setting, a CO transmitter power spectral density, a frequency
10 domain received idle channel, a signal to noise ratio, bits and gain information, and upstream and downstream transmission rates and wherein the first transceiver transmits the initiate diagnostic mode message in the event steady state communications can not be established due to the communication channel conditions.

In accordance with another aspect of the present invention, there is provided, in a
15 multicarrier modulation transceiver, a system that communicates diagnostic information over a communication channel using multicarrier modulation comprising: means for transmitting an initiate diagnostic mode message; and means for transmitting a diagnostic message using a modulation scheme that comprises mapping at least one bit in the diagnostic message to at least one REVERB signal, wherein the diagnostic message comprises diagnostic information about
20 the communication channel including at least one of a length of the diagnostic information, a time domain received reverb signal, a frequency domain reverb signal, an amplifier setting, a CO transmitter power spectral density, a frequency domain received idle channel, a signal to noise ratio, bits and gain information, and upstream and downstream transmission rates and wherein the first transceiver transmits the initiate diagnostic mode message in the event steady
25 state communications can not be established due to the communication channel conditions.

In accordance with another aspect of the present invention, there is provided in a multicarrier modulation transceiver, a system for communicating diagnostic information over a communication channel using multicarrier modulation comprising: means for receiving an initiate diagnostic mode message; and means for transmitting a diagnostic message using a
30 modulation scheme that comprises mapping at least one bit in the diagnostic message to at least one REVERB signal, wherein the diagnostic message comprises diagnostic information about the communication channel including at least one of a length of the diagnostic information, a time domain received reverb signal, a frequency domain reverb signal, an amplifier setting, a

CO transmitter power spectral density, a frequency domain received idle channel, a signal to noise ratio, bits and gain information, and upstream and downstream transmission rates and wherein the first transceiver transmits the initiate diagnostic mode message in the event steady state communications can not be established due to the communication channel conditions.

5 In accordance with another aspect of the present invention, there is provided a protocol for communicating diagnostic information from a first transceiver to a second transceiver over a communication channel using multicarrier modulation comprising: transmitting an initiate diagnostic mode message from the first transceiver to the second transceiver; and transmitting a diagnostic message using a modulation scheme that comprises mapping at least one bit in the
10 diagnostic message to at least one REVERB signal, wherein the diagnostic message comprises diagnostic information about the communication channel including at least one of a length of the diagnostic information, a time domain received reverb signal, a frequency domain reverb signal, an amplifier setting, a CO transmitter power spectral density, a frequency domain received idle channel, a signal to noise ratio, bits and gain information, and upstream and
15 downstream transmission rates.

In accordance with another aspect of the present invention, there is provided, in a multicarrier communication transceiver, a protocol for communicating diagnostic information over a communication channel using multicarrier modulation comprising: transmitting an initiate diagnostic mode message; and transmitting a diagnostic message using a modulation
20 scheme that comprises mapping at least one bit in the diagnostic message to at least one REVERB signal, wherein the diagnostic message comprises diagnostic information about the communication channel including at least one of a length of the diagnostic information, a time domain received reverb signal, a frequency domain reverb signal, an amplifier setting, a CO transmitter power spectral density, a frequency domain received idle channel, a signal to noise
25 ratio, bits and gain information, and upstream and downstream transmission rates.

In accordance with another aspect of the present invention, there is provided, in a multicarrier communication transceiver, a protocol for communicating diagnostic information over a communication channel using multicarrier modulation comprising: receiving an initiate diagnostic mode message; and transmitting a diagnostic message using a modulation scheme
30 that comprises mapping at least one bit in the diagnostic message to at least one REVERB signal, wherein the diagnostic message comprises diagnostic information about the communication channel including at least one of a length of the diagnostic information, a time domain received reverb signal, a frequency domain reverb signal, an amplifier setting, a CO

transmitter power spectral density, a frequency domain received idle channel, a signal to noise ratio, bits and gain information, and upstream and downstream transmission rates.

In accordance with another aspect of the present invention, there is provided a protocol for communicating diagnostic information from a first transceiver to a second transceiver over a communication channel using multicarrier modulation comprising: transmitting an initiate diagnostic mode message from the first transceiver to the second transceiver; and transmitting a diagnostic message using a modulation scheme that comprises mapping at least one bit in the diagnostic message to at least one REVERB signal, wherein the diagnostic message comprises diagnostic information about the communication channel including at least one of a length of the diagnostic information, a time domain received reverb signal, a frequency domain reverb signal, an amplifier setting, a CO transmitter power spectral density, a frequency domain received idle channel, a signal to noise ratio, bits and gain information, and upstream and downstream transmission rates and wherein the first transceiver transmits the initiate diagnostic mode message in the event steady state communications can not be established due to the communication channel conditions.

In accordance with another aspect of the present invention, there is provided, in a multicarrier modulation transceiver, a protocol for communicating diagnostic information over a communication channel using multicarrier modulation comprising: transmitting an initiate diagnostic mode message; and transmitting a diagnostic message using a modulation scheme that comprises mapping at least one bit in the diagnostic message to at least one REVERB signal, wherein the diagnostic message comprises diagnostic information about the communication channel including at least one of a length of the diagnostic information, a time domain received reverb signal, a frequency domain reverb signal, an amplifier setting, a CO transmitter power spectral density, a frequency domain received idle channel, a signal to noise ratio, bits and gain information, and upstream and downstream transmission rates and wherein the first transceiver transmits the initiate diagnostic mode message in the event steady state communications can not be established due to the communication channel conditions.

In accordance with another aspect of the present invention, there is provided, in a multicarrier modulation transceiver, a protocol for communicating diagnostic information over a communication channel using multicarrier modulation comprising: receiving an initiate diagnostic mode message; and transmitting a diagnostic message using a modulation scheme that comprises mapping at least one bit in the diagnostic message to at least one REVERB signal, wherein the diagnostic message comprises diagnostic information about the

communication channel including at least one of a length of the diagnostic information, a time domain received reverb signal, a frequency domain reverb signal, an amplifier setting, a CO transmitter power spectral density, a frequency domain received idle channel, a signal to noise ratio, bits and gain information, and upstream and downstream transmission rates and wherein the first transceiver transmits the initiate diagnostic mode message in the event steady state communications can not be established due to the communication channel conditions.

In accordance with another aspect of the present invention, there is provided an information storage media comprising information that communicates diagnostic information from a first transceiver to a second transceiver over a communication channel using multicarrier modulation comprising: information that transmits an initiate diagnostic mode message from the first transceiver to the second transceiver; and information that transmits a diagnostic message using a modulation scheme that comprises mapping at least one bit in the diagnostic message to at least one REVERB signal, wherein the diagnostic message comprises diagnostic information about the communication channel including at least one of a length of the diagnostic information, a time domain received reverb signal, a frequency domain reverb signal, an amplifier setting, a CO transmitter power spectral density, a frequency domain received idle channel, a signal to noise ratio, bits and gain information, and upstream and downstream transmission rates.

In accordance with another aspect of the present invention, there is provided an information storage media comprising information that communicates diagnostic information over a communication channel using multicarrier modulation comprising: information that transmits an initiate diagnostic mode message; and information that transmits a diagnostic message using a modulation scheme that comprises mapping at least one bit in the diagnostic message to at least one REVERB signal, wherein the diagnostic message comprises diagnostic information about the communication channel including at least one of a length of the diagnostic information, a time domain received reverb signal, a frequency domain reverb signal, an amplifier setting, a CO transmitter power spectral density, a frequency domain received idle channel, a signal to noise ratio, bits and gain information, and upstream and downstream transmission rates.

In accordance with another aspect of the present invention, there is provided an information storage media comprising information that communicates diagnostic information over a communication channel using multicarrier modulation comprising: information that receives an initiate diagnostic mode message; and information that transmits a diagnostic

message using a modulation scheme that comprises mapping at least one bit in the diagnostic message to at least one REVERB signal, wherein the diagnostic message comprises diagnostic information about the communication channel including at least one of a length of the diagnostic information, a time domain received reverb signal, a frequency domain reverb signal, an amplifier setting, a CO transmitter power spectral density, a frequency domain received idle channel, a signal to noise ratio, bits and gain information, and upstream and downstream transmission rates.

In accordance with another aspect of the present invention, there is provided an information storage media comprising information that communicates diagnostic information from a first transceiver to a second transceiver over a communication channel using multicarrier modulation comprising: information that transmits an initiate diagnostic mode message from the first transceiver to the second transceiver; and information that transmits a diagnostic message using a modulation scheme that comprises mapping at least one bit in the diagnostic message to at least one REVERB signal, wherein the diagnostic message comprises diagnostic information about the communication channel including at least one of a length of the diagnostic information, a time domain received reverb signal, a frequency domain reverb signal, an amplifier setting, a CO transmitter power spectral density, a frequency domain received idle channel, a signal to noise ratio, bits and gain information, and upstream and downstream transmission rates and wherein the first transceiver transmits the initiate diagnostic mode message in the event steady state communications can not be established due to the communication channel conditions.

In accordance with another aspect of the present invention, there is provided an information storage media comprising information that communicates diagnostic information over a communication channel using multicarrier modulation comprising: information that transmits an initiate diagnostic mode message; and information that transmits a diagnostic message using a modulation scheme that comprises mapping at least one bit in the diagnostic message to at least one REVERB signal, wherein the diagnostic message comprises diagnostic information about the communication channel including at least one of a length of the diagnostic information, a time domain received reverb signal, a frequency domain reverb signal, an amplifier setting, a CO transmitter power spectral density, a frequency domain received idle channel, a signal to noise ratio, bits and gain information, and upstream and downstream transmission rates and wherein the first transceiver transmits the initiate diagnostic

mode message in the event steady state communications can not be established due to the communication channel conditions.

In accordance with another aspect of the present invention, there is provided an information storage media comprising information that communicates diagnostic information
5 over a communication channel using multicarrier modulation comprising: information that receives an initiate diagnostic mode message; and information that transmits a diagnostic message using a modulation scheme that comprises mapping at least one bit in the diagnostic message to at least one REVERB signal, wherein the diagnostic message comprises diagnostic information about the communication channel including at least one of a length of the diagnostic
10 information, a time domain received reverb signal, a frequency domain reverb signal, an amplifier setting, a CO transmitter power spectral density, a frequency domain received idle channel, a signal to noise ratio, bits and gain information, and upstream and downstream transmission rates and wherein the first transceiver transmits the initiate diagnostic mode message in the event steady state communications can not be established due to the
15 communication channel conditions.

In an aspect, there is provided a multicarrier transceiver comprising: a transmitter operable to transmit or a receiver operable to receive a first message comprising an array comprising a plurality of elements, wherein each element comprises information associated with a signal to noise ratio during training of at least one subchannel, the transmitter further operable
20 to transmit or the receiver further operable to receive a second message comprising an array comprising a plurality of elements, wherein each element comprises information associated with a signal to noise ratio during a normal steady state transmission mode of at least one subchannel. The first message may be transmitted or received during a diagnostic mode and the second message may be transmitted or received during the normal steady state transmission mode. The
25 transmitter may be further operable to transmit an initiate diagnostic mode message or the receiver may be further operable to receive an initiate diagnostic mode message. The receiver may be further operable to measure the signal to noise ratio during training and may be operable to measure the signal to noise ratio during the normal steady state transmission mode. The receiver may be operable to determine whether a predetermined error threshold has been
30 exceeded during the normal steady state transmission mode, wherein the predetermined error threshold may be based on cyclic redundancy check (CRC) errors during the normal steady state

transmission mode. The first message may also comprise a second array which represents power level per subchannel information and a third parameter which represents power spectral density information. The receiver may be further operable to receive the first message a plurality of times, and wherein the probability of correctly receiving the first message may be improved by using diversity combining of the received messages. The initiate diagnostic mode message may be transmitted at the direction of a technician. The transceiver may be a digital subscriber line (DSL) central office transceiver. The transceiver may be a DSL remote terminal transceiver.

In another aspect, there is provided a diagnostic link system for communicating data between modems using multicarrier modulation comprising: an initiate diagnostic mode trigger that instructs a transmitting modem to forward an initiate diagnostic mode message to a receiving modem; a message determination device that determines a diagnostic link message; and a receiving modem diagnostic device that receives the diagnostic link message and determines the accuracy of the diagnostic link message.

In another aspect, there is provided a method for communicating data between modems using multicarrier modulation comprising: determining a diagnostic link message; transmitting the diagnostic link message; and at least one of increasing a transmission power of the diagnostic link message if the received diagnostic link message is inaccurate and re-transmitting the diagnostic link message a predetermined number of times.

Exemplary embodiments of this invention are directed toward reliably exchanging diagnostic and test information between transceivers over a digital subscriber line in the presence of voice communications and/or other disturbances. For simplicity of reference, the

systems and methods of the invention will hereafter refer to the transceivers generically as modems. One such modem is typically located at a customer premises such as a home or business and is "downstream" from a central office with which it communicates. The other modem is typically located at the central office and is "upstream" from the customer premises. Consistent with industry practice, the modems are often referred to as "ATU-R" ("ADSL transceiver unit, remote," i.e., located at the customer premises) and "ATU-C" ("ADSL transceiver unit, central office" i.e., located at the central office). Each modem includes a transmitter section for transmitting data and a receiver section for receiving data, and is of the discrete multitone type, i.e., the modem transmits data over a multiplicity of subchannels of limited bandwidth. Typically, the upstream or ATU-C modem transmits data to the downstream or ATU-R modem over a first set of subchannels, which are usually the higher-frequency subchannels, and receives data from the downstream or ATU-R modem over a second, usually smaller, set of subchannels, commonly the lower-frequency subchannels. By establishing a diagnostic link mode between the two modems, the systems and methods of this invention are able to exchange diagnostic and test information in a simple and robust manner.

In the diagnostic link mode, the diagnostic and test information is communicated using a signaling mechanism that has a very high immunity to noise and/or other disturbances and can therefore operate effectively even in the case where the modems could not actually establish an acceptable connection in their normal operational mode.

For example, if the ATU-C and/or ATU-R modem fail to complete an initialization sequence, and are thus unable to enter a normal steady state communications mode, where the diagnostic and test information would normally be exchanged, the modems according to the systems and methods of this invention enter a robust diagnostic link mode. Alternatively, the diagnostic link mode can be entered automatically or manually, for example, at the direction of a user. In the robust diagnostic link mode, the modems exchange the diagnostic and test information that is, for example, used by a technician to determine the cause of a failure without the technician having to physically visit, i.e., a truckroll to, the remote site to collect data.

The diagnostic and test information can include, for example, but is not limited to, signal to noise ratio information, equalizer information, programmable gain setting information, bit allocation information, transmitted and received power information, margin information, status and rate information, telephone line condition information, such as the length of the line, the number and location of bridged taps, a wire gauge, or the like, or any

other known or later developed diagnostic or test information that may be appropriate for the particular communications environment. For example, the exchanged diagnostic and test information can be directed toward specific limitations of the modems, to information relating to the modem installation and deployment environment, or to other diagnostic and test information that can, for example, be determined as needed which may aid in evaluating the cause of a specific failure or problem. Alternatively, the diagnostic and test information can include the loop length and bridged tap length estimations as discussed in US 6,865,221.

For example, an exemplary embodiment of the invention illustrates the use of the diagnostic link mode in the communication of diagnostic information from the remote terminal (RT) transceiver, e.g., ATU-R, to the central office (CO) transceiver, e.g., ATU-C. Transmission of information from the remote terminal to the central office is important since a typical ADSL service provider is located in the central office and would therefore benefit from the ability to determine problems at the remote terminal without a truckroll. However, it is to be appreciated, that the systems and the methods of this invention will work equally well in communications from the central office to the remote terminal.

These and other features and advantages of this invention are described in or are apparent from the following detailed description of the embodiments.

BRIEF DESCRIPTION OF THE DRAWINGS

The embodiments of the invention will be described in detail, with reference to the following figures wherein:

Fig. 1 is a functional block diagram illustrating an exemplary communications system according to this invention; and

Fig. 2 is a flowchart outlining an exemplary method for communicating diagnostic and test information according to this invention.

DETAILED DESCRIPTION OF THE INVENTION

For ease of illustration the following description will be described in relation to the CO receiving diagnostic and test information from the RT. In the exemplary embodiment, the systems and methods of this invention complete a portion of the normal modem initialization before entering into the diagnostic link mode. The systems and methods of this invention can enter the diagnostic link mode manually, for example, at the direction of a

technician or a user after completing a portion of initialization. Alternatively, the systems and methods of this invention can enter the diagnostic link mode automatically based on, for example, a bit rate failure, a forward error correction or a CRC error during showtime, e.g., the normal steady state transmission mode, or the like. The transition into the diagnostic link mode is accomplished by transmitting a message from the CO modem to the RT modem indicating that the modems are to enter into the diagnostic link mode, as opposed to transitioning into the normal steady state data transmission mode. Alternatively, the transition into the diagnostic link mode is accomplished by transmitting a message from the RT modem to the CO modem indicating that the modems are to enter into the diagnostic link mode as opposed to transitioning into the normal steady state data transmission mode. For example, the transition signal uses an ADSL state transition to transition from a standard ADSL state to a diagnostic link mode state.

In the diagnostic link mode, the RT modem sends diagnostic and test information in the form of a collection of information bits to the CO modem that are, for example, modulated by using one bit per DTM symbol modulation, as is used in the C-Rates1 message in the ITU and ANSI ADSL standards, where the symbol may or may not include a cyclic prefix. Other exemplary modulation techniques include Differential Phase Shift Keying (DPSK) on a subset or all the carriers, as specified in, for example, ITU standard G.994.1, higher order QAM modulation (>1 bit per carrier), or the like.

In the one bit per DMT symbol modulation message encoding scheme, a bit with value 0 is mapped to the REVERB1 signal and a bit with a value of 1 mapped to a SEGUE1 signal. The REVERB1 and SEGUE1 signals are defined in the ITU and ANSI ADSL standards. The REVERB1 signal is generated by modulating all of the carriers in the multicarrier system with a known pseudo-random sequence thus generating a wideband modulated signal. The SEGUE1 signal is generated from a carrier by 180 degree phase reversal of the REVERB1 signal. Since both signals are wideband and known in advance, the receiver can easily detect the REVERB1 and SEGUE1 signal using a simple matched filter in the presence of large amounts of noise and other disturbances.

Exemplary Message Variables
Data Sent in the Diag Link
Train Type
ADSL Standard
Chip Type
Vendor ID
Code Version
Average Reverb Received Signal
Programmable gain amplifier (PGA) Gain – Training
Programmable gain amplifier PGA Gain – Showtime
Filter Present during Idle Channel Calculation
Average Idle Channel Noise
Signal to Noise during Training
Signal to Noise during Showtime
Bits and Gains
Data Rate
Framing Mode
Margin
Reed-Solomon Coding Gain
QAM Usage
Frequency Domain Equalizer (FDQ) Coefficients
Gain Scale
Time domain equalizer (TDQ) Coefficients
Digital Echo Canceller (DEC) Coefficients

5

Table 1

Table 1 shows an example of a data message that can be sent by the RT to the CO during the diagnostic link mode. In this example, the RT modem sends 23 different data variables to the CO. Each data variable contains different items of diagnostic and test information that are used to analyze the condition of the link. The variables may contain more than one item of data. For example, the *Average Reverb Signal* contains the power levels per tone, up to, for example, 256 entries, detected during the ADSL Reverb signal. Conversely, the *PGA Gain – Training* is a single entry, denoting the gain in dB at the receiver during the ADSL training.

Many variables that represent the type of diagnostic and test information that are used to analyze the condition of the link are sent from the RT modem to the CO modem. These variables can be, for example, arrays with different lengths depending on, for example, information in the initiate diagnostic mode message. The systems and methods of this invention can be tailored to contain many different diagnostic and test information variables.

15

Thus, the system is fully configurable, allowing subsets of data to be sent and additional data variables to be added in the future. Therefore, the message length can be increased or decreased, and diagnostic and test information customized, to support more or less variables as, for example, hardware, the environment and/or the telecommunications equipment dictates.

Therefore, it is to be appreciated, that in general the variables transmitted from the modem being tested to the receiving modem can be any combination of variables which allow for transmission of test and/or diagnostic information.

Fig. 1 illustrates an exemplary embodiment of the additional modem components associated with the diagnostic link mode. In particular, the diagnostic link system 100 comprises a central office modem 200 and a remote terminal modem 300. The central office modem 200 comprises, in addition to the standard ATU-C components, a CRC checker 210, a diagnostic device 220, and a diagnostic information monitoring device 230. The remote terminal modem 300 comprises, in addition to the standard components associated with an ATU-R, a message determination device 310, a power control device 320, a diagnostic device 330 and a diagnostic information storage device 340. The central office modem 200 and the remote terminal model 300 are also connected, via link 5, to a splitter 10 for a phone switch 20, and a splitter 30 for a phone 40. Alternatively, the ATU-R can operate without a splitter, e.g., splitterless, as specified in ITU standard G.992.2 (G.lite) or with an in-line filter in series with the phone 40. In addition, the remote terminal modem 300, can also be connected to, for example, one or more user terminals 60. Additionally, the central office modem 200 can be connected to one or more distributed networks 50, via link 5, which may or may not also be connected to one or more other distributed networks.

While the exemplary embodiment illustrated in Fig. 1 shows the diagnostic link system 100 for an embodiment in which the remote terminal modem 300 is communicating test and diagnostic information to the central office 200, it is to be appreciated that the various components of the diagnostic link system can be rearranged such that the diagnostic and test information can be forwarded from the central office 200 to the remote terminal modem 300, or, alternatively, such that both modems can send and receive diagnostic and/or test information. Furthermore, it is to be appreciated, that the components of the diagnostic link system 100 can be located at various locations within a distributed network, such as the POTS network, or other comparable telecommunications network. Thus, it should be appreciated that the components of the diagnostic link system 100 can be combined into one device for respectively transmitting, receiving, or transmitting and receiving diagnostic

and/or test information. As will be appreciated from the following description, and for reasons of computational efficiency, the components of the diagnostic link system 100 can be arranged at any location within a telecommunications network and/or modem without affecting the operation of the system.

5 The links 5 can be a wired or wireless link or any other known or later developed element(s) that is capable of supplying and communicating electronic data to and from the connected elements. Additionally, the user terminal 60 can be, for example, a personal computer or other device allowing a user to interface with and communicate over a modem, such as a DSL modem. Furthermore, the systems and method of this invention will work
10 equally well with splitterless and low-pass multicarrier modem technologies.

 In operation, the remote terminal 300, commences its normal initialization sequence. The diagnostic device 330 monitors the initialization sequence for a failure. If there is a failure, the diagnostic device 330 initiates the diagnostic link mode. Alternatively, a user or, for example, a technician at the CO, can specify that the remote terminal 300 enter into the
15 diagnostic link mode after completing a portion of an initialization. Alternatively still, the diagnostic device 330 can monitor the normal steady state data transmission of the remote terminal, and upon, for example, an error threshold being exceeded, the diagnostic device 330 will initiate the diagnostic link mode.

 Upon initialization of the diagnostic link mode, the diagnostic device 330, in
20 cooperation with the remote terminal 300 will transmit an initiate diagnostic link mode message from the remote terminal to the central office 200 (RT to CO). Alternatively, the central office modem 200 can transmit an initiate diagnostic link mode message to the remote terminal modem 300. If the initiate diagnostic link mode message is received by the central office 200, the diagnostic device 330, in cooperation with the message determination device
25 310, determines a diagnostic link message to be forwarded to the central office 200. For example, the diagnostic link message can include test information that has been assembled during, for example, the normal ADSL initialization procedure. The diagnostic and/or test information can include, but is not limited to, the version number of the diagnostic link mode, the length of the diagnostic and/or test information, the communications standard, such as the
30 ADSL standard, the chipset type, the vendor identifications, the ATU version number, the time domain received reverb signal, the frequency domain reverb signal, the amplifier settings, the CO transmitter power spectral density, the frequency domain received idle channel, the signal to noise ratio, the bits and gains and the upstream and downstream transmission rates, or the like.

If the initiate diagnostic link mode message is not received by the central office 200, the initiate diagnostic link mode message can, for example, be re-transmitted a predetermined number of iterations until a determination is made that it is not possible to establish a connection.

5 Assuming the initiate diagnostic link mode message is received, then, for a predetermined number of iterations, the diagnostic device 330, in cooperation with the remote terminal modem 300 and the diagnostic information storage device 340, transmits the diagnostic link message with a cyclic redundancy check (CRC) to the central office modem 200. However, it is to be appreciated that in general, any error detection scheme, such as bit
10 error detection, can be used without affecting the operation of the system. The central office 200, in cooperation with the CRC checker 210, determines if the CRC is correct. If the CRC is correct, the diagnostic information stored in the diagnostic information storage device 340 has been, with the cooperation of the diagnostic device 330, and the remote terminal modem 300, forwarded to the central office 200 successfully.

15 If, for example, the CRC checker 210 is unable to determine the correct CRC, the diagnostic device 330, in cooperation with power control device 320, increases the transmission power of the remote terminal 300 and repeats the transmission of the diagnostic link message from the remote terminal 300 to the central office 200. This process continues until the correct CRC is determined by the CRC checker 210.

20 The maximum power level used for transmission of the diagnostic link message can be specified by, for example, the user or the ADSL service operator. If the CRC checker 210 does not determine a correct CRC at the maximum power level and the diagnostic link mode can not be initiated then other methods for determining diagnostic information are utilized, such as dispatching a technician to the remote site, or the like.

25 Alternatively, the remote terminal 300, with or without an increase in the power level, can transmit the diagnostic link message several times, for example, 4 times. By transmitting the diagnostic link message several times, the CO modem 200 can use, for example, a diversity combining scheme to improve the probability of obtaining a correct CRC from the received diagnostic link message(s).

30 Alternatively, as previously discussed, the central office 200 comprises a diagnostic information monitoring device 230. The remote terminal 300 can also include a diagnostic information monitoring device. One or more of these diagnostic information monitoring devices can monitor the normal steady state data transmission between the remote terminal 300 and the central office 200. Upon, for example, the normal steady state data transmission

exceeded a predetermined error threshold, the diagnostic information monitoring device can initiate the diagnostic link mode with the cooperation of the diagnostic device 300 and/or the diagnostic device 220.

Fig. 2 illustrates an exemplary method for entering a diagnostic link mode in accordance with this invention. In particular, control begins in step S100 and continues to step S110. In step S110, the initialization sequence is commenced. Next, in step S120, if an initialization failure is detected, control continues to step S170. Otherwise, control jumps to step S130. In step S130, a determination is made whether the diagnostic link mode has been selected. If the diagnostic link mode has been selected, control continues to step S170, otherwise, control jumps to step S140:

In step S170, the initiate diagnostic link mode message is transmitted from, for example, the remote terminal to the central office. Next, in step S180, a determination is made whether the initiate diagnostic mode message has been received by the CO. If the initiate diagnostic mode message has been received by the CO, control jumps to step S200. Otherwise, control continues to step S190. In step S190, a determination is made whether to re-transmit the initiate diagnostic mode message, for example, based on whether a predetermined number of iterations have already been completed. If the initiate diagnostic mode message is to be re-transmitted, control continues back to step S170. Otherwise, control jumps to step S160.

In step S200, the diagnostic link message is determined, for example, by assembling test and diagnostic information about one or more of the local loop, the modem itself, the telephone network at the remote terminal, or the like. Next, in step S210, for a predetermined number of iterations, steps S220-S240 are completed. In particular, in step S220 a diagnostic link message comprising a CRC is transmitted to, for example, the CO. Next, in step S230, the CRC is determined. Then, in step S240, a determination is made whether the CRC is correct. If the CRC is correct, the test and/or diagnostic information has been successfully communicated and control continues to step S160.

Otherwise, if step S210 has completed the predetermined number of iterations, control continues to step S250. In step S250, the transmission power is increased and control continues back to step S210. Alternatively, as previously discussed, the diagnostic link message may be transmitted a predetermined number of times, with or without a change in the transmission power.

In step S140, the normal steady state data transmission is entered into between two modems, such as the remote terminal and the central office modems. Next, in step S150, a

determination is made whether an error threshold during the normal steady state data transmission has been exceeded. If the error threshold has been exceeded, control continues to step S170. Otherwise, control jumps to step S160. In step S160, the control sequence ends.

5 As shown in Fig. 1, the diagnostic link mode system can be implemented either on a single program general purpose computer, a modem, such as a DSL modem, or a separate program general purpose computer having a communications device. However, the diagnostic link system can also be implemented on a special purpose computer, a
10 programmed microprocessor or microcontroller and peripheral integrated circuit element, an ASIC or other integrated circuit, a digital signal processor, a hardwired electronic or logic circuit such as a discrete element circuit, a programmed logic device such as a PLD, PLA, FPGA, PAL, or the like, and associated communications equipment. In general, any device capable of implementing a finite state machine that is capable of implementing the flowchart illustrated in Fig. 2 can be used to implement a diagnostic link system according to this
15 invention:

 Furthermore, the disclosed method may be readily implemented in software using object or object-oriented software development environments that provide portable source code that can be used on a variety of computer, workstation, or modem hardware platforms. Alternatively, the disclosed diagnostic link system may be implemented partially or fully in
20 hardware using standard logic circuits or a VLSI design. Other software or hardware can be used to implement the systems in accordance with this invention depending on the speed and/or efficiency requirements of the systems, the particular function, and a particular software or hardware systems or microprocessor or microcomputer systems being utilized. The diagnostic link system and methods illustrated herein however, can be readily
25 implemented in hardware and/or software using any known or later developed systems or structures, devices and/or software by those of ordinary skill in the applicable art from the functional description provided herein and with a general basic knowledge of the computer and telecommunications arts.

 Moreover, the disclosed methods can be readily implemented as software executed on
30 a programmed general purpose computer, a special purpose computer, a microprocessor, or the like. In these instances, the methods and systems of this invention can be implemented as a program embedded on a modem, such a DSL modem, as a resource residing on a personal computer, as a routine embedded in a dedicated diagnostic link system, a central office, or the like. The diagnostic link system can also be implemented by physically incorporating the

system and method into a software and/or hardware system, such as a hardware and software systems of a modem, a general purpose computer, an ADSL line testing device, or the like.

It is, therefore, apparent that there is provided in accordance with the present invention, systems and methods for transmitting a diagnostic link message. While this invention has been
5 described in conjunction with a number of embodiments, it is evident that many alternatives, modifications and variations would be or are apparent to those of ordinary skill in the applicable arts. Accordingly, applicants intend to embrace all such alternatives, modifications, equivalents and variations that are within the scope of this invention as defined by the claims.

What is claimed is:

1. A multicarrier transceiver comprising:
a transmitter operable to transmit or a receiver operable to receive a first message comprising an array comprising a plurality of elements, wherein each element comprises information associated with a signal to noise ratio during training of at least one subchannel,
the transmitter further operable to transmit or the receiver further operable to receive a second message comprising an array comprising a plurality of elements, wherein each element comprises information associated with a signal to noise ratio during a normal steady state transmission mode of at least one subchannel.
2. The multicarrier transceiver of claim 1, wherein the first message is transmitted or received during a diagnostic mode and the second message is transmitted or received during the normal steady state transmission mode.
3. The multicarrier transceiver of claim 1, wherein the transmitter is further operable to transmit an initiate diagnostic mode message or the receiver is further operable to receive an initiate diagnostic mode message.
4. The multicarrier transceiver of claim 1, wherein the receiver is further operable to measure the signal to noise ratio during training and operable to measure the signal to noise ratio during the normal steady state transmission mode.
5. The multicarrier transceiver of claim 1, wherein the receiver is operable to determine whether a predetermined error threshold has been exceeded during the normal steady state transmission mode, wherein the predetermined error threshold is based on cyclic redundancy check (CRC) errors during the normal steady state transmission mode.

6. The multicarrier transceiver of claim 1, wherein the first message also comprises a second array which represents power level per subchannel information and a third parameter which represents power spectral density information.

7. The multicarrier transceiver of claim 1, wherein the receiver is further operable to receive the first message a plurality of times, and wherein the probability of correctly receiving the first message is improved by using diversity combining of the received messages.

8. The multicarrier transceiver of claim 3, wherein the initiate diagnostic mode message is transmitted at the direction of a technician.

9. The multicarrier transceiver of claim 1, wherein the transceiver is a digital subscriber line (DSL) central office transceiver.

10. The multicarrier transceiver of claim 1, wherein the transceiver is a digital subscriber line (DSL) remote terminal transceiver.

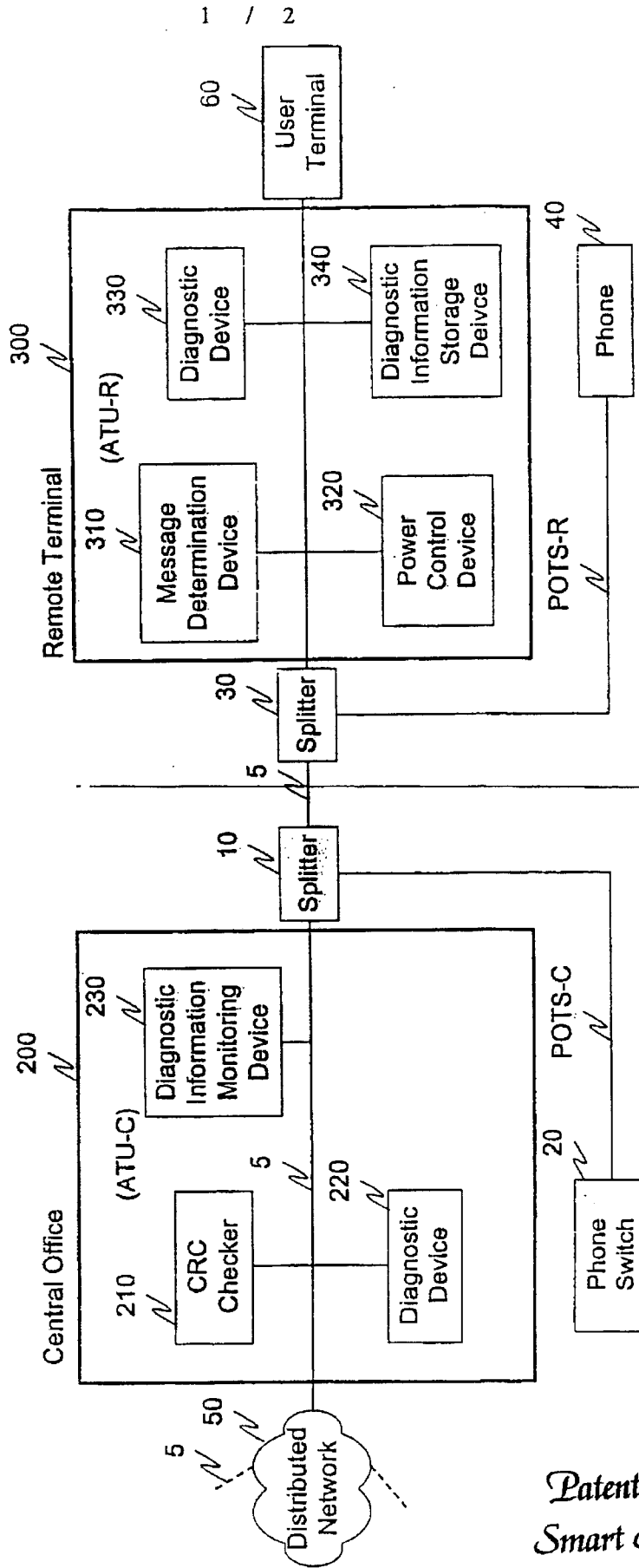

Fig. 1

Patent Agents
Smart & Biggar

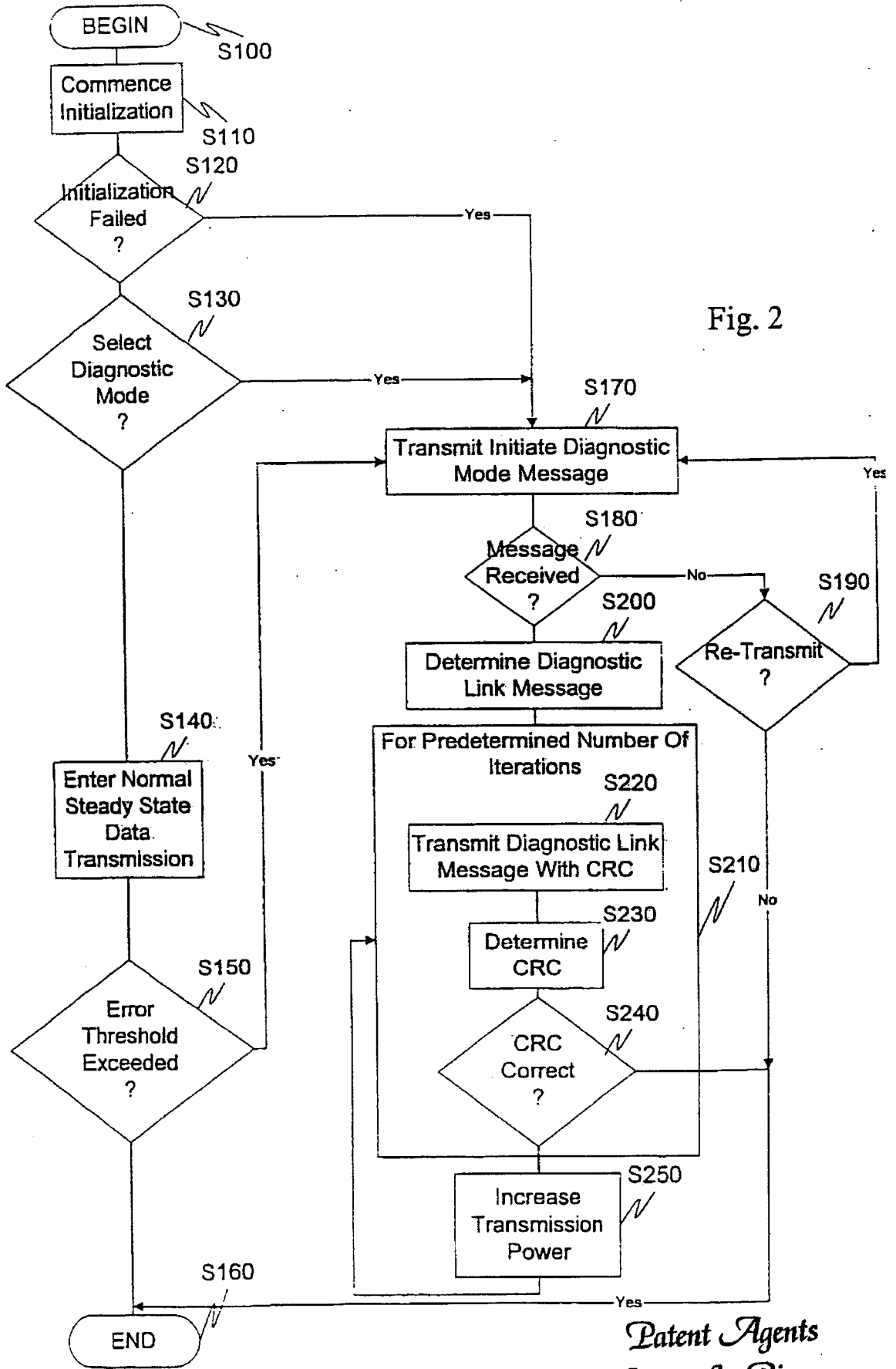

Fig. 2

