

**(12) PATENT**  
**(19) AUSTRALIAN PATENT OFFICE**

**(11) Application No. AU 199870987 B2**  
**(10) Patent No. 739080**

(54) Title  
**Laparoscopic sealant applicator**

(51)<sup>7</sup> International Patent Classification(s)  
**A61B 017/00**

(21) Application No: **199870987**

(22) Application Date: **1998.03.27**

(87) WIPO No: **WO98/42260**

(30) Priority Data

(31) Number	(32) Date	(33) Country
<b>60/042549</b>	<b>1997.03.27</b>	<b>US</b>

(43) Publication Date : **1998.10.20**

(43) Publication Journal Date : **1998.12.03**

(44) Accepted Journal Date : **2001.10.04**

(71) Applicant(s)  
**Bristol-Myers Squibb Company**

(72) Inventor(s)  
**Horace R. Trumbull**

(74) Agent/Attorney  
**PHILLIPS ORMONDE and FITZPATRICK,367 Collins Street,MELBOURNE VIC 3000**

(56) Related Art  
**US 5383899**  
**US 5318524**



IN

<p>(51) International Patent Classification <sup>6</sup> : <b>A61B 17/00</b></p>	<p><b>A1</b></p>	<p>(11) International Publication Number: <b>WO 98/42260</b> (43) International Publication Date: 1 October 1998 (01.10.98)</p>
<p>(21) International Application Number: PCT/US98/06100 (22) International Filing Date: 27 March 1998 (27.03.98) (30) Priority Data: 60/042,549 27 March 1997 (27.03.97) US (71) Applicant: BRISTOL-MYERS SQUIBB COMPANY [US/US]; <del>100 Headquarters Park Drive, Skillman, NJ 08558 (US)</del> 345 Park Avenue, New York New York 10154, USA (72) Inventor: TRUMBULL, Horace, R.; 100 Headquarters Park Drive, Skillman, NJ 08558 (US). (74) Agent: FURMAN, Theodore, R., Jr.; Bristol-Myers Squibb Company, 100 Headquarters Park Drive, Skillman, NJ 08558 (US).</p>		<p>(81) Designated States: AU, CA, IL, JP, MX, NZ, European patent (AT, BE, CH, DE, DK, ES, FI, FR, GB, GR, IE, IT, LU, MC, NL, PT, SE).  <b>Published</b> <i>With international search report.</i></p> 

(54) Title: LAPAROSCOPIC SEALANT APPLICATOR

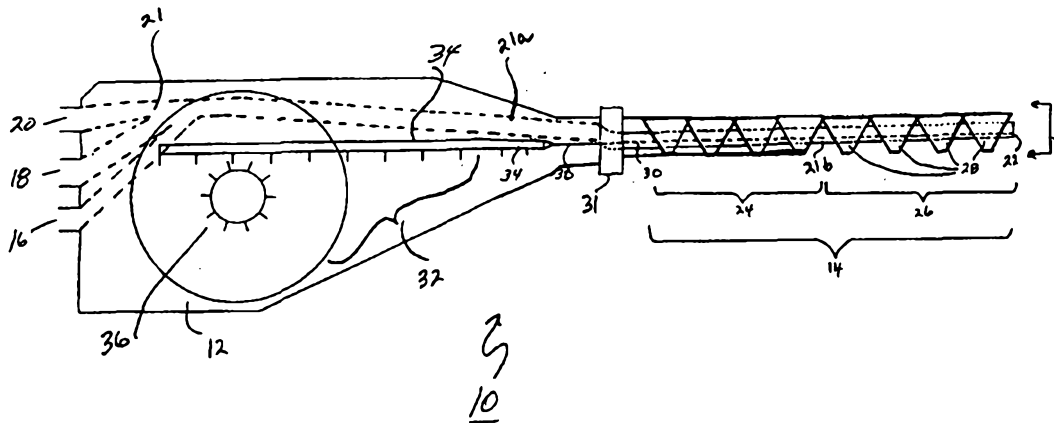

(57) Abstract

A laparoscopic applicator device (10) for the selective directional application of one or more liquids to a surgical site is disclosed. The device (10) comprises a handle (12) with liquid inlets (16, 18, 20) at one end, discrete channels within one or more tubes (21) connecting with said inlets (16, 18, 20) extending through said handle (12) to a nozzle (22), and a dual injection shaft (14) at the nozzle end for inserting the shaft (14) and nozzle (22) through a surgical trocar. The dual shaft (14) comprises a rigid portion immediately adjacent the handle (12) and a flexible portion near the nozzle tip. Means are provided preferably within the handle (12), for the controlled articulation of the flexible shaft (14)/nozzle (22) assembly, thereby providing application of the liquids in a desired direction. The present invention is particularly useful in the application of surgical sealants, e.g., fibrin sealants. Methods of applying such components are also a part of the invention.

## Laparoscopic Sealant Applicator

### 5 Field of the Invention

This invention relates to a laparoscopic sealant applicator wherein a multi-lumen tubing, in fluid communication with a source of sealant, extends a suitable distance beyond a handle so that the tubing can be laparoscopically inserted and articulated in a desired direction to a desired site.

10 PCT/US96/19505, entitled *A Method of Applying a Mixture of Two Liquid Components as well as a Device for Carrying Out the Method*, filed December 6, 1996, discloses an applicator device for applying a surgical sealant, e.g., a fibrin sealant, to a desired site. The applicator consists of a relatively thin multi-lumen tubing which is in fluid communication with sources of sealant components at one end and forms, or is connected to, a spray tip at the other end. In a preferred embodiment, the tubing runs through a handle at or near the spray tip end. The handle is the part of the instrument held by the surgeon to apply the sealant and it may include activating means for actuating the spray from the component sources.

15 Sealants would also be useful in laparoscopic procedures.

20 The above discussion of documents, acts, materials, devices, articles and the like is included in this specification solely for the purpose of providing a context for the present invention. It is not suggested or represented that any or all of these matters formed part of the prior art base or were common general knowledge in the field relevant to the present invention as it existed in Australia before the priority date of each claim of this application.

### Brief Description of the Figures

30

Figure 1 shows a lateral partial cross sectional view of the laparoscopic applicator device of the present invention.

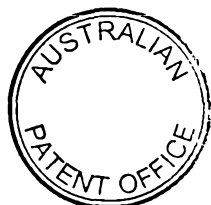

Figures 2a and 2b illustrate the inarticulated and fully articulated arrangement of wedges incorporated into the shaft.

5

### SUMMARY OF THE INVENTION

In accordance with the present invention there is provided an applicator device for the directional laparoscopic delivery of a surgical sealant to a surgical site comprising:

10

a plurality of separate liquid components of a surgical sealant;

a tubing member including a conveyance channel for each of said liquid components, said tubing member having an outlet portion, said outlet portion including a nozzle for dispensing said liquid components, each of said conveyance channels being adapted to convey a liquid component to said nozzle;

15

a handle having said outlet portion of said tubing member extending therefrom;

20

a two-part insertion shaft surrounding at least part of said outlet portion of said tubing member, said two-part insertion shaft including a rigid shaft part secured to said handle, and a flexible articulatable shaft part extending from said rigid shaft part and surrounding at least part of said outlet portion of said tubing member; and

25

directionally controllable, an articulating means extending from said handle through said tubing member for controlling directional articulation of said nozzle dispensing said liquid components to a surgical site.

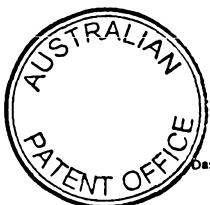

Accordingly a laparoscopic applicator device for the selective directional application of one or more liquids to a surgical site is disclosed. The device comprises a handle with liquid inlets at one end, discrete channels within one or more tubes connecting with said inlets and extending through said handle to a nozzle, and a dual insertion shaft at the nozzle end for inserting the shaft and nozzle through a surgical trocar. The dual shaft comprises a rigid portion immediately adjacent the handle and a flexible portion near the nozzle tip. Means are provided, preferably within the handle, for the controlled articulation of the flexible shaft/nozzle assembly, thereby providing application of the liquids in a desired direction. The present invention is particularly useful in the application of surgical sealants, e.g., fibrin sealants. Methods of applying such components are also a part of the invention.

Throughout the description and claims of this specification, the word "comprise" and variations of the word, such as "comprising" and "comprises", is not intended to exclude other additives, components, integers or steps.

#### Detailed Description of the Preferred Embodiment

The present invention provides a useful device for the laparoscopic application of one or more liquid components to a surgical site. Preferably, the components form a surgical sealant, e.g., a fibrin sealant and the present invention will be further disclosed with regard to fibrin sealants. The device is designed to be utilized through a surgical trocar and facilitates the selective directional application of fibrin sealants via the controlled articulation of a flexible portion of an insertion shaft, including a dispensing tip or spray nozzle.

Figure 1 shows a device 10 of the present invention which

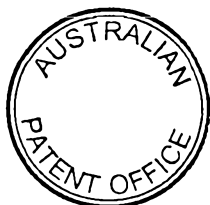

- 3 -

includes a handle 12 and an insertion shaft 14 adapted to be insertable through a surgical trocar. At a first end of the handle 12 are inlets 16, 18, 20 for the one or more liquid or sealant components and optional gas component where spray application is desired. Any number of inlets may be provided. The inlets 16, 18, 20 are adapted to receive the liquid/gas components, and sources (not shown) of the components may be directly adjacent to inlets or may be remote from said inlets but in fluid communication with the inlets via supply tubing. A tubing means 21 extends from the inlets through the handle 12 and insertion shaft 14 to a nozzle or applicator tip 22. This provides for the liquid/gas components to be delivered from the sources to, and out of, the nozzle 22 preferably activated by a separate means controlling the actual flow of liquid and gas. Preferably, the insertion shaft 14 is enclosed with a cladding (not shown) suitable for endoscopic and laparoscopic use. Figure 1 further illustrates that the invention shaft 14 is a two-part assembly comprising a rigid shaft 24 integral with a second end of the handle 12 and a flexible shaft 26 integral with the rigid shaft 24 and preferably coextending and continuous with the tubing means 21 and nozzle 22. The flexible shaft 26 includes a series of hinges 28 which are interconnected so as to enable the bending of the flexible shaft 26 in one direction and straightening of the flexible shaft 26 to its original position. Preferably, the hinges 28 are wedges pivotally interlocked at their tops and disposed laterally along one or both sides of the portion of the tubing means which is included within the flexible shaft 26. The present device further comprises a means for articulating the hinges 28 and flexible shaft through its bent and straightened positions which preferably includes a control

- 4 -

or push/pull wire 30 connected at a first end at or in the nozzle 22 of the tubing means 21 and running through or along the tubing means to a control means 32 within said handle 12 for controlling the articulation of the nozzle 22. If the wire 20 runs through the tubing means 21, then the wire 30 and tubing means intersect at a manifold 31. This provides a juncture at which the wire 30 exits the tubing means 21 to engage the control means 32. Thus, the tubing means would comprise a wireless portion 21a and a wire containing portion 21b in fluid communication with each other via manifold 31. Optionally, the control means can be a remote manually operated or foot pedal-operated system. The control means 32 preferably comprises a rack and pinion assembly comprising a rack 34 (or tooth-containing element) engaged with a rotatable pinion or knob 36, such that rotation of the knob 36 extends or retracts the wire 30 which in turn articulates or straightens the flexible shaft 26. This articulation is illustrated in Figure 2a and 2b. Figure 2a illustrates the relative position of the hinges or wedges 28 when the wire 30 is retracted or withdrawn by the control knob (not shown). Figure 2b illustrates the relative position of the hinges or wedges 28 when the wire (not shown) is extended by the control knob and the wedges and tubing (not shown) are allowed to fold down upon themselves. The degree of extension/retraction dictates the degree of articulation.

Figure 3 shows an end view of the nozzle 22 of the device of the present invention. The nozzle 22 includes outlets 38 corresponding by fluid communication via discrete channels in the tubing means to inlets 16, 18 and 20. The outlets 38 for liquids and optionally a gas for spray are shown arranged within the end wedge 28 which preferably comprises wedges 28a

- 5 -

and 28b on either side of the so-arranged outlets 38 and further includes a bridging portion 28c. Preferably, the outlets 38 and attached end 40 of the wire 30 are incorporated within the preferred single tubing means 21b, although individual tubes can be employed. As can be seen the preferred tubing means 21 comprises the tubing means and having integral channels therein which terminate in the outlets 38 on the nozzle 22. The tube can be of any flexible material, e.g., plastic material, suitable for such medical purposes. The nozzle 22 can be a separate component or can just be the open end of the tube 21b. A cladding 42 can be placed around the entire nozzle/tubing assembly as shown and preferably extends the length of the insertion shaft 14, i.e., the rigid shaft 24 and the flexible shaft 26. The cladding can be of any convenient material utilized in endoscopic and laparoscopic devices.

Preferably, this is a single patient use, disposable device. It is intended that the flexible shaft and the rigid shaft (typically, a total of about 12 cm in length) are the parts of the device which are to be passed into and through the trocar. It is intended that the maximum cross sectional measurement of any part of the rigid or flexible shaft shall be chosen, so that the device can be used with commercially available trocars.

Although any liquid components can be used, the present invention is particularly well-suited for surgical sealant, e.g., fibrin sealant application. A preferred sealant is disclosed by Edwardson et al. In EP 592242 which employs a low pH4 fibrin monomer composition co-applied with a pH10 acetate buffer.



**THE CLAIMS DEFINING THE INVENTION ARE AS FOLLOWS:**

1. An applicator device for the directional laparoscopic delivery of a surgical sealant to a surgical site comprising:

a plurality of separate liquid components of a surgical sealant;

5 a tubing member including a conveyance channel for each of said liquid components, said tubing member having an outlet portion, said outlet portion including a nozzle for dispensing said liquid components, each of said conveyance channels being adapted to convey a liquid component to said nozzle;

10 a handle having said outlet portion of said tubing member extending therefrom;

a two-part insertion shaft surrounding at least part of said outlet portion of said tubing member, said two-part insertion shaft including a rigid shaft part secured to said handle, and a flexible articulatable shaft part extending from  
15 said rigid shaft part and surrounding at least part of said outlet portion of said tubing member; and

directionally controllable, an articulating means extending from said handle through said tubing member for controlling directional articulation of said nozzle dispensing said liquid components to a surgical site.

20

2. The applicator device of claim 1 wherein said flexible shaft part has a length and said directionally controllable. Articulating means comprises:-

(a) a series of interconnected hinges laterally disposed along the  
25 length of said flexible shaft part;

(b) a push/pull wire connected to and extending from said nozzle, through said tubing member and into the handle; and

30 (c) a control member within said handle connected to a second part of said push/pull wire such that actuation of said control member provides for the desired degree of articulation in said flexible shaft part to apply said liquid components in a desired direction.



3. The applicator of claim 2 wherein said hinges comprise wedges of a rigid material disposed along said flexible shaft part.

4. The applicator of claim 2 wherein said control member comprises a rack  
5 and pinion assembly integral with said second end of said push/pull wire and a control knob or activator.

5. The applicator of any one of claims 1 to 4 wherein each of said liquid  
10 components has its own source.

6. The laparoscopic applicator of any one of claims 1 to 5 wherein said  
surgical sealant is a fibrin sealant.

7. The applicator of any one of claims 1 to 6 incorporating a gas to spray  
15 said sealant.

DATED: 3 August, 2001

PHILLIPS ORMONDE & FITZPATRICK

Attorney's for:

BRISTOL-MYERS SQUIBB COMPANY



1/3

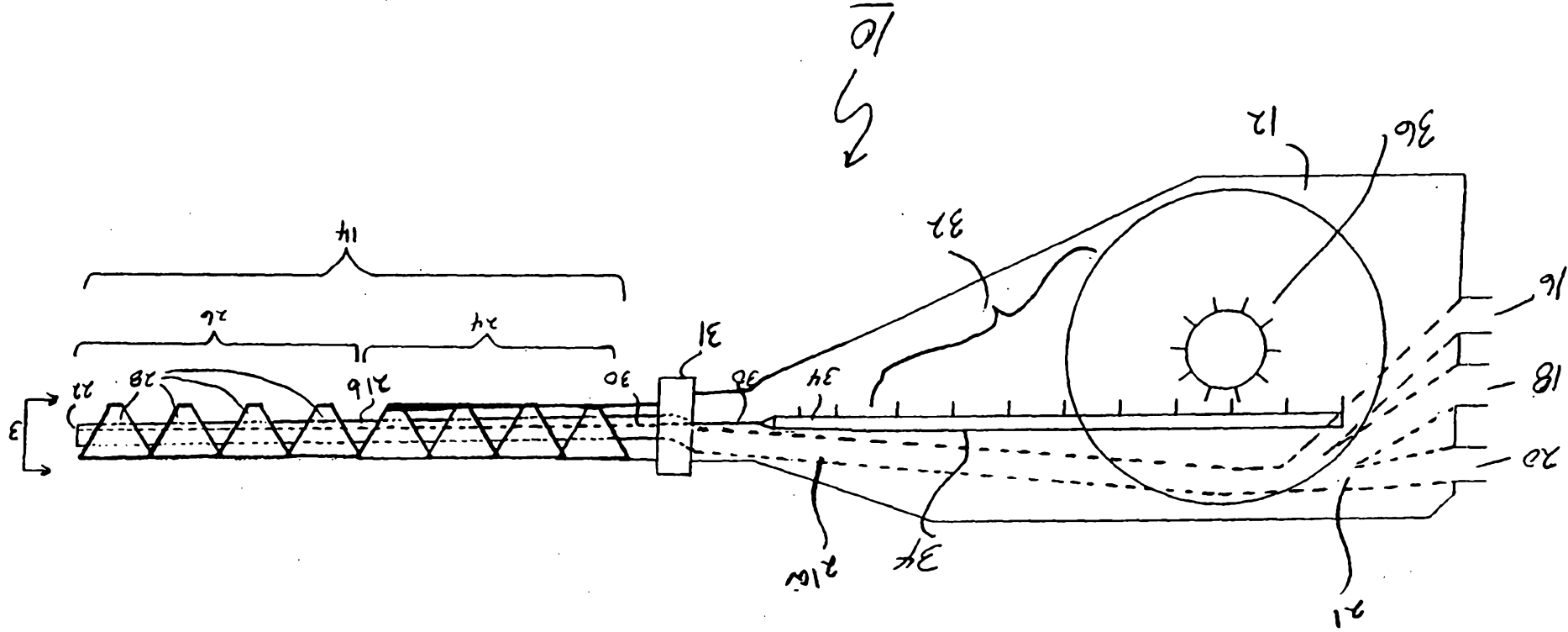

FIGURE 1

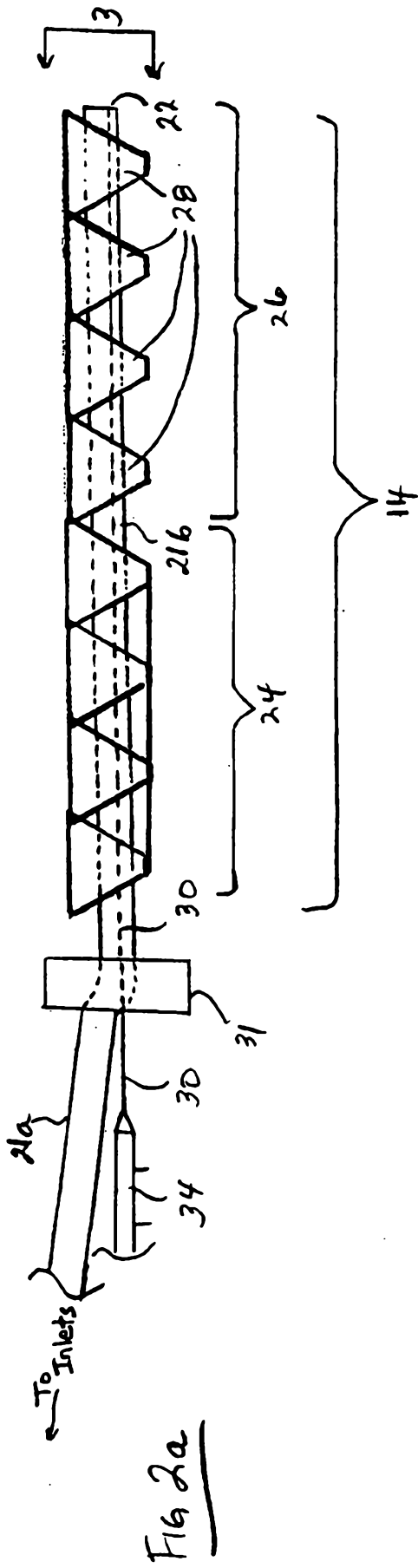

Fig 2a

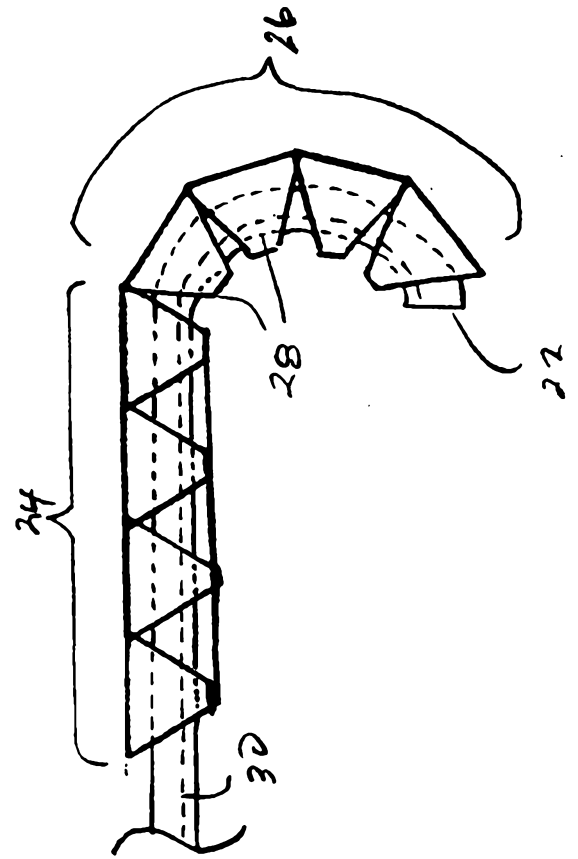

Fig 2b

FIGURE 3

