



US00D634414S

(12) **United States Design Patent**  
**Wolfe et al.**

(10) **Patent No.:** **US D634,414 S**

(45) **Date of Patent:** **\*\* Mar. 15, 2011**

(54) **DEHUMIDIFIER HOUSING**

(75) Inventors: **Kevin A. Wolfe**, Burlington, WA (US);  
**Robert Pendergrass**, Sedro-Woolley,  
WA (US)

(73) Assignee: **Dri-Eaz Products, Inc.**, Burlington, WA  
(US)

(\*\*) Term: **14 Years**

(21) Appl. No.: **29/360,550**

(22) Filed: **Apr. 27, 2010**

(51) **LOC (9) Cl.** ..... **23-04**

(52) **U.S. Cl.** ..... **D23/359**

(58) **Field of Classification Search** ..... D23/364,  
D23/355, 356, 359, 360, 366, 369, 332, 333,  
D23/335, 342, 351, 365; 422/120, 122; 55/356,  
55/473, 504; 96/97; D14/188, 170, 172;  
261/DIG. 17, DIG. 65, DIG. 88, DIG. 31;  
D18/34.6; 62/285; D34/24; D32/21

See application file for complete search history.

(56) **References Cited**

**U.S. PATENT DOCUMENTS**

1,690,108 A	11/1928	Grady
1,870,457 A	8/1932	Kenney
1,894,026 A	1/1933	Derry
2,093,725 A	9/1937	Hull
2,130,092 A	9/1938	Kettering
2,188,975 A	2/1940	Herz
2,623,364 A	12/1952	Munters
D171,429 S	2/1954	Thompson
2,719,596 A	10/1955	Kent et al.
2,758,390 A	8/1956	Munters
2,905,851 A	2/1959	Caussin
2,886,956 A	5/1959	Loveley
2,932,178 A	4/1960	Armstrong et al.
2,959,036 A	11/1960	Mehalick
2,975,609 A	3/1961	Allander et al.
3,000,193 A	9/1961	Crider
3,035,419 A	5/1962	Wigert

3,097,507 A	7/1963	Makuh
3,141,762 A	7/1964	Serck-Hanssen
3,149,479 A	9/1964	Peterson
D212,777 S	11/1968	Anderson
3,621,906 A	11/1971	Leffert
3,623,549 A	11/1971	Smith, Jr.
3,807,493 A	4/1974	Stewart
3,820,581 A	6/1974	Machida et al.

(Continued)

**FOREIGN PATENT DOCUMENTS**

CN 1046384 A 10/1990

(Continued)

**OTHER PUBLICATIONS**

U.S. Appl. No. 12/767,526, filed Apr. 26, 2010, Pendergrass.

(Continued)

*Primary Examiner* — T. Chase Nelson

*Assistant Examiner* — David G Muller

(74) *Attorney, Agent, or Firm* — Perkins Coie LLP

(57) **CLAIM**

The ornamental design for a dehumidifier housing, as shown and described.

**DESCRIPTION**

FIG. 1 is an isometric view of an embodiment of a dehumidifier housing showing my new design.

FIG. 2 is a front elevation view of the dehumidifier housing.

FIG. 3 is a back elevation view of the dehumidifier housing.

FIG. 4 is a right side elevation view of the dehumidifier housing. The right side elevation view is a mirror image of the left side elevation view of the dehumidifier housing.

FIG. 5 is a top plan view of the dehumidifier housing; and,

FIG. 6 is a bottom plan view of the dehumidifier housing.

The features shown in broken lines depict environmental subject matter only and form no part of the claimed design.

**1 Claim, 4 Drawing Sheets**

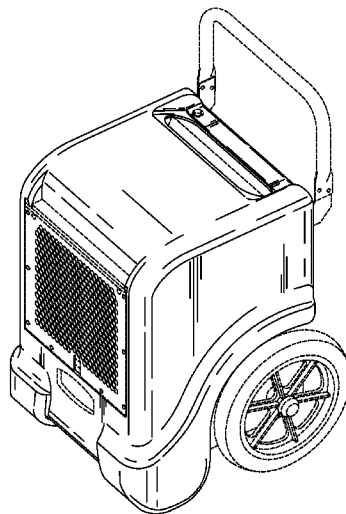

U.S. PATENT DOCUMENTS

3,877,518 A 4/1975 Dreksler  
 3,968,833 A 7/1976 Strindehag et al.  
 4,000,779 A 1/1977 Irwin  
 4,044,820 A 8/1977 Nobles  
 4,091,547 A 5/1978 Leigh  
 4,176,525 A 12/1979 Tucker et al.  
 4,183,399 A 1/1980 Seehausen  
 4,189,848 A 2/1980 Ko et al.  
 D254,566 S 3/1980 Cummins  
 4,259,268 A 3/1981 DiRoss  
 4,280,483 A 7/1981 Schaffer  
 4,295,342 A 10/1981 Parro  
 4,333,517 A 6/1982 Parro  
 4,428,207 A 1/1984 Hall  
 4,452,051 A 6/1984 Berger et al.  
 4,502,286 A 3/1985 Okada et al.  
 4,546,820 A 10/1985 Whipple  
 4,607,498 A 8/1986 Dinh  
 4,615,383 A 10/1986 Hisao  
 4,628,696 A 12/1986 Rodgers  
 4,724,901 A 2/1988 Munekawa  
 4,771,824 A 9/1988 Rojey et al.  
 4,827,733 A 5/1989 Dinh  
 4,921,041 A 5/1990 Akachi  
 D308,414 S 6/1990 Makihara  
 4,938,035 A 7/1990 Dinh  
 4,942,740 A 7/1990 Shaw et al.  
 D310,412 S 9/1990 Fukumoto et al.  
 4,971,139 A 11/1990 Khattar  
 5,031,411 A 7/1991 Gehring et al.  
 5,033,539 A 7/1991 Kohtaka  
 D325,252 S \* 4/1992 Morris et al. .... D23/364  
 5,115,645 A 5/1992 Abraham  
 5,117,651 A 6/1992 Suh  
 5,219,020 A 6/1993 Akachi  
 D337,592 S \* 7/1993 Hider et al. .... D23/332  
 5,265,895 A 11/1993 Barrett  
 5,269,151 A 12/1993 Dinh  
 D343,706 S \* 1/1994 Gurstein .... D32/21  
 5,333,470 A 8/1994 Dinh  
 5,394,040 A 2/1995 Khanh  
 5,404,938 A 4/1995 Dinh  
 D361,178 S 8/1995 Piret  
 5,443,624 A 8/1995 Claesson  
 5,448,897 A 9/1995 Dinh  
 D364,947 S \* 12/1995 Kent et al. .... D32/21  
 D368,770 S 4/1996 Tanner et al.  
 5,548,905 A 8/1996 Kuma et al.  
 5,564,184 A 10/1996 Dinh  
 5,582,246 A 12/1996 Dinh  
 D379,016 S 4/1997 Wilson  
 5,634,353 A 6/1997 Hallin et al.  
 5,684,672 A 11/1997 Karidis et al.  
 5,736,647 A 4/1998 Matsubara et al.  
 D394,499 S \* 5/1998 Bettag et al. .... D23/332  
 5,746,061 A 5/1998 Kramer  
 5,749,415 A 5/1998 Dinh  
 D395,492 S 6/1998 Phillips et al.  
 5,794,453 A 8/1998 Barnwell  
 D402,021 S 12/1998 Allen et al.  
 5,845,702 A 12/1998 Dinh  
 5,890,368 A 4/1999 Lakdawala  
 5,901,565 A 5/1999 Morton, Jr.  
 5,921,315 A 7/1999 Dinh  
 5,953,831 A 9/1999 Yu  
 5,953,926 A 9/1999 Dressler et al.  
 5,992,161 A 11/1999 O'Halloran et al.  
 D419,230 S \* 1/2000 Ciccone .... D23/333  
 D420,473 S \* 2/2000 Shero .... D32/21  
 6,021,644 A 2/2000 Ares et al.  
 6,030,426 A 2/2000 Stopyra et al.  
 6,035,551 A 3/2000 Scheufler et al.  
 D422,351 S 4/2000 Griffin  
 D422,386 S \* 4/2000 Jaros et al. .... D32/21  
 D426,473 S 6/2000 Blackburn  
 D441,161 S \* 4/2001 Shetterly .... D34/24

6,237,352 B1 5/2001 Goodchild  
 D445,116 S \* 7/2001 Evans et al. .... D23/332  
 D453,560 S 2/2002 Van Brunt  
 6,447,586 B1 9/2002 Campbell  
 D465,018 S 10/2002 Gustafsson et al.  
 D480,467 S 10/2003 White  
 6,644,060 B1 11/2003 Dagan  
 6,796,896 B2 9/2004 Laiti  
 D500,848 S 1/2005 Holderfield et al.  
 6,895,774 B1 5/2005 Ares et al.  
 D508,735 S 8/2005 Klein  
 D515,190 S 2/2006 Bartholmey et al.  
 7,194,870 B1 3/2007 O'Brien et al.  
 7,246,503 B1 7/2007 O'Brien et al.  
 7,281,389 B1 10/2007 O'Brien et al.  
 D565,269 S \* 3/2008 Tomasiak et al. .... D32/21  
 D572,356 S \* 7/2008 Harber .... D23/364  
 D612,032 S \* 3/2010 Gildersleeve et al. .... D23/333  
 2005/0011255 A1 1/2005 Weisenberger et al.  
 2005/0011962 A1 1/2005 Weisenberger et al.  
 2005/0066538 A1 3/2005 Goldberg et al.  
 2007/0012060 A1 1/2007 Simons  
 2008/0028776 A1 2/2008 O'Brien et al.  
 2008/0223050 A1 9/2008 Bruders et al.  
 2010/0125367 A1 5/2010 Burton et al.

FOREIGN PATENT DOCUMENTS

EP 0046528 A1 3/1982  
 EP 830554 A1 3/1998  
 FR 2687464 A1 8/1993  
 GB 1311232 A 3/1973  
 GB 2006950 A 5/1979  
 JP 60188795 A 9/1985  
 JP 61164622 A 7/1986  
 JP 62023418 A 1/1987  
 JP 01041792 A 2/1989  
 JP 6111591 A 4/1994  
 JP 08135999 A 5/1996  
 JP 09239230 A 9/1997  
 WO WO-9112476 A1 8/1991  
 WO WO-9641111 A1 12/1996  
 WO WO-2008057647 A2 5/2008

OTHER PUBLICATIONS

"Air Conditioner/Dehumidifier," abstract from Spinoff 1986 article, facsimile dated Nov. 29, 1999, 2 pages.  
 "DrizAir 2400 Dehumidifier: Introduced in Aug. Of 1998 . . .", from web site, <<http://www.dri-eaz.com/2400.htm>>, Jan. 10, 2000, 2 pages.  
 Dri-Eaz, "2002 Product Catalog," Jan. 1, 2002, 7 pages.  
 Dri-Eaz, "Driz-Air 2400 Captures Design Award," <<http://www.dri-eaz.com/newsreleases/newsrelease999.html>>, internet accessed on Jan. 10, 2000, 2 pages.  
 Dri-Eaz, "DrizAir 120 Dehumidifier-Model Comparisons," undated, 4 pages.  
 Dri-Eaz, "DrizAir 1200 Dehumidifier," 2000, 3 pages.  
 Dri-Eaz, Product Catalog, Jan. 1, 2003, Burlington, Washington, U.S., 3 pages.  
 Hodnell, Charles, "Wrap-Around Heat Pipe Makes Its Debut!" Hot Line Newsletter, vol. 15, No. 1, Mar. 1995, 2 pages.  
 Johannesen, R., et al., "Efficient Humidity Control with Heat Pipes," University of Florida-Florida Cooperative Extension Service, Fact Sheet, Dec. 1991, 7 pages.  
 Jon-Don; Gale Force Air Mover from Dry-Air at Jon-Don; www.jondon.com/galeforce/; Mar. 2003, 3 pages.  
 New Release, "Dri-Eaz Products Introduces Rotomolded Dehumidifier", Aug. 27, 1998, from web site, <<http://www.dri-eaz/newsreleases898.html>>, 3 pages.  
 Tropic Kool, "What are Heat Pipes?" <<http://tropickool.com/heat-pipes.html>>, internet accessed on Nov. 29, 1999, 6 pages.  
 Drieaz, "Complete Drying Solutions for Restorative Drying Professionals," 2000, 3 pages.

\* cited by examiner

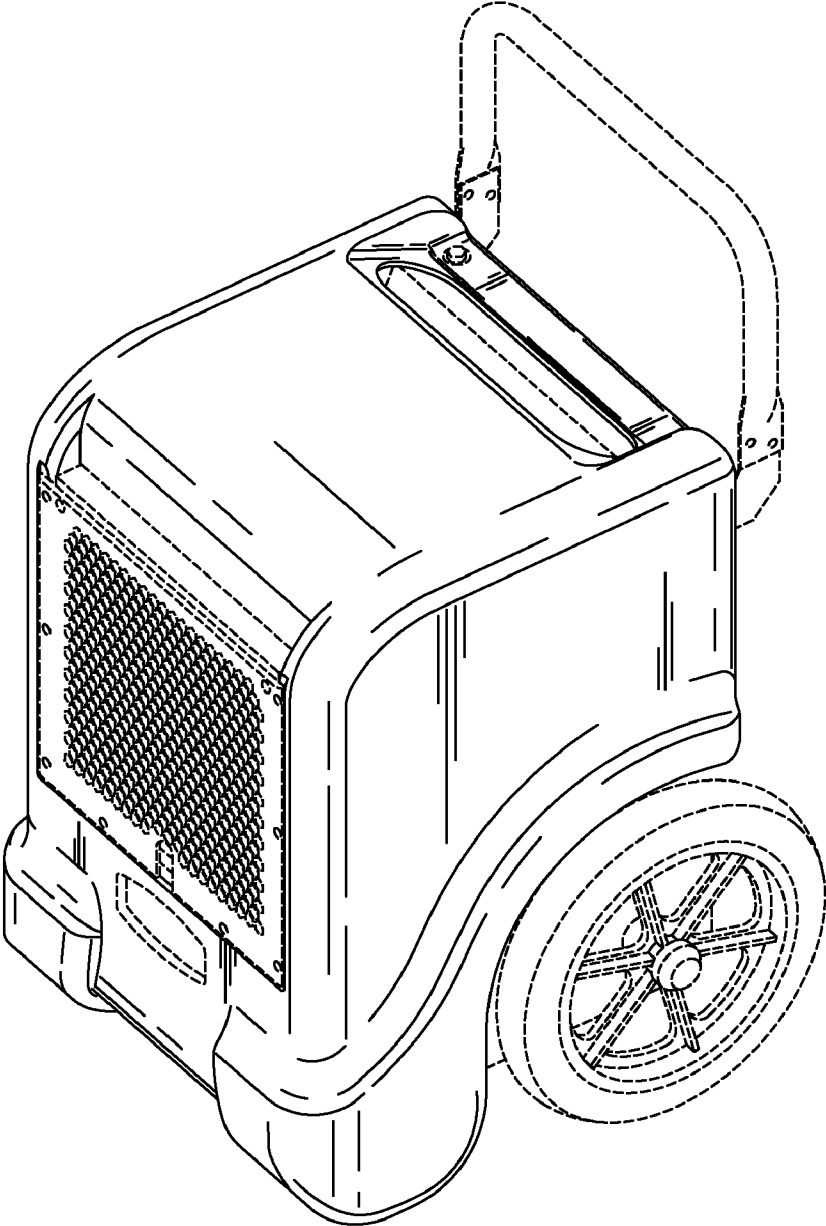

*Fig. 1*

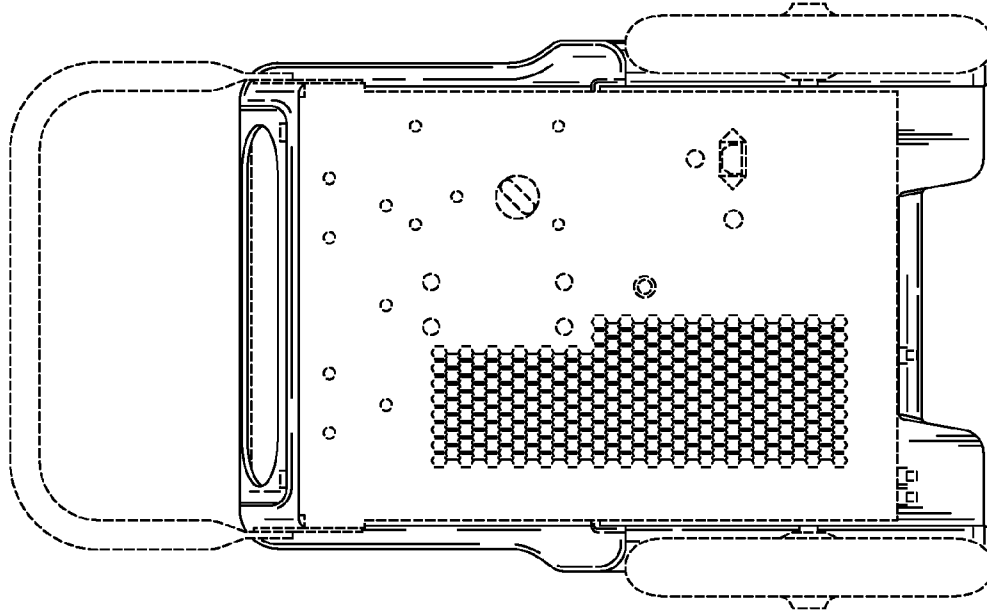

*Fig. 3*

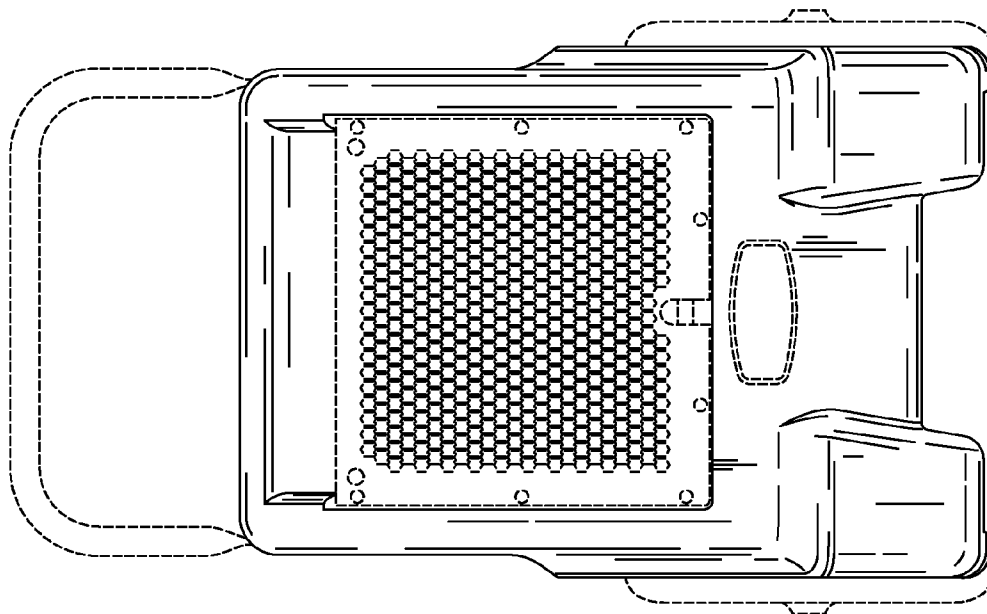

*Fig. 2*

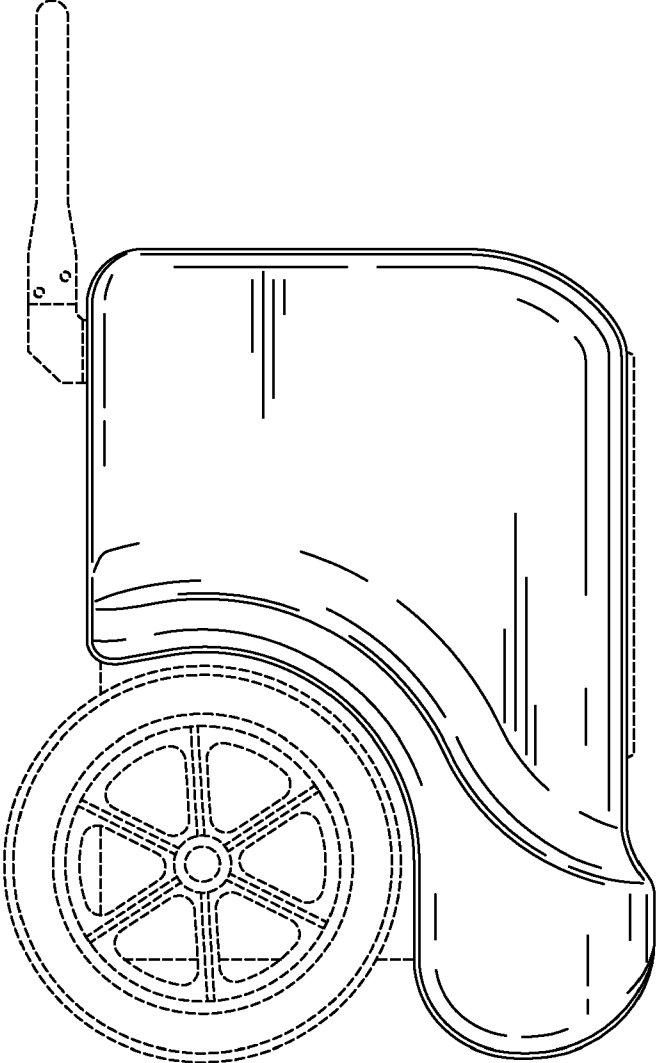

*Fig. 4*

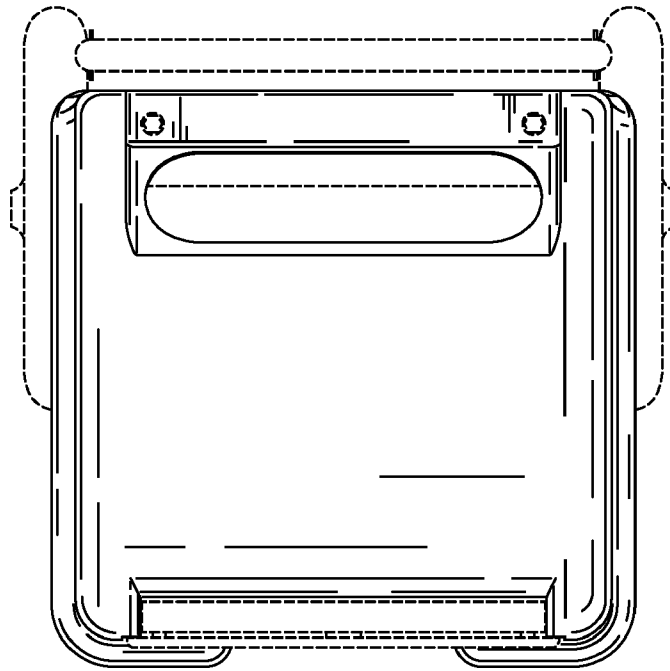

*Fig. 5*

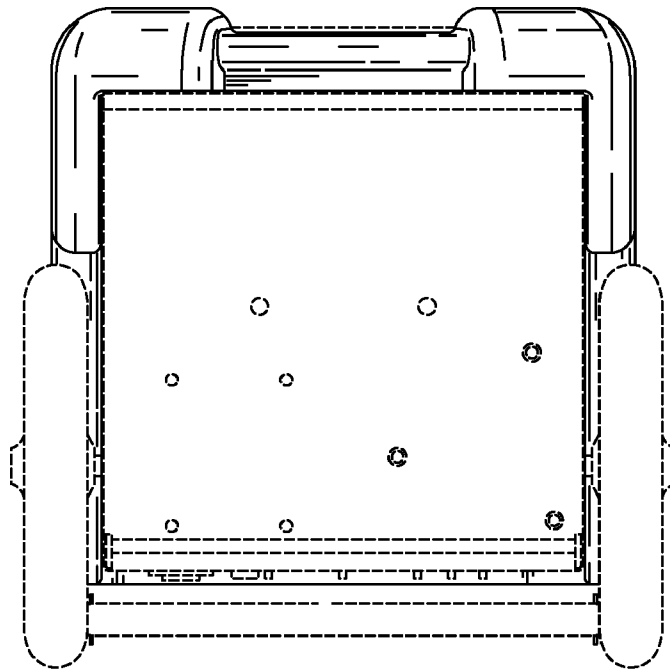

*Fig. 6*