

A. RÓTH.
 DISH CARRIER.
 APPLICATION FILED FEB. 24, 1915.

1,167,934.

Patented Jan. 11, 1916.
 2 SHEETS—SHEET 1.

Fig. 1.

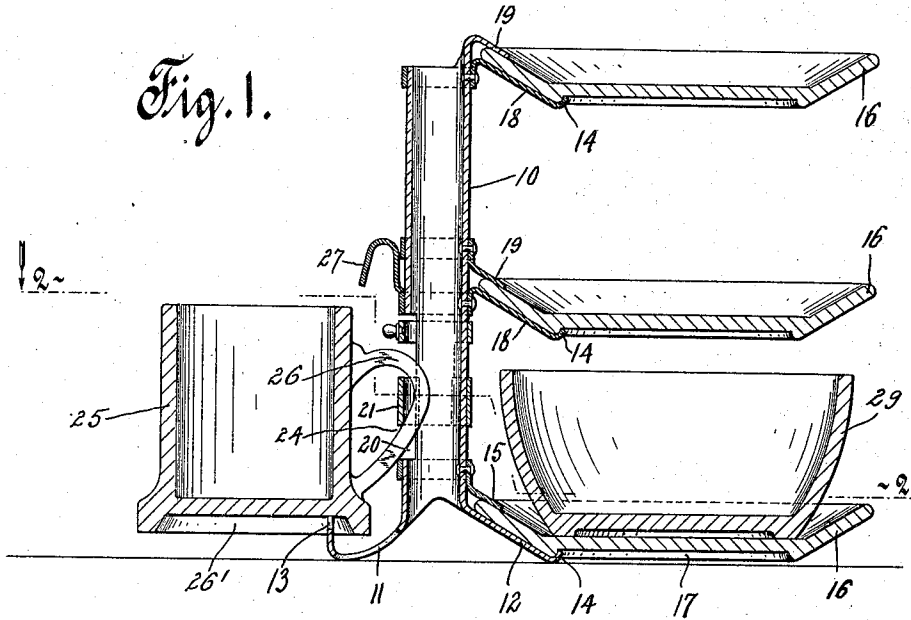

Fig. 2.

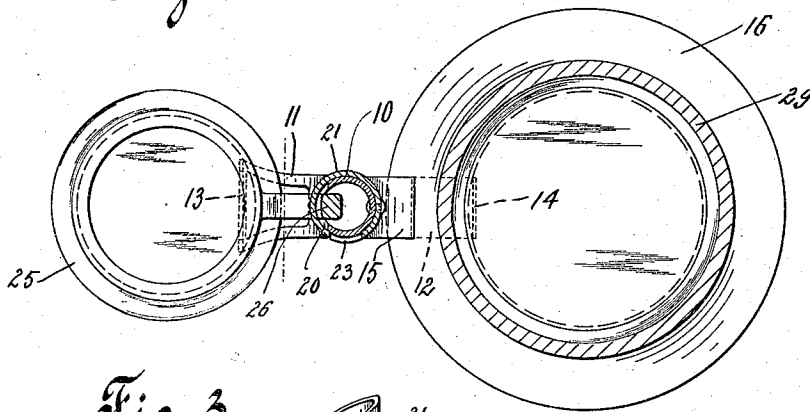
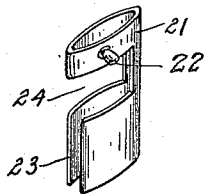

Fig. 3.



WITNESSES
S. Brane.
S. Birnbaum

INVENTOR
A. Roth
 BY
Samuel Herzog
 his ATTORNEY

A. RÓTH.
DISH CARRIER.
APPLICATION FILED FEB. 24, 1915.

1,167,934.

Patented Jan. 11, 1916.
2 SHEETS—SHEET 2.

Fig. 4.

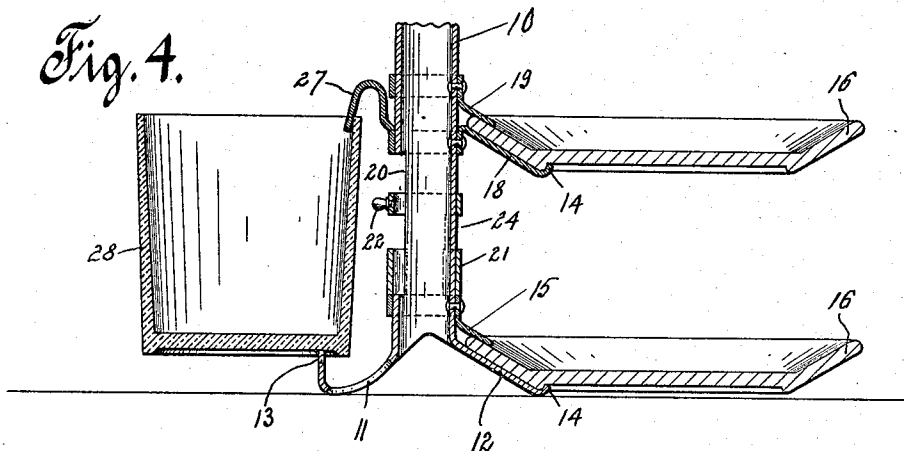
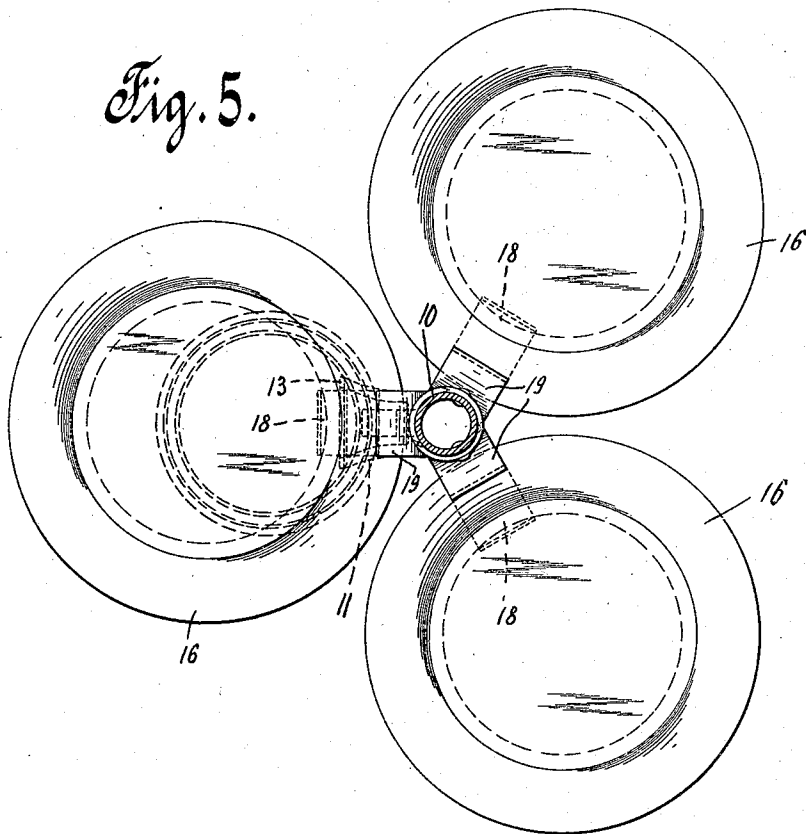

Fig. 5.



WITNESSES
E. Frane.
S. Birnbaum

INVENTOR
A. Róth
BY
Sigmund Herzog
his ATTORNEY

UNITED STATES PATENT OFFICE.

ANDOR RÓTH, OF NEW YORK, N. Y., ASSIGNOR OF ONE-HALF TO THEODORE FREUND,
OF NEW YORK, N. Y.

DISH-CARRIER.

1,167,934.

Specification of Letters Patent.

Patented Jan. 11, 1916.

Application filed February 24, 1915. Serial No. 10,272.

To all whom it may concern:

Be it known that I, ANDOR RÓTH, a subject of the King of Hungary, and a resident of the city of New York, in the county of New York and State of New York, have invented certain new and useful Improvements in Dish-Carriers, of which the following is a specification.

The present invention relates to dish-carriers.

The invention is particularly adapted for use in lunch rooms where the customers or purchasers are served at a counter, and carry the cups, saucers, plates and other dishes, containing food and drinks, to their tables or like supports. It is obvious that the ordinary purchaser cannot carry more than two plates or similar dishes at a time, and is thus compelled to go back and forth several times for the purpose of gathering the eatables.

It is one of the objects of the present invention to provide a portable means for carrying safely and conveniently at one time a plurality of dishes holding food and drink.

Another object of the invention is to produce a device of this type which is simple in construction, efficient in operation, and on which the dishes may be carried without dropping the same or spilling their contents.

With these and other objects in view, which will more fully appear as the nature of the invention is better understood, the same consists in the combination, arrangement and construction of parts hereinafter fully described, pointed out in the appended claims and illustrated in the accompanying drawings, it being understood that many changes may be made in the size and proportion of the several parts and details of construction within the scope of the appended claims without departing from the spirit or sacrificing any of the advantages of the invention.

Two of the many possible embodiments of the invention are illustrated in the accompanying drawings, in which:—

Figure 1 is a vertical section taken through a dish carrier constructed in accordance with the present invention, holding a plurality of dishes; Fig. 2 is a section taken on line 2—2 of Fig. 1; Fig. 3 is a perspective view of a detail of construction; Fig. 4 is a section taken through a portion of the device shown in Fig. 1, with other dishes thereon; and

Fig. 5 is a horizontal section taken through a modification of the invention.

Referring now more particularly to Figs. 1 to 4, inclusive, the carrier comprises a bar 10 in the form of a tubular body, which is made, preferably, of metal and is adapted to rest upon two legs, denoted by the numerals 11 and 12. These legs may be made integral with the body. The leg 11 may be of any suitable shape, and is provided with an upwardly extending projection 13 for a purpose hereinafter to be described. The leg 12 is bent at an angle to the longitudinal axis of the body 10, is straight throughout its length, its free end carrying a lug 14 which is bent upwardly out of the plane of the leg, substantially at right angles thereto. Owing to its length, the leg 12 is somewhat resilient and forms, in cooperation with a clip 15, that is attached by rivets, or otherwise, to the tubular body 10, a support for a plate or saucer 16. The clip 15 extends in parallel relation to the leg 12, but is considerably shorter, as clearly shown in Fig. 1 of the drawings. The side of the saucer or plate 16 rests throughout its length upon the leg 12, the clip 15 engaging the upper face thereof, and the lug 14 being seated in the recess 17 in the bottom of the plate or saucer. Preferably at equal intervals there is attached to the body 10 above and in alinement with the leg 12 a plurality of supporting strips 18, which are similar in configuration to that of the leg 12, and each has associated therewith a clip 19, similar in construction and operation to those of the clip 15.

Above the leg 11 there is provided in the body 10 a vertically extending slot 20. With this slot coöperates a sleeve 21, which is shiftably and rotatably mounted upon the tubular body 10, and provided with a finger-piece 22 to facilitate the operation thereof. This sleeve has a longitudinal slot 23 in its side and a recess 24, for the purpose presently to be described. When the sleeve is turned so that its longitudinal slot 23 registers with the slot 20 in the wall of the tubular body 10, a cup 25 can be placed upon the projection 13, the handle 26 of said cup projecting then through the registering slots 23 and 20 and through the recess 24 into the tubular body 10. When then the sleeve is turned so that the slots 23 and 20 are brought out of alinement, the sleeve holds

the cup firmly in position upon the carrier. The recess 24 permits the sleeve to be turned into such position. The projection 13 upon the leg 11 rests against the underface of the bottom of the cup, and is preferably seated in the recess 26' in said underface.

With the projection 13 of the leg 11 is adapted to cooperate an inverted substantially U-shaped member 27, that is fixedly attached to the body 10 in alinement with the projection 13, and at a substantial distance above the same. The U-shaped member 27 is adapted to abut against the inner face of the cylindrical wall of a drinking glass or similar article 28 resting upon the projection 13, as clearly shown in Fig. 4 of the drawings.

The operation of this device is obvious from the foregoing. The saucers or plates containing food are placed one after the other upon the supporting strips 18 and leg 12. These supporting strips and the leg 12 are somewhat resilient, and are thus adapted to be swung, in inserting the plates and saucers, away from the clips 19 and 15, swinging back into place afterward. The plates and saucers are firmly held upon the carrier, the lugs 14 upon the supporting strips and the leg 12 preventing a sidewise motion of said saucers and plates. In placing these dishes upon the carrier, the latter is held by one hand, and the dishes, one after the other, taken hold of with the other hand and forced in between the cooperating supporting strips and clips. A bowl 29, or a similar dish, may be placed upon the plates or saucers. If a cup, containing coffee or another beverage, is to be placed upon the carrier, the handle of said cup is inserted in the manner above described through the slot 20 into the body 10, and the sleeve 21 actuated in the manner abovementioned. On the other hand, if a glass of water is to be placed upon the carrier, the inverted U-shaped body 27 is inserted into the mouth of said glass, and the latter shifted upward until the projection 13 of the leg 11 is adapted to enter the recess in the bottom of said glass. After this the glass is lowered until its bottom rests upon the projection 13.

The modification shown in Fig. 5 of the drawings is especially adapted for waiters or other persons serving food and drinks in restaurants. In the construction shown in Fig. 1 of the drawings the supporting strips 18 are singly placed upon the tubular body 10. In the modification shown in Fig. 5 of the drawings the supporting strips 18 are disposed in clusters around the tubular body 10, that is to say there is a plurality of supporting strips arranged in each of a series of horizontal planes, thereby greatly increasing the capacity of the carrier.

It is to be observed that, inasmuch as the supporting strips 18 and the legs 12 are in-

clined, the plates and saucers will be kept in horizontal positions, so that the contents of the cups, plates, saucers, bowls, etc. will be prevented from being spilled. Since the supporting strips and the leg 12 are resilient, the plates and saucers can be easily inserted between the supporting strips and legs, and the clips cooperating therewith, and equally well removed therefrom.

It should be noted that the device shown in Fig. 5 of the drawings can also be used for collecting empty dishes in restaurants and the like, a great number of the same being adapted to be carried at one time thereon.

What I claim is:—

1. In a device for carrying food and drink serving articles, the combination with a bar, of a plurality of resilient supporting strips fixedly attached thereto at an angle to the longitudinal axis of said bar, said supporting strips being arranged in clusters and each being provided with a lug extending substantially at right angles to the plane thereof, and a clip associated with each supporting strip, said clips being rigidly attached to said bar and extending each in parallel relation to the respective supporting strips but being shorter than said supporting strips.

2. In a device for carrying food and drink serving articles, the combination with a tubular body having a longitudinal slot, of a plurality of parallel resilient supporting strips fixedly attached thereto at an angle to the longitudinal axis of said tubular body, each of said supporting strips being provided with a lug extending substantially at right angles to the plane thereof, a clip associated with each supporting strip, said clips being rigidly attached to said tubular body and extending in parallel relation to said supporting strips but being substantially shorter than said supporting strips, and a sleeve shiftably and rotatably disposed upon said tubular body, said sleeve encircling the slotted portion of said body and having a slot and a recess above said slot, said recess extending substantially in rear of the slot in said sleeve, and both the slot and recess in said sleeve being adapted to register with the slot in said tubular body.

3. In a device for carrying food and drink serving articles, the combination with a tubular body having a longitudinal slot, of a plurality of parallel resilient supporting strips fixedly attached thereto at an angle to the longitudinal axis of said tubular body, each of said supporting strips being provided with a lug extending substantially at right angles to the plane thereof, a clip associated with each supporting strip, said clips being rigidly attached to said tubular body and extending in parallel relation to said supporting strips but being substan-

5 tially shorter than said supporting strips,
 a sleeve shiftably and rotatably disposed
 upon said tubular body, said sleeve encir-
 cling the slotted portion of said body and
 10 having a slot and a recess above said slot,
 said recess extending substantially in rear
 of the slot in said sleeve, and both the slot
 and recess in said sleeve being adapted to
 register with the slot in said tubular body,
 and a projection upon said tubular body in
 15 alinement with and below the slot therein.

4. In a device for carrying food and drink
 serving articles, the combination with a
 tubular body having a longitudinal slot, of
 15 a plurality of parallel resilient supporting
 strips fixedly attached thereto at an angle to
 the longitudinal axis of said tubular body,
 each of said supporting strips being pro-
 vided with a lug extending substantially at
 20 right angles to the plane thereof, a clip as-
 sociated with each supporting strip, said
 clips being rigidly attached to said tubular
 body and extending in parallel relation to

said supporting strips but being substan-
 tially shorter than said supporting strips, a 25
 sleeve shiftable and rotatably disposed upon
 said tubular body, said sleeve encircling the
 slotted portion of said body and having a
 slot and a recess above said slot, said recess
 extending substantially in rear of the slot 30
 in said sleeve, and both the slot and recess
 in said sleeve being adapted to register with
 the slot in said tubular body, a projection
 upon said tubular body in alinement with
 and below the slot therein, and an inverted 35
 U-shaped member attached to said body in
 alinement with said projection and above
 the slotted portion of said tubular body.

Signed at New York, in the county of
 New York and State of New York, this 23rd 40
 day of Feb., A. D. 1915.

ANDOR RÓTH.

Witnesses:

SIGMOND HERZOG,
 THEO. FREUND.

Copies of this patent may be obtained for five cents each, by addressing the "Commissioner of Patents,
 Washington, D. C."