



INTERNATIONAL APPLICATION PUBLISHED UNDER THE PATENT COOPERATION TREATY (PCT)

<p>(51) International Patent Classification ⁷ : B63B 21/50, 35/44</p>	<p>A1</p>	<p>(11) International Publication Number: WO 00/27692 (43) International Publication Date: 18 May 2000 (18.05.00)</p>
<p>(21) International Application Number: PCT/NO99/00327 (22) International Filing Date: 26 October 1999 (26.10.99) (30) Priority Data: 19984968 26 October 1998 (26.10.98) NO (71) Applicant (for all designated States except US): LUND, MOHR & GIÆVER-ENGER MARIN AS [NO/NO]; Solheimsgaten 9c, N-5058 Bergen (NO). (72) Inventors; and (75) Inventors/Applicants (for US only): KJERSEM, Geir [NO/NO]; Våkleiva 124, N-5155 Bønes (NO). RAAB, Bengt, Erik [NO/NO]; Kjødalen 31, N-5918 Frekhaug (NO). (74) Agent: AS BERGEN PATENTKONTOR; C. Sundtsgt. 36, N-5004 Bergen (NO).</p>		<p>(81) Designated States: AE, AL, AM, AT, AU, AZ, BA, BB, BG, BR, BY, CA, CH, CN, CR, CU, CZ, DE, DK, DM, EE, ES, FI, GB, GD, GE, GH, GM, HR, HU, ID, IL, IN, IS, JP, KE, KG, KP, KR, KZ, LC, LK, LR, LS, LT, LU, LV, MA, MD, MG, MK, MN, MW, MX, NO, NZ, PL, PT, RO, RU, SD, SE, SG, SI, SK, SL, TJ, TM, TR, TT, TZ, UA, UG, US, UZ, VN, YU, ZA, ZW, ARIPO patent (GH, GM, KE, LS, MW, SD, SL, SZ, TZ, UG, ZW), Eurasian patent (AM, AZ, BY, KG, KZ, MD, RU, TJ, TM), European patent (AT, BE, CH, CY, DE, DK, ES, FI, FR, GB, GR, IE, IT, LU, MC, NL, PT, SE), OAPI patent (BF, BJ, CF, CG, CI, CM, GA, GN, GW, ML, MR, NE, SN, TD, TG).</p> <p>Published With international search report. In English translation (filed in Norwegian).</p>

(54) Title: DEVICE FOR POSITIONING OF VESSELS

(57) Abstract

There is disclosed a device for positioning of vessels (1), such as ships, barges, semi-subs or the like, relative to the effecting of an activity from the vessel, such as drilling, production (4) or geological investigations and the like, in connection with the recovery or transport of hydrocarbons at sea. The device is characterised by a floating float construction (2) whose vertical position in the sea can be regulated, and is anchored to the sea bottom via a number of anchoring lines (3), and if desired can be turned horizontally, that the vessel (1) is adapted for positioning adjacent to the float (2), and that the float comprises means for detachably fixing the vessel (1) to the float (2), so that they move as a unit.

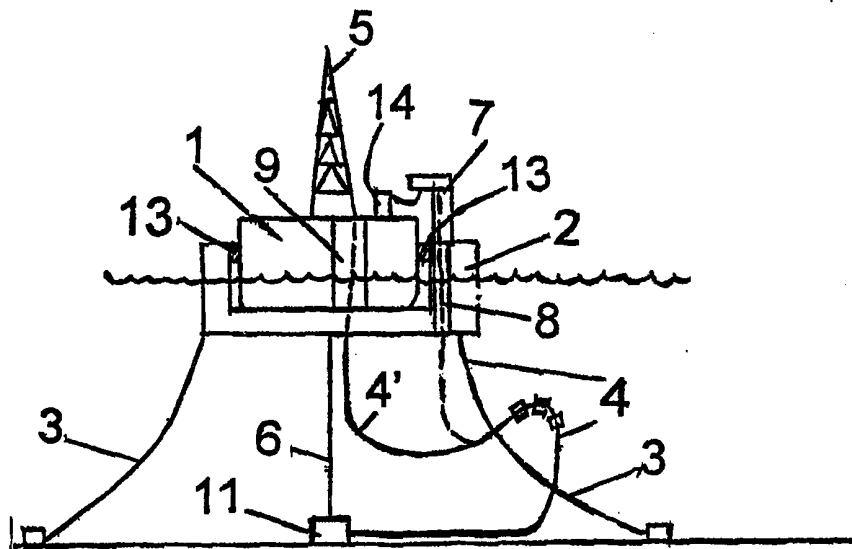

FOR THE PURPOSES OF INFORMATION ONLY

Codes used to identify States party to the PCT on the front pages of pamphlets publishing international applications under the PCT.

AL	Albania	ES	Spain	LS	Lesotho	SI	Slovenia
AM	Armenia	FI	Finland	LT	Lithuania	SK	Slovakia
AT	Austria	FR	France	LU	Luxembourg	SN	Senegal
AU	Australia	GA	Gabon	LV	Latvia	SZ	Swaziland
AZ	Azerbaijan	GB	United Kingdom	MC	Monaco	TD	Chad
BA	Bosnia and Herzegovina	GE	Georgia	MD	Republic of Moldova	TG	Togo
BB	Barbados	GH	Ghana	MG	Madagascar	TJ	Tajikistan
BE	Belgium	GN	Guinea	MK	The former Yugoslav Republic of Macedonia	TM	Turkmenistan
BF	Burkina Faso	GR	Greece	ML	Mali	TR	Turkey
BG	Bulgaria	HU	Hungary	MN	Mongolia	TT	Trinidad and Tobago
BJ	Benin	IE	Ireland	MR	Mauritania	UA	Ukraine
BR	Brazil	IL	Israel	MW	Malawi	UG	Uganda
BY	Belarus	IS	Iceland	MX	Mexico	US	United States of America
CA	Canada	IT	Italy	NE	Niger	UZ	Uzbekistan
CF	Central African Republic	JP	Japan	NL	Netherlands	VN	Viet Nam
CG	Congo	KE	Kenya	NO	Norway	YU	Yugoslavia
CH	Switzerland	KG	Kyrgyzstan	NZ	New Zealand	ZW	Zimbabwe
CI	Côte d'Ivoire	KP	Democratic People's Republic of Korea	PL	Poland		
CM	Cameroon	KR	Republic of Korea	PT	Portugal		
CN	China	KZ	Kazakstan	RO	Romania		
CU	Cuba	LC	Saint Lucia	RU	Russian Federation		
CZ	Czech Republic	LI	Liechtenstein	SD	Sudan		
DE	Germany	LK	Sri Lanka	SE	Sweden		
DK	Denmark	LR	Liberia	SG	Singapore		
EE	Estonia						

DEVICE FOR POSITIONING OF VESSELS.

The present invention relates to a device for positioning of vessels, such as ships, barge, semi-sub or the like, relative to the effecting of an activity from the vessel, such as drilling, production or geological investigations and the like, in connection with the recovery or transport of hydrocarbons at sea.

The invention has to do with all the operations which are carried out in connection with searching for, drilling, production and transport of hydrocarbons at sea, and especially where these operations are carried out with the point of origin in a vessel, that is to say a drilling vessel, a production vessel or a vessel which can combine these operations.

The invention is particularly intended for a production vessel which is based on a conventional ships' hull, but the invention is also very well-suited when the production vessel is designed as a barge, as a submersible rig or as another type of floating construction which can be used for the afore-mentioned operations. The term production vessel which is used in this description covers therefore various designs of the production ship per se.

It is known that oil and gas can be produced by conveying it up to the production vessel from production wells via dedicated risers. The risers will preferably be flexible, but can also if desired be prestressed over the whole or portions of the length. The wells are controlled

by means of wellhead trees which are located above or below water, dependent upon the solution chosen for the risers. The vessel is anchored to the sea bottom with the necessary number of mooring lines. The vessel can with advantage be
5 designed so that it can resist the weather both forward and astern.

A foremost object of the invention is to provide a novel device in connection with such an installation comprising a production vessel and which makes possible the
10 production of oil, gas plus the transport thereof, and if desired drilling, and where the production vessel can easily, rapidly and under complete control be coupled to or uncoupled from the production systems for oil and gas, if
15 desired the drilling systems on the ocean bottom, at the same time as one maintains complete control over the temporarily disconnected pipes, cable control systems, etc. which constitute parts of the production systems.

Rapid and controllable uncoupling of the aforementioned equipment can be desirable, and in some instances
20 imperative, in the waters where the weather conditions are often severe and rapidly changing. With the invention the aim is to produce a system so that production vessels can be made substantially cheaper than if one had to design the vessel and mooring systems for the very brief periods
25 having extreme weather conditions, in that the vessel is uncoupled from the production systems and if desired can be removed from the heavy weather region. When the heavy weather has passed it is desirable that the vessel can return to the area and by means of the invention the
30 production rapidly resumed after a short coupling-up time. Weather statistics from the North Sea and the northern Atlantic show that the extreme weather conditions which require that production must be closed down, are very brief and infrequent, often limited to a maximum of 0 - 1 day per
35 year, or 0 - 0.25% of the time on a yearly basis. Permanent production devices must however tolerate these extreme weather conditions. Design requirements associated with the 100 year sea are a typical example of factors which involve

increased building costs, that is to say for a condition which viewed statistically will only occur each 100 years.

Floating production and drilling devices at sea are usually based on semi-sub (half submersible) or on
5 conventional vessel hulls. In severe weather areas there are several examples of production installations placed on a semi-sub. These have good sea characteristics, but often take little deck cargo. In addition examples are present of combining drilling and production from semi-sub.
10 Production ships are usual over the whole world, because of good space on board and the possibilities for storage of the oil. However no production ships have drilling installations on board because conventional production ships are dependent upon being able to rotate a lot in
15 order to maintain the bow up towards the weather.

Conventional production ships are equipped with a " turret ", a combined anchoring swivel and rotating tower which the vessel can rotate around. This is due to a desire to maintain the vessel up towards the weather in order to
20 minimalise the forces on the vessel. This turret is large, heavy and expensive and involves complicated pipes and cable penetration because of the need for rotation around the axis of the turret. If in addition one desires to install drilling machinery on board the production vessel,
25 it is proposed inter alia to install the drilling machinery above the axis of rotation, as is described in the patent specifications GB 2231356 and NO 171958. However this is a very complicated solution, and has been considered as undesirable because of the safety risk. Statistics show
30 that the drilling region is one of the most dangerous areas on an offshore installation. Safety will not be enhanced if flexible production pipes which contain hydrocarbons are drawn up into the drilling operation zone.

Norwegian Patent Specification NO 970448 describes a
35 vessel with the possibility of two bows, so that the need for rotation is reduced and the drilling machinery can be installed on board at a distance from the region for production pipes. This makes possible being able to anchor

the vessel without the use of the turret, at the same time as drawing in of the production risers can take place outside the drilling region. In addition it is possible to simplify or eliminate the use of the turret, swivels, cable drums or the like in connection with the drawing in of the risers because the rotation of the vessel is limited. A limitation with this solution emerges if the weather shifts outside the limitations which are produced in the angle of rotation. This applies particularly for regions where the direction of the weather in extreme conditions shifts rapidly and unforeseeably, such as for example in passing cyclones.

Another solution with combining drilling and production in a vessel solution is indicated in NO 171957 (Single Buoy Moorings Inc.). Here the vessel functions only as production and storage, while the swivel, pull up of risers and drilling systems are placed on board on a tension leg platform. The solution is very expensive because one is dependent upon a complicated swivel and an expensive tension leg platform. The chosen solution will also produce complicated solutions with a view to personnel changes, pipe connections and cables between the two installations because both installations move fairly freely relative to each other. Besides the solution is little suited to extreme weather conditions where the movements between the floating constructions of different design and volume will move very differently and in part unforeseeably, at the same time as the solution becomes complicated if the weather shifts beyond the angle of rotation.

A series of solutions for production, loading and transport of hydrocarbons at sea, is based on mooring between ship and isolated positioned buoys.

Floating dry docks for the repair of ships, are well known, and in use in many shipyards. Such dry docks must however have great ballast capacity in order to be able to lift a ship which is placed within the dock, upwards over the surface of the sea/water. These dock constructions will

thus have a displacement which is often many times larger than the displacement of the vessel which is to be drained. Therefore such docks are suited for protected waters, that is to say in harbours or sheltered waters. If this type of dock should be employed at sea for oil production, the environmental forces on this dock (and thereby the stresses on the construction per se and its moorings) would become formidable, and much greater than if the vessel was anchored alone.

10 It is an object of the present invention to provide a construction for a production vessel, so that the vessel can be rapidly, safely and controllably connected to and disconnected from the production systems for oil and gas, as well as the systems for anchoring.

15 At the same time it is an object of the invention to substantially simplify the use of rotating, mechanical connections like turrets, swivels, etc. between production vessels and production systems relative to current practice, or preferably that this is made unnecessary.

20 The device according to the invention is characterised in that the device comprises a floating float construction whose vertical position in the sea can be regulated, and is anchored to the sea bottom via a number of anchoring lines, and if necessary can be turned in a horizontal plane, that the vessel is adapted for positioning adjacent to the float construction, and that the float construction comprises means for detachably fixing the vessel to the float construction, so that the units move as one unit.

30 Further features of the inventive device are specified in the dependent claims 2-14.

35 With the present invention a device is provided which gives the possibility for a rapid, safe and controllable disconnection and later a correspondingly rapid connection between vessel/ship and production systems so that there are possibilities of substantially reducing the effects and consequences of the worst, but brief, periods of heavy weather in the production of oil and gas at sea.

According to another aspect of the invention the device is used as a loading unit in coastal regions of the sea without quay installations, or for stationing of vessels comprising installations for the production of electric power.

A dock (an ocean dock, designed for operation on the open sea) is another term which is synonymous with the expression float construction. In what follows the term float construction is chosen to be used.

By the invention the project is thus made economically attractive in that the construction can be built at conventional workshops based on the use of known building techniques. Furthermore the float construction can be designed so that the bulk of the mooring forces are received by the dock and are not transferred to the vessel, something which will simplify the design of the vessel itself, which is advantageous as to cost, and improves the possibility for rebuilding used tankers for oil/gas production without extensive rebuilding costs. Beyond this the dock can be adapted to the vessel so that simple fastening arrangements can be employed between the float construction and the vessel, where these can be separately connected or disconnected.

The coupling up and connecting points between vessel and float are situated above water and are readily accessible to inspection, repairs etc.. When the float construction floats alone the stresses it is exposed to from the environmental forces, are substantially less, compared with a permanently moored vessel.

During operation of the production vessel/float construction it is regarded as an advantage, inter alia strengthwise and operationally, that this coupled together system behaves as to movement as one body in the sea. By the invention the vessel can consequently be fastened in or coupled to a floating float construction, where the float construction is moored to the sea bottom with a number of mooring lines, and that the vessel during operation is coupled to production systems for oil and gas, herein for

example supply pipes and if necessary export pipes for oil and gas. Further the associated systems coupled together, can be separated so that the vessel can be removed from the floating, anchored float construction. The float
5 construction after the separation will normally remain anchored, while the vessel can be towed away or proceed on its own engine power.

Coupling occurs in an opposite sequence in that the vessel first enters the float construction and is fastened
10 to this, for example mechanically or by means of mooring lines, and thereafter the necessary production systems having pipes and cables are coupled up to the production vessel, preferably above water.

The especially preferred constructions of the device
15 according to the invention are described in the dependent claims.

The vessel and the float construction according to the invention are used for offshore production of oil and gas so that the established, strong requirements for safety on
20 board are taken care of, and that the vessel/float construction is in operation the bulk of the year, but has the possibility of uncoupling during the rare, but totally extreme weather conditions which for example when the direction of a 100 year storm turns beyond the rotation
25 capacity of the vessel/float construction or one chooses systematically to disconnect early, based on a warning about extreme weather conditions.

This is achieved according to a construction of the invention in that a production vessel adapted to the design
30 of a floating, anchored float construction is fastened into the float construction, so that the vessel and the float construction behave as regards movement almost or completely as one body, and that a number of pipe lines import or export oil/gas to/from the vessel, either
35 directly to the vessel or via the float construction. Oil/gas are transported for example from underwater wells or from other installations. Due to the vessel being able to take the weather from both ends the need is reduced for

rotation towards the weather to about +/- 90°, something which in turn opens to tremendously simple and cost-effective solutions for anchoring and pulling-in systems of production risers. The use of the turret, swivels, cable drums or the like for the production pipes becomes either
5 totally redundant or can be replaced by for example simple hose-based transfer systems, and traditional flange connections.

It is an advantage that the anchor lines are fastened
10 to turnable line leads (eng: fair leads), pulleys, or the like, where for example the line lead rotates around its own axis of rotation. An anchoring " turret " built into the float construction can be employed as an anchoring fastening, but the preferred solution is that the anchoring
15 lines are fastened to the float construction itself. With anchoring amidships, the vessel/dock will be dependent upon the propulsion installation which acts sideways for maintaining the direction towards the weather. Alternatively suitable support anchoring lines can be used
20 for orienting the direction of the vessel, in addition to the conventional anchoring. It is considered as advantageous that a possible propulsion installation is placed on the vessel, while possible support anchoring lines for turning the vessel according to the weather can
25 be placed either on the vessel or on the float construction. Various anchoring systems are relevant for use in connection with the invention, such as chains, wires, synthetics, etc.. The design of the anchoring system will be dependent upon the size of the vessel and the float
30 construction, the local environmental conditions, water depth, design requirements, etc., but typically one can look for the use of 6 - 12 anchor lines.

Since the vessel and the float construction is to be able at times to be disconnected, and the float
35 construction is to be able to lie alone back at the area in an anchored condition, it is regarded as a clear advantage that the most possible of the anchoring lines, preferably all lines, are fastened to the float construction, and thus

the fewest possible, preferably none, of the anchoring lines are fastened to the vessel, during operation.

By choice of anchoring system and placement of winches and line leads it is possible to determine the axis of
5 rotation of the production vessel/float construction. It is regarded as advantageous that the distance from the axis of rotation of the vessel/float construction to the pulling in region of the risers does not become too long, since the pulling in region will move in an arc of about $\pm 90^\circ$
10 around the axis of rotation.

The float construction can be structurally designed in a series of ways, depending upon environmental conditions, size of production vessel, etc., for example as a pure sheet-strut hull, by welding together pipe-formed floating
15 bodies in the form of pontoons and columns, or the like. Structurally the same principles can be employed as for a semi-sub, in the form of pontoons and columns. In individual ocean environments this is very advantageous, in that the force of the waves on the float construction
20 during extreme weather conditions, when the float construction lies moored alone, is substantially reduced compared with the coupled unit of vessel and float construction. The shape of the float construction can vary as required. In the design of the float construction (the
25 dock) it is therefore particularly desirable to give weight to reducing the effect of the environmental forces which act on the float construction, both when it is coupled to the vessel and when the float construction lies anchored alone, with the vessel disconnected. An especially
30 preferred design will be to give the float construction a U-shape with the bottom of the U-shape below water, wherein the production vessel can be floated in between the two sidewalls of the dock. These two sidewalls can be differently designed, depending on equipment, anchoring,
35 pulling in of risers, etc..

The float construction preferably has a length which is $1/2-1/5$ of the length of the vessel, especially preferred $1/4-1/5$. In Figures 6 and 7 there is shown a

larger edition where the ratio is about 1/2, and in this case the float construction can be employed for example for the storage of fluids.

Other forms of interest will be for example that the float comprises a sidewall, that is to say that the float construction is an approximate barge, a semi-submersible construction, or the like, where the production vessel is coupled or fastened to the outer side of the float construction, closest as to a quay. The coupling of the production vessel to the float construction which occurs by the use of various devices and methods well-known per se , if desired in a combination between them, such as mechanical locking, mooring, lifting of the dock until contact with the vessel by means of deballasting or if desired winch arrangements, use of hydraulic locking systems, or the like.

Various types of equipment in addition to the anchoring systems, can also be mounted on board the float constructions, for example pulling in systems for production risers if it is desirable to draw the risers up to the dock instead of up into the vessel.

The float construction can also be equipped with installations for drilling or well interventions, either complete installations corresponding to those one finds on survey rigs or parts of such an installation where the remainder of the systems, such as electric power generation, mud treatment, or the like is placed on board the vessel. It is regarded as an advantage that the axis of rotation for the production vessel/float construction is approximately the same as the axis of rotation of the prospective drill stem, drilling taking place either from the vessel or from the dock.

The float construction can also be equipped and designed for the storage of oil if this is desirable. In this case it can be advantageous to install unloading equipment on board the float construction.

It can be advantageous in some connections that the float construction is not permanently manned in the form of

accommodation quarters, offices, or the like, because it can be cost-effective that the float construction and necessary equipment on board are designed with a view to large sea gushes and timely submerging in the worst storms.

5 This is possible with the known technology, and it is important that the float construction can rapidly resume the operations when the weather has improved and coupling together with the production vessel is carried out.

10 The production vessel/float construction according to the invention can be explained further in the following description having regard to the accompanying Figures, wherein:

Fig. 1 shows a side section of the anchored production vessel/float construction.

15 Figure 2 shows a cross-section of a small other variant of the same.

Figures 3 and 4 show alternative designs of the anchored production vessel/float construction.

20 Figure 5 shows a plane section of the production vessel/float construction and shows possible rotation around an axis.

Figure 6 shows a perspective sketch of the vessel/float construction.

25 Figure 7 shows a perspective sketch of the float construction per se according to the invention.

Figure 8 shows a perspective sketch of the solution where the vessel is arranged with a distance between the keel of the vessel and the floor of the float construction.

30 Like parts of the drawn details are given the same reference numerals on the dissimilar Figures. By way of introduction Figures 1, 2 and 5 are referred to which illustrate the floating float construction 2 with the production vessel 1 which is fastened in or moored to the float construction 2 by means of locking arrangement 13.
35 Reference is also made to Figure 7 which shows the float construction per se. The locking arrangement 13 can be mechanical, mooring with ropes, hydraulic locking or the like, but will be arranged so that the vessel and the float

construction can both be easily and safely disconnected and connected. The level of the float construction 2 in the sea can if desired be raised or lowered by ballasting, or by means of hoisting arrangements on the vessel. That is to say that when the vessel is led into the U shape of the float, then the vessel can either be lowered down until frictional contact is obtained with the float, or that the float is hoisted up.

The float construction 2 is anchored to sea bottoms by means of the anchor lines 3. The number of anchor lines 3 and placement thereof will be dependent on the environmental forces and size of the construction. The anchoring will be conventional and be based on chains, wires, synthetic materials, etc.. If tightening in of the lines 3 is desirable during the operations this is done for example with anchor winches 10.

The pulling in of the production risers 4,4' can be done either up to the production vessel 1 directly or preferably to the float construction 2.

The production risers 4,4' can either come from the well plate 11 (the well head) beneath the vessel or from other more remotely disposed locations on the sea bottom. If the production risers 4' are led up into the vessel it will be natural that this occurs through a vessel well 9. If these pipes 4 are led up into the float construction 2 a corresponding solution will be to lead them up through the well 8 which the float construction (ocean dock) is designed with.

The production vessel will with advantage be designed to be able to be positioned with both ends towards the weather, but not necessarily having a symmetric design.

The unit of the production vessel/float construction is then rotated according to Figure 5 around an angle sector V of about $\pm 90^\circ$, but generally up to about $110-115^\circ$. In milder ocean regions the need for rotation of the whole construction can be less, for example $\pm 60^\circ$.

The unit which consists of the float construction 2 and the vessel 1 will be able to be fitted out with

drilling installation 5. The drilling installation 5 can either be placed on the vessel 1, something which is a preferred solution, and illustrated in Figures 1, 2, 5 and 6 or on the float construction 2 as exemplified in Figures 3 and 4. It is an advantage that anchoring of the float construction/production vessel 1,2 is arranged so that the axis of rotation is around the drilling axis as shown in Figure 5 and which thus to a large degree coincides with the drill stem 6.

10 As is evident from Figure 7 the float construction preferably comprises a U-shaped ballastable dock 2 formed by two vertical sidewall sections 14,16 mutually connected by a bottom section 18. The anchor lines which connect the float section to the sea bottom are shown by 3. A conduit 4
15 leads produced hydrocarbon upwards to the section for further transport to the vessel. If desired the conduit, shown as an alternative by 4', can be led upwards in a well 20 in the bottom 18 of the section and further directly into a vessel (not shown in Figure 7). The anchor winches,
20 shown at 10 can be employed to position and rotate the unit of vessel and float section horizontally. Both the vessel and the float can comprise hollow space for ballasting with water, plus that locking means on the vessel can cooperate with fixing means on a float construction which it is
25 positioned on, or vice-versa. A vessel can thereby be placed between the two sidewalls and achieve physical contact with the bottom section of the float construction (the dock) when the float is raised, for example by pumping out water from the hollow spaces, or that the ship is
30 lowered, so that frictional contact is achieved between dock and vessel.

In order to maintain a desired vertical contact pressure between the vessel and the bottom section of the float construction, the unit can be equipped with measuring
35 equipment, for example pressure cells between the bottom of the vessel and the float. The pressure cells can register the contact pressure between the constructions and the signals therefrom are led to a computer installation which

is programmed to control the driving of the ballast systems for raising/lowering of the vessel or float. This for example can be of interest when the vessel is filled with oil for storage. Then this instrumentation is employed to effect a controlled ballasting of the unit, so that undesired harmful and degrading forces are avoided both in the hull of the vessel and in the float construction.

According to a preferred construction of the invention it can be desirable in individual cases that the keel of the vessel does not rest directly against the floor /bottom section 22 of the float construction. That is to say that there is established a distance A between the keel of the vessel and "the floor" 22 of the float construction. This can be important for the instances where the construction of the vessel can be involved in damage (structural changes, cracks and the like) if it is exposed to substantial movements relative to the underlying float construction. This applies especially to the vertical movements which float/vessel are exposed to. In such a case the vessel can be placed within the float construction so that there is a given distance (such as some metres) between the keel and the floor/top surface of the float construction. This is illustrated schematically in Figure 8, (based on Figure 2) where said distance is marked with the designation A.

In these cases it is an advantage that there are arranged on each side at least two locking arrangements and 13' (the one arranged below the water line), having a vertical mutual distance. These locking arrangements can comprise mechanical locking means, such as hydraulically outwardly displaceable pistons and the like, mooring systems with ropes, hydraulic locking or the like, and are arranged so that the vessel and the float construction can both be easily and safely disconnected and connected. Thereby there is obtained sideways and axial support relative to the float construction. Thereby the vessel can move, such as roll, in step with the float construction without the keel striking the floor of the float

construction. The ballast system of the float construction is designed so that it can establish a given distance between the keel of the vessel and the floor of the float construction.

P A T E N T C L A I M S

1. Device for positioning of vessels, such as ships,
5 barge, semi-sub or the like, relative to the effecting of
an activity from the vessel, such as drilling, production
or geological investigations and the like, in connection
with the recovery or transport of hydrocarbons at sea,
characterised in that

10 the device comprises a floating float construction
whose vertical position in the sea can be regulated, and is
anchored to the sea bottom via a number of anchoring lines,
and if desired can be turned in a horizontal plane,

15 that the vessel is adapted for positioning adjacent to
the float construction, and

that the float construction comprises means for
detachably fixing the vessel to the float construction, so
that the units move as one unit.

20 2. Device in accordance with claim 1, characterised in
that the vertical position of the float construction in the
sea can be regulated by ballasting, that is to say the
leading in and out of water to/from hollow spaces in the
construction, or by hoisting arrangements on board the
25 vessel.

3. Device in accordance with claims 1 and 2,
characterised in that the float construction comprises a U-
shaped ballastable dock formed by two vertical sidewalls
30 mutually connected to a bottom section, and the vessel is
adapted to be placed between the two sidewalls and have
physical contact with the bottom section when the dock is
raised or the vessel is lowered, so that frictional contact
is achieved between the units.

35

4. Device in accordance with one of the preceding claims,
characterised by the fixing means for detachable fastening
comprising mechanical, hydraulic or wedge operating locking
means, or mooring systems with hawsers, cables, wires,
5 chains or the like.

5. Device in accordance with one of the preceding claims,
characterised in that the float construction comprises a
raisable and lowerable barge construction to which the
10 vessel can be fixed approximately as to a quay.

6. Device in accordance with one of the preceding claims,
characterised in that the float construction comprises
devices for the support of production risers, and if
15 desired pipes for the transport of fluids, which lead
upwardly from the sea bottom, and for further detachable
coupling of said pipes to a production vessel fixed to the
float construction which comprises a storage and/or
treatment installation for hydrocarbons.

20 7. Device in accordance with one of the preceding claims,
characterised in that the float construction comprises
devices for carrying out drilling operations in the sea
bottom.

25 8. Devices in accordance with one of the preceding
claims, characterised in that the float construction
comprises devices both for carrying out of drilling
operations in the sea bottom and for the production of
30 hydrocarbons.

9. Device in accordance with one of the preceding claims,
characterised in that a production installation and/or
drilling installation is/are arranged connected to the
35 vessel per se.

10. Device in accordance with one of the preceding claims,
characterised in that by regulating the line tension, the
unit of the vessel and the dock construction is adapted to
be turned towards the direction of the weather and an angle
5 sector of about $\pm 90^\circ$ by means of a propulsion
installation and/or anchoring lines.

11. Device in accordance with claim 10, characterised in
that the vessel is anchored to the sea bottom via a number
10 of anchoring lines.

12. Device in accordance with one of the preceding claims,
characterised in that the float construction has a length
which is about $1/2-1/5$ of the length of the vessel,
15 especially preferred a length which is about $1/4-1/5$ of the
length of the vessel.

13. Device in accordance with one of the preceding claims,
characterised in that there is arranged measuring
20 equipment, such as pressure cells, for connecting to the
vessel and/or float construction, for registering the
contact pressure, preferably the vertical contact pressure,
between the vessel and the bottom section of the float
construction.

25 14. Device in accordance with one of the preceding claims,
characterised in that there is a given distance (A) between
the keel of the vessel and the floor/top surface (22) of
the float construction.

30 15. The use of the device according to the preceding
claims, as a loading unit in coastal sea regions without
quay installations, or for the stationing of vessels
comprising installations for the production of electric
35 power.

1/5

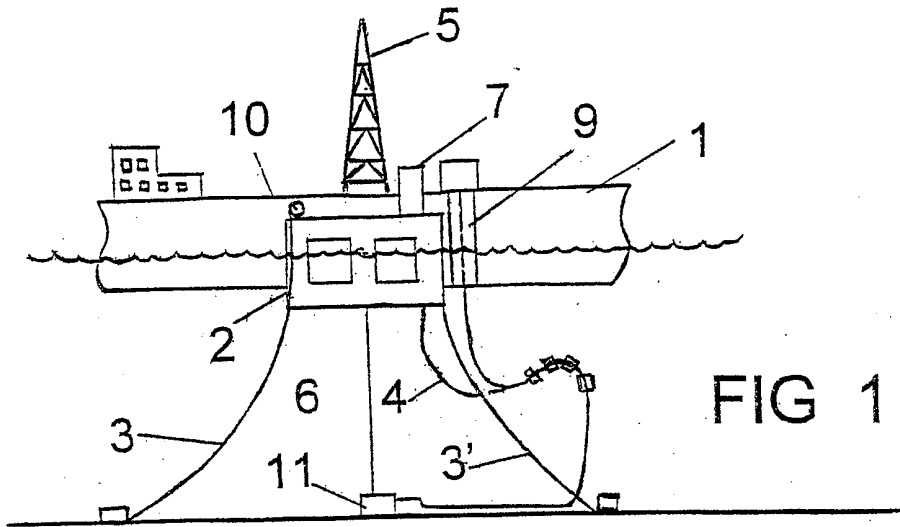

FIG 1

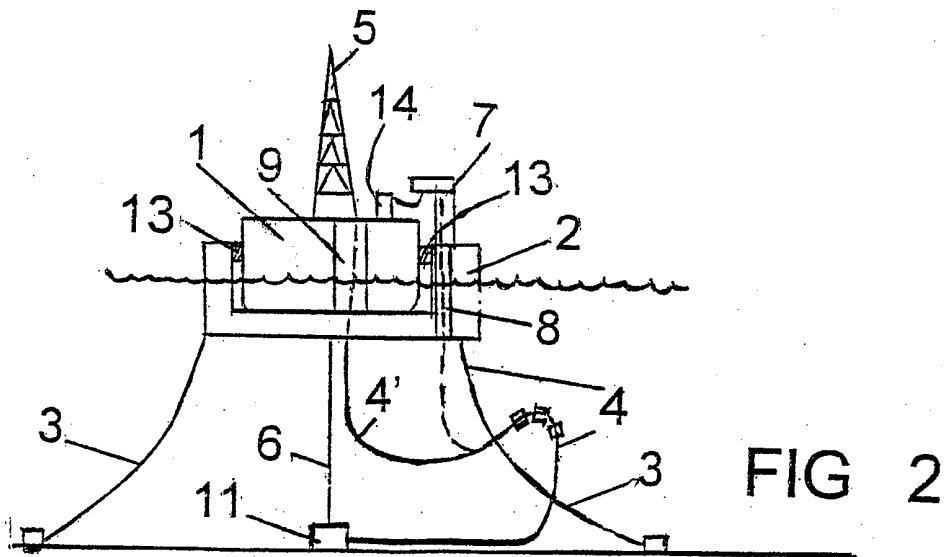

FIG 2

2/5

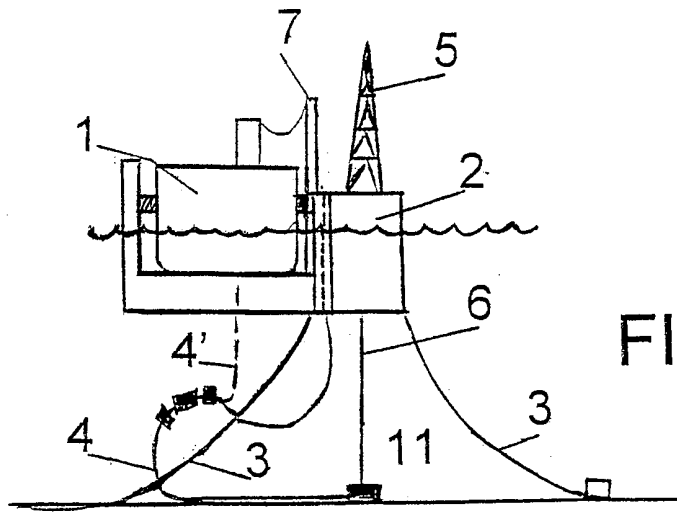

FIG 3

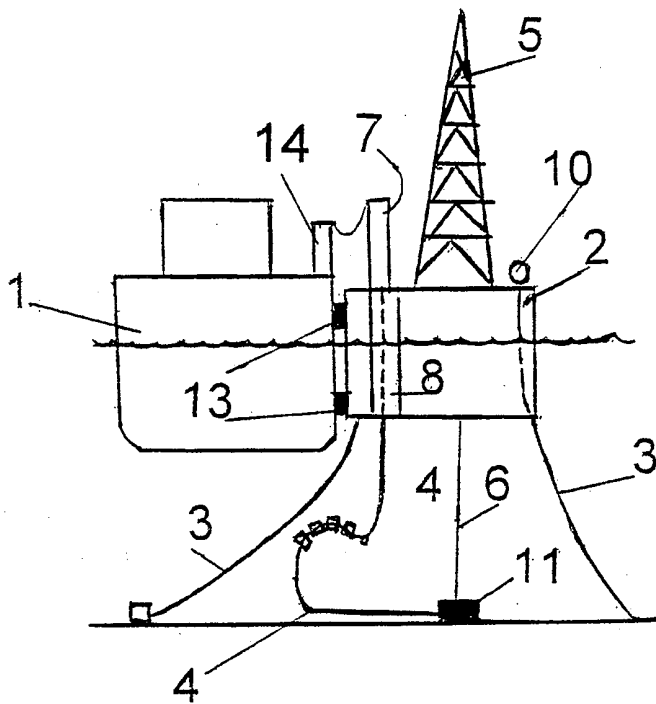

FIG 4

3/5

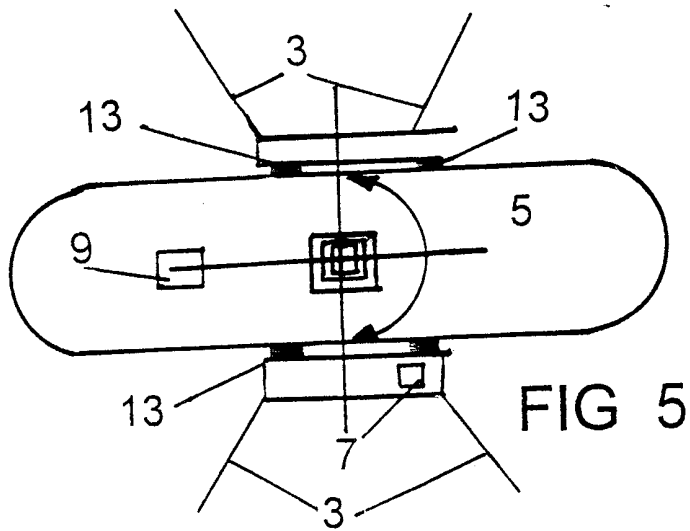

FIG 5

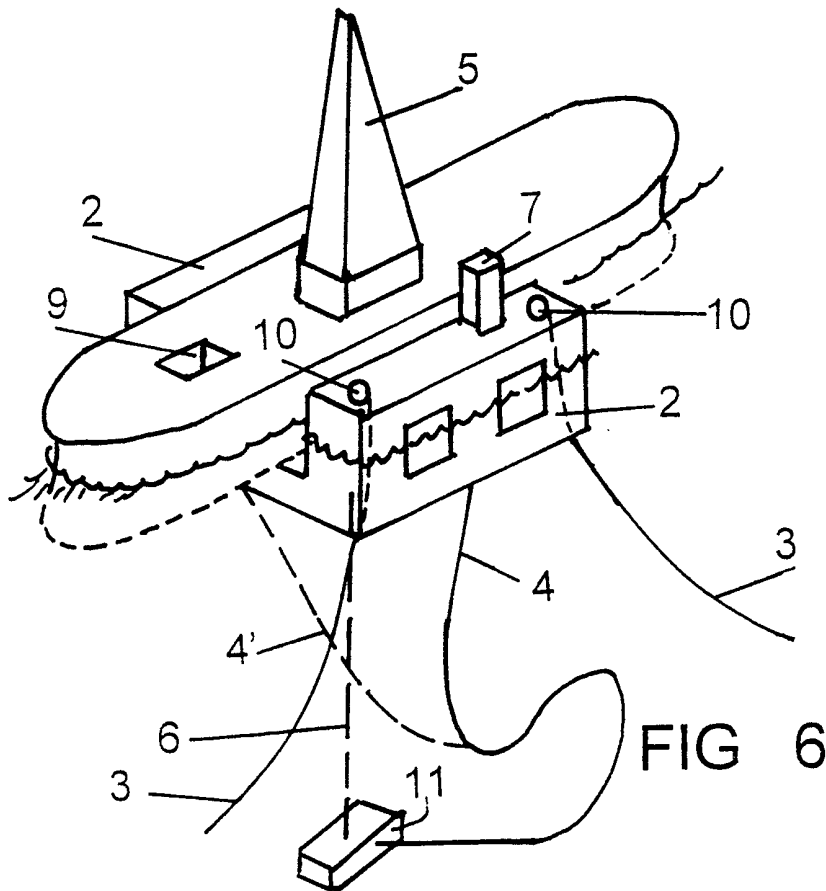
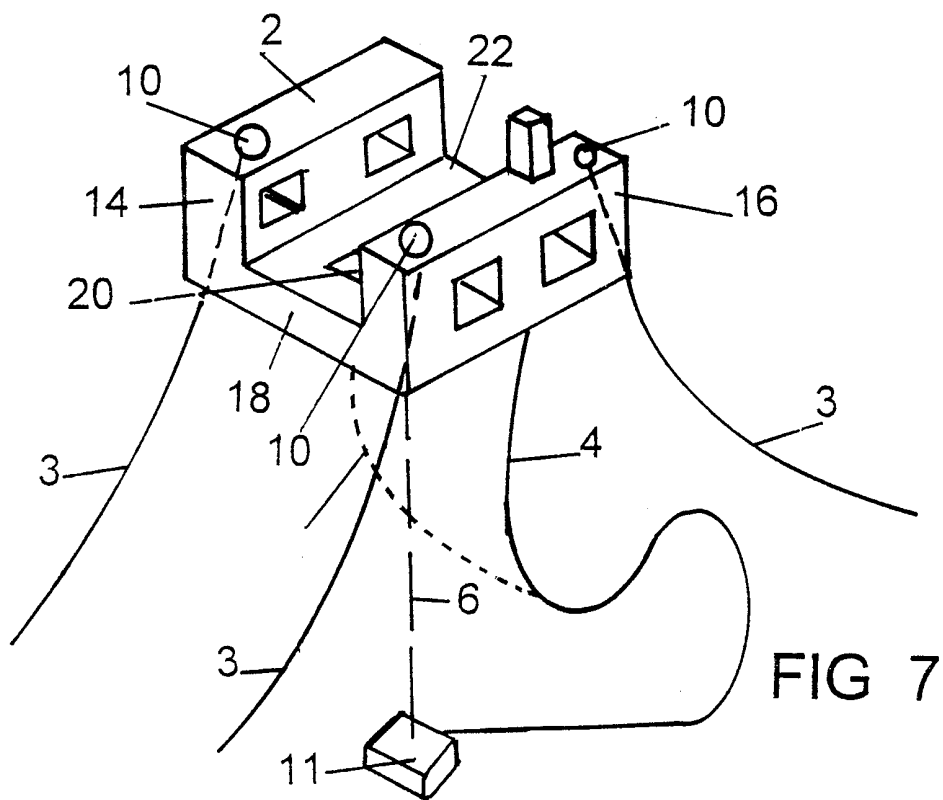

FIG 6

4/5



5/5

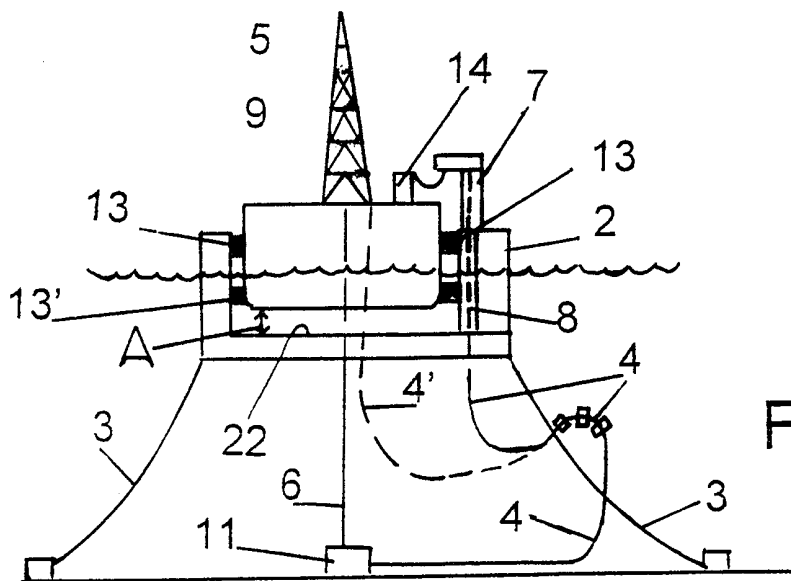

FIG 8

INTERNATIONAL SEARCH REPORT

International application No.

PCT/NO 99/00327

A. CLASSIFICATION OF SUBJECT MATTER

IPC7: B63B 21/50, B63B 35/44

According to International Patent Classification (IPC) or to both national classification and IPC

B. FIELDS SEARCHED

Minimum documentation searched (classification system followed by classification symbols)

IPC7: B63B, B63C

Documentation searched other than minimum documentation to the extent that such documents are included in the fields searched

SE,DK,FI,NO classes as above

Electronic data base consulted during the international search (name of data base and, where practicable, search terms used)

C. DOCUMENTS CONSIDERED TO BE RELEVANT

Category*	Citation of document, with indication, where appropriate, of the relevant passages	Relevant to claim No.
X	GB 2285773 A (KVAERNER EARL AND WRIGHT), 26 July 1995 (26.07.95), page 2, line 1 - line 10; page 3, line 25 - page 5, line 27, figures 1-4, abstract	1-4,6-9
A	--	13,14
X	GB 2301800 A (KVAERNER EARL AND WRIGHT), 18 December 1996 (18.12.96), page 4, line 1 - page 5, line 21, figures 1,2, abstract	1,2,3,6,7,9, 11
A	--	4,13

Further documents are listed in the continuation of Box C.

See patent family annex.

* Special categories of cited documents:

"A" document defining the general state of the art which is not considered to be of particular relevance

"E" earlier document but published on or after the international filing date

"L" document which may throw doubts on priority claim(s) or which is cited to establish the publication date of another citation or other special reason (as specified)

"O" document referring to an oral disclosure, use, exhibition or other means

"P" document published prior to the international filing date but later than the priority date claimed

"T" later document published after the international filing date or priority date and not in conflict with the application but cited to understand the principle or theory underlying the invention

"X" document of particular relevance: the claimed invention cannot be considered novel or cannot be considered to involve an inventive step when the document is taken alone

"Y" document of particular relevance: the claimed invention cannot be considered to involve an inventive step when the document is combined with one or more other such documents, such combination being obvious to a person skilled in the art

"&" document member of the same patent family

Date of the actual completion of the international search

15 February 2000

Date of mailing of the international search report

18-02-2000

Name and mailing address of the ISA

Swedish Patent Office
Box 5055, S-102 42 STOCKHOLM
Facsimile No. +46 8 666 02 86

Authorized officer

Christer Jönsson
Telephone No. +46 8 782 25 00

INTERNATIONAL SEARCH REPORT

International application No.

PCT/NO 99/00327

C (Continuation). DOCUMENTS CONSIDERED TO BE RELEVANT		
Category*	Citation of document, with indication, where appropriate, of the relevant passages	Relevant to claim No.
X	NO 954500 L (DEN NORSKE STATS OLJESELSKAP AS), 7 May 1997 (07.05.97)	1,4,5,6
A	--	2,7,8,10
A	Patent Abstracts of Japan, abstract of JP 53-142791 A (HITACHI ZOSEN K.K.), 12 December 1978 (12.12.78) -----	1-15

INTERNATIONAL SEARCH REPORT

Information on patent family members

International application No.

PCT/NO 99/00327

Patent document cited in search report	Publication date	Patent family member(s)	Publication date
GB 2285773 A	26/07/95	AU 1592595 A	08/08/95
		AU 6851094 A	20/12/94
		BR 9506538 A	28/10/97
		CN 1143935 A	26/02/97
		GB 9401141 D	16/03/94
		GB 9501141 D	00/00/00
		JP 9509382 T	22/09/97
		NO 962963 A	15/07/96
		US 5791819 A	11/08/98
		US 5821077 A	13/10/98
		WO 9519911 A	27/07/95

GB 2301800 A	18/12/96	AU 5905596 A	30/12/96
		GB 9511541 D	00/00/00
		GB 9611740 D	00/00/00
		WO 9640549 A	19/12/96

NO 954500 L	07/05/97	NONE	
