

Oct. 15, 1935.

I. M. HOWER

2,017,499

SANITARY BELT

Filed Aug. 17, 1934

2 Sheets-Sheet 1

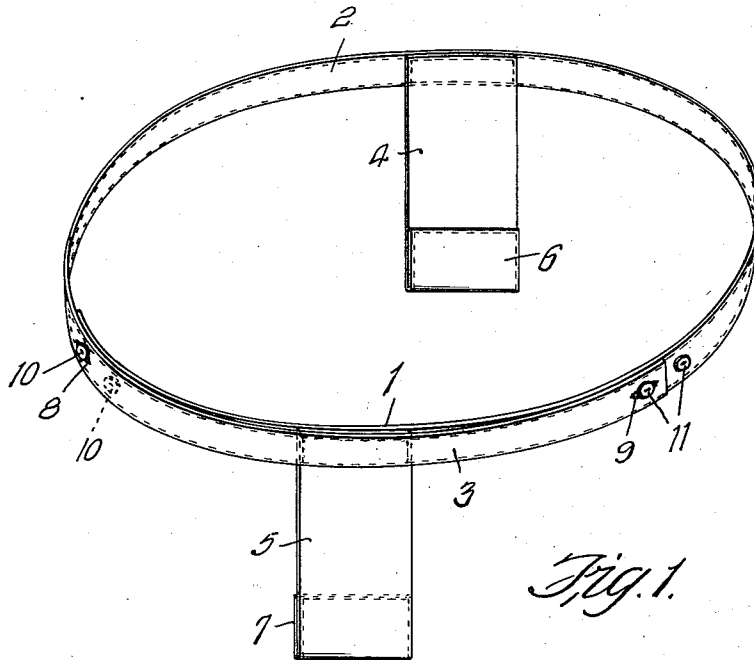

Fig. 1.

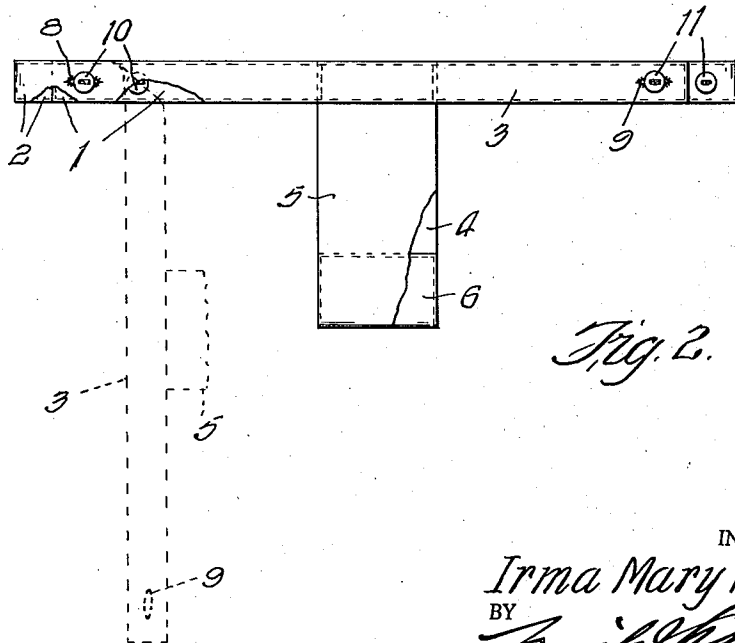

Fig. 2.

INVENTOR:

Irma Mary Hower.

BY

*Frank J. Hower*

ATTORNEY.



# UNITED STATES PATENT OFFICE

2,017,499

## SANITARY BELT

Irma Mary Hower, St. Louis, Mo.

Application August 17, 1934, Serial No. 740,269

2 Claims. (Cl. 128—291)

My invention relates to ladies' sanitary belts, and, more particularly to belts periodically worn by ladies, to which a napkin is attached and suspended from depending parts thereof, and, the invention has for its object the provision of a belt to overcome certain practical objections to, and defects in, the present types of belts now worn periodically by ladies.

An object of my invention is to provide a ladies' belt, which, due to the construction thereof, will not roll into cord like formation when worn, and, which will prove far more satisfactory from the standpoint of comfort than present types of belts.

Another object of the invention is the provision of a belt of the character set forth, wherein the belt is formed of a waist encircling section and on overlapping back section detachably fastened to the waist encircling section at remote points, thereby permitting the overlapping back section to flex or sag downwardly midway the points of fastening to the waist encircling section during forwardly bending movements when the belt is worn for the purpose intended.

A further object of the invention is the provision of means for adjustably fastening the back overlapping section to the waist encircling section to render the waist encircling section larger, or smaller in size, as desired.

Another object of the invention is the provision of a belt wherein the front section thereof is provided with an extension, which after the front and back sections of the belt are fastened together, the extension serves as an overlapping back section when fastened at its free end to the back section of the belt.

A further object of the invention is to provide the overlapping back section with a flexible tab to co-act with a flexible tab on the front section of the belt and from which tabs a napkin is adapted to be suspended.

Another object of my invention is to provide a belt to be periodically worn by ladies, with an extension adapted to overlap the back section of the belt and with its free end suitably and detachably fastened to the belt and provided with a suitable napkin supporting tab dependent therefrom.

A still further object of the invention is the provision of a belt to be periodically worn by ladies, which possesses advantages in points of simplicity and efficiency, and, at the same time proves itself comparatively inexpensive in cost of manufacture.

With the above and other objects in view, the

invention consists in the novel features of construction, arrangement and combination of parts hereinafter more fully described and finally pointed out in the claims hereto appended.

Referring to the accompanying drawings forming a part of this specification, wherein like characters of reference denote similar parts throughout the several views:

Fig. 1 is a view showing the belting formed into a belt.

Fig. 2 is a side elevation of the belt looking toward the back thereof, and showing the extension, or overlapping back section in dotted lines, as detached at its free end from the fastening device which holds it in position to the rear of the back section of the belt proper.

Fig. 3 is an outside elevation of the belting straightened out.

Fig. 4 is a modified form of the belt.

In carrying out my present invention, I employ a strip of suitable belting designated generally as A, which is greater in length than to merely girdle the body of a person in the form of a belt proper, so that there will remain an extension to overlap the back section of the belt proper with its free end suitably and detachably fastened to the back section of the belt.

The belting A is figuratively divided into a back belt section 1, a front belt section 2 and an extension or overlapping back strap section 3 directed from one end of the front belt section 1.

A pair of suitable flexible fabric napkin supporting tabs 4 and 5 are suitably secured to and depend from the front belt section 2 and from the extension or overlapping back section 3. From the tabs 4 and 5, when the belt is periodically worn by ladies, a suitable catamenial napkin, or equivalent sanitary article is adapted to be fastened to and suspended from the tabs in the usual, or in any other suitable manner. The sanitary napkin is not shown, as it is not believed necessary to do so, as various types of napkins are made for use with the various types of belts used periodically by women, as well as fastening means for connecting the ends of the napkin to the tabs.

The front depending napkin supporting tab 4 is located approximately midway the distance between the ends of the belting A. Tab 4 may be made from any suitable flexible fabric material with the lower end portion thereof folded back upon the flexible fabric material as at 6, to reinforce the lower ends of the tab.

The back depending napkin supporting tab is

located a suitable, but short distance from the free end of the overlapping back section 3. Tab 5 may be made from any flexible fabric material with the lower end portion thereof folded back upon the flexible fabric material, as at 7, to reinforce the lower end of the tab.

The belting, when worn as a belt, is detachably connected to girdle the body, by suitable fastening devices, and in one embodiment thereof, I have shown a button hole 8 formed in the overlapping back section 3 intermediate the tabs 4 and 5. A second button hole 9 is formed in the overlapping back section 3 intermediate the free end thereof and the back tab 5.

A plurality of spaced buttons 10 are secured to the outer face of the back belt section 1 near the free end thereof for selective engagement with the button hole 8. When the belting is so connected, a waist encircling member or belt proper is formed. A plurality of suitably spaced buttons 11 are secured to the outer face of the band intermediate the aforesaid buttons 10 and the front pad 4 for selective engagement with the button hole 9. This arrangement of buttons and button holes permit the adjustment of the belt as to size, however, if a single button in either instance, is desired, for each button hole, adjustment of the belt, as to size, is not possible, but the belt can be so constructed, if desired. Other fastening devices such for instance as snap fasteners, buckles, and the like may be employed in lieu of the buttons and button holes herein described.

When the belting A is formed into a waist encircling member to girdle a person who is to wear the same, it will be apparent that the belt proper is formed by the front and back sections 2 and 1, respectively, and is adjusted to size by causing a selected button so to engage button hole 8. After this has been done, the belt extension 3 is fastened by the fastening means 9 and 11 so as to overlap the back belt section 2, thereby providing two back belt sections, the inner section 1 of which acts as a belt section only, and the extension, or overlapping back section 3 serving primarily to support the tab 5 to which one end of a sanitary napkin is suitably attached. As the extension, or overlapping back section 3 is not relied upon to serve as a belt section proper, it is apparent that it will sag or flex downwardly midway the points of fastening it to back belt section 1 and aid in preventing binding of the napkin during bending movements especially forward bending movements of the body, whether non-elastic, or elastic tabs 5 are employed, as the extension is flexible to a degree relative to the back section 1 of the belt. The free end of the extension 3 being, detachably connected to the back belt section 1, by fastening means, permits the free end of the extension to be detached from the back section 1 for toilet purposes, without having to loosen or disturb the belt proper, or the napkin.

The belting A is illustrated in Fig. 3 as made from suitable flexible fabric material. However, it may be made from suitable elastic material, if so desired, or it may be made from fabric material with two elastic inserts A', as illustrated in the modification shown in Fig. 4.

The tabs 4 and 5 are illustrated in Fig. 3 as made from suitable flexible fabric material. However, they may be made from suitable elastic material 4' and 5', respectively, as illustrated in the modification shown in Fig. 4. In this instance, the lower ends of the tabs are made from suitable fabric material and designated 6' and 7'.

It is apparent, however, that elastic tabs may 15 be used with belting having no elastic inserts, belting having elastic inserts, and with all elastic belting, as desired.

The many advantages of the herein described invention will readily suggest themselves to those 20 skilled in the art to which it appertains.

From the foregoing description, it is evident that a simple device for this purpose has been disclosed, but it is to be understood that I do not desire to restrict, or limit myself to the very details of the construction shown and described, which is merely illustrative, it being obvious that changes, not involving the exercise of invention, may be made without conflicting or departing from the spirit of the invention within the scope 30 of the appended claims.

What I claim is:

1. In a sanitary belt construction, a one piece strap formed of flexible cloth material, there being a tab sewed to and depending midway the ends 35 of the strap, there being two pairs of spaced apart buttons sewed to one face of the strap on one side of said tab, there being a second tab sewed to and depending from said strap a short distance from the end of the strap opposite the end to which 40 the buttons are sewed, and there being a pair of button holes formed in the strap, one on each side of the second mentioned tab.

2. A sanitary belt having, in combination, a one piece flexible body encircling member, a plurality 45 of buttons secured to the flexible member and the member having a pair of button holes formed therein to engage selected buttons to adjust and fasten the belt to size with one end portion of the belt overlapping the other end portion and to the 50 outside thereof, said overlapping end portions of the belt occupying approximately one half the circumference of the belt with their points of attachment being approximately opposite each other on opposite sides of the body of the wearer 55 of the belt and disposed to the rear of the body of the wearer, there being a tab secured to and depending from the belt approximately midway the ends thereof, and there being a second tab secured to and depending from the outside overlapping 60 end portion of the belt.

IRMA MARY HOWER.