

(No Model.)

N. PARKS.
ELECTRIC TELEPHONE.

No. 385,956.

Patented July 10, 1888.

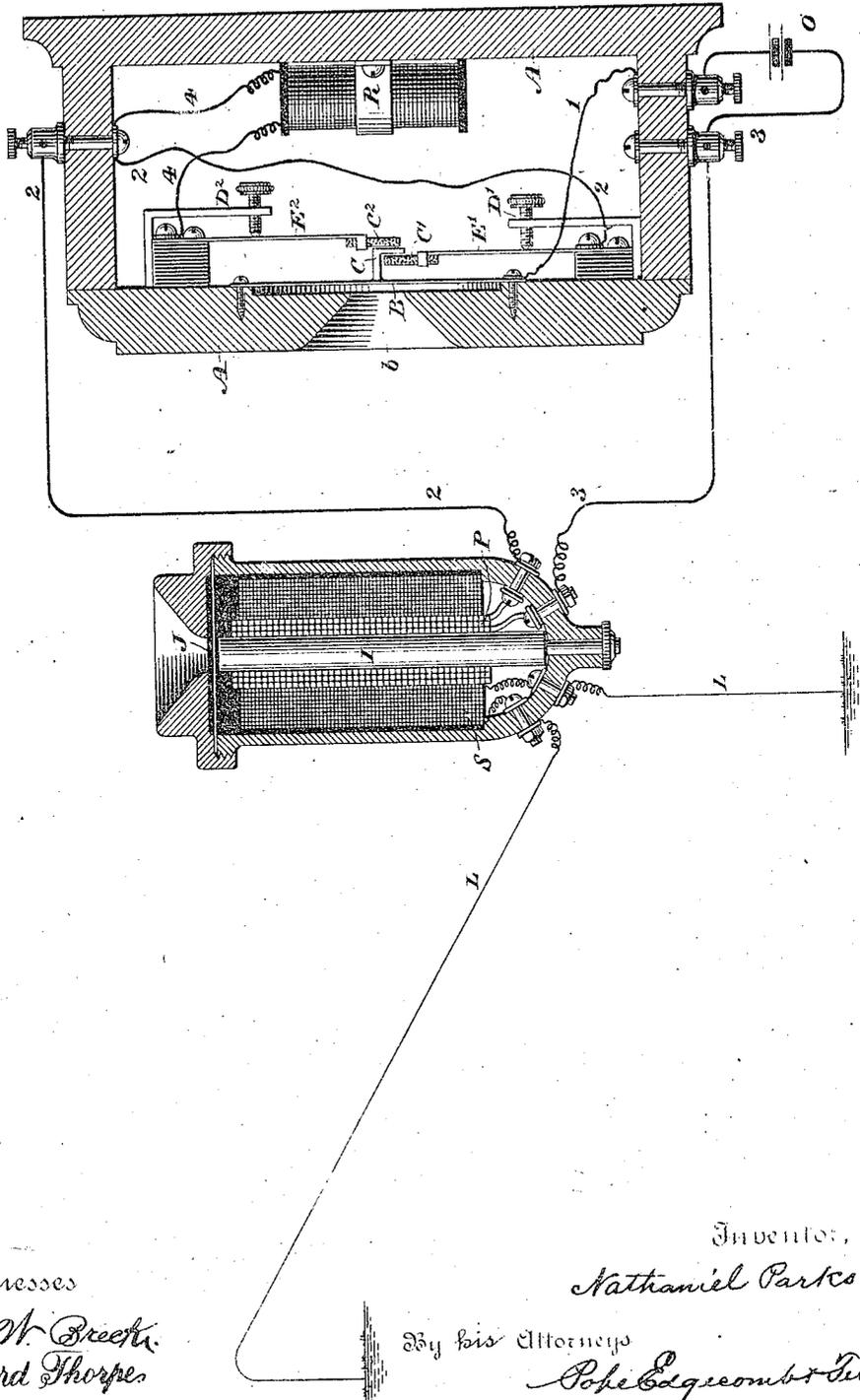

Witnesses
Geo. W. Breech
Edward Thorpe

Inventor,
Nathaniel Parks.

By his Attorneys

Pope Edgcomb & Tamm

UNITED STATES PATENT OFFICE.

NATHANIEL PARKS, OF DEANSVILLE, NEW YORK.

ELECTRIC TELEPHONE.

SPECIFICATION forming part of Letters Patent No. 385,956, dated July 10, 1888.

Application filed April 20, 1888. Serial No. 271,281. (No model.)

To all whom it may concern:

Be it known that I, NATHANIEL PARKS, a citizen of the United States, residing in Deansville, in the county of Oneida, in the State of New York, have invented certain new and useful Improvements in Electric Telephones, of which the following is a specification.

The invention relates to the class of electrical apparatus employed for transmitting and receiving vocal sounds.

The object of the invention is to provide instruments which will cause the required variation in the strength of an electric current under the influence of sound-waves or air-vibrations, whether of great or small amplitude, and which will convert such variations or electrical undulations into vibrations corresponding to the original sound-waves with as little loss of energy as possible.

Heretofore it has been customary to occasion the undulations in the electric current by causing it to traverse an artificial resistance, the value of which is increased and diminished by and in accordance with the sound-waves. To accomplish this two electrodes are connected in the circuit and held against each other in such manner that their pressure and consequent resistance may be varied through the instrumentality of the sound-waves. When the sound-waves are very light, the variation in the pressure is correspondingly small, and when the waves are caused by sounds which are too loud the electrodes are thrown apart and a consequent mutilation of the electric undulation is caused, since the flow of the current is momentarily interrupted. The present invention aims to remove this defect and provide an instrument which will operate perfectly whether the sound-waves be light or heavy.

In general terms, the invention may be stated to consist in mounting upon a diaphragm or other body responding to the sound-waves an electrode which extends in a direction at right angles to its direction of movement and passes between two other electrodes, one of which is connected directly with the source of electricity, while the other is connected with the same source through an artificial resistance. The central electrode is connected with the other pole of the source. The movements of the diaphragm in one direction lessen the

pressure of the central electrode upon one of the outer electrodes and increase its pressure upon the other, and the movements of the diaphragm in the opposite direction reverse these effects. As the pressure is thus changed by the vibrations of the diaphragm, the resistance offered by the two branch circuits will be varied, the resistance of one branch being increased as that of the other is diminished. At one limit of its vibration the circuit of the battery will be for the most part or entirely through the branch containing no artificial resistance, and therefore the current will flow freely, since the pressure upon the corresponding electrode will be sufficient to cause very good electrical connection. At the other limit of vibration, however, the resistance of this circuit is increased, or its connections may be entirely interrupted; but the circuit remains through the branch containing the artificial resistance, thus allowing a correspondingly small current to flow.

The receiving-instrument may with advantage be constructed with an inductorium of which the primary coil is included in the circuit of the battery and wound upon a soft-iron core, to which the receiving-diaphragm is applied. The secondary coil leads to the main line. The current through the primary coil will magnetize the core, and thus dispense with the necessity of employing a permanent magnet, and from this construction certain advantages, hereinafter pointed out, may be derived.

The accompanying drawing is a transverse section of the transmitter and the receiver, showing the circuit-connections in diagram.

Referring to the figure, A represents the case of the transmitter. In the front of the case there is formed an opening, *b*, and beneath this there is placed the diaphragm B, which may be of any well-known construction. Upon the diaphragm, preferably at or near its center, there is placed an electrode, C, which is here shown as projecting from the diaphragm at right angles and having its end turned at an angle and passing between two electrodes, C' and C². The central electrode may be of metal and the outer electrodes of carbon, or other suitable materials may be employed. The electrodes C' and C² are mounted upon yielding springs E' and E², and suitable adjust-

ing-screws, D' and D², are applied to the springs, whereby the pressure of the outer electrodes against the central electrode, C, may be regulated. Normally they should be adjusted so as to touch the central electrode lightly when at rest.

The electrode C is electrically connected by a conductor, 1, with one pole of a suitable battery or other source of electricity. (Shown at O.) The electrode C' is connected by a conductor, 2, through the primary coil, P, of an induction-coil. A conductor, 3, leading from this coil, is connected with the remaining pole of the battery. The electrode C² is connected, by a conductor, 4, through a resistance, R, with the conductor 2. The secondary coil S of the inductorium has its respective terminals connected with the main line L L. The two coils are wound upon a core, I, of soft iron, applied to a diaphragm, J, and this device constitutes a receiver.

The operation of the apparatus is as follows: When the instrument is at rest, a current from the battery traverses the conductor 1 to the electrode C, thence through both the electrodes C' and C² and the conductors 2 and 4 to the primary coil of the inductorium, and thence by way of the conductor 3 to the other pole of the battery. The core I thus receives a magnetization, dependent upon the current through the primary coil. Any variations in this current will cause corresponding variations in the magnetism of the core, and will also occasion induced currents in the secondary coil S, and such induced currents will be transmitted upon the line L.

Variations in the primary current are caused in the following manner: When the diaphragm B is moved toward the electrode C', for instance, the electrical contact of the electrodes C and C' becomes more perfect, and a greater amount of current will flow through the coil P. The diminution in the pressure between the electrodes C and C² occurring at the same moment, or even the complete separation of these electrodes, will tend to cause but a slight reduction in the current, since the resistance R is sufficient to prevent much current from flowing through the conductor 4. When the diaphragm is vibrated in the opposite direction, the resistance between the electrodes C and C' becomes greater, and therefore the current is diminished. At the same time the pressure upon the electrodes C² is increased, and the electrodes C and C' may even be separated, and yet the circuit of the battery will remain completed through the conductor 4, but the resistance R will reduce the current flowing to a minimum. It will be evident thus that even if the diaphragm be vibrated by sound-vibrations of sufficient amplitude to throw the electrode C away from the electrode C', yet there will be no mutilation of the speech.

The operation of the receiver will be evident without further description. It may be noted, however, that the induction which occurs between the primary and secondary con-

ductors tends to lessen the magnetism of the core, and also acts upon the primary coil and tends to oppose the battery-current, so that electrical undulations of greater amplitude are occasioned than would be the case were the core a permanent magnet.

I claim as my invention—

1. In a telephonic transmitter, an electrode, two other electrodes applied to opposite sides of the same, means for increasing the pressure of the first-named electrode upon either one of the other electrodes and at the same time diminish the pressure upon the other, branch circuits leading from the two outer electrodes, and an artificial resistance contained in one of the branch conductors.

2. In a telephonic transmitter, an electrode, two contact-electrodes applied to opposite sides of the same, means for increasing the pressure of the first-named electrode upon either of the other electrodes and at the same time diminishing the pressure upon the remaining electrode, branch circuits leading from the two contact-electrodes, an artificial resistance contained in one of the branch conductors, and an inductorium having its primary coil included in the circuit with said branch conductors.

3. A telephonic transmitter, consisting of an electrode, two contact-electrodes applied thereto, means for causing the pressure of the first-named electrode upon the other two to vary inversely, two branch circuits leading from the respective contact electrodes, and an artificial resistance contained in one of the branch circuits.

4. The combination, with a movable diaphragm and an electrode carried or vibrated thereby, of two contact-electrodes applied thereto, the pressure against one electrode being increased as the pressure against the other is diminished, and vice versa, and an electric battery having one pole connected with the first-named electrode and the other pole with the two contact-electrodes, and an artificial resistance interposed between one of the contact-electrodes and said battery.

5. The combination, with a movable diaphragm and an electrode carried or vibrated thereby, of two contact-electrodes applied thereto, the pressure against one electrode being increased as the pressure against the other is diminished, and vice versa, an electric battery having one pole connected with the first-named electrode and the other pole with the two contact-electrodes, and an inductorium having a single primary coil connected in the circuit of said battery and in series with the respective contact-electrodes, substantially as described.

In testimony whereof I have hereunto subscribed my name this 16th day of April, A. D. 1888.

NATHANIEL PARKS.

Witnesses:

B. W. HAMLIN,
FRANK E. LAPHAM.