



(19) **United States**

(12) **Patent Application Publication**

Cornell et al.

(10) **Pub. No.: US 2007/0292278 A1**

(43) **Pub. Date: Dec. 20, 2007**

(54) **AXIAL FLOW PUMP AND MARINE PROPULSION DEVICE**

(76) Inventors: **Donald E. Cornell**, New Port Richey, FL (US); **William M. Farrell**, Walton, NY (US)

Correspondence Address:
Lawrence Harbin
McIntyre Harbin & King
500 Ninth Street SE
Washington, DC 20003 (US)

(21) Appl. No.: **10/591,025**

(22) PCT Filed: **Mar. 15, 2005**

(86) PCT No.: **PCT/US05/08474**

§ 371(c)(1),
(2), (4) Date: **Jul. 3, 2007**

Related U.S. Application Data

(63) Continuation of application No. 10/801,705, filed on Mar. 17, 2004, now Pat. No. 7,108,569.

(60) Provisional application No. 60/455,578, filed on Mar. 19, 2003. Provisional application No. 60/606,905, filed on Sep. 3, 2004.

Publication Classification

(51) **Int. Cl.**
B63H 11/00 (2006.01)
F04B 1/00 (2006.01)
F04B 49/00 (2006.01)

(52) **U.S. Cl.** **417/245; 417/53; 440/38**

(57) **ABSTRACT**

A mechanically reconfigurable marine propulsion device that adapts to engine torque and/or vessel speed thereby providing improved propulsive efficiency and performance. The axial flow propulsion device has two or more stages each having an impeller section and a stator section. Stator vanes and/or the pumping chamber provide a flow diffusion that generates increased hydrostatic pressure from ram pressure recovered from high velocity working fluid which, due to reduced fluid velocity and increased hydrostatic pressure, lowers cavitation events and frictional losses within the propulsion device. Optionally, variable-pitch vanes in the stator section control the amount of ram pressure imparted to the working fluid. Also optionally, variable-pitch inlet guide vanes control the whirl angle and/or mass flow rate of incoming fluid independently of rotor or vessel speed. A set of fixed or variable exit guide vanes aft of the pumping chamber provides flow straightening and pressure maintenance at a discharge nozzle. Other options include a dual flow concentric pumping arrangement that improves performance at low to moderate vessel speeds, an inlet diffuser that recovers ram pressure within an intake duct, and/or a variable area throat in the discharge nozzle that controls the water jet exit velocity according to vessel speed in order to maintain propulsive efficiency. Advantageously, the variable geometry propulsion device enables a shipmaster to achieve improved performance and fuel efficiency over a wide range of vessel speed, vessel loading, sea state conditions, power settings, and/or engine set points in order to achieve higher vessel speeds (e.g., 10 to 30 kts) and/or greater range (e.g., 25-40%) over conventional marine pump jets (i.e., centrifugal or mixed-flow waterjets), which is particularly useful for vessels utilizing 10 to 100 megawatt power plants.

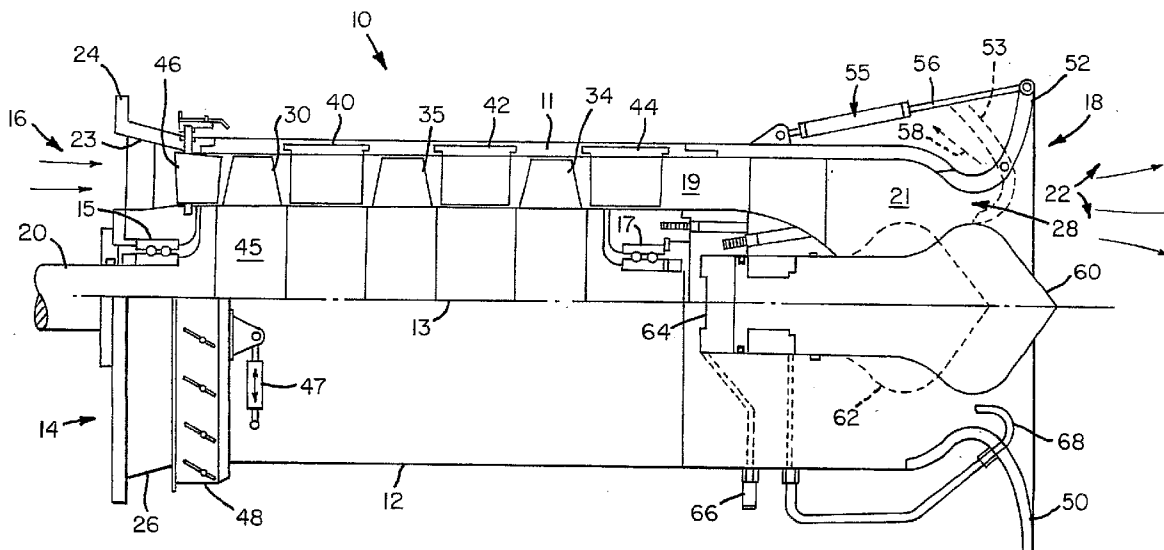

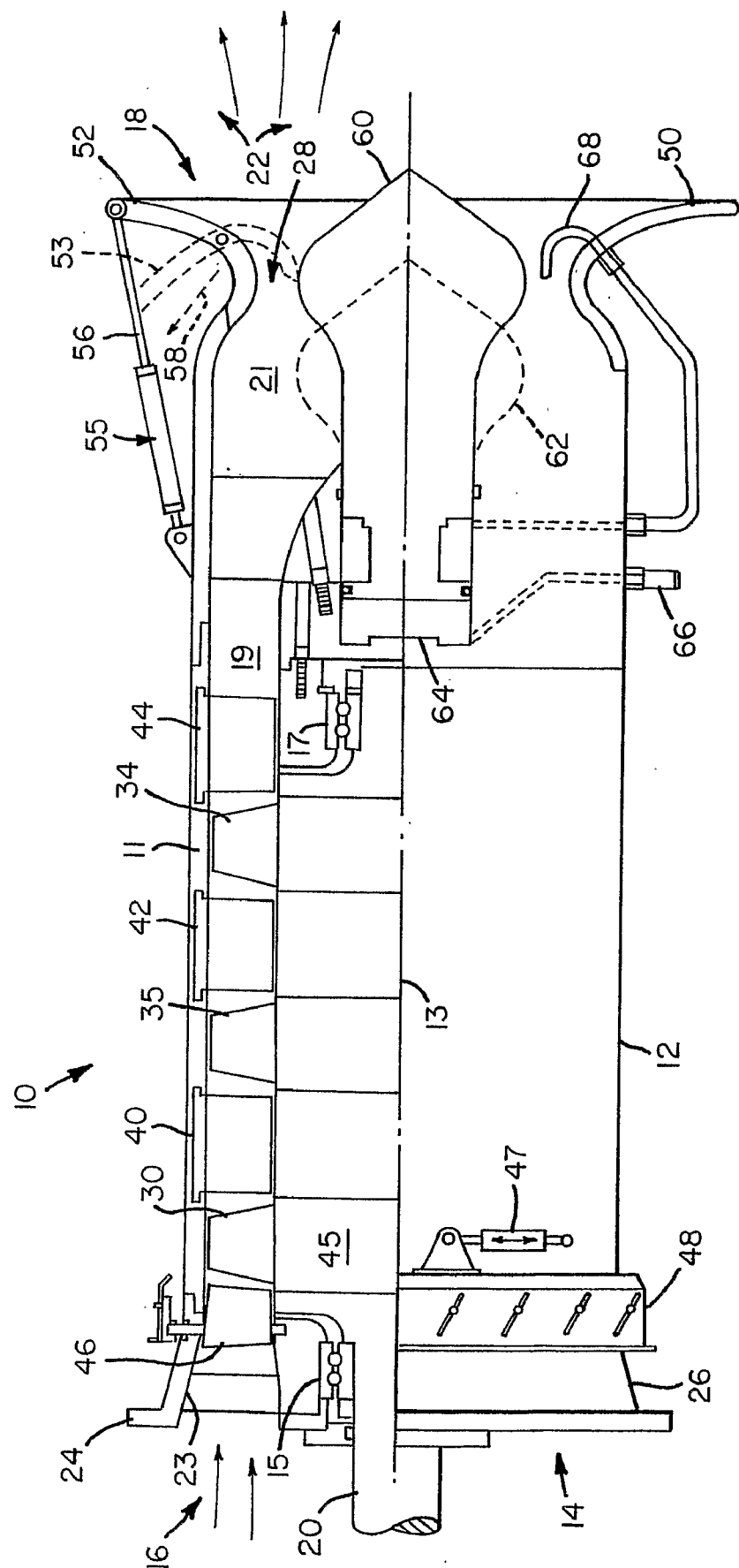

FIG. 1

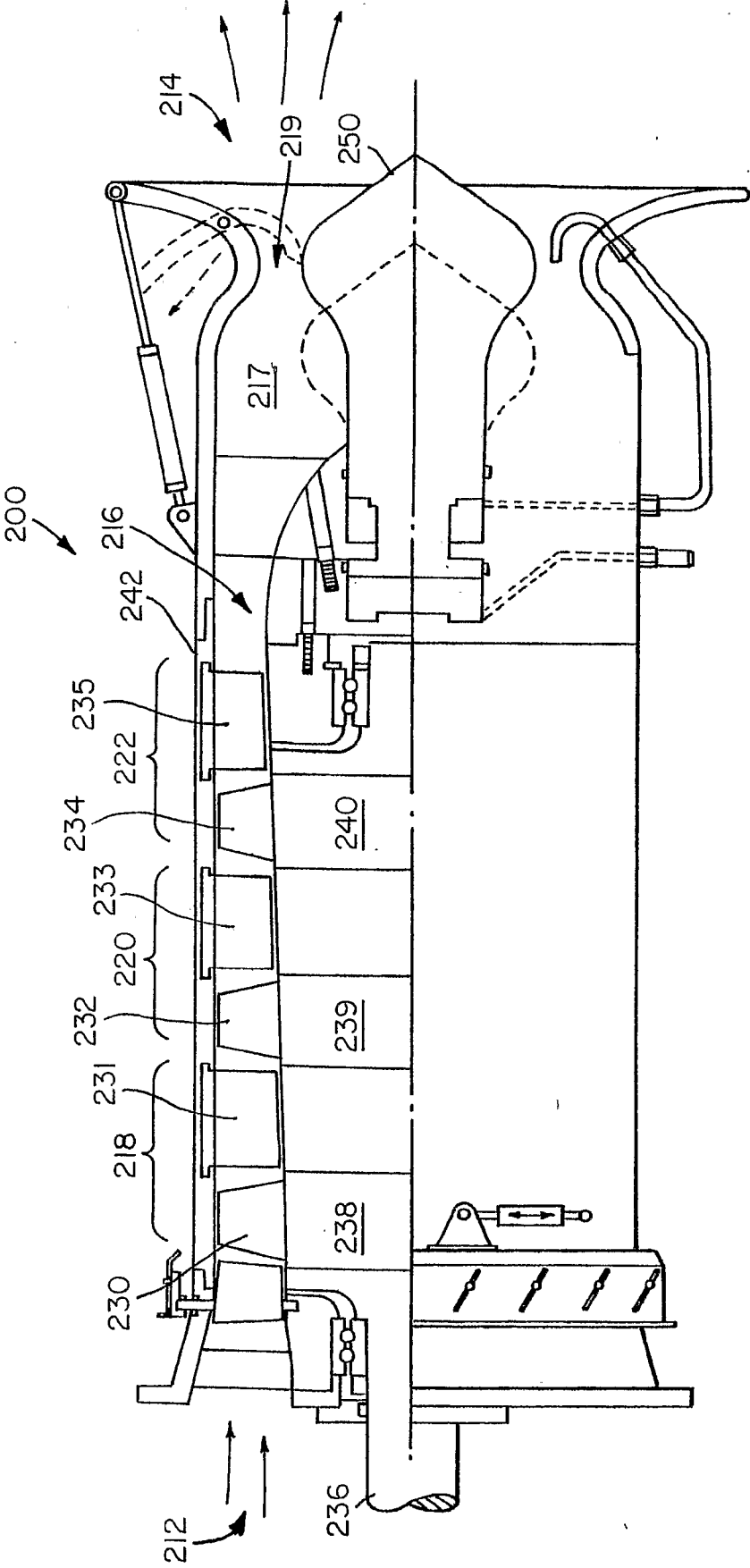

FIG. 2A

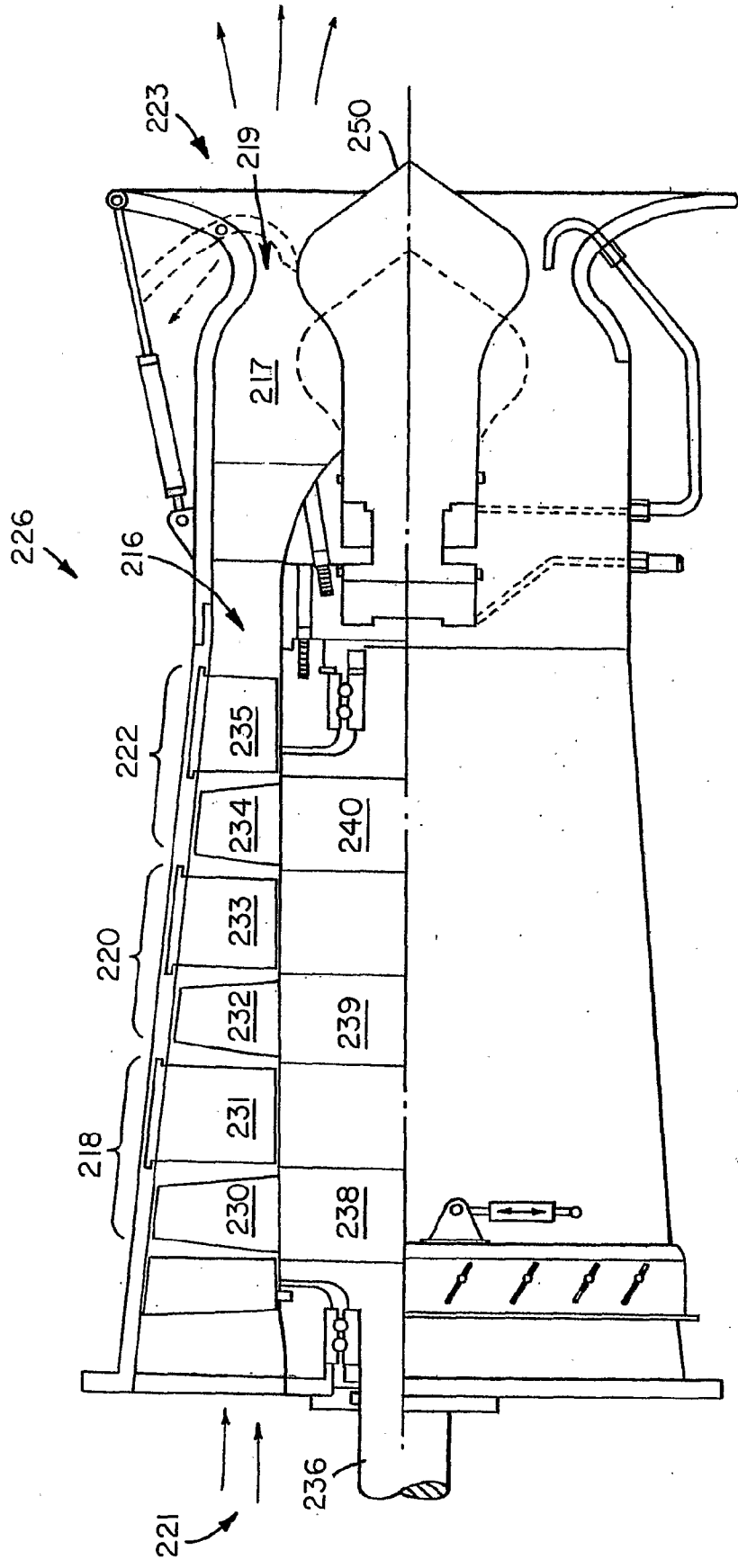

FIG. 2B

FIG. 3

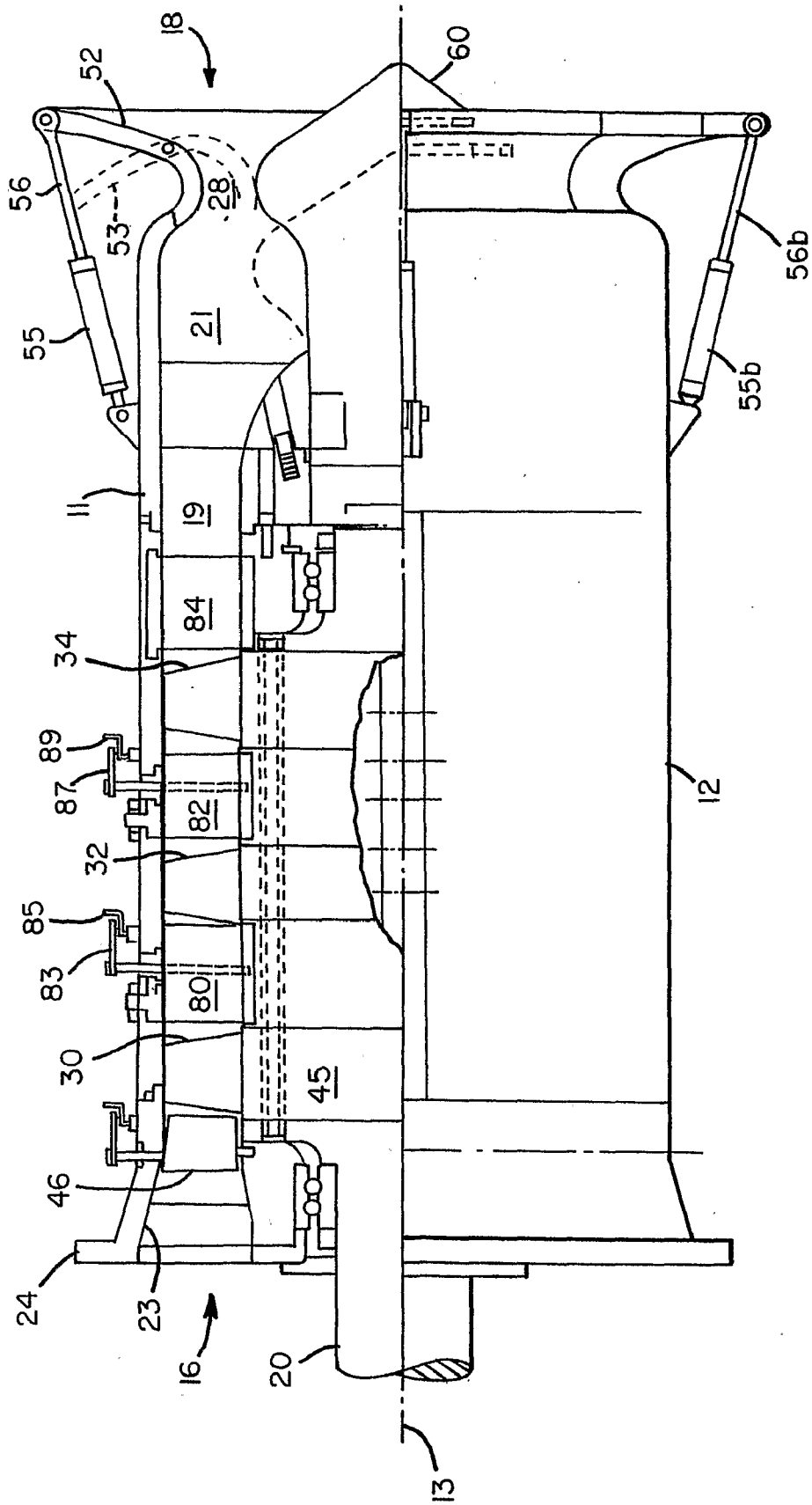

FIG. 5

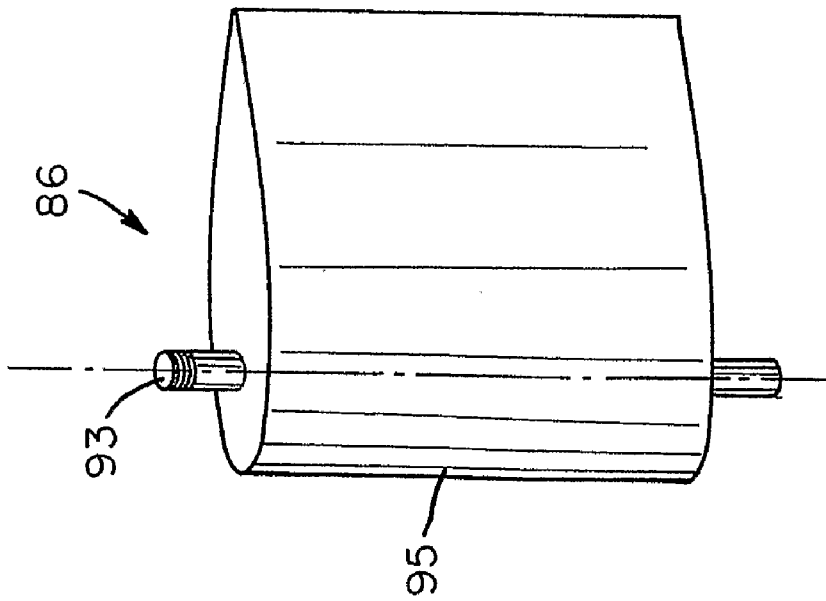

FIG. 4

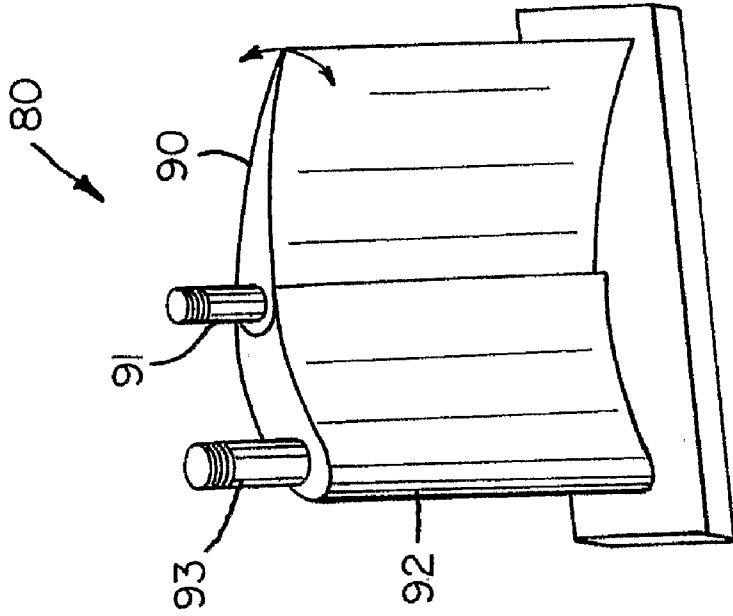
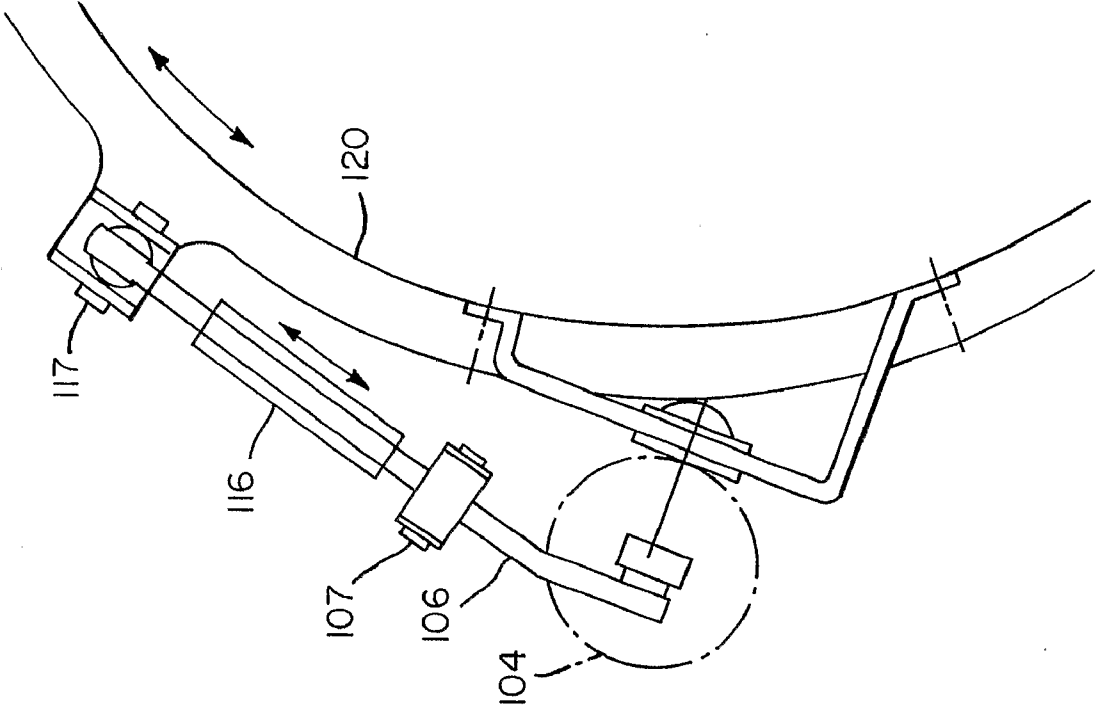

FIG. 7A



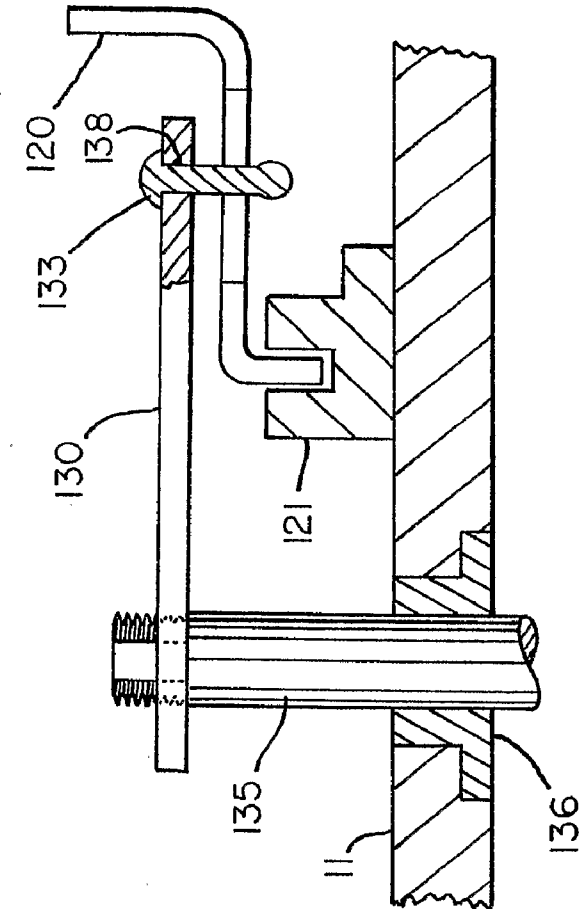

FIG. 7B

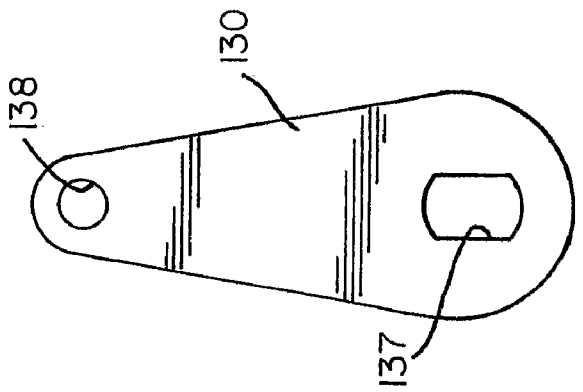
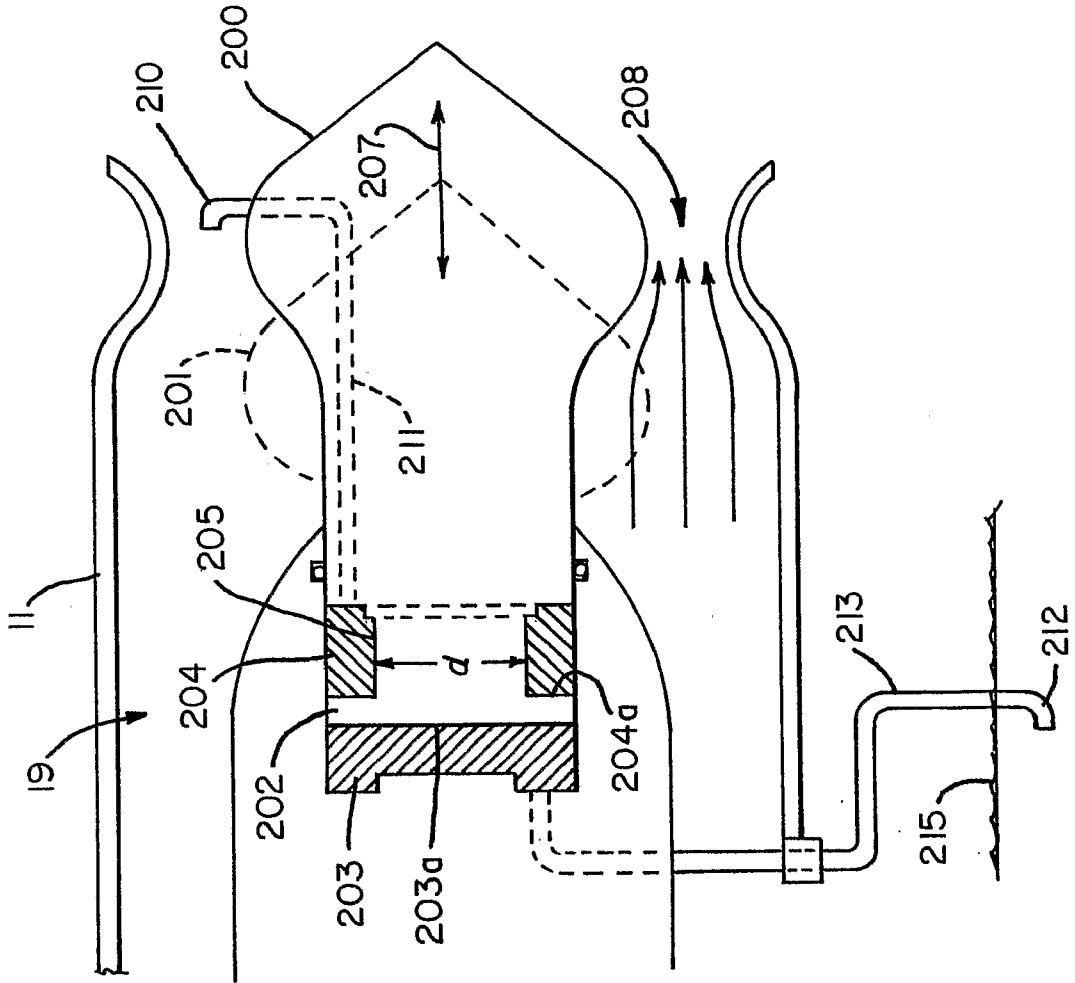

FIG. 7C

FIG. 8



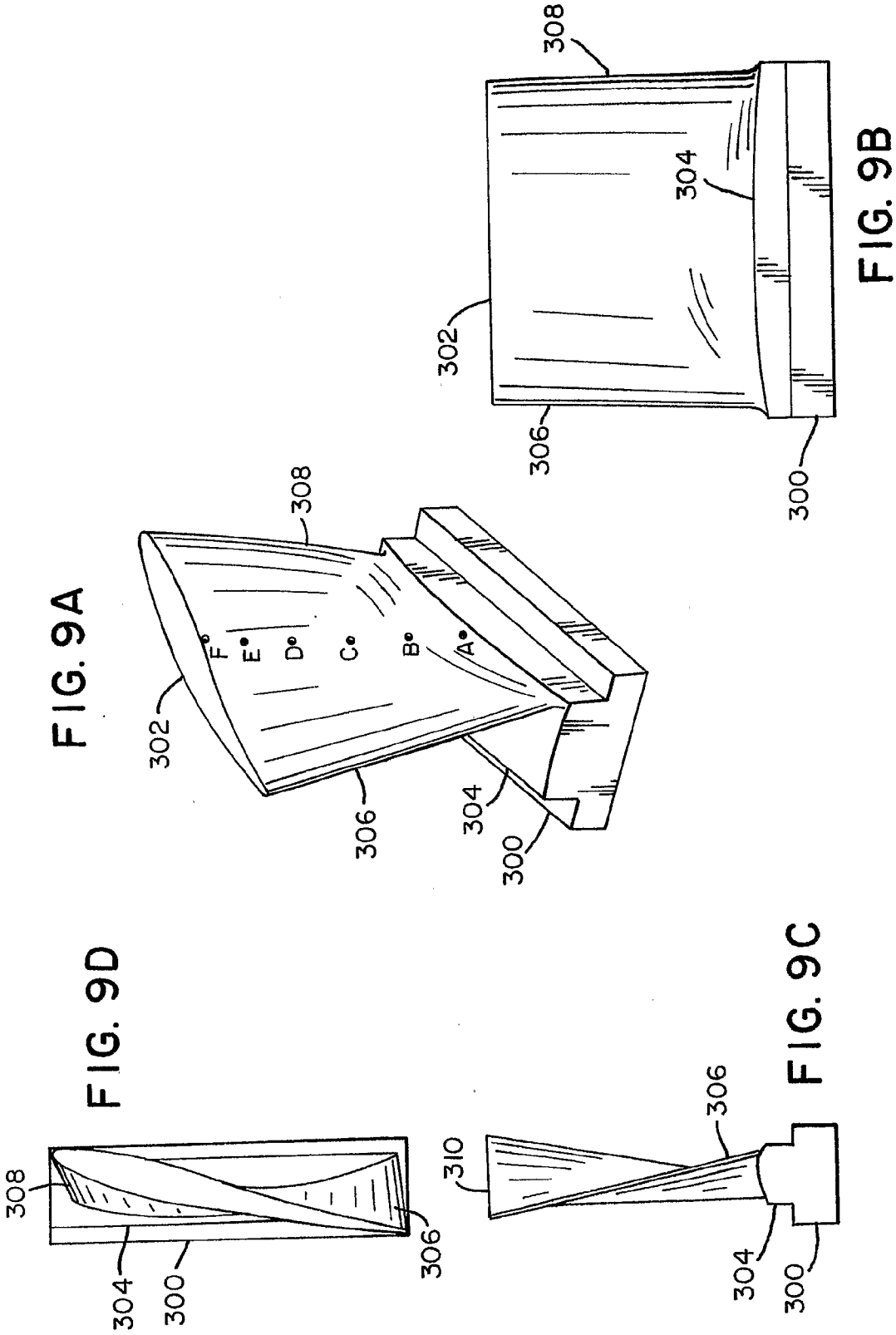

FIG. 9A

FIG. 9B

FIG. 9D

FIG. 9C

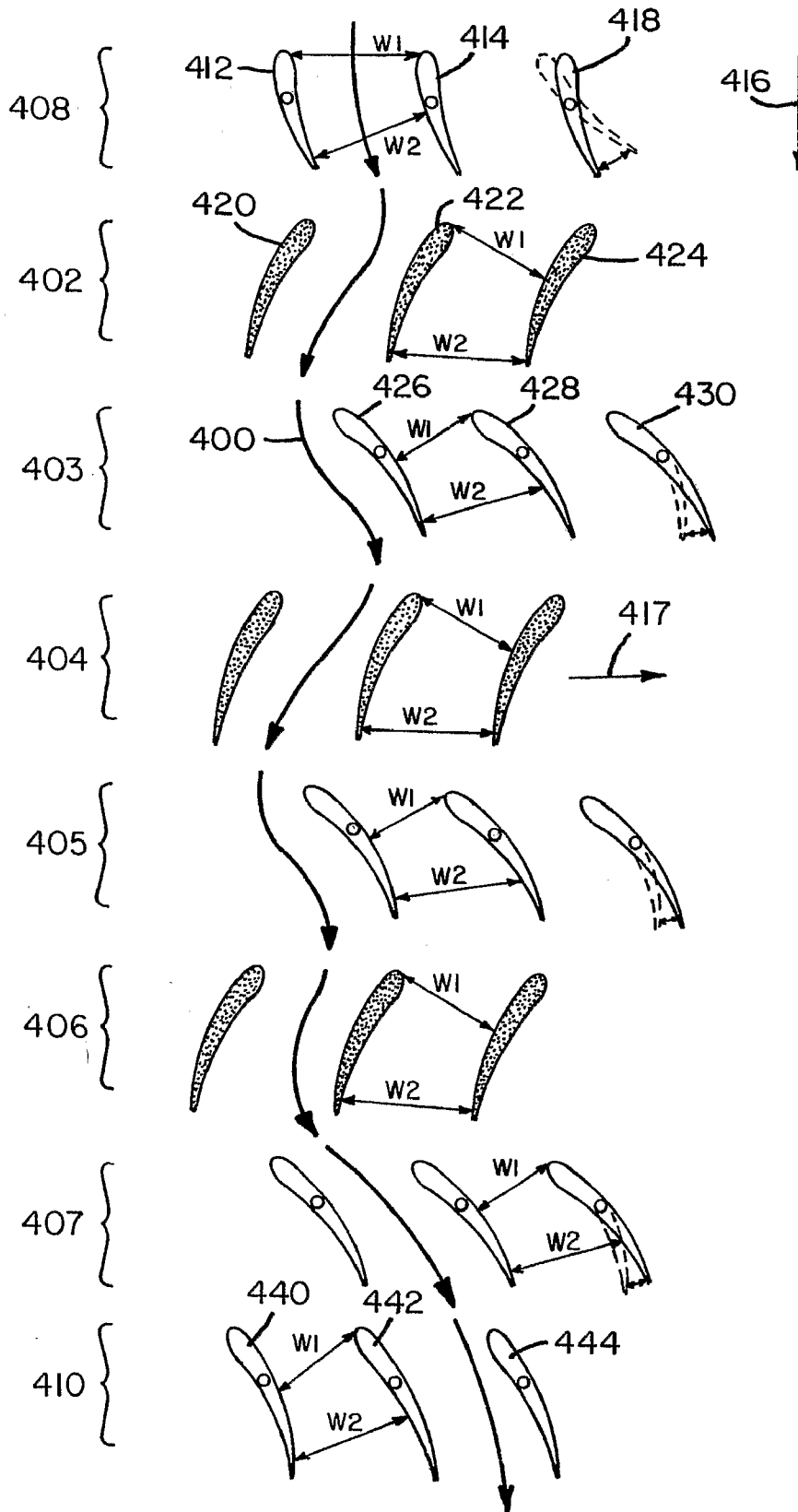

FIG. 10

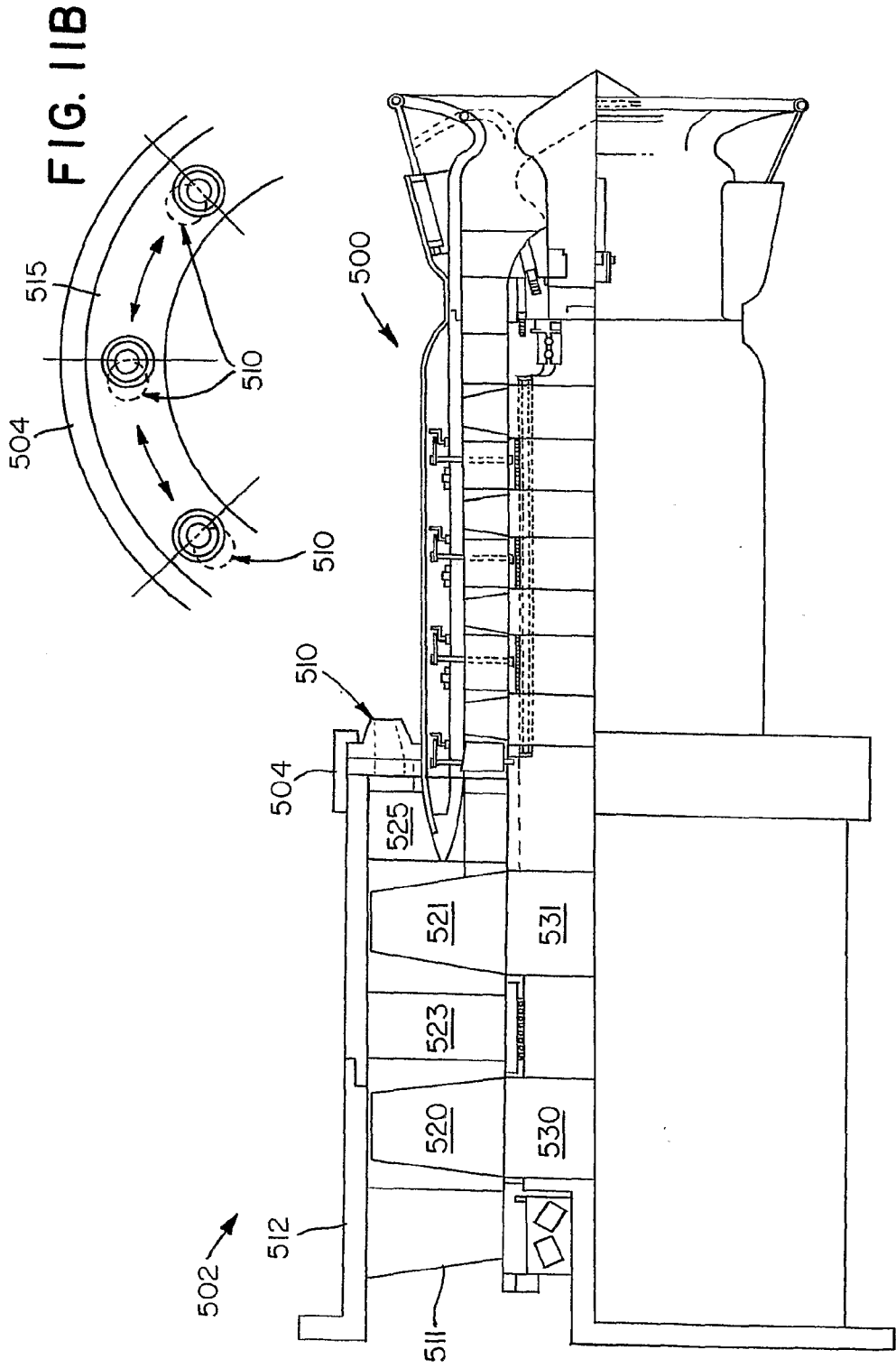

FIG. IIA

FIG. IIB

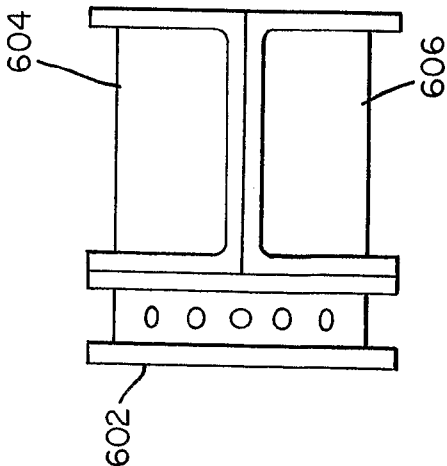

FIG. 12A

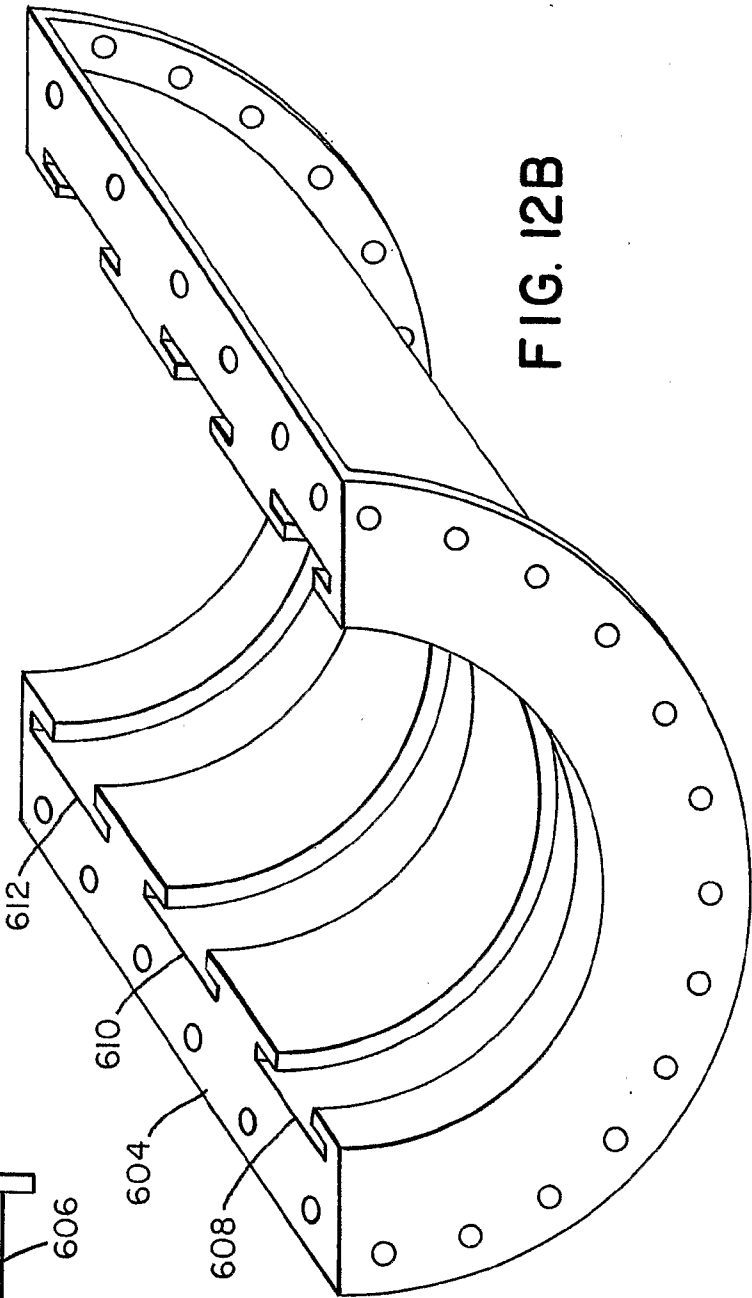

FIG. 12B

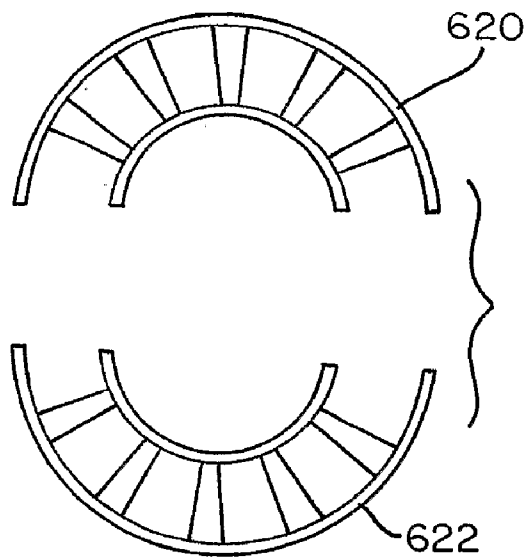

FIG. 12C

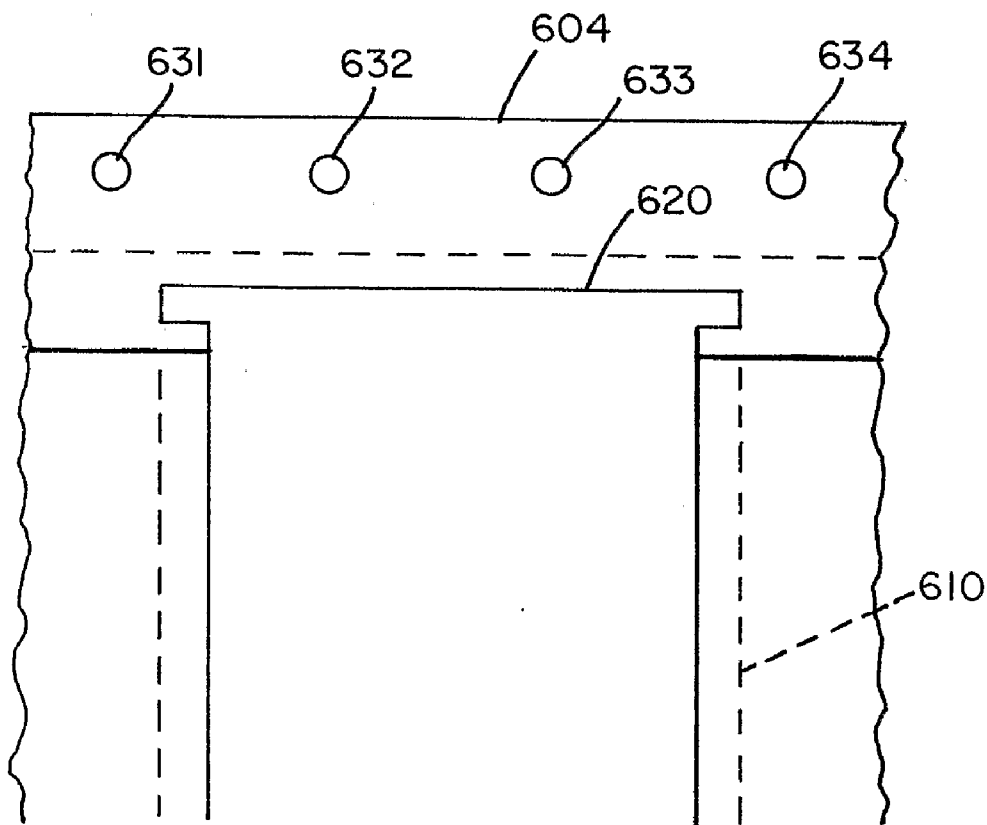

FIG. 13B

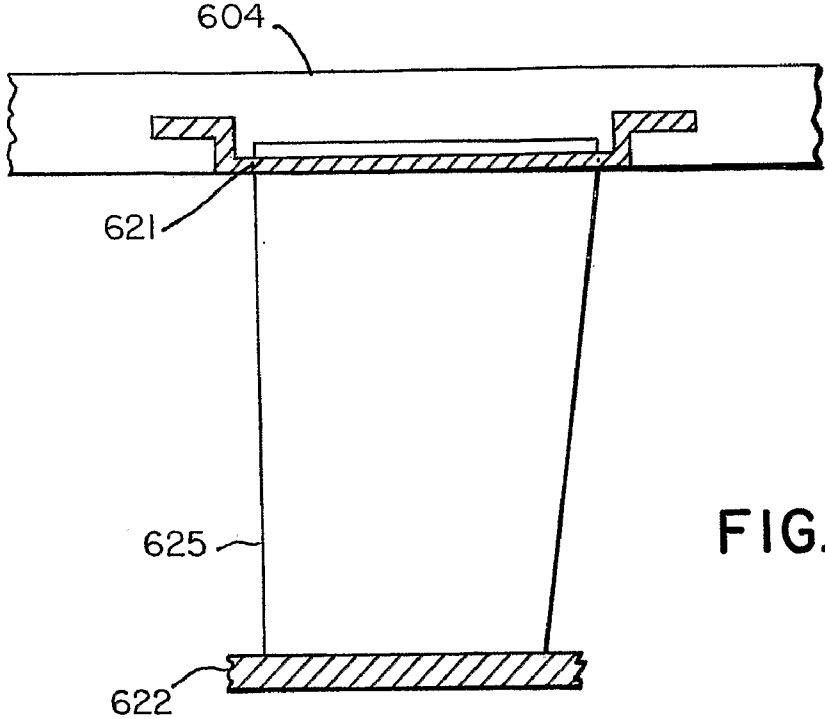

FIG. 13C

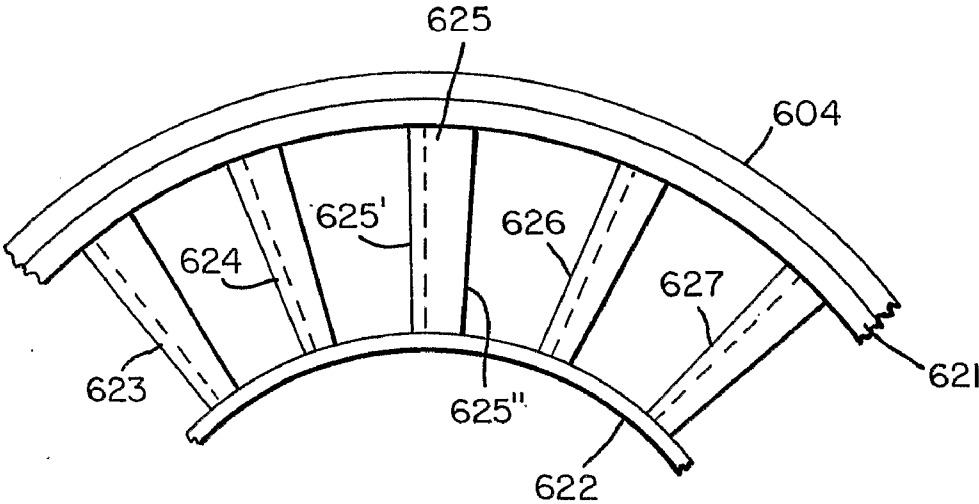

FIG. 13A

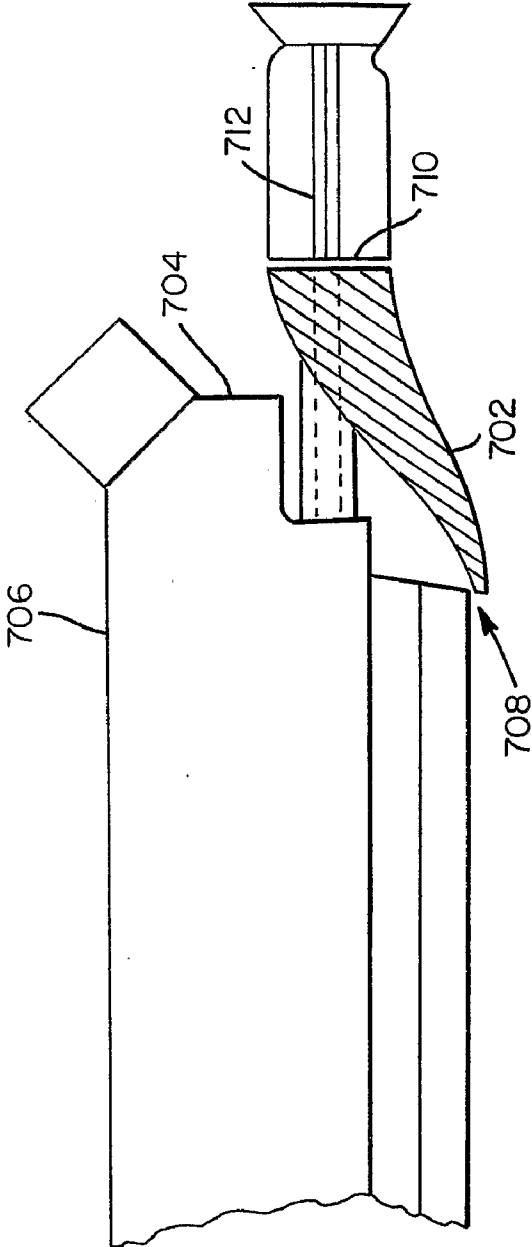

FIG. 14A

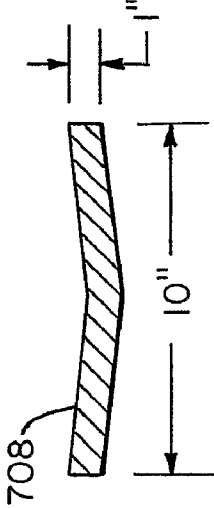

FIG. 14B

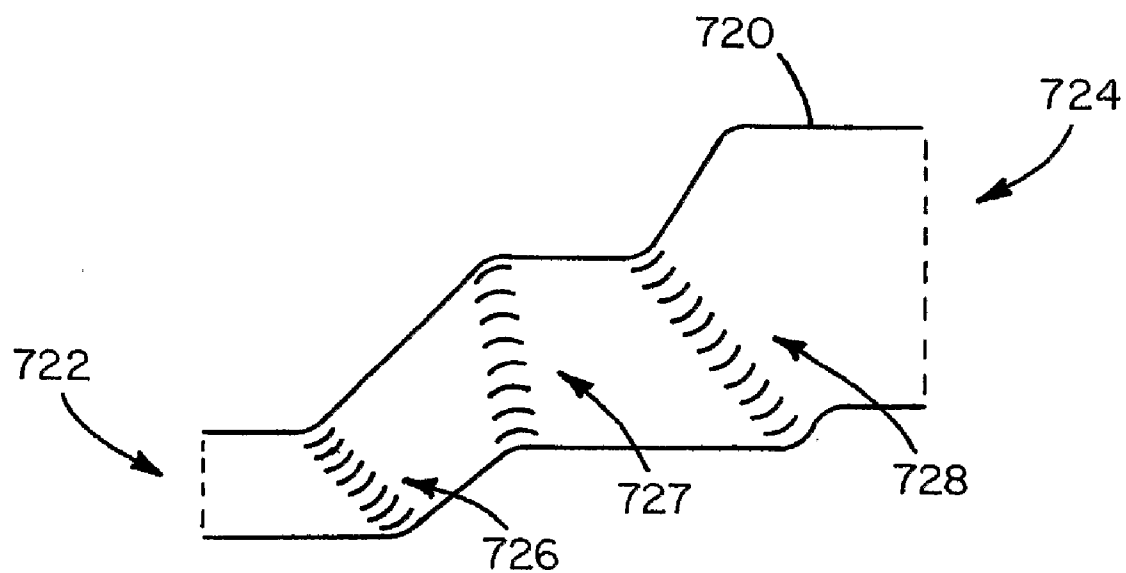

FIG. 15

AXIAL FLOW PUMP AND MARINE PROPULSION DEVICE

BACKGROUND

[0001] The present invention is directed to an axial flow pumping device and method, as well as an application thereof to achieve efficient marine propulsion.

[0002] In a multistage axial flow pump having two or more impeller stages, a certain amount of energy is transferred from a power plant to working fluid (e.g., water) at successive stages. Pressure is essentially stepwise increased at the succeeding stages until discharge of the working fluid through an outlet nozzle whereby to generate thrust. Increased pressure inside the pump suppresses damaging cavitation that may otherwise act upon the impellers. An axial flow pump differs from a more voluminous centrifugal or mixed-flow pump that is generally limited to single stage. Thus, an axial flow pump, if properly designed, may have a higher power density than conventional pumps. Apart from use in marine propulsion, other applications of the present invention include high volume pumps for fire or flood control, irrigation, and in large cooling towers requiring extremely high volumes or pressures.

[0003] In marine applications, design parameters of the propulsion pump are ideally matched with engine torque and speed, i.e., the engine power or performance curve. Most engines, however, have only a single optimum operating speed that delivers peak horsepower and another single operating speed for peak efficiency, which may not optimally match the desired thrust and/or hull speed of the vessel. Such desired hull speed or thrust generally varies with vessel loading, sea state conditions, and/or temperature and density of the ocean. Thus, certain inefficiencies inherently exist in conventional engine-propulsor combinations during operation of a vessel.

[0004] To compensate for such inefficiencies during the desired operating condition, it has been known to vary the pitch rotor blades in a pump's impeller section according to optimum torque, speed, or fuel efficiency of the engine. It is also known, but not necessarily applied to marine propulsion, to include fixed stator vanes between impeller sections of a multi-stage pumping device to counteract whirl or rotational velocity that rotor blades impart to the fluid, such as that disclosed by U.S. Pat. Nos. 5,755,554 and 5,562,405 (both issued to Ryall). The stator vanes has the effect of redirecting fluid flow to achieve a desired angle-of-attack of fluid acting on rotor blades in the succeeding stage, but such prior stator vane designs significantly increased internal friction. Ryall, for example, provides a substantially constant absolute velocity in flow passages between fixed stator blades. Due to their geometric structure, prior stator vane designs endured losses in efficiencies and generally operated, at best, around 65 to 72% propulsive efficiency.

[0005] The present invention, in part, takes advantage of the relationship between static and ram pressure, that is, the fact that the total pressure at within the pumping device (as well as at the pump's intake and discharge) comprises the sum of hydrostatic (static) of the pumped fluid plus the impact (ram) pressure imparted to the fluid by the impellers. It is also known the extent of internal frictional losses, due to barrier layer effects of the fluid transgressing internal components of the pump, increases exponentially with fluid

speed. At the pump inlet, a diffuser may be used to alter static pressure before water enters the impeller section. Also, it was not heretofore known, among other things, to alter the static pressure component of total pressure between rotor stages (by impeller design or geometric shape of the pump housing); to provide a low pressure booster for pumping mechanism; or to provide variable pitch stator vanes or a variable inlet guide vanes that mechanically reconfigure the pump to compensate for variations or operating characteristics of the power plant, desired mission profile, ship velocity or loading, water density or water temperature changes.

SUMMARY OF THE INVENTION

[0006] Thus, one aspect of the invention comprises a multistage axial flow pump that includes an outer housing, a substantially annular chamber within the housing that conveys working fluid (e.g., water) from an inlet to an outlet, multiple stages within the chamber that may each include a rotor section and a stator section. Stator vanes in the stator section may be fixed relative to housing and have a geometrical shape to define a fluid flow path having a cross-sectional area that increases as the fluid transgresses the stator section in the downstream direction whereby to increase static pressure. Optionally, variable internal geometry may be provided to reconfigure the pump parameters to match desired operating conditions of a vessel. For example, the stator vanes may optionally have variable pitch and the chamber may optionally include a variable nozzle having a discharge area (i.e., throat) that is controlled to optimally match the water jet discharge speed with the vessel speed. In yet a further aspect of the invention, a set of variable inlet guide vanes controls inlet fluid flow by changing the inlet area and/or whirl angle of incoming fluid. Such variable geometry enables the propulsion device to match a wide range of prime movers of different power.

[0007] The invention also includes a method implemented by the pumping device. One aspect of the method includes providing an actuator that varies the throat area of the discharge nozzle, detecting respective pressures associated with the discharge velocity and speed of the vessel, and using the respective pressures to drive the actuator to an equilibrium position that defines a desired optimum throat area of the discharge nozzle according to the instantaneous speed of the vessel. Other aspects are set forth in the claims.

[0008] In another aspect of the present invention, it was recognized that if a trade-off is made between static and ram pressure by increasing static pressure and reducing ram pressure using a diffuser-type annular chamber between stages of a multi-stage pumping device (with total pressure remaining constant), inherent frictional losses can be significantly lowered since friction exponentially decreases with fluid speed. This results in a more efficient propulsion device. Thus, an aspect of the invention also comprises a multi-stage pumping device, such as that described in U.S. patent application Ser. No. 10/801,705, having diffuser-like chamber between stages to control static and ram pressures according to desired a relationship. Construction of either the housing or the annular chamber may be varied where the effective area of the chamber in a direction normal to fluid flow is progressively increased or decreased. The height of the stator and rotor blades is correspondingly varied according to the height (clearance between the shaft wheel and housing) within the annular chamber.

[0009] Other aspects of the invention are pointed out by the appended claims.

BRIEF DESCRIPTION OF THE DRAWINGS

[0010] FIG. 1 is partial cut-away view of a multistage axial flow propulsion or pumping device according to one embodiment of the present invention that includes three rotor-stator stages, variable geometry inlet guide vanes, a thrust reversing/steering mechanism, variable-area discharge nozzle, and a mechanism to control nozzle discharge area.

[0011] FIG. 2A shows an axial flow pumping device where, by virtue of increasing drive wheel diameters in the downstream direction, the effective area of an annular chamber decreases in the rotor-stator sections, and then the effective area of the annular chamber substantially increases prior to reaching the discharge nozzle thereby converting ram pressure of the working fluid to static pressure (e.g., by slowing down fluid speed and decreasing internal frictional losses).

[0012] FIG. 2B shows an axial flow pumping device where, by virtue of decreasing housing diameter but constant drive wheel diameter in the downstream direction, the effective area of the annular chamber decreases in the rotor-stator sections, and then the effective area of the annular chamber substantially increases prior to reaching the discharge nozzle thereby converting ram pressure in the working fluid to static pressure (e.g., by slowing down fluid speed and decreasing internal frictional losses).

[0013] FIG. 3 shows a partial cut-away view of an alternative design of a multistage propulsion or pumping device according to yet a further aspect of the present invention, which includes variable pitch stator vanes in order to provide adaptive power-torque conversion between an engine and propulsion device.

[0014] FIG. 4 shows a second, segmented stator vane design that may be incorporated in the propulsion device of FIG. 3, according to yet another aspect of the present invention.

[0015] FIG. 5 shows a first stator vane design that may be incorporated in the pumping or propulsion device of FIG. 3, according to yet another aspect of the present invention.

[0016] FIG. 6 depicts actuator and control mechanisms that may be incorporated in a multistage propulsion device to control variable inlet guide vanes and/or the pitch of stator vanes according to yet other aspects of the present invention.

[0017] FIG. 7A shows a front view of one embodiment of a control ring and actuator that may be used to control the pitch of variable pitch stator vanes of an axial flow pumping or propulsion device according to yet a further aspect of the present invention.

[0018] FIG. 7B shows a side view of slip ring and control arm mechanism to vary the pitch angle of stator vanes according to an aspect of the present invention.

[0019] FIG. 7C is a plan view of a control arm of FIG. 7 that controls the pitch angle of the stator vanes.

[0020] FIG. 8 shows a piston-cylinder drive and pressure balancing mechanism to vary the discharge area of the

multistage propulsion device according to sensed water jet velocity and vessel speed according to yet a further aspect of the present invention.

[0021] FIG. 9A is a rear perspective view of an exemplary rotor blade the may be used with the illustrative pump or propulsion device.

[0022] FIG. 9B is a side view of the rotor blade of FIG. 9A.

[0023] FIG. 9C is a rear view (viewed from a downstream position) of the exemplary rotor blade of FIG. 9A.

[0024] FIG. 9D is a top view of the exemplary rotor blade of FIG. 9A.

[0025] FIG. 10 is a conceptual view of a series of rotor-stator sections of an exemplary three-stage pumping or propulsion device that optionally includes a set of inlet guide vanes and a set of exit guide vanes.

[0026] FIG. 11A shows an improvement that comprises a low pressure booster section preceding the inlet of the exemplary propulsion device of FIG. 3 or FIG. 1, which enables increased mass flow rates to enhance acceleration from zero to slow speeds and/or higher propulsive efficiencies at low to moderate vessel speeds.

[0027] FIG. 11B shows variable discharge nozzles of the booster section of FIG. 11A which variably open and close (manually or under automatic control) according to vessel speed.

[0028] FIGS. 12A, 12B, and 12C illustrate a split housing design of a multistage axial flow pump adapted to receive stator vane groups having a desired fixed pitch in order to adapt a given pump design to a wider range of power plants.

[0029] FIGS. 13A, 13B, and 13C show details of the stator vane assembly used in the split housing design of FIGS. 12A, 12B, and 12C.

[0030] FIGS. 14A and 14B illustrates an inlet diffuser that may precede a pumping device, such as an multistage axial flow pumping device, in order to boost or increase hydrostatic pressure by recovering a portion of ram pressure brought about by vessel speed.

[0031] FIG. 15 shows a specific embodiment of an inlet diffuser of FIGS. 14A and 14B having stepped sections and deflector vanes therebetween to effectively recover or convert ram pressure in a preceding section to static pressure in a succeeding section.

DESCRIPTION OF ILLUSTRATIVE EMBODIMENTS

[0032] FIG. 1 shows a first embodiment of a pump or propulsion device 10 having a substantially cylindrical outer casing 12, an inlet 14 through which a substantially incompressible working fluid (e.g., water) enters, and an outlet 18 that discharges the working fluid as an accelerated jet discharge 22. In marine, firefighting, irrigation, or flood control applications, the working fluid is water. Device 10 includes an internal annular chamber 19 extending along and circumscribing an axis 13. Chamber 19 conveys working fluid from inlet 14 to outlet 18 under power imparted by multiple pumping stages each of which may comprise a rotor section and an intervening stator section. Respective

rotor sections of device **10** include a rotor blade **30**, **32**, or **34** attached to a corresponding rotating wheel, such as wheel **45** centered on axis **13**. Blade **30** is coupled to and rotated with wheel **45**. Multiple concatenated wheels and an internal wall of casing **11** define the annular chamber **19** within the cylindrical housing of device **10**. Although a cylindrical housing is preferred, housing **12** may have a non-cylindrical shape.

[0033] Concatenated wheels are driven in unison by drive shaft **20**, which may be coupled to any one of a number of conventional engines. Mounting flange **24** couples device **10** to a fluid conduit that supplies working fluid to device **10**. Forward and aft sets of thrust bearings **15** and **17** support the shaft along axis **13** within casing or housing **12**. Thrust bearings **15** and **17** also absorb or counteract a relatively large opposing axial force between housing **12** and shaft **20** developed by multiple rotor sections during operation of the device. Preferably, each of the rotor blades **30**, **32**, and **34** radially extends from axis **13** of an associated rotating wheel to a given design height, width, thickness, and twist angle so as to impart maximum energy to a working fluid.

[0034] Stator vanes **40**, **42**, and **44** lay in respective stator sections following respective rotor sections but instead are fixedly attached relative to wall **11** of the casing or housing **12**, rather than being attached to a rotating wheel. Vane design is similar to the blade design of the rotors. Stator vanes **40**, **42**, and **44** serve to redirect and/or diffuse the flow of working fluid from the rotor blades, e.g., rotor blades **30**, **32**, and **34**, in the preceding section. In operation, rotor blades impart energy to the working fluid by accelerating fluid in a partial tangential and partial axial direction relative to axis **13**, thus increasing the ram or impact pressure of the fluid as it enters the next stage. The stationary vanes redirect the working fluid in an opposed tangential direction, e.g., to counteract whirl imparted by the preceding rotor section, as the fluid flows in annular chamber **19** along axis **13** towards outlet **18**.

[0035] According to an important aspect of the invention, the stator vanes are arranged to effectively reduce the velocity of the working fluid but retaining total pressure therein by providing an expanding area between vanes as fluid flows through the stator section. In part, this is accomplished by providing, in embodiments illustrated in FIGS. **4** and **5**, an airfoil-shaped stators (with or without a segmented flap portion) having a thicker leading edge portion and a thinner trailing edge portion. Other geometric shapes achieving the same or similar results may also be utilized. In one practicable embodiment, the flow path area in a direction of fluid flow through the stator section may increase, for example, from a factor of about 1.15 to 1.5 (e.g., 23%), more or less. Such expanding flow path area between stator vanes correspondingly decreases the working fluid speed and simultaneously increases the static pressure of the fluid prior to entry into the next rotor stage. Fluid velocity decreases proportionately, more or less. However, total pressure of the fluid, i.e., static pressure plus impact or ram pressure imparted by the preceding rotor section, remains relatively constant (except for minor frictional losses) within the stator section. Thus, the geometric arrangement of the stator vanes relative to fluid flow enables a speed reduction of the working fluid without sacrificing total pressure thereby reducing internal frictional and flow losses associated with higher fluid speeds. The arrangement of the stator vanes also

increases static pressure of the fluid prior to the next stage thereby providing a higher initial static pressure upon which the rotor blades work in order to impart energy. Thus, the rotor blades in effect deliver further impact or ram energy to the working fluid by increasing pressure derived from the preceding stage. Successive stepwise increases in static pressure provided by the stator sections and successive recovery and supplementation of impact or ram energy provided by successive rotor sections significantly increase the final working fluid pressure at the discharge nozzle and thus significantly increase the overall effectiveness of the pump or propulsion device.

[0036] Preferably, device **10** has three or more stages although two stages may also suffice. Each rotor section may or may not include a subsequent stator section. Fluid enters the next or succeeding stage at essentially the same total pressure of the fluid being discharged from the preceding stage. The rotor sections impart additional pressure to the fluid at each stage. Stepwise increases in pressure is repeated as many times as necessary to attain the desired design point pressure at region **21**, which supplies pressurized fluid to an annular discharge nozzle. The discharge nozzle includes an axially variable plug **60** that controls the size of the area of throat **28** between deflector **52** and plug **60**. Preferably, region **21** defines an annular nozzle that is convergent to eject water at an increased velocity thereby generating propulsive thrust. Thrust, which can be measured in pounds, equals mass flow times velocity.

[0037] In a preferred embodiment, the size or area of throat **28** in the annular discharge nozzle is variable and controllable, and may be used to trim the water jet discharge velocity to maximize boat velocity.

[0038] Inlet **16** of device **10** preferably includes a series of inlet guide vanes **46** that serve to control, redirect, or throttle incoming fluid flow and/or to change the angle of attack of incoming fluid. This alters the load on the rotor blades in the first stage of device **10**. Due to differential cross-sectional areas of inlet duct **26**, the velocity of water at entry into the inlet duct is lower than the velocity of the water entering the casing of device **10**. In the inlet duct, there is a transition section **23** from larger to smaller area so that the difference is not so abrupt as to cause losses from eddies thereby maintaining streamline fluid flow. A principal embodiment of the invention does not require inlet guide vanes **46** in the first stage although other embodiments do. In a fixed inlet guide vane embodiment, the vanes direct water flow into the first rotor-stator stage **30**, **40** at a prescribed angle and function as a flow director. In an embodiment utilizing variable inlet guide vanes, i.e. variably controlled vanes actuated by actuator ring **48** and actuator **47**, the flow angle of water entering the first rotor stage of blade **30** is variable. This not only changes the incidence angle of the working fluid entering the pump but also changes the amount of flow and therefore the inlet guide vanes function as a throttling mechanism. Thus, guide vanes **46** provide mass flow throttling of the working fluid, and include control linkage to rotate the vanes **46** about $\pm 30^\circ$ from a neutral position according to a desired mass flow rate.

[0039] At the discharge end of device **10**, the axial position of nozzle plug **60** is controllable to effectively open or restrict the water jet throat area **28**. When plug **60** is extended, as shown in FIG. **1**, the area of throat **28** is smaller

thereby resulting in a faster water discharge speed for a given mass flow rate. A retracted nozzle plug **62**, shown in phantom, opens the area of throat **28** to a larger area and thus lowers water discharge speed for a given constant mass flow rate. A plug position control mechanism including pressure sensors, such as pitot tubes **66** and **68**, provide balanced pressure settings in a piston drive head **64** to attain optimum positioning of nozzle plug **60** in relation to speed, loading, or other parameters of the vessel.

[0040] When deployed in marine applications, steering may be accomplished by redirecting the water jet at the discharge nozzle. In the embodiment of FIG. 1, the device **10** may include thrust reversers on each side thereof in the form of a deflector **52** hydraulically actuated by cylinder **55** and control arm **56**. When driven to a reverse position to seal off the throat **28** by engaging the head of plug **60**, as shown by deflector **53** (shown in phantom), fluid flow is redirected from region **22** and is forced in a direction **58** (also shown in phantom). When corresponding deflectors are provided at four quadrants of outlet **18**, simultaneously actuating the deflectors to a reverse position produces a reverse thrust to reverse the direction of travel of the vessel. Respective deflectors on left and right sides of the vessel may be independently operated to provide steering. In addition, the discharge region of device **10** may be mounted on a gimbal to effect redirection of thrust to provide steering.

[0041] FIG. 2A shows an axial flow pumping device **200** where, in the downstream direction, the effective area of the annular chamber decreases in the rotor-stator sections **218**, **220**, and **222** due to increasing diameters of drive wheels **238**, **239**, and **240**. This has the effect of decreasing the effective area of the annular chamber **216** in the downstream direction thereby increasing fluid flow speed. However, upon reaching region **217** of the annular chamber, the effective area abruptly increases thereby substantially increasing the effective area of the annular chamber prior to reaching the throat **218** of discharge nozzle **250**. This abrupt increase in area converts ram pressure to static pressure (slowing down fluid speed and decreasing internal frictional losses) within the propulsor. In the embodiment of FIG. 2A, it is also seen that the height of the rotor blades and stator vanes decrease in the downstream direction. Variable pitch stator or rotor vanes (either or both being variable) may be employed to effect power delivery to the fluid according to the desired fluid speed within the respective rotor-stator sections.

[0042] FIG. 2B shows an axial flow pumping device **230** where, in the downstream direction, the effective area of the annular chamber **216** also decreases due to a decreasing diameter of housing **242**, but the diameters of drive wheels **238**, **239**, and **240** remain constant. Here, it is seen that the heights of the respective rotors **230**, **232**, and **234**, as well as the height of the respective stators **231**, **233**, and **235** decrease in the downstream direction. This construction also effects and increase in fluid speed in the rotor-stator sections, but at region **217**, the effective area of annular chamber **216** abruptly increases thereby substantially slowing down fluid speed r prior to reaching the throat **219** of discharge nozzle **250**. Ram pressure of the high-speed fluid is converted to a high static pressure at lower fluid speed thereby reducing internal friction and providing the desired thrust at nozzle **250**. Similarly, variable pitch stator or rotor vanes (either or both being variable) may be employed to effect power

delivery to the fluid according to the desired fluid speed within the respective rotor-stator sections.

[0043] In an alternative design, rather than providing an effective area of annular chamber **216** that progressively decreases in the downstream direction, the effective area of the annular chamber in the downstream direction may increase (rather than decrease) while transgressing the rotor-stator sections and then merge with a region **217** in a less abrupt transition. Such alternative design may be accomplished by varying the blade height or housing geometry, as explained in the earlier embodiment. Thus, the invention embraces various geometrical designs that take advantage of diffuser designs to trade off static and ram pressures, while maintaining constant total pressure, to improve efficiencies of a multi-stage axial flow pumping device.

[0044] FIGS. 3-5 shows yet another embodiment of a pumping or propulsion device in which, rather than providing "fixed pitched" stator vanes **30**, **32**, **34** (FIG. 1), variable pitch stator vanes **80** and **82** are provided. Control arms **85**, **89** control the effective pitch of vanes **80**, **82** upon tangential translation of linkages **83**, **87**. A control ring (not shown) actuates linkages **83**, **87** when rotated upon the outer casing **12**, and such rotational control may be implemented manually or under computer control in response to monitored operational parameters such as engine torque, vessel speed, velocity of the water jet, vessel loading, fluid density, or a combination thereof, in order to attain optimum performance or efficiency. The stator vanes may also be segmented into a stabilizer section **92** and a trailing section **90** that about a shaft **91**, as depicted in FIG. 4. Shaft **91** is preferably integrally formed with trailing section **90** of the stator vane. In an exemplary embodiment, trailing section **90** is designed to pivot plus or minus thirty degrees, more or less, about a neutral position. About twelve to fourteen stator vanes **80** are circumferentially and evenly spaced within the annular chamber **19**, which extend radially from axis **13** from about 3.0 inches to about 4.5 inches. A similar or smaller number of rotor blades may be used on each wheel.

[0045] In the exemplary embodiment of FIG. 3, the outer radius of the wheels, such as wheel **45**, defines the inner surface of annular chamber **19** at about 3.0 inches from axis **13** while the outer radius of chamber **19** is about 4.50 inches from axis **13**. Preferably, the height of the rotor blades and stator vanes is about 1.5 inches and the ratio of blade or vane height to its chord is about 1:1 or higher. The ratio of blade height to drum radius in the exemplary embodiment is preferably between 0.66 and higher, i.e., a blade height of at least $\frac{2}{3}r^d$ of the drum radius, or more. None of these exemplary dimensions, however, constitutes a limitation of the invention. This exemplary embodiment can be driven with a 1250 horsepower engine at a propulsive efficiency exceeding 84 to 86%. When used to pump water in other applications, the exemplary embodiment is designed to pump water over six hundred and fifty feet vertically at a flow rate of about 8500 gallons/minute.

[0046] Instead of using a segmented vane structure, vanes **80**, **82** may take on the form **86**, as depicted in FIG. 5, which is constructed much like a standard airfoil having a single section **95** that pivots about a shaft **93**. Shaft **93** is preferably integrally formed with vane **95**.

[0047] The material of the vanes and stator may comprise any of a variety of materials known in the art such as

titanium, bronze, a high carbon stainless steel, a composite material, or other material that is preferably non-corrosive and/or adapted for marine applications.

[0048] In addition, there is provided a “fixed pitch” exit guide vane 84 (FIG. 3) that is fixedly attached to wall 11 of housing 12.

[0049] FIG. 6 illustrates one type of mechanism to vary the pitch of stator vanes according to the variable pitch stator vane aspect of the invention where an actuator 100 under manual or automated control includes an actuator rod 102 that translates control arm 104 in direction 105 parallel to axis 13. A series of L-shaped linkages 106, 108 and 110 interconnect control arm 104 with respective pitch actuating turnbuckles 112, 114, and 116 to vary the pitch of inlet guide vane 46 as well as the pitch of a series of stator vanes, one of which is shown at 30. Turnbuckle 112 couples control ring 124 via flange 126, turnbuckle 114 couples control ring 122 via flange 128, while turnbuckle 116 couples control ring 120 via extension 129. The turnbuckles include a threaded adjustment rod that may be adjusted to properly align the pitch angle of the stator vanes and inlet guide vane relative to each other. Upon translation of control arm 104 in an axial direction, the trailing portion of variable pitch stator vane 30 (shown in cut-away view) changes pitch by pivot action of linkage 108 about pivot point 109. This action drives control ring 122 circumferentially around casing 12 via connecting flange 128. Circumferential movement of control ring 122 turns the stator vane 30 via arm 140. As indicated above, a preferred embodiment may vary the angular pitch of stator vane 30 (or trailing portion thereof) by as much as plus or minus twenty or thirty degrees. A similar action occurs with respect to control ring 120 to actuate the lever 130 to vary the pitch of the interconnected stator vanes underneath casing 12 (not shown). Levers 131 and 132, which are ganged to control ring 120 with other levers, similarly vary the pitch of interconnected stator vanes.

[0050] As apparent from the illustrated actuating mechanism, control of the stator vanes and the inlet guide vane 46 occur in unison for simultaneous pitch angle changes. Pitch angle changes alter the angle of attack of, and hence, the torque applied against or energy delivered to the working fluid by the rotor blades of the following section. Each rotor section thus stepwise increases the energy imparted to the working fluid. Control of the inlet guide vanes of ring 124 may, however, be separated from control of the stator vanes of rings 120 and 122. As control arm 104 axially translates, linkage 110 pivots about pivot point 111 to advance and retract turnbuckle 112, which drives control ring 124 via flange 126. Control ring 126 couples the shaft of inlet guide vane via actuating arm 150. Preferably, actuator 100 is controlled in a way to attain peak power output or peak propulsive efficiency of the pumping device as working fluid enters the inlet 16.

[0051] Thus, according to the structure of FIG. 6, the rotors are fixed pitch while the stators are variable pitch. The pitch-changing mechanism is simple in design, construction, and maintenance.

[0052] FIG. 7A depicts one of the control or actuator rings, i.e., actuator ring 120, in greater detail. As apparent, upon actuation of hydraulic or electrical actuator 104, angled link 106 rotates about a pivot point 107 to effect a vertical

excursion of turnbuckle 116 which, in turn, circumferentially rotates actuator ring 120 around casing 12 to alter the pitch angle of the stator vanes, e.g., stator vanes mechanically coupled with control arms 130, 131, and 132 of FIG. 6. FIG. 7B shows stator vane control arm 130 in operative relation with actuator ring 120 and shaft 135 of a variable pitch stator vane. There, a slot in guide block 121 enables the actuator ring 120 to circumferentially rotate when actuated by turnbuckle 116 (FIG. 6) that, in turn, sweeps the end of control arm 130 through slot 134 via locking pin 133 extending through hole 138 of control arm 130. This action effects rotation of shaft 135, which is interlocked with control arm 130 via inset 137, as further illustrated in FIG. 7C. Bushing 136 confines shaft 135 to an axial position and seals water pressure inside casing 11.

[0053] FIG. 8 illustrates yet an addition aspect of the invention, which is designed to optimally match boat speed with water jet speed when deployed in marine applications. The apparatus and method may be used to automatically or manually control the throat of the discharge nozzle by altering the axial position of nozzle plug 60 to attain optimum propulsive efficiency according to boat speed and water jet speed. In determining how such control is to be implemented, sea level static thrust= $W/g \cdot V$. The net thrust of a vessel underway, however, is characterized by:

$$\text{Thrust } T = W/g \cdot (V_j - V_b) \tag{1}$$

where thrust T=mass flow rate in weight of working fluid (i.e., water) per unit volume per second, g=gravitational acceleration constant (e.g., expressed as 32 ft/sec²), velocity V_j=exit velocity of the fluid jet at the discharge nozzle, and velocity V_b=exit velocity of the vessel relative to the water. The exit velocity exerts a dynamic pressure P_d equal to ½ the density Rho of the working fluid times the velocity squared divided by two times the acceleration of gravity, or

$$P_d = (Rho \cdot V^2) / 2g \tag{2}$$

[0054] It is known that dynamic pressure P_d at the discharge nozzle is directly proportional to the velocity squared V² of the fluid. Propulsive efficiency (N_p) equals the useful thrust output divided by the combination of useful thrust output and losses (e.g., frictional losses). So, if V_b represents the velocity of boat and V_j represents the velocity of the water jet at the discharge nozzle, then the Absolute (or effective) Discharge Velocity V_a equals V_j-V_b. Therefore, propulsive efficiency

$$N_p = ((W/g) \cdot V_a \cdot V_b) / \{(W/2g) \cdot (V_j^2 - V_b^2)\} \tag{3}$$

[0055] Simplifying the expression of N_p, then

$$N_p = 2 / (1 + V_j / V_b) \tag{4}$$

[0056] Therefore, it is seen that the propulsive efficiency N_p is indirectly proportional to the ratio of the water jet and boat velocities. Propulsive efficiency N_p is also proportional to the ratio of the dynamic pressures generated by the jet and boat velocities, i.e., N_p=P_d(jet)/P_d(boat). Using equation (4) above, the propulsive efficiency N_p is 67% for a hull design speed of 30 knots at a water jet speed of 60 knots.

[0057] FIG. 8 illustrates one type of mechanical arrangement to capture these relationships and control nozzle discharge area, or the speed of the water jet in relation to boat speed. The fluid discharge area is defined by throat 208, which is confined by head 200 of the nozzle plug and the internal walls of casing 11 at the throat area. Nozzle head

200 axially moves in a direction indicated by line **207** to alter the effective area of throat **208**, which extends within an annular path of chamber **19**. A first pitot sensor **210** senses pressure of the working fluid in throat **208** while a second pitot tube **212** senses pressure of the water in the hull ship stream that is exerted by boat speed. Pitot tube **212** extends downwardly below water level **215** and opens to the direction of travel of the vessel. A line **211** communicates sensed pressure of pitot tube **210** with nozzle head retraction chamber **204**. Flex line **213** communicates pressure sensed by pitot tube **212** with nozzle head extension chamber **203**. In chambers **203** and **204**, which are preferably cylindrical in construction, forces acting upon opposing sides of preferably cylindrical piston **202** are measured by pressure times the area of respective surfaces **203a** and **204a**. In a circular piston, a circle defines area **203a** whereas concentric circles define area **204a**. Piston **202**, however, may be non-circular. Thus, the respective velocities of water sensed by the pitot tubes **210** and **212** are translated to opposing forces acting on opposing sides of piston **202**, which is mechanically coupled to or integrally formed with nozzle head **200**.

[0058] A balance in the opposing forces is achieved when the individual products of pressure and area equalize, which drives piston **202**, and consequently nozzle head **200**, to an equilibrium position (e.g., from position indicated by phantom nozzle **201**) thereby providing a mechanism and method to optimize water jet speed for a given boat speed, assuming the operator has knowledge of characteristics of the boat, e.g., optimum hull speed. In mechanical construction, the diameter **d** of neck **205** defines the areas of respective surface **203a** and **204a**, which due to their respective areas automatically effects equilibrium at the appropriate nozzle head position. In the exemplary device, the area of surface **203a** is 1.88 times the area of surface **104a**.

[0059] To automatically control or override the pressure-driven equilibrium position of nozzle head **200**, automated computer control may be implemented to actuate servos according to sensed pressure at pitot tubes **210** and **212**, or conventional transducers and amplifiers may be deployed to produce appropriate control signals to drive a servo or actuator. Instead of using pitot static pressure, the axial position of nozzle **200** in larger propulsion devices may be electrically or hydraulically actuated. In addition, a pressure regulator may be interposed on either or both lines **211**, **213** (or elsewhere) to alter the equilibrium position of or control piston **202**.

[0060] FIGS. 9A through 9D show an exemplary rotor blade design that may be used with the illustrated pumping or propulsion device. Stator vanes may have a similar blade construction, but incorporating a shaft as shown by FIGS. 4 and 5. The illustrative rotor blade of FIGS. 9A and 9B includes a base **300** having a curved head **304** to support blade **302**. According to an aspect of the invention, particularly in connection with the stator vane design, blade **302** has a thin or sharp trailing edge **306** so that an area of the flow path that is normal to fluid flow expands as fluid travels from leading edge **308** to trailing edge **306** of blade **302**. Preferably, blade **302**, head **304**, and base **300** are integrally formed of non-corrosive material, such as stainless or high carbon steel, bronze, or other materials known in the art. In relation to the central rotor axis **13** (FIG. 1), the height of the exemplary blade at equally spaced points A-F from head **304** to the outer tip **310** (FIG. 9C) are 5.93136, 6.67501,

7.41866, 8.162308, 8.905955, and 9.6436023 inches. FIG. 9C shows the relative twist of the exemplary blade and FIG. 9D shows the cross-sectional geometry of the blade from its leading edge **308** to its trailing edge **306**. As known in the art, increasing the radius ratio (i.e., the ratio of blade height to tip radius) decreases blade efficiency. Such losses stem from differential pressures between the root and tip of blade **302**, which result from an increased tip velocity of the blade relative to the working fluid.

[0061] FIG. 10 illustrates exemplary blades and vanes of a three-stage device where working fluid travels in direction **416** through the device upon rotation of the rotor blades in direction **417**. As depicted, the three stages comprise rotor-stator section stages **402-403**, **404-405**, and **406-407**. Only a couple of blades or vanes are shown in each section, which is conceptually represented by cross-cuts at a mean blade or vane height. To simplify the illustration, blade or vane twist is not shown in the illustration.

[0062] The illustration of FIG. 10 includes an optional, variable-pitch inlet guide vane stage **408**, as well as an optional, fixed-pitch exit guide vane stage **410** that straightens the flow of the working fluid prior to discharge. In a preferred structure, it is desired to obtain at each stage a ratio of inlet velocity V_1 to exit velocity V_2 of about 1.15 to 1.50 where

$$V_1/V_2=1.15 \text{ to } 1.0 \quad (5)$$

[0063] Due to a decreasing area of the flow path between the inlet guide vanes **412**, **414** and **418**, which define the respective flow paths, the velocity of the working fluid for a given mass flow rate increases as it flows through section **408**. As seen, the cross-sectional area between inlet guide vanes **412** and **414** decreases in downstream direction **416** because the vane geometry provides a wider width **W1** at its section entry and a narrower width **W2** at its section outlet. The cross-sectional area of the flow path between vanes is measured by width multiplied by vane height, assuming the guide vanes have the same twist angle and constant height throughout the section. As measured in a plane normal to flow path **400**, the area of the flow path between the vanes decreases in the downstream direction. According to an aspect of the invention, the flow path area between the inlet guide vanes can be altered by changing the pitch angle of the inlet guide vanes, as shown by exemplary vane **418**, for example.

[0064] As known in the art, total or absolute pressure of the working fluid in an axial flow device includes two components, i.e., a ram or impact pressure component and a static pressure component. The rotor blades impart ram or impact pressure to the fluid. Static pressure is ambient. Assuming total or absolute pressure remains constant throughout the inlet guide stage, an increase in fluid flow speed after passage through the inlet guide stage **408** necessarily decreases the static pressure component of the working fluid if total pressure is to remain the same. Thus, the variable inlet guide vanes enable altering of pressure and whirl angle of the fluid before entering the first rotor stage. This provides an additional level of control of the performance of the pumping or propulsion device.

[0065] In stages **402-410**, however, the area of the flow passage between rotor blades and stator vane increases from an entry point to an exit point of each section thereby

decreasing the speed of the work fluid as it flows through the pumping or propulsion device. In the succeeding stages **402-410**, the width **W1** at the entry point between rotor blades **422** and **424** is less than the width **W2** at the exit point of these blades—resulting in expanding flow path area when blade height is constant in the direction of axis **13**. Likewise, the width **W1** at the entry point between stator vanes **426** and **428** is less than the width **W2** at the exit point of these vanes—resulting in expanding flow path area when vane height remains constant in the direction of axis **13**. A similar decrease in working fluid velocity occurs in stages **404-410**. Given a constant overall mass flow rate through the pumping or propulsion device, it is seen that the velocity of the working fluid decreases at each section. The decreased velocity over the succeeding stages also lowers internal frictional and eddy (non-laminar) flow losses (which exponentially increases with speed) that are typically encountered in axial flow devices, thus further improving efficiency.

[**0066**] Advantageously, the difference in magnitude of **W1** and **W2**, and consequently the relative entry and exit speeds as well as the extent of whirl of the working fluid when passing the stator section, may be changed by altering the pitch angle of the stator vanes **426** and **428**, as indicated by variable pitch stator blade **430**. Changing the angle of attack of the fluid prior to the rotor stage, i.e., changing the amount of whirl, alters the load placed on the engine, or energy imparted to the fluid. Thus, this aspect of the invention substantially improves the overall operating efficiency at various operating set points of the vessel, or at various engine speeds, torque or power. Although **W1** and **W2** designate entry and exit point width of each section shown in FIG. **10**, these lengths may differ between or among or within the stages or sections without departing from the scope of the invention. Blade or vane twist may also differ among stages, sections, or even within a stage or section. In addition, concentric cylinders substantially, i.e., the internal wall of the outer casing and the exterior surface of the rotor blade wheel, define the illustrated annular chamber of the pumping or propulsion device but other geometries may also be employed to define a suitable flow path.

[**0067**] The exit guide vanes **440**, **442**, and **442** serve to straighten fluid flow at the discharge nozzle. Their pitch angle may be fixed or variable. A mechanism similar to that use to vary the stator vanes may be employed to vary the pitch angle of the exit guide vanes. This provides an additional layer of control.

[**0068**] As apparent, the invention allows control of thrust either by controlling mass flow via inlet guide vane position, by altering the pitch of the stator vanes (in the variable pitch embodiment of the invention) and thus the pressure imparted to the fluid by each rotor section, by altering the discharge nozzle area or jet velocity to optimally match boat and water jet speed, or any combination thereof, for any given horsepower, torque, or drive speed applied to a multistage axial flow pump or propulsion device. Since it is desired to operate most turbine or piston engines (diesel or gasoline) at an maximum power, at maximum fuel efficiency, at an optimum constant engine speed for best hull speed or sea state condition, or on an optimum performance curve, inlet guide vane throttling (to control mass flow) and/or discharge jet velocity may advantageously be adjusted at the will or desire of the shipmaster to meet any varied performance characteristics of the vessel. The inlet guide vanes may be

configured to rotate plus or minus thirty degrees, more or less, from a neutral position. This way, mass flow is positively controlled independent of the speed of the vessel.

[**0069**] For a long haul, the shipmaster may desire to operate on a best speed-range curve to travel the known distance in the shortest time. In other situations, the shipmaster may desire to travel the farthest distance given the amount of fuel onboard. In yet other situations, the shipmaster may desire to travel at the highest speed given the available horsepower, sea state condition, loading of the vessel, and/or design speed of the hull. The present invention meets all of these demands.

Dual-Flow Propulsion System

[**0070**] FIGS. **11A** and **11B** show an alternative embodiment of the invention that comprises a dual-flow propulsion system and method where a multistage high pressure section **500** and a multistage low pressure “booster” section **502**, with a certain sacrifice in weight-power or weight-volume density, cooperatively provide even a greater range of efficient vessel operability, including efficient operation at low to moderate vessel speeds. As indicated herein, a single-flow multistage propulsor having only a high pressure section provides greater efficiencies, typically 20-30% greater, over prior art propulsors at higher speeds, e.g., above fifty to sixty knots. In combination with a low pressure booster section, however, similar efficiencies and improved performance can also be achieved at lower speeds, e.g., between twenty and fifty knots.

[**0071**] Booster section **502** enables higher flow rates to attain a higher propulsive efficiency and greater acceleration with minimal impeller cavitation. In a typical installation, both sections of the dual-flow system are mounted inside the hull of a vessel above to water line for easy access and maintenance. A diffuser duct is typically used to channel water from the bottom of the hull, and such a diffuser duct may be used to channel water to the inlet of low pressure section **502**. As vessel speed increases, a series of nozzles disposed about a periphery **504** of the booster section may be partially or completely closed, either gradually or stepwise, using a conventional mechanism, in order to control water flow towards the inlet guide vanes of high pressure section **500**, explained above. In one embodiment, the extent of nozzle opening (or closure) may be control by rotating slip ring **515** clockwise or counter-clockwise, as illustrated in FIG. **11B**. Conventional pressure sensors and servo controllers may also be employed to control the nozzles **510** to maintain a constant pressure (e.g., equal to a pressure differential between two stages of the high pressure section **500**), the highest pressure possible, or other regulated pressure at the input stage (inlet guide vane) of the high pressure section **500** (depending on design parameters and desired performance). Generally, nozzle opening (or closure) in the booster section is controlled to minimize cavitation in the high pressure section by controlling (e.g., maximizing) the first stage inlet pressure, particularly when a high torque is applied to the propulsor at a low or zero vessel speed, and/or to remove any residual drag induced by the larger low pressure section at moderate to higher vessel speeds, e.g., by discharging excess water flow not taken by the high pressure section. To achieve the stated goals, nozzle control may be effected according to speed or desired mass flow of fluid in either of the respective high or low pressure

sections, rotational speed(s) of the drive shaft(s) in the respective high and low pressure sections, relation between vessel speed and mass flow within the propulsor, or in accordance with the state of other parameters of the vessel or propulsor.

[0072] At lower vessel speeds, nozzles **510** remain open to provide additional thrust around the periphery of the housing of high pressure section **500**. Total thrust produced by the embodiment of FIG. **11A** is the combination of the respective thrusts of the high and low pressure sections **500** and **502**. In the illustrated embodiment, booster section **502** includes a set of inlet guide vanes **511** (only one shown) that is fixed internally of housing **512** to control the angle of attack, e.g., swirl angle, of incoming fluid as it impinges upon a first stage of the booster section. As shown, booster section **502** includes two rotor sections **530**, **531** (only one rotor blade **520**, **521** is shown in each section) and one peripheral stator section (only one stator vane **523** is shown) fixed to the inside of housing **512**. The low pressure section is not limited to the structure shown, but may have any number of stages, e.g., any number rotor or stator sections. In certain cases, it may also be desirable to provide variable pitch mechanism for booster section stator vanes like that provided above for variable pitch stator vanes of high pressure section **500**. A series of peripherally mounted struts **525** maintain the relative positioning of the high and low pressure sections **500** and **502**. Each section **500** or **502** is preferably driven by a common drive shaft but may also be separately driven by respective engines. If driven by a common rotor shaft, an optional gearing mechanism may be interposed to provide different rotational speeds for the high and low pressure sections. Relative speeds of the high and low pressure section are, in part, dictated by the blade-vane parameters including their angle of attack relative to incoming fluid, such as depicted in exemplary designs listed in Tables 1-6 set forth in the appendix. Such design parameters, though, are not intended to limit the invention. In the tables, "Ww" indicates water flow, "dp" means differential pressure, "HP" means high pressure (unless associated with "horse power"), "LP" means low pressure, and "so" indicates speed. Radius ratio means the ratio of the blade/vane height to the radius of the tip of rotation. Tip diameter ratio refers to the tip diameter of the booster section to the tip diameter of the high pressure section. Other terms are self-explanatory.

Split-Casing Construction

[0073] FIGS. **12A-12C** show yet a further embodiment of the invention that may be particularly useful for smaller power plants in the range of 200 to 2000 horse power range. Conventional axial flow pumps are generally designed for an engine having a given horsepower or a fixed engine set point, and thus can only be efficiently operated within a small range (e.g., plus or minus 5-10%) of power input. To accommodate different engines, the manufacturer had to provide a separate pump for each engine size or power, which became relatively costly in terms of tooling costs, service, replacement parts, etc. According to this additional aspect of the invention, multiple stator vane ensembles are

provided to adapt a given pump to wider power input ranges—much like that provided by variable pitch stators and inlet guide vanes described above. It is envisioned that a given multistage pump design, for example, can be adapted to input power that varies by a factor of two to three, more or less. Using a factor two, a standard 400 horsepower pump may easily be reconfigured for a larger engine up to 800 horse power, or reconfigured for a smaller engine of at least 200 horsepower. Such flexibility aids the manufacturer as well as a vessel owner desiring an engine upgrade.

[0074] To implement such embodiment, FIG. **12A** shows a split-casing design of an exemplary pump having an inlet guide section and mating top and bottom sections **604** and **606** that house the multistage sections that include both rotor and stator sections. FIG. **12B** show further details of a mating section **604** or **606** (preferable but not necessarily identical) having channels or slots **608**, **610**, and **612** to receive top and bottom stator ring ensembles **620** and **622** shown in FIG. **12C**. The split-casing design also enables convenient access and maintenance of the pump at sea without the necessity port maintenance.

[0075] FIG. **13A**, from a view looking downstream of fluid flow, shows a partial cut-a-way section of stator ring assembly mounted in the interior wall of casing half **604**. As shown, the stator ring assembly comprises an outer shroud **621** and an inner shroud **622** that having a series of fixed-pitch stator vanes **623-627** sandwiched therebetween. The rotor section (not shown here) is fixed to a shaft that rotates within the housing **604**, **606**. As a matter of reference, vane **625** has a leading edge **625'** and a trailing edge **625''**, and may be geometrically shaped like the blades or vanes illustrated in FIGS. **9A-9D**. The outer shroud **621** is geometrically shaped to be inserted, by circumferentially sliding action, into slots **608-612** (FIG. **12B**) of casing **604**. FIG. **13B** shows a plan view of ring ensemble **620** inserted in slot **610** of casing half **604**. Also shown are a series of bolt holes **631-634** used to fasten together the split casings **604** and **606**. FIG. **13C** shows a stator vane **625**, for example, sandwiched between inner and outer shrouds **621** and **622** of the stator vane ensemble **620**. When set into the ensemble, the pitch angle of vane **625** is adjusted to configure the pump to receive a given input power. The stator vanes may be affixed to the inner and outer shrouds by a furnace brazing process. By adjusting the pitch angle of the vanes in different sets of ring ensembles, a given pump design may be adapted to handle multiple horsepower settings within a given, relatively wide range defined by the combination of the stator and impeller sections.

[0076] Tables in the appendix proposed design parameters of exemplary propulsors having both a low-pressure booster section and a high-pressure primary section.

Inlet Diffuser for Ram Pressure Recovery

[0077] FIGS. **14A**, **14B**, and **15** illustrate an inlet diffuser or duct design that also takes advantage of the stator vane aspects of the present invention. This aspect of the invention may be applied to axial or mixed-flow pump jets, or to

centrifugal pumps with proper ducting. The purpose of a diffuser is to convert the maximum amount of ram pressure resulting from vessel speed to hydrostatic pressure as the fluid arrives at the pump jet inlet. In the case where inlet ram pressure is taken directly from the upstream direction (rather than from the bottom of a hull), inlet pressure attributable to vessel speed in psi (pounds per square inch) equals $(\frac{1}{2} \rho V^2)/(2g \cdot 144)$, where ρ is the density of water (64.2 lbs/ft³), g is the gravity acceleration constant, and V is the velocity of the vessel in feet per second. When the propulsor inlet lies below the water's surface, additional static pressure is added. At one hundred and two miles per hour, for example, ram pressure equals 78.0 psi, which represents the initial pressure available to the pump jet propulsion system.

[0078] A diffuser that might be adapted to an inlet duct might have a diffuser ratio of 0.666 (i.e., ratio of inlet to outlet cross-sectional area of the diffuser), which would recover 51.9 psi of 78.0 psi of ram pressure. Such a diffuser having a maximum allowable divergent angle between 6° and 11°, i.e., the angle from a central axis of diverging walls of the diffuser, may be unduly long in the axial direction, as indicated by the length of duct 702 extending behind vessel 706 of FIG. 14A. The diffuser housing may have a rectangular, square, or circular cross-sectional shape in a downstream direction.

[0079] To explain further, FIG. 14A shows an inlet duct 702 mounted near the transom 704 on a planing hull of vessel 706. In the downstream direction, the cross-sectional area of duct 702 increases from an opening 708 to the pump intake 710. In an exemplary construction, the cross-sectional area is ten square inches looking into the opening 708, as shown in FIG. 14B, where the opening 708 measures one inch in height and ten inches across. In a planing hull of a high speed vessel, it is desirable to provide an intake that is a rather narrow in the vertical direction at the aft edge of the planing surface. In a displacement hull, the intake may be positioned practically at any location below the water surface. The initial cross-sectional area at the opening 708 expands to about one hundred square inches at the pump intake 710—accounting for an area consumed by the pump draft shaft 712. Advantageously, this provides an inlet to outlet ratio of about 10:1.

[0080] According to further refined aspect of the present invention, the diffuser duct may be staggered in multiple, stepped stages, as shown in FIG. 15, in order to recover more of the ram pressure of the incoming fluid in a shorter downstream direction. In the illustrative ram recovery apparatus of FIG. 15, diffuser 720 has a ram inlet 722 having a first inlet area, and an outlet 724 having a significantly larger discharge area. Outlet 724 discharges working fluid into a multistage propulsion device, such as the pump described herein. In a stepwise manner, working fluid is re-directed, e.g., approximately 30° (more or less), and the cross-sectional area in the diffuser is stepwise increased in the downstream direction. A series of deflector vane groups 726, 727, and 728 are provided to re-direct the working fluid at each section of the diffuser. Although re-direction is illustrated in the upward direction, it may occur in any direction. This aspect of the invention, though, is not limited to the

specific illustration or redirection angle, but include all constructions or method that involve re-direction of working fluid to shorten the forward-to-aft-distance of the diffuser. Shortening such distance is important when the diffuser inlet lies at the aft end of a planing hull, as shown in FIG. 14A, to permit positioning of the propulsor unit near the transom. In the case where incoming fluid is taken from the bottom of hull, a stepped diffuser may still provide benefits due to for-to-aft flow velocity of water, although not to the same extent as a direct ram intake.

[0081] In the illustrated diffuser, each set of vane groups 726, 727, and 728 may recover as much as $1/\cos \theta$ of the ram pressure (assuming θ is about 30°) preceding the respective group. The deflection angle, however, may range between a few degrees to less than ninety degrees. In certain circumstances, it may also be practicable to deflect flow up to 180° provided the net gain in efficiency exceeds duct losses. A diffuser having four sets of deflector groups, for example, would yield a recovery ratio of 1.8:1, or a total ram pressure recovery 0.77 instead of 0.666 using a longer diffuser without deflectors. Additional diffuser sections having additional stator vane groups may be incorporated to further increase ram recovery of a multi-section diffuser. Similar to the fixed stator vanes of the multistage propulsor described herein, the vanes of deflector groups 726, 727, and 728 are designed to increase the cross-sectional area of fluid flow in the downstream direction in order to convert ram pressure to static pressure. In one embodiment, this is accomplished by providing deflector vanes having an airfoil shape, like that illustrated by an airfoil of FIG. 10. The individual vanes in groups 726-728, however, need not have a twist angle (like those of blades illustrated in FIGS. 9A-9C) since they are not mounted for rotation on a shaft but, instead, may be specifically configured according to diffuser duct geometry. If, according to the teachings herein, there is provided a deflector vane and duct design that yields a 90% recovery ratio, ram recovery amounts to 70.2 psi (pounds per square inch) instead of 51.9 psi of a conventional design having 66.6% ram recovery, thereby yielding an additional 18.3 psi in static pressure prior to fluid entry into the propulsor pump. This additional pressure may be used to lessen the amount of horsepower required to maintain a given vessel speed, or to provide increased vessel speed using the same horse power. In the example given herein, a 90% ram recovery equates to an additional 6.7% in fuel savings over and above that provided by the multistage propulsor design and/or the dual flow propulsor design, described above (less frictional losses induced by the deflector vanes and stepped diffuser). Such savings become extremely desirable in large, high-speed ocean vessels powered by 100,000 horsepower or more, such as modern day fast ferries and cargo ships.

[0082] Embodiments of the invention may be used to propel displacement or hydroplaning hulls, or in hydrofoil or submarine applications. The invention may also be deployed in water or fluid pumping applications to pump the greatest amount of water or other fluid at the highest pressure for a given horsepower input, or to control the amount of water or other fluid delivered by a pumping station. Thus, the invention embraces all such modifications and adaptations that may come to those skilled in the art in view of the teachings herein.

APPENDIX

[0083]

TABLE 1

Density Sea Water	84.2	Radius ratio LP	0.5
Density Fresh Water	62.4	Radius ratio HP	0.866
One HP (Ft Lbs/Sec)	550	Tip Dia Ratiio	1.76 Tip Dia Booster/Tip Dia Hi Pressure
g Accel Of Gravity	32.17	Tip Dia HP	9 inches
LP Inlet flow coeff	0.98	Tip Dia LP	15.75 inches
HP Inlet flow coeff	0.99	HP blade height	1.503
LP Noz dp psi @	40	LP blade height	3.9375
RPM@	2500	HP inlet area	19.47399
LP Pitch Dia	11.8125 inches	LP inlet area	85.23738
LP Pitch Sp (in/sec)	1548.256	Num stgs LP	2
Ww (Total)	1100865 in cu/sec	Num stgs HP	4
Ww (Total) Lbs/sec	40900.21	Ram recovery Coeff	0.8
Ww net	40082.2	Eff HP	0.9
HP Pitch Dia	7.497	Eff LP	0.92
HP Pitch Speed	981.3573	HP req'd LP	6064.054 (horse power)
Ww(HP) Total	101309.5 in cu/sec	HP req'd HP	3126.958 (horse power)
Ww(HP) Lbs/sec	3726.292 net	Total HP req'd	9191-012 (horse power)
LP Flow (net)	37173.91 lbs/sec	TOTAL THRUST	107.474 LBS
LP Noz Vel	75.97737 ft/sec		
LP Thrust	87785.34 Lbs		
Hp Noz dp	200 psi		
Hp Noz vel	169.8906 ft/sec		
Hp Thrust	19678.64 Lbs		

[0084]

TABLE 2

Data			
Density Sea Water	64.2	Radius ratio LP@	0.5
Density Fresh Water	62.4	Radius ratio HP @	0.666
One HP (Ft Lbs/sec)	550	Tip Dia Ratio @	1.5
g Accel of Gravity	32.17	Tip Dia Hi Pressure	9 inches
LP Inlet flow coeff	0.98	Tip Dia LP	13.5 inches
HP Inlet flow coeff	0.99	HP blade height	1.503
LP Noz dp psi @	40	LP blade height	3.375
RPM @	2500	HP inlet area	19.47399
LP Pitch Dia	10.125 inches	LP inlet area	62.62338
LP Pitch Sp (in/sec)	1325.363	Num stgs LP	2
Ww (Total)	594219.7 in cu/sec	Num stgs HP	4
Ww (Total) Lbs/sec	22076.91	Ram recovery Coeff	0.8
Ww net	21635.37	Eff HP	0.9
HP Pitch Dia	7.497	Eff LP	0.92
HP Pitch Speed	981.3573	HP req'd LP	2993.474 (horse power)
Ww(HP) Total	101309.5 in cu/sec	HP req'd HP	3126.958 (horse power)
Ww(HP) Lbs/sec	3726.292 net	Total HP req'd	6120.432 (horse power)
LP Flow (net)	18350.62 lbs/sec	TOTAL THRUST	63018.14 LBS
LP Noz Vel	75.97737 ft/sec		
LP Thrust	43339.51 Lbs		
Hp Noz dp	200 psi		
Hp Noz vel	169.8906 ft/sec		
Hp Thrust	19678.64 Lbs		

[0085]

TABLE 3

Data			
Density Sea Water		Radius ratio LP@	0.5
Density Fresh Water		Radius ratio HP @	0.666
One HP (Ft Lbs/Sec)		Tip Dia Ratio @	1.76
g Accel of Gravity		Tip Dia Hi Pressure	9 inches
LP Inlet flow coeff		Tip Dia LP	15.75 inches

TABLE 3-continued

Data			
HP Inlet flow coeff		HP blade height	1.503
LP Noz dp psi @		LP blade height	3.9375
RPM@	1500	HP inlet area	19.47399
LP Pitch Dia	11.8125 inches	LP inlet area	85.23738
LP Pitch Sp (In/sec)	927.7538	Num stgs LP	2
Ww (Total)	660519.2 in cu/sec	Num stgs HP	4
Ww (Total) lbs/sec	24540.12	Ram recovery Coeff	0.8
Ww net	24049.32	Eff HP	0.9
HP Pitch Dia	7.497	Eff LP	0.92
HP Pitch Speed	588.8144	HP req'd LP	3638.432 (horse power)
Ww(HP) Total	60785.73	HP req'd HP	1876.175 (horse power)
Ww{HP} Lbs/sec	2235.775 net	Total HP req'd	5514.807 (horse power)
LP Flow (net)	22304.35 lbs/sec	TOTAL THRUST	64484.39 LBS
LP Noz Vel	75.97737 ft/sec		
LP Thrust	52677.21 Lbs		
Hp Noz dp	200 psi		
Hp Noz vel	169.8906 ft/sec		
Hp Thrust	11807.18 Lbs		

[0086]

TABLE 4

Data			
Density Sea Water	64.2	Radius ratio LP@	0.66
Density Fresh Water	62.4	Radius ratio HP @	0.666
One HP (Ft Lbs/Sec)	550	Tip Dia Ratio @	1.75
g Accel of Gravity	32.17	Tip Dia Hi Pressure	9 inches
LP Inlet flow coeff	0.98	Tip Dia HP	15.75 inches
HP Inlet flow coeff	0.99	HP blade height	1.503
LP Noz dp psi @	40	LP blade height	2.63025
RPM @	1500	HP inlet area	19.47399
LP Pitch Dia	13.11975 inches	LP inlet area	59.63908
LP Pitch Sp (in/sec)	1030.425	Num Stgs LP	2
Ww (Total)	570103.6 in cu/sec	Num Stgs HP	4
Ww (Total) Lbs/sec	21180.93	Ram recovery Coeff	0.8
Ww net	20757.31	Eff HP	0.9
HP Pitch Dia	7.497	Eff LP	0.92
HP Pitch Speed	588.8144	HP req'd LP	3090.459 (horse power)
Ww(HP) Total	60785.73 in cu/sec	HP req'd HP	1876.175 (horse power)
Ww{HP} Lbs/sec	2235.775 net	Total HP req'd	4966.634 (horse power)
LP Flow (net)	18945.16 lbs/sec	TOTAL THRUST	56550.84 LBS
LP Noz Vel	75.97737 ft/sec		
LP Thrust	44743.65 lbs		
Hp Noz dp	200 psi		
Hp Noz vel	169.8906 ft/sec		
Hp Thrust	11807.18 lbs		

[0087]

TABLE 5

Data			
Density Sea Water	64.2	Radius ratio LP@	0.5
Density Fresh Water	62.4	Radius ratio HP @	0.666
One HP (Ft Lbs/Sec)	550	Tip Dia Ratio @	1.75
g Accel of Gravity	32.17	Tip Dia Hi Pressure	9 inches
LP Inlet flow coeff	0.98	Tip Dia HP	15.75 inches
HP Inlet flow coeff	0.99	HP blade height	1.503
LP Noz dp psi @	50	LP blade height	3.9375
RPM@	2500	HP inlet area	19.47399
LP Pitch Dia	11.8125 inches	LP Inlet area	85.23738
LP Pitch Sp (in/sec)	1546.256	Num stgs LP	2
Ww (Total)	1100865 in cu/sec	Num stgs HP	4
WW (Total) Lbs/sec,	40900.21	Ram recovery Coeff	0.8

TABLE 5-continued

Data			
Ww net	40082.2	Eff HP	0.9
HP Pitch Dia	7.497	Eff LP	0.92
HP Pitch Speed	981.3573	HP req'd LP	7580.067 (horse power)
Ww(HP) Total	101309.5 in cu/sec	HP req'd HP	3908.698 (horse power)
Ww(HP) Lbs/sec LP	3726.292 net	Total HP req'd	11488.76 (horse power)
Flow (net)	37173.91 lbs/sec	TOTAL THRUST	120159.6 lbs
LP Noz Vel	84.94528 ft/sec		
LP Thrust	98158.18 Lbs		
Hp Noz dp	250		
Hp Noz vel	189.9434 ft/sec		
Hp Thrust	22001.39 Lbs		

[0088]

TABLE 6

Data			
Density Sea Water	84.2	Radius Ratio Booster r	0.5
Density Fresh Water	62.4	Radius Ratio Hi Press	0.666
One HP (Ft Lbs/sec)	550	Tip Dia Ratio (TDR)	1.5 Tip Dia Booster/Tip Dia Hi Pressure
g Accel of Gravity	32.17	Tip Dia Hi Pressure	9 inches
LP Inlet flow coeff	0.98	Tip Dia Booster	13.5 inches
HP Inlet flow coeff	0.99	HP blade height	1.503
LP Noz dp psi	40	LP blade height	3.375
RPM	2500	HP inlet area	19.47399
LP Pitch Dia	10.125 inches	LP inlet area	62.62338
LP Pitch Sp (in/sec)	1325.363	Num stgs LP	2
Ww (Total)	594219.7 in cu/sec	Num stgs HP	4
Ww (total) lbs/sec	22076.91	Ram recovery Coeff	0.8
Ww net	21635.37	Eff HP	0.9
HP Pitch Dia	7.497	Eff LP	0.92
HP Pitch Speed	981.3673	HP req'd LP	2993.474 (horse power)
Ww(HP) Total	101309.5 in cu/sec	HP req'd HP	3126.958 (horse power)
Ww(HP) Lbs/sec	3726.292 net	TOTAL THRUST	63018.14 lbs
LP Flow (net)	18350.62 lbs/sec		
LP Noz Vel	75.97737 ft/sec		
LP Thrust	43339.51 lbs/sec		
Hp Noz dp	200		
Hp Noz vel	169.8908 ft/sec		
Hp Thrust	19678.64 lbs/sec		

1. A multistage axial flow pumping device comprising:
a housing,
a longitudinal chamber within the housing to convey a working fluid from an inlet to an outlet, said chamber including at least two rotor stages that each include a rotor section, said chamber further including a stator section between respective rotor sections,
said rotor section including a multi-bladed drive wheel positioned downstream of said inlet and operative to rotate around an axis to thereby to pump working fluid from the inlet to the outlet through a high pressure section defined within said chamber, and
said stator section being positioned downstream of a rotor section and including plural stator vanes substantially fixed relative to said housing and geometrically arranged to define a flow path having a cross-sectional area between vanes that increases from an entry point to an exit point of the stator section.

2. The device of claim 1, wherein said stator vanes are variable in pitch to adjust the angle of attack of the working fluid upon entry into a following rotor section.

3. The device according to claim 1, wherein said outlet comprises a convergent annular chamber at a discharge nozzle whereby to increase velocity of liquid discharged from said outlet.

4. The device of claim 3, wherein said convergent annular chamber includes a variable throat area positioned immediately upstream of said outlet to vary the velocity of the liquid discharged from said outlet.

5. The device of claim 4, further including an actuator to vary the axial position of a nozzle plug whereby to vary effective area of said outlet.

6. The device of claim 4, further including balancing pistons operated by pressure differentials obtained by sensing discharge nozzle jet velocity and vessel velocity respectively to obtain a desired optimum discharge velocity relative to vehicle velocity.

7. The device of claim 6, further including a nozzle plug position override effective to reposition said nozzle plug by overriding automatic positioning of said balancing pistons with hydraulic pressure.

8. The device of claim 1, further including at least one variable inlet guide vane positioned downstream of said inlet and operative to adjust the whirl angle of fluid entering said inlet.

9. The device of claim 1, further comprising a fixed set of inlet guide vanes positioned downstream of said inlet to adjust inlet whirl angle of liquid entering said inlet.

10. The device of claim 9, further comprising an inlet diffuser serving as an inlet duct positioned upstream of said inlet guide vanes.

11. The axial flow pumping device of claim 1, further comprising a larger diameter booster section preceding the high pressure section and operative to increase fluid pressure at said inlet.

12. The axial flow pumping device of claim 11, wherein said booster section comprises multiple rotor stages, said booster section further including a stator section between respective rotor sections.

13. The axial flow pumping device of claim 11, wherein said booster section includes variable discharge nozzles and an actuator to control the discharge nozzles to maintain a given pressure at the inlet of the high pressure section.

14. The axial flow pumping device of claim 11, wherein said booster section further includes variable pitch stator vanes.

15. The axial flow pumping device of claim 11, further comprising a common drive shaft for said pumping device and said booster section.

16. The axial flow pumping device of claim 11, wherein said booster section includes a set of inlet guide vanes to control the whirl angle of incoming fluid.

17. The axial flow pumping device of claim 1, wherein said longitudinal chamber has a cross-sectional area that initially decreases in a downstream direction and that subsequently increases upstream of said outlet to form an expansion region prior to discharge of the working fluid whereby to convert ram pressure of higher speed working fluid to static pressure in lower speed working fluid in order to reduce internal friction within said longitudinal chamber and to improve propulsive efficiency of said pumping device.

18. The axial flow pumping device of claim 17, wherein said longitudinal chamber is annular.

19. The axial flow pumping device of claim 18, wherein rotor and stator vanes of successive stages in the chamber have decreasing heights in the downstream direction and rotor blade drive wheels have corresponding increasing diameters in the downstream direction.

20. The axial flow pumping device of claim 18, wherein rotor and stator vanes of successive stages in the chamber have decreasing heights and the housing diameter decreases in the downstream direction to attain a decreasing effective area of the annular chamber in the downstream direction.

21. The axial flow pumping device of claim 18, wherein rotor and stator vanes of successive stages in the chamber have increasing heights in the downstream direction and rotor blade drive wheels have corresponding decreasing diameters in the downstream direction.

22. The axial flow pumping device of claim 18, wherein rotor and stator vanes of successive stages in the chamber have increasing heights and the housing diameter increases in the downstream direction to attain an increasing effective area of the annular chamber in the downstream direction.

23. A method of conveying a working fluid through an axial flow pumping device comprising:

defining a flow path in the axial flow pumping device to convey the working fluid from an inlet to an outlet,

providing multiple stages within said flow path that each include a rotor section,

providing at least one stator section between at least two rotor sections,

driving working fluid through said flow path by rotating the rotor section, and

lowering the speed of working fluid in said path by providing increased flow path areas between vanes of the stator section as the working fluid travels in the downstream direction.

24. The method of claim 23 wherein said inlet includes variable inlet guide vanes having controllable pitch and said method further including controlling the whirl angle at said inlet by altering the pitch of said inlet guide vanes.

25. The method of claim 23 wherein said outlet includes an exit guide vane stage operative to straighten flow of said working fluid and to increase static pressure prior to discharge.

26. The method of claim 23, further including boosting pressure of said working fluid prior to conveying the working fluid from the inlet to the outlet.

27. The method of claim 23, further comprising oppositely altering ram and static pressure of the working fluid by varying the cross-sectional area of the flow path in the downstream direction whereby to reduce internal friction and improve propulsive efficiency.

28. A method of controlling discharge velocity of water discharged from an axial flow pumping device relative to water speed a vessel, said method comprising:

detecting discharge velocity of water discharged from the axial flow device,

detecting water speed of the vessel,

providing a discharge nozzle in said axial flow device having a variable area throat, and

utilizing said discharge velocity and boat velocity to control the area of said throat according to a desired set point based on the discharge velocity of the water and the speed of the vessel.

29. The method of claim 28, further comprising providing an actuator that drives the discharge nozzle, said detecting steps includes detecting respective pressures associated with said discharge velocity and water speed of the vessel, and said utilizing step includes using the respective pressures to drive said actuator to an equilibrium position that defines a desired optimum throat area of the discharge nozzle.

30. A dual flow axial flow liquid pumping device comprising:

a low pressure section that conveys liquid along a downstream path in a chamber having a first cross-sectional area,

a high pressure section in communication with the low pressure section that conveys said liquid along a downstream path in a chamber having a second cross-sectional area that is smaller than said first cross-sectional area, and

said first and second sections each having at least one rotor-stator stage mounted on respective shafts that drive the respective stages to stepwise pressurize the liquid in the respective sections.

31. The dual flow axial flow liquid pumping device of claim 30, wherein at least one of said high and low pressure sections includes a set of stationary vanes operative to increase static pressure between said at least one rotor-stator stage of a section by converting ram pressure of the liquid to static pressure.

32. The dual flow axial flow liquid pumping device of claim 31, wherein said low pressure and high pressure sections have concentric annular chambers in communication with each other and said low pressure section includes control nozzles that control discharge of liquid around the annular chamber of said high pressure section.

33. The dual flow axial flow liquid pumping device of claim 32, wherein said respective shafts are common.

34. The dual flow axial flow liquid pumping device of claim 32, wherein said respective shaft are geared together to provide different rotational speeds of the respective shafts.

35. A dual flow pumping method that pumps water during water jet propulsion, said method comprising:

pressurizing the water at a first lower pressure,

conveying the water along a first downstream path having a first cross-sectional area,

utilizing the first lower pressure of the water to establish a higher pressure in said water along a second downstream path having second cross-sectional area that is smaller than said first cross-sectional area,

providing at least one rotor-stator stage in each of said first and second downstream paths in order to stepwise pressurize the water in each path, and

powering said rotor stator stages in each path to propel a vessel by water jet propulsion.

36. An water jet propulsion device comprising:

a propulsion pump; and

a diffuser preceding said propulsion pump, said diffuser including an inlet, a larger outlet in communication with said propulsion pump, multiple sections between said inlet and outlet that have increasing cross-sectional area in the downstream direction, and multiple groups of deflector vanes between said sections that re-direct and convert ram pressure of the liquid to static pressure between respective sections.

37. The propulsion device of claim 36, wherein said deflector vanes are positioned between respective sections to re-direct said liquid approximately 30° from a nominal flow direction of a preceding section.

* * * * *