



US00D718711S

(12) **United States Design Patent**
Rabalais et al.

(10) **Patent No.:** **US D718,711 S**

(45) **Date of Patent:** **** Dec. 2, 2014**

(54) **BATTERY CHARGER**

(71) Applicant: **The Gillette Company**, Boston, MA (US)

(72) Inventors: **Brian Adam Rabalais**, New Milford, CT (US); **Eric Justin Price**, Wilton, CT (US); **Francisco Jose Restrepo**, Norwalk, CT (US); **Chen Jian**, ShenZhen (CN); **Zhang Yun**, ShenZhen (CN); **Paul Edward Beckett**, Portland, OR (US); **David John Saylor**, Portland, OR (US); **Chunshik Kim**, Portland, OR (US)

(73) Assignee: **The Gillette Company**, Boston, MA (US)

(**) Term: **14 Years**

(21) Appl. No.: **29/466,830**

(22) Filed: **Sep. 12, 2013**

(51) **LOC (10) Cl.** **13-02**

(52) **U.S. Cl.**
USPC **D13/107**

(58) **Field of Classification Search**
USPC D13/107-110, 118-119, 184, 199;
D14/251, 253, 432, 434; 320/107-115,
320/128, 137-140

See application file for complete search history.

(56) **References Cited**

U.S. PATENT DOCUMENTS

D278,702 S 5/1985 Chiodo et al.
D278,703 S * 5/1985 Chiodo et al. D13/107

(Continued)

OTHER PUBLICATIONS

U.S. Appl. No. 29/466,827, filed Sep. 12, 2013, Brian A. Rabalais et al.

(Continued)

Primary Examiner — Rosemary K Tarcza

(74) *Attorney, Agent, or Firm* — Leo J. White; Kevin C. Johnson; Steven W. Miller

(57) **CLAIM**

The ornamental design for a battery charger, as shown and described above.

DESCRIPTION

FIG. 1 is a top perspective view of a design for a battery charger of the present invention; FIG. 2 is a front side view thereof; FIG. 3 is a back side view thereof; FIG. 4 is a right view thereof; FIG. 5 is a left view thereof; FIG. 6 is a top view thereof; FIG. 7 is a bottom view thereof; FIG. 8 is a bottom perspective view thereof; FIG. 9 is a top perspective view of another design for a battery charger of the present invention shown in the open position; FIG. 10 is a front side view of the battery charger shown in the open position; FIG. 11 is a back side view of the battery charger shown in the open position; FIG. 12 is a right view of the battery charger shown in the open position; FIG. 13 is a left view of the battery charger shown in the open position; FIG. 14 is a top view of the battery charger shown in the open position; FIG. 15 is a bottom view of the battery charger shown in the open position; and, FIG. 16 is a bottom perspective view of the battery charger shown in the open position. The broken lines shown in the drawings are included for the purpose of illustrating environmental structure and form no part of the claimed design.

1 Claim, 14 Drawing Sheets

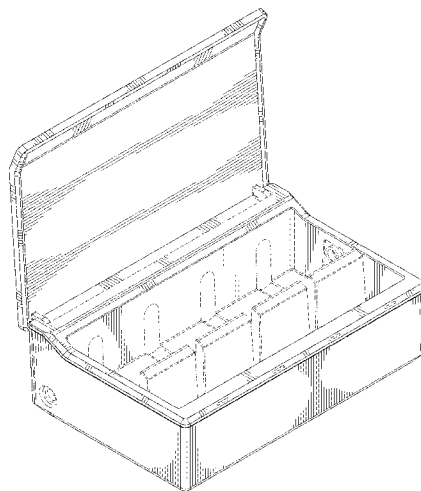
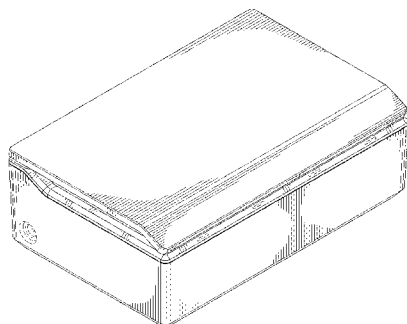

(56)

References Cited

U.S. PATENT DOCUMENTS

D331,220 S 11/1992 Tsuchiya
 D336,281 S 6/1993 Nakamura et al.
 D358,363 S * 5/1995 Usami D13/107
 D375,934 S 11/1996 Rosen et al.
 5,686,811 A * 11/1997 Bushong et al. 320/110
 D412,487 S 8/1999 Nagele et al.
 D442,544 S 5/2001 Ku
 D443,856 S 6/2001 Lehtovaara
 D454,837 S 3/2002 Ibuki et al.
 D478,557 S * 8/2003 Pfeiffer D13/107
 D515,501 S 2/2006 Kawasaki
 D532,370 S 11/2006 Shimizu
 D546,281 S 7/2007 Bell
 D548,178 S 8/2007 Suk et al.
 D552,029 S * 10/2007 Kingston et al. D13/108
 D552,539 S * 10/2007 Choi et al. D13/108

D553,077 S * 10/2007 Kim et al. D13/108
 D564,960 S 3/2008 Sacco et al.
 D565,506 S 4/2008 Sacco et al.
 D626,916 S * 11/2010 Hine D13/107
 D650,327 S * 12/2011 Kingston D13/107
 D654,017 S * 2/2012 Lentine D13/107
 D675,622 S * 2/2013 Petrick et al. D14/434
 D701,830 S * 4/2014 Edwards D13/107
 2002/0063550 A1 5/2002 Chen et al.
 2004/0108832 A1 6/2004 Hsiao
 2004/0130289 A1 7/2004 Lam et al.
 2007/0188130 A1 * 8/2007 Scheucher 320/110

OTHER PUBLICATIONS

U.S. Appl. No. 29/466,829, filed Sep. 12, 2013, Brian A. Rabalais et al.

* cited by examiner

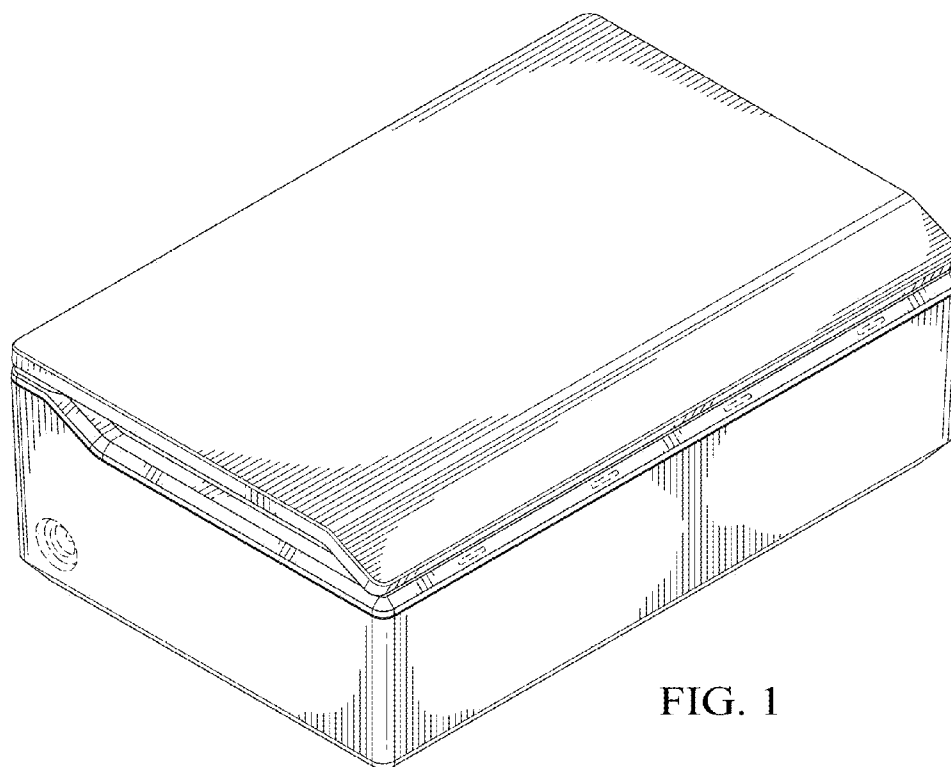

FIG. 2

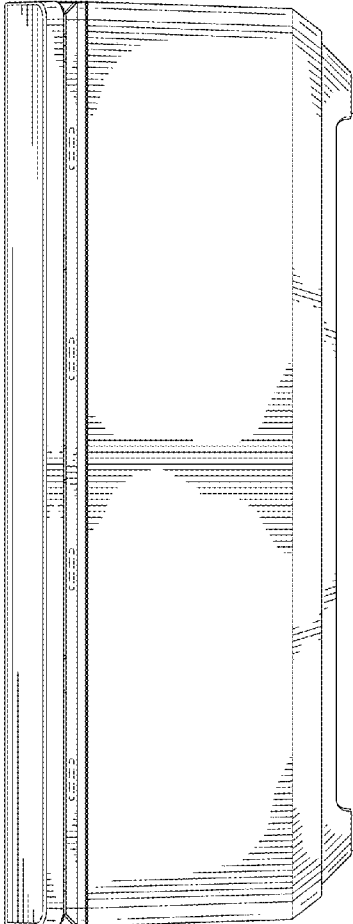

FIG. 3

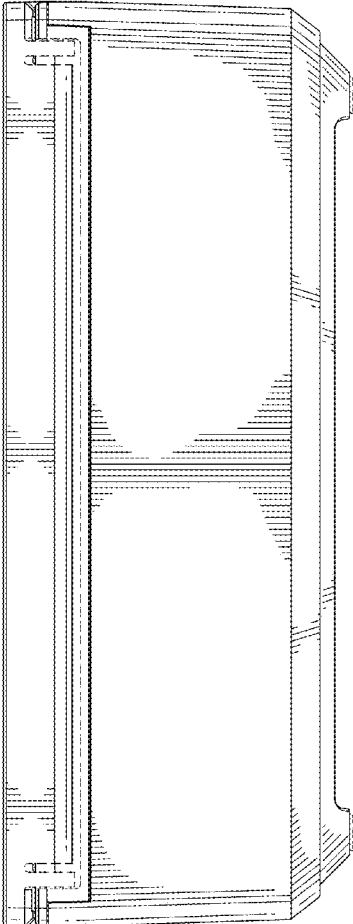

FIG. 4

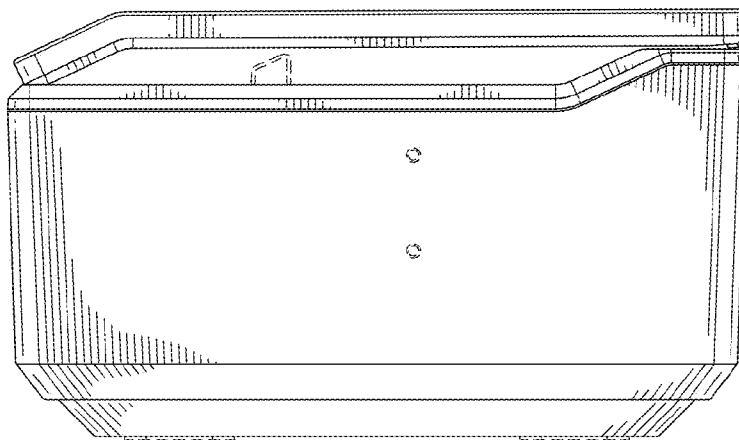

FIG. 5

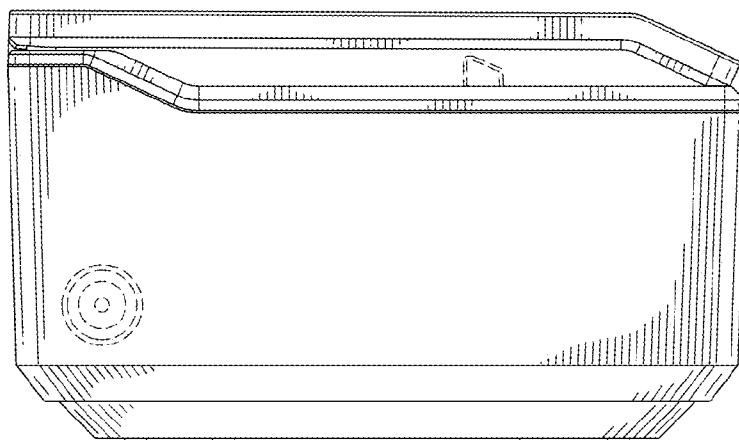

FIG. 6

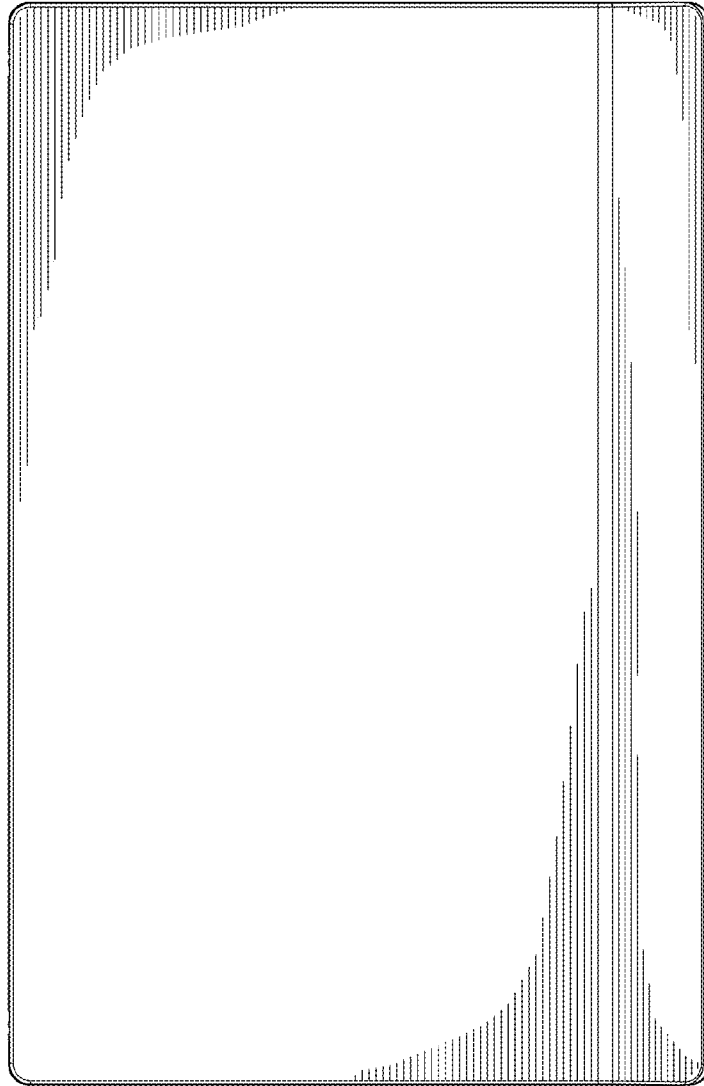
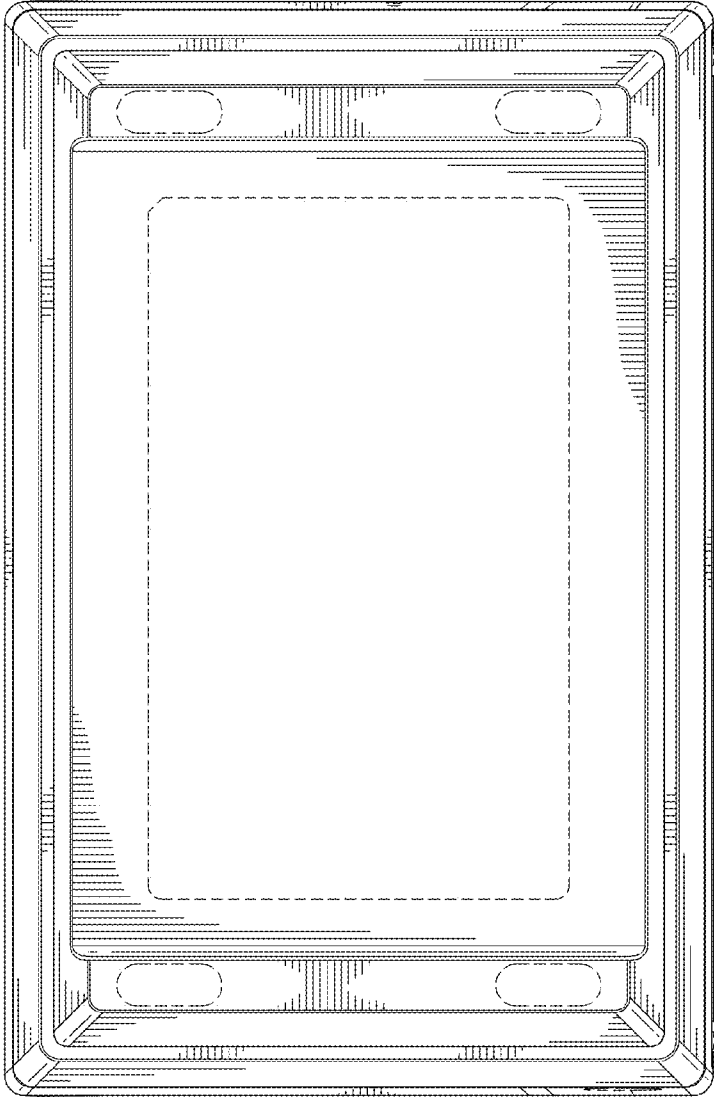

FIG. 7



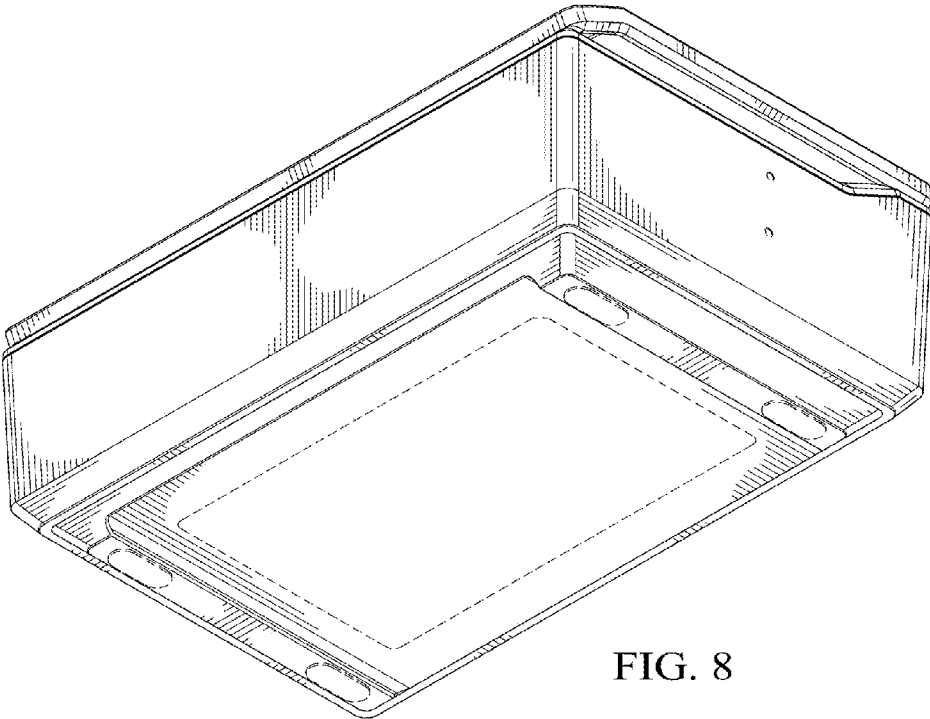

FIG. 8

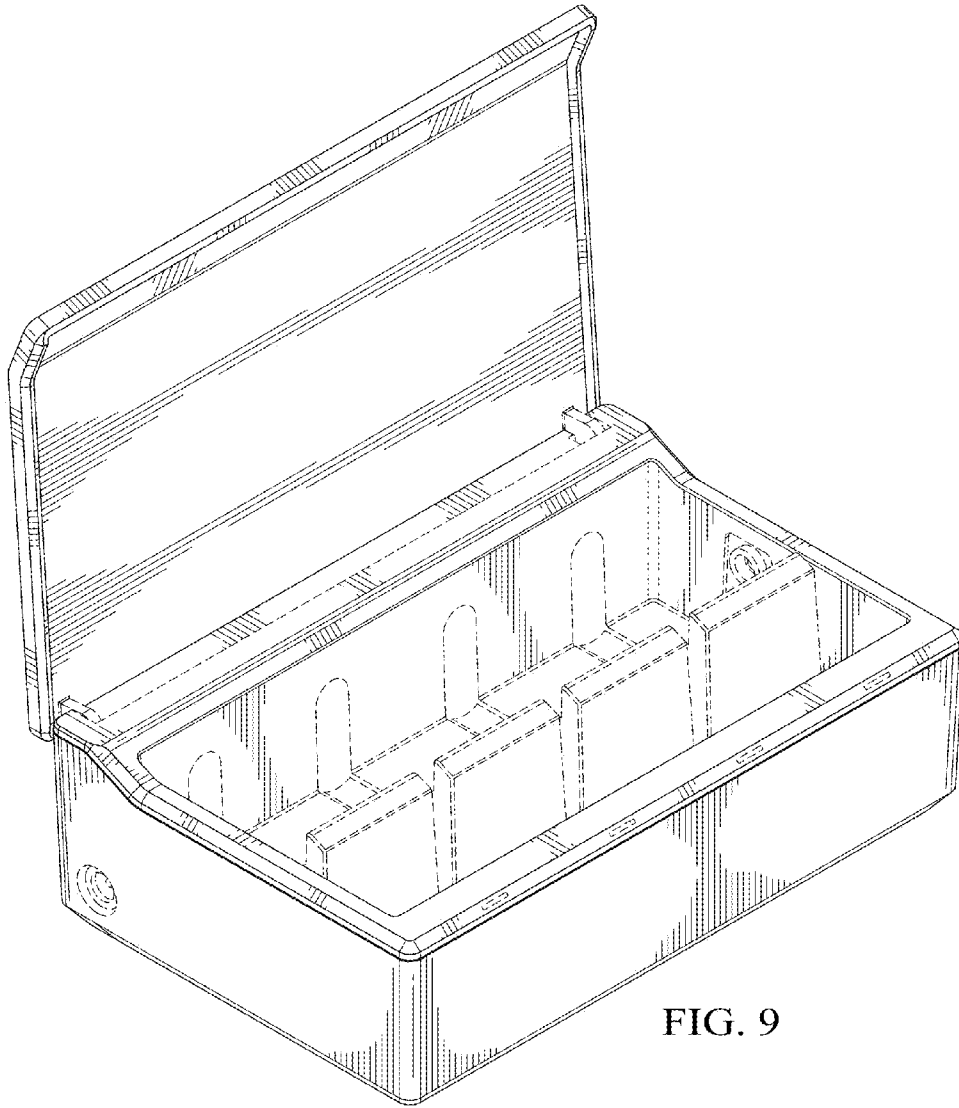

FIG. 9

FIG. 10

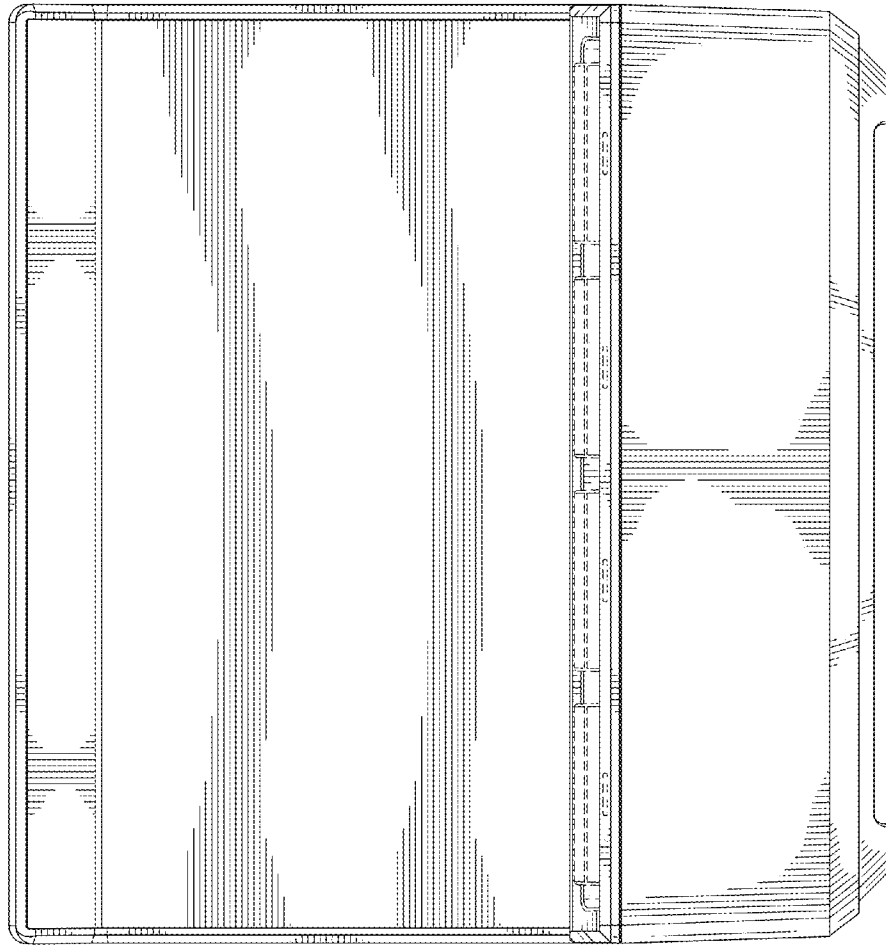
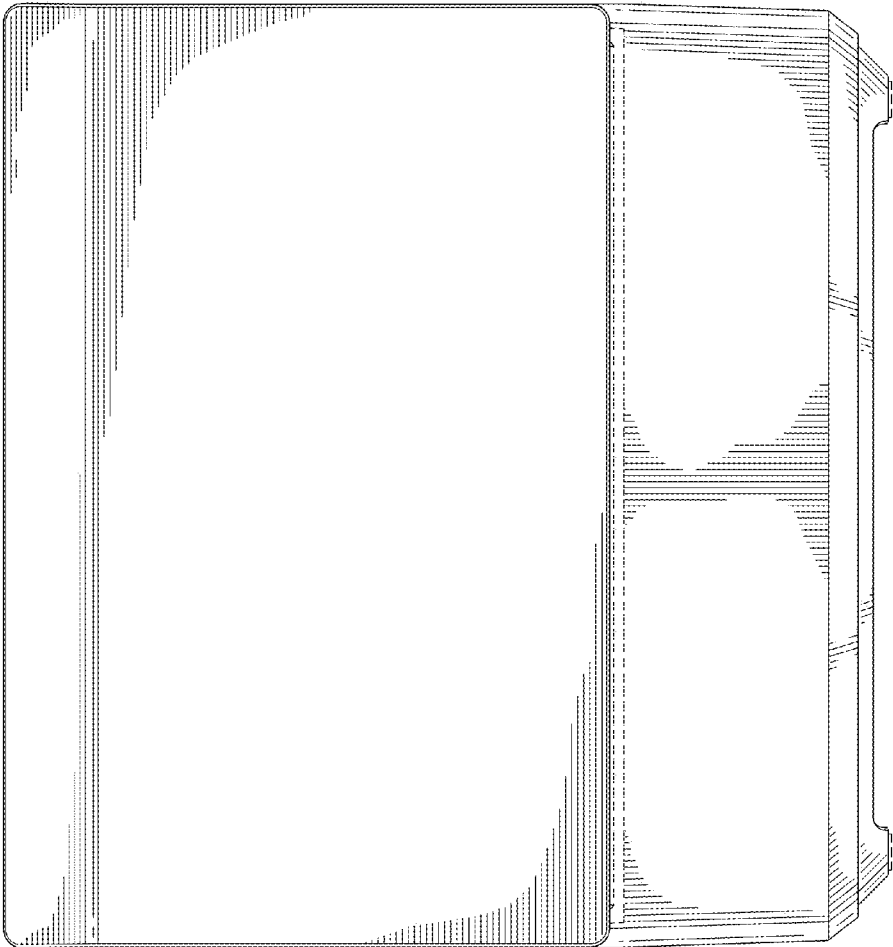

FIG. 11



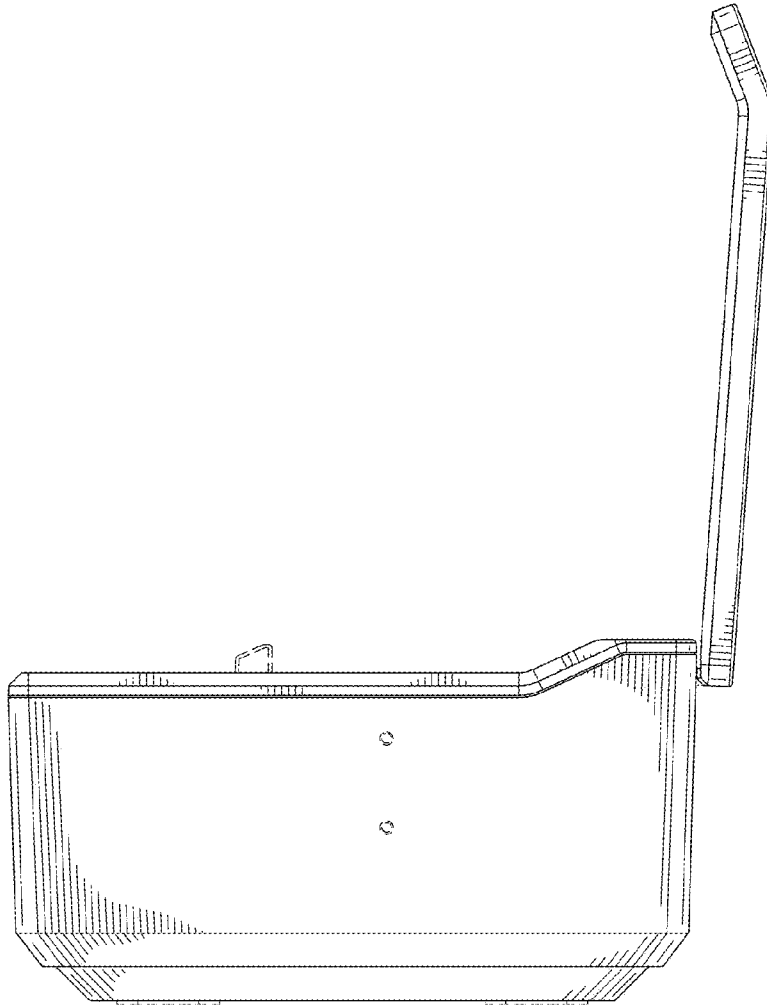

FIG. 12

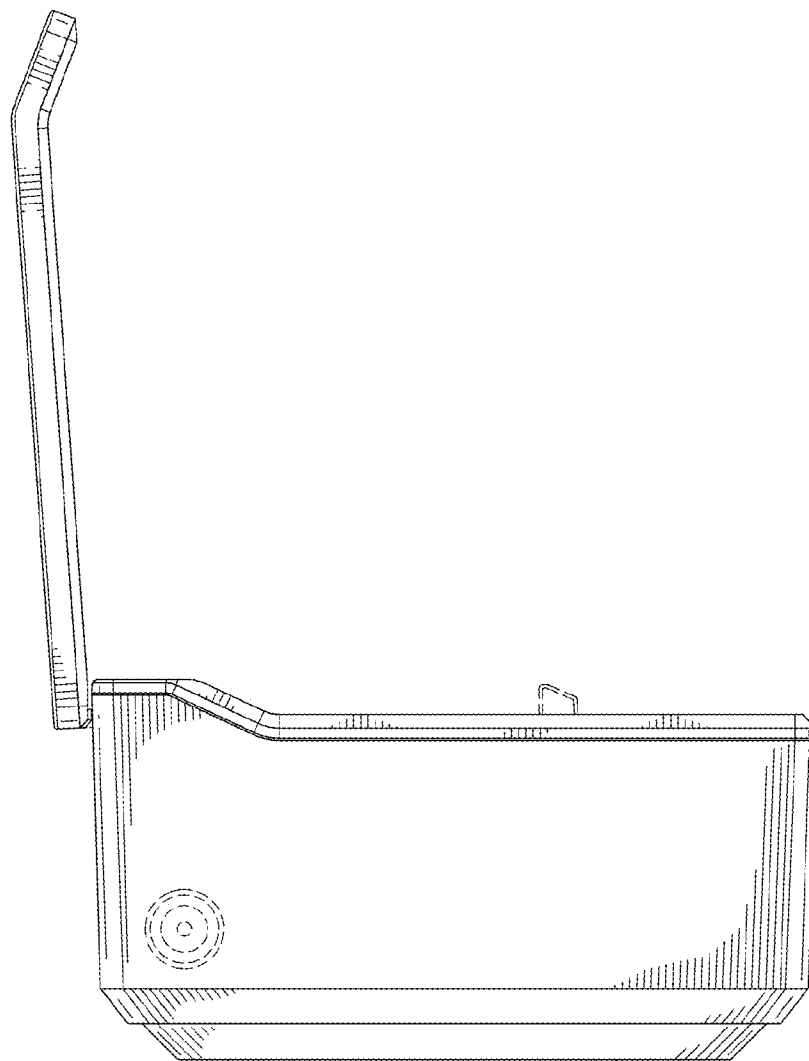

FIG. 13

FIG. 14

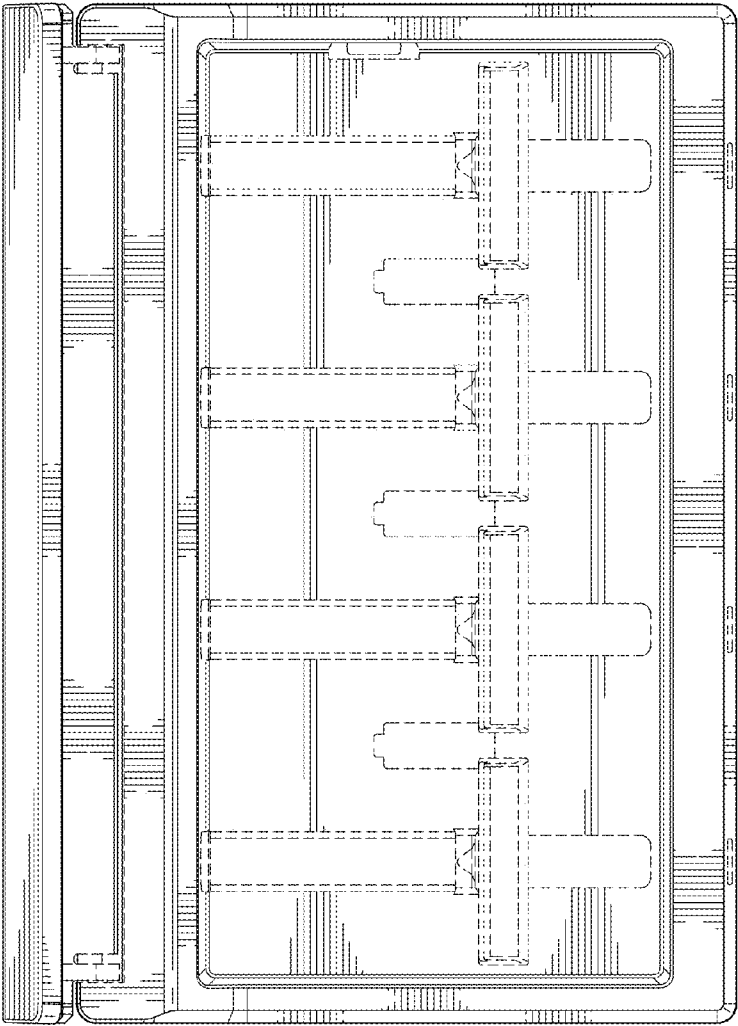
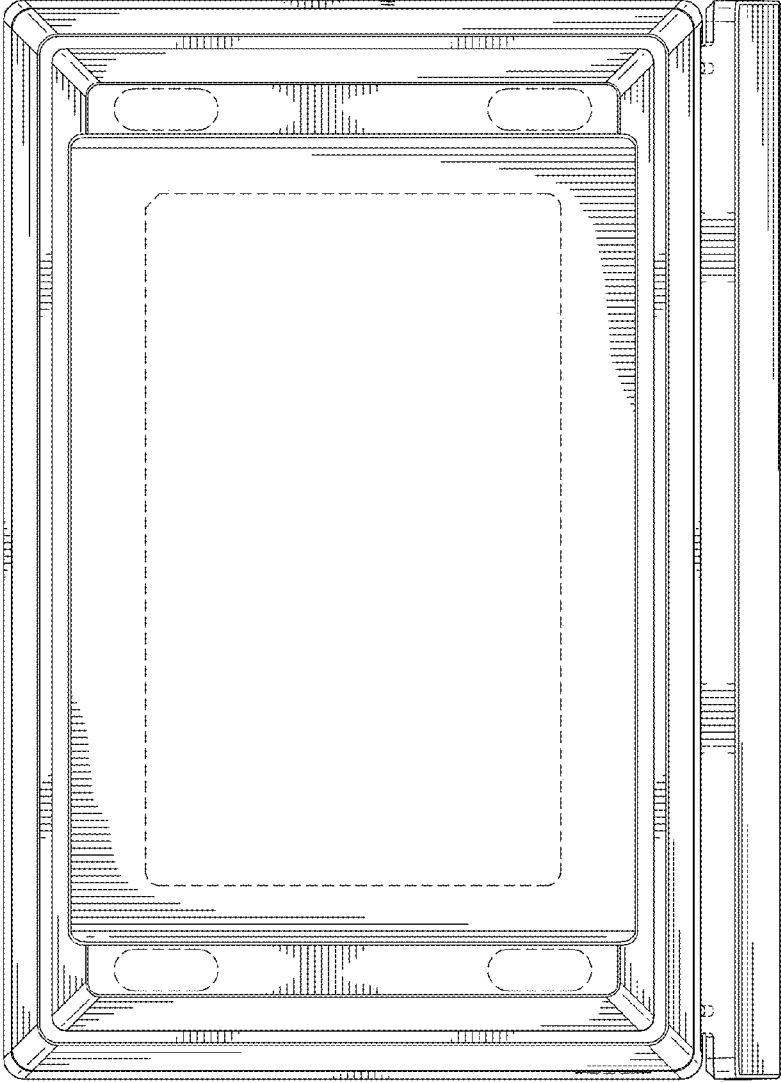

FIG. 15



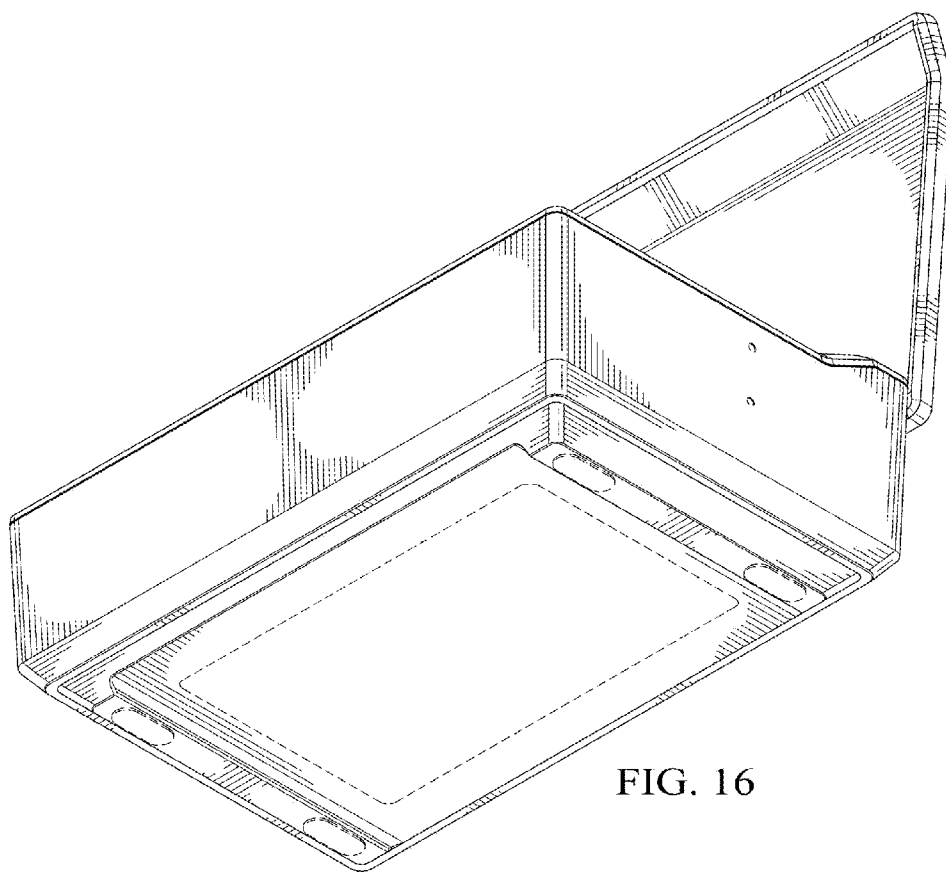

FIG. 16