

REPUBLIC OF SOUTH AFRICA  
PATENTS ACT, 1978**PUBLICATION PARTICULARS AND ABSTRACT**

(Section 32(3)(a) – Regulation 22(1)(g) and 31)

OFFICIAL APPLICATION NO.

LODGING DATE

ACCEPTANCE DATE

21 01 2003/5876

22 4 MAR 2002

43 30-7-04

INTERNATIONAL CLASSIFICATION

NOT FOR PUBLICATION

51 A61B

CLASSIFIED BY: WIPO

FULL NAMES OF APPLICANT

71 WOODWELDING AG

FULL NAMES OF INVENTORS

72 1. AESCHLIMANN, MARCEL  
2. TORRIANI, LAURENT  
3. LANCI, ANTONINO  
4. MAYER, JÖRG

EARLIEST PRIORITY CLAIMED

COUNTRY

NUMBER

DATE

33 CH

31 387/01

32 2 MAR 2001

TITLE OF INVENTION

54 IMPLANTS, DEVICE AND METHOD FOR JOINING TISSUE PARTS

57 ABSTRACT (NOT MORE THAT 150 WORDS)

NUMBER OF SHEETS 40

If no classification is finished, Form P.9 should accompany this form.  
The figure of the drawing to which the abstract refers is attached.

Abstract

In order to form positive connections with human or animal tissue parts, particularly bones, implants (7) are used that at least partially consist of a material that can be liquefied by means of mechanical energy. Particularly suitable materials of this type are thermoplastics (e.g. resorbable thermoplastics) or thixotropic materials. The implants (7) are brought into contact with the tissue part, are subjected to the action of ultrasonic energy and are simultaneously pressed against the tissue part. The liquefiable material then liquefies and is pressed into openings or surface asperities of the tissue part so that, once solidified, it is positively joined thereto. The implantation involves the use of an implantation device comprising a generator (2), an oscillating element and a resonator (6), whereby the generator (2) causes the oscillating element to mechanically oscillate, and the element transmits the oscillations to the resonator (6). The resonator (6) is used to press the implant (7) against the tissue part whereby causing oscillations to be transmitted to the implant (7). The implants (7) are, for example, pin-shaped or dowel-shaped and are used in lieu of screws for forming connections with bone tissue, whereby the bone tissue is optionally pre-bored for positioning the implant (7). By virtue of the fact that it is unnecessary to transmit any torsional forces to the implants (7), these implants can be provided with a design that is weaker, i.e. slimmer than that of known screws made of the same material, and they can be implanted more quickly.

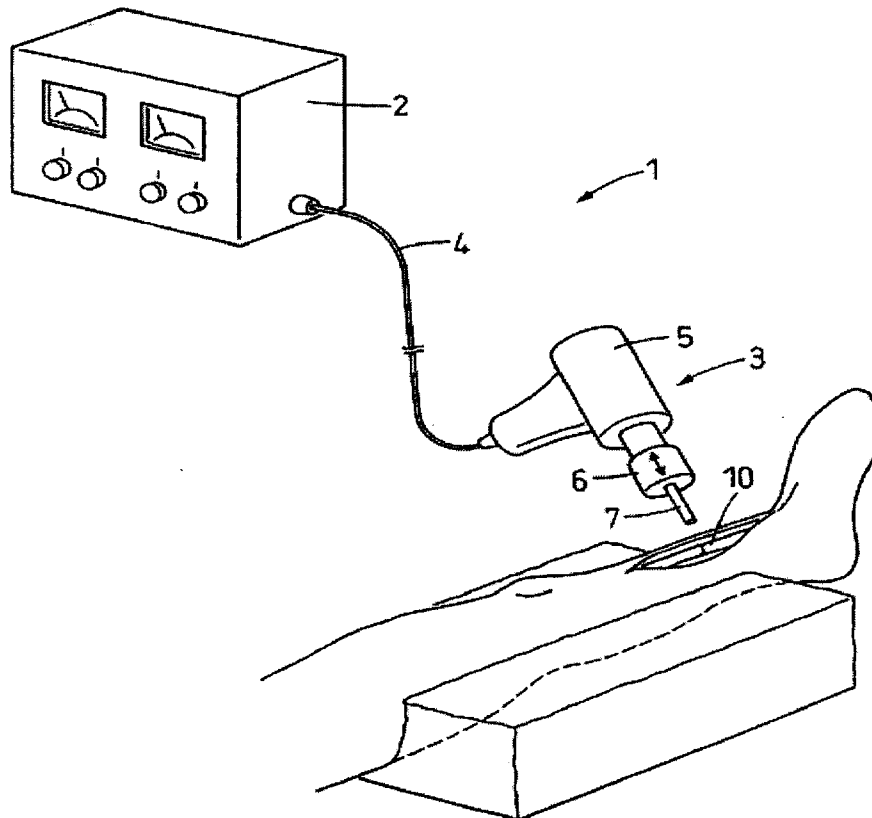

5

The invention relates to an implant according to the preamble of the first independent patent claim. The implant serves for the creation of at least partly positive-fit connections to human or animal tissue parts, in particular to skeletal parts, wherein with the help of the implants tissue parts are connected to one another, or tissue parts are connected to means supporting or replacing tissue parts, or to other therapeutic auxiliary devices. The invention further relates to a device and to a method according to the preambles of the corresponding independent patent claims. Device and method serve for the implantation of the implants.

15

Known implants for creating connections to skeletal parts (bones) are for example screws, pins, agraffes etc., and they are used for connecting bones to bones, or bones to artificial, carrying, stabilizing, supporting parts, or to parts replacing skeletal parts (stabilization or fixation plates, sutures, wires, artificial joint elements, artificial teeth, etc.). Such connection elements for implantation consist for example of metal or plastic, also of resorbable plastic. After healing they are removed by a further operation or they are left in the body where they are possibly gradually decomposed and replaced by vital tissue.

25

For stabilizing a bone fracture, a fixation plate with suitable holes is e.g. fixed in the region of the fracture using screws as mentioned above. Plate and screws consist e.g. of metal (e.g. stainless steel or titanium). The screws are self-cutting and are rotated into threadless openings in the bone, or they are screwed into pre-drilled threaded openings. Pins and agraffes are knocked into previously created openings for similar purposes. Connections created in the named manner are usually based on frictional engagement, possibly on positive fit.

30

In all cases, large forces (torsional forces and impact forces) are to be applied on implantation, and possibly also on removal. This often means that the implants need to have a higher mechanical stability for implantation and removal, than for the load which they are to bear when implanted. In particular for implants of resorbable plastics having a significantly lower mechanical strength than metal, this leads to the fact that the implants must have relatively large cross sections, and thus, for implantation, undesirably large openings need to be created in the vital tissue.

35

Implantation of the named connection elements may also generate considerable quantities of heat and therewith impair the surrounding tissue, in particular due to the friction to be overcome for producing a frictional engagement. This applies in particular to the cutting of threads, the screwing-in of self-cutting screws and the knocking-in of implants without prior drilling.

It is known also to use curable, plastic materials (e.g. particular cements on a hydraulic or polymer base) for creating connections of the mentioned type. Such materials are pressed from the outside between implant and vital tissue or into tissue defects in a highly viscous condition, and are cured in situ. Positive-fit connections can be created using such material, if the openings into which the material is pressed comprises suitable undercuts.

It is the object of the invention to provide implants for creating positive-fit connections to tissue parts (in particular to bone parts, cartilage parts, tendon parts, ligament parts, but also to parts of other tissues), said implants being able to be implanted in a simple manner, with low forces, and fast and said implants being able to provide very stable connections immediately after implantation (primary stability). Furthermore, it is desired that the implants create fewer problems with regard to heat quantities and stress concentrations than is the case with at least some of the known implants, and that the volume of foreign material to be implanted can be further reduced. It is a further object of the invention to provide a device and a method for implanting the implants.

The objects are achieved by the implants, the device and the method as defined in the patent claims.

The invention exploits the per se known fact (e.g. from the publication WO-98/42988), that in particular thermoplastic polymer materials can be liquefied in a targeted manner by way of mechanical oscillation and, in this condition, can be pressed into cavities (e.g. pores of wood) by way of hydrostatic pressure, such creating positive fit connections after solidification.

According to the invention the implants serving for creating positive-fit connections to tissue parts consist at least partly of a material which can be liquefied at a relatively low temperature (<250°C) by way of mechanical oscillation energy (in particular ultrasound), i.e. by internal and/or external friction, such that the material can be pressed into pores or other openings of the tissue part by the effect of external pressure to form positive-fit connections when re-solidified.

Polymers which are plastifiable at relatively low temperatures are suitable as the material to be liquefied by mechanical energy in the implants according to the invention, in

particular thermoplasts which are already known to be medically applicable. Such thermoplasts, being non resorbable are e.g.: polyethylene (PE), polymethyl metacrylate (PMME), polycarbonate (PC), polyamide, polyester, polyacrylates or corresponding copolymers. Such thermoplasts being resorbable are e.g. polymers based on lactic acid and/or glycolic acid (PLA, PLLA, PGA, PLGA etc.), as well as polyhydroxyalkanoates (PHA), polycaprolactones (PCL), polysaccharides, polydioxanones (PD), polyanhydrides or corresponding copolymers. Per se known hydraulic or polymeric cements having thixotropic properties are likewise suitable: e.g. calcium phosphate cements, calcium sulphate cements or methacrylate cements. Such cements may also contain thixotropically prepared, native tissue or transplanted materials. Thanks to their thixotropic properties such cements can be brought from a highly viscous condition into a fluid condition by applying mechanical energy (in particular ultrasound) and without an increase in temperature.

For implantation, the implant according to the invention is brought into contact with the tissue part (on the surface or in an opening which as the case may be has been created specially for the implant), and is then impinged with ultrasound energy and at the same time is pressed against the tissue part. By a suitable design of the implant and by a suitable metering of the energy it is ensured that only a required minimum of the liquefiable material is liquefied in a locally targeted manner. As soon as sufficient material is liquefied and pressed in, the supply of energy is stopped so that the liquefied material solidifies in its new shape, wherein the pressure on the implant is advantageously maintained.

For implantation, the mentioned materials are thus not liquefied by external heat but by mechanical energy (oscillation energy, vibration energy), i.e. as a result of internal and/or external friction. Thereby the thermal burden to the surrounding tissue remains low. A very high shear effect is achieved between different material phases by way of the mechanical energy. This contributes to the uniform liquefaction and achievement of low viscosity and still low burdening of the surrounding. The material liquefied in this manner is then pressed into pores or openings of the surrounding tissue by way of hydrostatic pressure, such permeating the surrounding tissue and thereby enforcing it.

If so required, it may be advantageous to admix additional substances to the liquefiable material for further functions, e.g. substances which mechanically reinforce the material, which let it swell up in a secondary reaction or form pores therein, substances which are to be released into the vital surroundings for promoting healing or regeneration, or substances which are to assume other functions. Such healing-promoting and regeneration-promoting substances are e.g. growth factors, antibiotics or inflammation-inhibitors. Such substances can be brought to a desired location or may be distributed in a tissue region in a targeted manner by the flow of the liquefied material, and in the case of a resorbable material, may be set free in a delayed manner.

Using connection implants according to the invention, pointwise or larger-surface connections can be realized. The load distribution on the connection can be influenced and controlled in a targeted manner. For example, with implants according to the invention it is possible to fasten a fixation or stabilization plate on a bone surface either over a large surface (see e.g. Figures 15 or 16) or pointwise and depth-effective (see Figs. 2 to 4). More superficial connections are e.g. achieved with plates or other support or fixation devices having integrated liquefaction zones or complete liquefaction layers which for being connected to a bone are positioned on the bone and are subsequently excited with mechanical energy (e.g. ultrasound vibration) at least locally. The liquefiable regions are advantageously provided with energy directors or are in contact with energy directors. Energy directors which encourage local liquefaction by concentration the oscillation energy are projecting elements, e.g. pyramids, conical, hemispherical or rib-like elements.

Depth-effective anchorings are achieved by pin-like or dowel-like implants which have a cross section (or cross-sectional geometry), which is constant or changes over their length, and which completely or partly consist of the liquefiable material. They are positioned on the surface of the tissue or in the tissue and are then excited. These implants are advantageously designed such that liquefaction starts at predefined locations (tip or specific stem regions). Controlled liquefaction may also be achieved by energy directors (projecting elements shaped in a defined manner). Depth-effective anchoring is achieved by bringing the implant into the tissue to be connected. The hydrostatic conditions can be such that the liquefied material is pressed into the adjacent tissue under a large pressure.

The device for implanting the implant according to the invention, i.e. the device for liquefying the liquefiable material in contact with the tissue part, and for pressing it into the tissue, may additionally serve or active temperature control in surrounding tissue and material, such that unreasonable quantities of heat and high temperatures and tissue damage caused thereby can be prevented. The implantation process is controlled by actively controlling the device regarding supplied and removed energy (heat distribution and heat management) and where appropriate by suitably arranged sensors and heat conducting elements. Such implantation is controlled by metering the supplied energy and by dissipating excess energy.

The energy used for material liquefaction is preferably produced by piezoelectric or magneto restrictive excitation. An oscillation unit (e.g. piezoelement plus sonotrode) which is activated into oscillation by a generator, transmits waves in the frequency region of about 2 to 200 kHz, preferably ultrasound (e.g. 20 or 40 kHz) to the implant being actively connected to it (pressed against it). The implant is coupled to the bone or tissue to be connected in a manner such that the sound energy is absorbed internally or on the surface by the liquefiable material,

whereby this material is liquefied at least locally. The liquefaction process is achieved by a large shear effect. Internal friction and thus internal liquefaction can be enhanced by a second component having a different density and being locally embedded in the material to be liquefied (e.g. as globules). The same effect is exploited when using a thixotropic, particulate cement as an implant or implant part.

The connections produced by the method according to the invention are mainly positive fit connections, wherein the positive fit means may be very small on both sides (surface unevennesses, surface roughness, or tissue pores) or larger (larger cavities in the tissue or between tissue parts or mechanically created openings or cavities in the tissue). The connection implants are mechanically excited by way of ultrasound in a manner such that they are liquefied in a controlled manner in particular in the contact region with the tissue part or in their interior. Liquefaction usually takes place on a tissue surface or in a suitable opening in the tissue, the opening being made by penetration of the connection implant through the tissue surface or before implantation by using other mechanical means.

The incorporating of the liquefiable material into the tissue in a depth-effective manner can in a very simplified and schematic way be compared with the effect of a piston in a hydraulic cylinder. The not yet liquefied material of the connection implant is seated in a tissue opening and essentially fills and seals it. Since the liquefied material cannot escape from the opening, a hydrostatic pressure is created on account of the load acting from the outside (pressure on the implant). Due to the pressure and the oscillation the liquefied material is pressed into existing and/or newly formed cavities of the surrounding material to be connected (vital tissue). The penetration depth depends inter alia on the nature of these surroundings, on the operating parameters and on the liquefiable material (in particular its viscosity). The quantity of material pressed into the tissue can be determined through the liquefiable or liquefied volume of the connection implant. If a lot of liquefied material is required or the size and number of the cavities present in the tissue is not known, it is possible to use implants or implant components which can be supplied quasi infinitely.

Stress peaks produced by the displaced and compressed material which may lead to failure, e.g. bursting of the tissue are avoided by targeted application of ultrasound and mechanical or hydrostatic pressure the two being coordinated to one another, as well as by a suitable design of the implants and the liquefiable materials arranged thereon. Cavities and gaps in the tissue are filled by the liquefied material, in the case of sufficiently porous tissue even without predrilling. At the same time, the tissue in contact with the liquefiable material is compressed in a controlled manner such that the resulting retention of the connection implant is strong even in heavily porous tissue (e.g. osteoporotic bone tissue). Through the described effects the implant according to the invention can resist large mechanical drawing forces or

loads. In a later phase of the healing process, loadability is reduced in a controlled manner or is taken over by regenerated tissue (secondary stabilisation) if the implant is made at least partly of resorbable material.

5           The invention is suitable for example for anchoring a tooth prosthesis in a jaw. The tooth prosthesis preferably comprises a standardized base part designed as an implant according to the invention and being connectable to various crown parts. The base part consists completely or partly of a material being liquefiable by mechanical energy which material when positioned in an opening in the jaw bone, is liquefied by excitation with mechanical energy and is pressed into  
10 pores of the bone tissue. Thereby, the implant adapts itself to the opening and to the tissue pores and is such immediately after implantation stabilized (primary stabilisation) and well-anchored not only in the tooth root opening but also in the adjacent bone tissue, such forming a suitable base part for fastening the crown part. If the liquefiable material is resorbable the named primary stability is later at least partly replaced by a secondary stabilization due to regenerated bone  
15 tissue.

A further field of application of the invention is e.g. the field of artificial joint elements. An artificial joint socket as well as a joint ball or its stem may be connected to the vital bone tissue or anchored therein by way of implants according to the invention. In addition to the gentle  
20 transmission of the loads on implantation, the materials taking part are selected such that jumps in stiffness are largely avoided, which contributes positively to the life duration of the implant.

The device used for the implantation of the implant according to the invention comprises a generator for producing electrical oscillation to be transmitted to an oscillation unit via  
25 transmission means, e.g. a cable. The oscillation unit comprises an oscillation element (drive unit) and a resonator, the two being actively connected to one another. The drive unit (e.g. piezoelement) excites the resonator into oscillation. The oscillation of the resonator is transmitted to the implant directly or via a transmission means. Due to the oscillation the implant is liquefied at least locally by inner liquefaction or by contact with a non-oscillating environment (tissue part  
30 or another implant part). During excitation, the implant may be held using a suitable holder and/or may be guided by way of a guide element. For minimal-invasive surgery, it is particularly suitable to fasten the implant directly on the oscillation unit. Holding and/or guide means may be equipped not only for temporarily holding or fixing the implant but also for temperature management (in particular heat dissipation).

35           Due to the way in which the material of the implant is liquefied in a targeted and local manner, no large quantities of heat are produced. Additionally the temperature of the tissue regions adjacent to the implant may be actively controlled by way of temperature management, for example by way of heat conducting elements which act to dissipate heat in a targeted manner,



or by way of cooling fluids (e.g. sterile ringer solution) which act in a temperature-controlling manner.

5 The method for implantation of the implant according to the invention e.g. on the human or animal skeleton is carried out as follows: the implant is brought into contact with the skeleton part, then mechanical oscillations are produced and transmitted to the liquefiable material of the implant whilst the implant is pressed against the skeleton part. Mechanical energy is supplied until the liquefiable material is sufficiently liquefied and in the region of contact penetrates into the bone tissue or at least the surface unevennesses of the skeleton part. The mechanical  
10 oscillation is then stopped for re-solidification of the liquefied material during which it is advantageous to maintain the hydrostatic pressure. The re-solidified material anchors the implant in the skeleton part with a positive fit.

15 The connection implants according to the invention have the shape of pins, dowels and/or plates or films. These serve the connection of tissue parts amongst one another, or of tissue parts to artificial elements.

20 For implantations of the above-described manner it is advantageous to use a kit or a set comprising at least one type of implant according to the invention, advantageously a selection of variously dimensioned implants suitable for the field of application, as well as a device for carrying out the implantation. Advantageously the kit also comprises means for the sterile use of the device (sterile coverings for the device) and, as the case may be, exchange pieces of components (in particular resonator, distal resonator part or transmission part) being able to be sterilized. By way of different shapes the resonator parts are e.g. adapted to various implants  
25 and/or applications. Furthermore, the kit advantageously comprises instructions for implantation, details on implantation parameters and further auxiliary means for preparing the tissue part (e.g. drills matched to the implants), positioning instruments, control instruments and/or implant guides adapted to implants and/or resonators.

30 The kit or set is preferably kept complete by subsequent provision of implants. The selection is directed to the demands and may change with time. The subsequent provisions (replacement and addition kit) on the one hand comprise replacements for used implants and new implant types, again for example with suitable means for tissue preparation, positioning instruments, control instruments, adapted resonators or resonator parts, implant guides and  
35 particular corresponding implantation instructions.

The invention is explained in more detail by way of the subsequent Figures, wherein:

- Fig. 1** shows an exemplary embodiment of the device for implanting implants according to the invention, and its use;
- Fig. 2** shows a fixation plate fastened on a bone by implants according to the invention;
- Figs. 3 and 4** show examples of implants according to the invention, to be used e.g. in the application according to Fig. 2, and connections between bone and plate created therewith;
- Figs. 5a to 5e** show exemplary cross sections of pin-like implants according to the invention, the implants comprising axially extending energy directors;
- Figs. 6 to 8** show longitudinal sections through two exemplary, pin-like implants according to the invention, the implants comprising implant parts of a non-liquifiable material;
- Figs. 9 to 13** show exemplary embodiments of cooperating holding means on pin-like or dowel-like implants and resonators;
- Fig. 14** shows applications of implants according to the invention on a human skull or jawbone;
- Figs. 15 to 17** show implants applicable e.g. in the skull region and exemplary connections between two skull parts created therewith;
- Fig. 18** shows an exemplary resonator arrangement for applications as shown in Figs. 16 and 17;
- Fig. 19** shows a further application of implants according to the invention in the region of the human vertebral column;
- Fig. 20** shows a further application of implants according to the invention for fixing a tooth replacement;
- Figs. 21 and 22** show in section two exemplary implants according to the invention suitable for the application as shown in Fig. 20;

- Fig. 23** shows a fixation device fixed to a forearm bone by implants according to the invention;
- Fig. 24** shows an example of a connection implant suitable for the application as shown in Fig. 23;
- Fig. 25** shows in section the fixation device according to Fig. 23 being fastened on a bone by implants according to Fig. 24;
- Fig. 26** shows a further example of a connection implant suitable for the application as shown in Fig. 23;
- Fig. 27** shows a trochanter plate for fixing a broken neck of a joint, the plate being fixed with the help of an implant according to the invention;
- Fig. 28** shows a stem for an artificial joint ball, the stem being fastened to a tubular bone with an implant according to the invention;
- Fig. 29** shows a joint ligament being fastened to bones by implants according to the invention;
- Fig. 30** shows a section through a tissue cavity, for example caused by a tumour, the cavity to be filled or filled with an implant according to the invention.

**Figure 1** schematically and in a very simplified manner shows an exemplary embodiment of an implantation device 1 applicable for implanting implants according to the invention.

The device 1 comprises a generator 2 and an oscillation unit 3 the two being connected via a cable 4. The oscillation unit 3 which is partly accommodated in a housing 5 is designed as a hand apparatus to be used like e.g. a hand drill. The oscillation unit 3 comprises an oscillation element integrated in the housing 5 (not shown in detail) and actively connected to a resonator (sonotrode) 6. At least a distal resonator part projects out of the housing 5. The generator 2 supplies the oscillation element with energy. Excited by the oscillation element, the resonator oscillates at a predefined frequency or as the case may be with a predefined frequency pattern. Frequencies of 2 to 200 Hz and resonator amplitudes of 1 to 100µm in the direction (z-direction) indicated by the double arrow are particularly suitable. The frequencies may be set depending on the application, on the materials to be liquefied and on the shape of resonator and implant. It is also conceivable to superimpose additional mechanical oscillations e.g. with a lower frequency

and larger amplitude on the vibrations in the ultrasound region. In many cases it is sufficient to design the device for a single oscillation frequency, for example for 20 or 40 kHz and for a resonator amplitude of e.g. approx. 20 or 30  $\mu\text{m}$  in the z-direction (direction in which an implant 7 is pressed by the resonator 6 against a tissue part). For controlling the power (supplied energy per unit of time) the excitation may be pulsed, wherein pulse distances and/or pulse lengths are set.

Advantageously and in a per se known manner, the oscillation frequency and the resonator shape are matched to one another such that the resonator oscillates in a standing wave and such that its distal end being pressed against the implant has a maximum amplitude in the z-direction. It is further advantageous to give pin-like implants a length which is matched to a predefined excitation frequency and predefined implant material.

The distal end of the resonator 6 may be designed for holding an implant 7 as is shown in Fig. 1. This simplifies positioning of the implant on a tissue part or in an opening of a tissue part, e.g. the bone of a leg 10. For positioning and implantation without an opening it may also be advantageous to provide an implant guide which is supported on the housing 5 or on the tissue part. It is also possible to design the resonator with a planar end face like a hammer and to simply press it against an implant held in a tissue opening or held by way of a suitable separate mounting or guide means. The distal end face of such a resonator must not stick to the implant during implantation. This is achieved by a suitable, non-adhering end-face of the resonator or by an implant part adjoining the resonator part which consists of a non liquefiable material.

For being applicable in a sterile operation region, the device is for example used in a sterile covering. Advantageously the sterile covering comprises an opening for the distal part of the resonator and the resonator or a distal resonator part can be dismounted for exchange and sterilization.

Other exemplary embodiments of the implantation device 1 according to the invention are for example designed as hand apparatus comprising all components (including energy supply) or as completely stationary apparatus.

**Figure 2** shows a fixation or stabilization plate 21 being fastened by implants 7 according to the invention on a bone part in the region of e.g. a bone fracture or laceration, in order to stabilize the fracture or laceration. The bone part 20 in this case comprises a relatively thin but relatively compact, outer cortical layer 22, and below this cancellous bone tissue 23 which is porous. Other than shown in Fig. 2, the transition of the cortical bone to the cancellous bone in natural tissue is a gradual transition in which the tissue becomes more and more porous.

The implants 7 extend through openings in the plate 2, through the cortical bone substance 22 and into the cancellous bone 23 and they are anchored at least in the cancellous bone 23.

5 **Figures 3 and 4** in section and in an enlarged scale, show two examples of implants according to the invention which for example may be used for the application shown in Fig. 2. Fig. 3 shows an implant after implantation, Fig. 4 another implant which is positioned in an opening 24 of plate 21 and cortical bone substance 22 for impingement with oscillation energy.

10 For implantation, at least the cortical substance layer is to be opened, for example by drilling. A suitable bore may also continue into the cancellous bone 23 as a pocket hole. Since the cortical substance of the bone has no suitable pores for pressing in the liquefied material, such openings or surface unevennesses may be created e.g. by cutting a thread 25 or by roughening the inner walls of the bore. The liquefied material is then pressed into such openings and re-solidified forms a positive-fit connection. The liquefied material of the implant is pressed  
15 into the pores of the cancellous bone 23, and in this manner the implant 7 is anchored in a depth-effective manner. It shows that hydrostatically pressing a liquid material into the tissue pores is significantly gentler on the tissue than mechanically introducing a solid material. For this reason it is possible to create stable connections to tissue not having much mechanical strength e.g. to osteoporotic bone tissue.

20

For connecting the implant 7 to the plate 21, the implant may comprise a head like a mechanical screw, as this is shown in Fig. 2. As shown in Fig. 3, the opening in the e.g. metallic plate 2 may also comprise an inner thread like the thread created in the cortical substance 22 of the bone, the liquefied material penetrating and solidifying in the threads such forming a positive  
25 fit. In this case an implant head is not needed. The implant 7 is aligned flush to the plate 21 not by undesirable trimming of a projecting implant part, but by driving a suitably dimensioned implant to the desired position.

30

For a plate 2 consisting of a thermoplastic plastic, the connection between plate and implant (securement against loosening) may be realized as shown in Fig. 4, as material-fit connection (welding or adhering) simultaneously to the anchoring in the tissue. On driving in the implant, this material-fit connection begins to form at the connection location 26. In this case too the implant 7 is advantageously driven so far in that in the end it is flush with the outer side of the plate 21.

35

Since the implant 7 does not need to be rotated into the tissue, it does not need to be designed comprising means for coupling in a relatively large torsional force as this is the case for known screws. Dimensioning of the implants can therefore be directed purely to their function in the implanted condition, i.e. the implants are more slimline and the openings to be created in the

tissue will be smaller than is the case with conventional screws of the same material. Since the positive-fit is formed by liquefaction and resolidification of the material, it comprises less stress and notches, which further increases its strength and makes it less prone to material fatigue.

5           Implants according to the invention to be anchored in the tissue part in a depth-effective manner, as shown in Figs. 2 to 4, are advantageously pin-like or dowel-like and comprise the liquefiable material for example at their distal end, as well as on further surface regions at which an anchoring is desirable (e.g. in a thread in plate 21 and cortical substance 2 of the bone). For this, as shown in Figs. 2 to 4, they may completely consist of the liquefiable material, wherein  
10 the distal end and the surface regions at which the material is to be liquefied in particular are advantageously provided with energy directors, or energy directors are provided at surfaces coming into contact with these regions. Such energy directors are for example distal implant ends which are pointed or designed tapering to one or more essentially point-like or linear tip regions. Further surface regions to be liquefied comprise e.g. humps, tips or ribs whose height  
15 and widths are to be adapted to the anchoring to be created. The energy directors project at least 10µm beyond the surface. They may also be significantly larger and be designed e.g. as axially running ribs rendering the pin cross section humped or cornered, as this is shown in an exemplary way by Figs. 5a to 5e. Pin-like implants have such cross sections over their entire length or only  
20 over a part of their length.

For pin-like implants to be anchored in the region of their cylindrical surface only or in addition to anchoring in the region of the distal end, tissue openings (e.g. bores) are provided such that introduction of the implant causes at least locally a friction fit between tissue and implant or energy directors respectively, i.e. the tissue openings are slightly narrower than the  
25 cross section of the implants.

For further functions, the liquefiable material may contain foreign phases or further substances. In particular, the material is mechanically strengthened by admixture of fibers or whiskers (e.g. calcium phosphate ceramics or glasses). The liquefiable material may further  
30 comprise in situ swelling or dissolvable, i.e. pore-forming constituents (e.g. polyester, polysaccharides, hydrogels, sodium phosphate) and substances to be released in situ, e.g. growth factors, antibiotics, inflammation reducers or buffers (e.g. sodium phosphate) to combat the negative effects of an acidic breakdown. Admixtures for furthering visibility in x-ray pictures and similar functions are conceivable also.

35           It has been shown that for anchoring in cancellous bone implants according to Figs. 2 to 4 consisting of polymers such as e.g. PC or PLLA and having a diameter of 3 to 4 mm, advantageously forces in the region of 0.5 to 5 N per mm<sup>2</sup> implant cross section are used for the pressing-in. Forces in the named range result in a driving-in speed greater than 5 mm/s.

Figures 6 to 8 show three further, exemplary pin-like implants 7 which additionally to regions of liquefiable material comprise a core 11 (Figs. 6 and 7) or a sleeve 13 (Fig. 8) of a non-liquefiable material, for example of metal, ceramic or glass or of a composite material.

5

The implants according to Figs. 6 and 7 comprise at their distal end a cap 12 of the liquefiable material which is more or less pointed (Fig. 6) or comprises a plurality of pointed or linear end regions (Fig. 7). The cylindrical surface of the core 11 is completely surrounded by liquefiable material (Fig. 6) or only in regions, wherein these regions extend axially, or annular (Fig. 7) or may be regularly or irregularly distributed over the core surface. These regions advantageously comprise energy directors as described above for implants consisting entirely of liquefiable material. The liquefiable material is to be thicker or thinner, depending on the desired penetration depth, but should not be thinner than approx. 10µm.

15

Step-like reductions in cross section as shown in Fig. 6 are suitable as energy directors. Implants with such steps are advantageously implanted in correspondingly stepped or narrowing tissue openings.

20

The impingement of a pin-like or dowel-like implant with a non-liquefiable core 11 may either concern the complete proximal end of the implant or only the annular outer region consisting of the liquefiable material.

25

30

The implant according to Fig. 8 comprises the liquefiable material in the inside of a non-liquefiable sleeve 13. The sleeve 13 is provided with openings arranged in places where anchoring is desired. Such an embodiment of the implant according to the invention is suitable in particular for the application of highly viscous, thixotropic materials as liquefiable material since such a material cannot withstand the mechanical loading caused by the resonator pressing on the implant. The openings in the sleeve are to be dimensioned in a manner such that the highly viscous material can only get through when liquefied. Sleeves 13 of porous sintered material are particularly suitable. An implant with a sleeve 13 is to be positioned in a tissue opening and the resonator is applied only on the liquefiable material, i.e. has a cross section adapted to the inner cross section of the sleeve.

35

At the proximal end of a pin-like or dowel-like implant there may be provided for example a head-like thickening, an artificial part replacing or fixing a further tissue part, a therapeutic auxiliary device, fastening means for such a device, or a fixation means for a suture or cerclage wire. The proximal end may also be equipped as a holding means cooperating with a corresponding holding means on the resonator (see Figs. 9 to 11).

A metallic core 11 for example in a pin-like or dowel-like implant usually serves as a mechanical reinforcement of the implant and is suitably dimensioned for this. The core may however also be significantly thinner and easily removable from the implant. In this case for example it serves the visibility in an x-ray picture during minimal-invasive implantation or as a guide wire and is removed directly after implantation.

An implant comprising e.g. a metallic core and being anchored in the tissue according to the invention and comprising a liquefiable material which is resorbable has a good primary stability immediately after implantation. On resorption of the anchoring material the anchoring loosens or is made dynamic, such that more and more load has to be carried by the tissue itself. This encourages the regeneration process and prevents the atrophy process in many cases. After decomposition of the liquefiable material the core can be removed easily if its surface is designed such that the vital tissue does not grow together with it. If its surface however is designed in a manner such that tissue intergrowth is promoted (bioactive surface), this intergrowth constitutes an ideal, secondary stability for an implant or implant core remaining in the tissue (see also Fig. 28).

Implant cores as shown in Figs. 6 and 7 may not only consist of metal (e.g. steels, titanium or cobalt-chrome alloys) but according to their application they may also consist of polymers (e.g. polyetheraryl ketone, polyfluoro- and/or polychloroethylene, polyetherimides, polyethersulphones, polyvinylchlorides, polyurethanes, polysulphones, polyester) or of ceramic or glass-like materials (e.g. aluminium oxide, zirconium oxide, silicates, calcium phosphate ceramics or glass) or of composite materials (e.g. carbon fibre reinforced high-temperature thermoplasts).

**Figures 9 to 13** show various exemplary applications for holding a pin-like or dowel-like implant according to the invention in or at the distal part of the resonator 6 (sonotrode) of the implantation device 1 (Fig. 1). The holder may for example be a positive-fit holder as shown in Figs. 9 and 10. The positive-fit for example is realized as a snap-closure (Fig. 9) of a resiliently designed proximal extension 14 of an implant core 11 or implant 7 which is introduced into a corresponding opening 15 at the distal end of the resonator 6. The positive-fit may also be realized by a suitably secured pin 16 extending through the resonator 6 and the proximal extension 14 of an implant core 11 or implant. Advantageously the positive-fit is arranged at a distance  $d$  to the distal end of the resonator such that it lies in a node point of the oscillations in  $z$ -direction, i.e. in a position in which the amplitude in  $z$ -direction is essentially zero.

Figure 11 shows a screwed connection 17 between resonator 6 and implant 7, i.e. a non-positive fit or force-fit connection. If this connection is biased in a manner such that the oscillations propagate uninterrupted from the resonator to the implant, the implant 7 becomes a



part of the resonator 6 and is to be designed accordingly. This means that the distal end of the resonator does not necessarily require maximal amplitude in the z-direction but may as well lie on a node point.

5            Figures 12 and 13 show advantageous implant holders on the resonator 6 for implants whose proximal end consist of the liquefiable material. In both cases the proximal implant end is shaped by and bonded to the distal end of the resonator 6 due to the ultrasound effect and suitable energy directors arranged on the resonator. Fig. 12 shows a resonator 6 with a distal surface which is formed as the impact surface of a granulating hammer, Fig. 13 a resonator 6  
10 with a central energy director. In both cases the proximal end of the implant 7 is contacted by the energy directors of the resonator 6 and the resonator is set into oscillation. The liquefiable material in the region of the energy directors of the resonator is liquefied first and bonds to the resonator, wherein it assumes the shape of its distal surface and forms a head 18 in the case which is shown in Fig. 12.

15

Holding of the implant on the resonator as shown in Figs. 9 to 13 is advantageously established before positioning the implant on or in the tissue part, and it is released after implantation, in the cases of Figs. 12 and 13 by way of a force with which the resonator is e.g. bent away or rotated off the implant 7.

20

As further fields of application for implants according to the invention, **Figure 14** shows the fixation of a cover plate 30 of bone or of a man-made material into an opening of the calvaria 29 and the fixation for example of an artificial fixation plate 31 on a broken or fractured jawbone 32. Similar applications are conceivable in reconstruction surgery in the facial region. The connections which are to be created between the cover plate 30 and the surrounding bone tissue are advantageously limited to selected locations of the gap 33 between the plate and the native  
25 bone. The fixation plate 31 is likewise connected to the jawbone at selected plate locations 31'. The connections at the selected locations are realized in successive implantation steps using the implantation device 1.

30

**Figures 15 to 17** in section on an enlarged scale show connections which may be created with implants 7 according to the invention and which for example are suitable for the applications shown in Fig. 14.

35

**Figure 15** shows an implant 7 according to the invention which for an at least local connection between the skull 29 and the cover plate 30 to be fixed in an opening of the skull and e.g. consisting of a porous material (e.g. likewise skull bone) is positioned (above) and then implanted by way of ultrasound energy (double arrow) in order to connect the skull 29 and the cover plate 30 across the gap 33 (below).

The gap 33 is advantageously formed obliquely in a manner such that pressure forces from the outside onto the gap region are accommodated by the calvaria 29, and on the outer side the gap is extended for positioning the implant 7. The implant which for example is spherical or sausage-like and consists of a thermoplastic or thixotropic material is positioned in the extended outer gap region and is impinged with oscillation energy. Thereby the implant material is liquefied and on the one side is pressed into the pores of the calvaria 29 and on the other side into corresponding pores of a cover plate 30 consisting of e.g. bone, or into correspondingly arranged artificially created openings (e.g. dot-dashed groove) in an artificial plate. A positive-fit anchoring is such created on both sides such connecting calvaria 29 and cover plate 30.

**Figure 16** shows a fixation foil 35 which may also have the form of a textile web and which may for example be applied for local fixation of the cover plate 30 in the opening of the skull 29. The foil 35 is for example tape-like and is advantageously flexible. It consists completely of a liquefiable thermoplast or is for example reinforced with a fibre mat or with a similar structure. It is applied over the gap 33 and excited on both sides (double arrows) with the help of an implantation device (Fig. 1) in a manner such that it adheres to the surface of the calvaria 29 and of the cover plate 30 (larger-surfaced, less depth-effective connection which may be limited to a multitude or a pattern of individual fixation points). As the case may be the surface regions at which the implant is to be connected to the material lying therebelow may be suitably pre-treated (e.g. roughened) or suitable surface structures (surface unevennesses, recesses, grooves etc.) are provided on the artificial plate 30. For connecting the film 35 to a bone surface a pressure of the order of 0.5 to 3 N per mm<sup>2</sup> of resonator end face is sufficient.

**Figure 17** shows a fixation plate 36 which is fastened with the help of a fixation film 35 or corresponding textile web over the gap 33 and which, for accommodating accordingly larger forces, consists e.g. of metal and therefore, apart from being used in a skull application may also be used on the jaw as shown in Fig. 13 or in the application according to Fig. 2. The fixation plate 36 consists of a material which is not liquefiable in the context of the invention and at its surface directed towards the tissue to be fixed has a surface structure suitable for a positive fit. The film 35 is positioned between the plate 36 and the tissue or material to be fixed and through the plate 36 is impinged at least locally with oscillation energy and is thus connected to the surface of the calvaria 29 and to the cover plate 30. The positive-fit connection between film 35 and fixation plate 36 may be created during implantation, or the plate 36 with the film 35 already connected to it may be used as a finished implant. In such a two-layer implant the connection between the layers may also be of a material fit (adhesion or welding). The film 35 in such a two-layer implant may also be reduced to a coating of the plate, said coating advantageously not having a constant thickness but in the sense of energy directors consisting of a pattern of humps, points or ribs which have a minimal height (coating thickness) of approx. 10µm.

The fixation plate 31 shown in Fig. 14 comprises film regions 31' arranged for example in suitable recesses and having an outer surface provided with energy directors. These film regions are connected to the jawbone regions lying thereunder.

5

It may be advantageous for the application shown in Fig. 16 to design the resonator to be used in a manner such that the oscillations transmitted to the implant are not aligned perpendicular (z-direction) to the connection plane to be created as indicated with double arrows but parallel to this (x/y-direction). As the case may be a transmission element 37 as shown in  
10 **Fig. 18** is suitable. This transmission element 37 is connected to the resonator 6 with a non-positive fit and specifically at a location in which the wave in the z-direction has a node point (amplitude = 0) and thus the wave in the x/y direction has a maximum amplitude. This oscillation in the x/y direction is transmitted to the film 35 by the transmission element 37.

15

**Figure 19** schematically and greatly simplified, shows as a further application of implants according to the invention, a support element for a human vertebral column region. The support element 40 is elastic and supports the vertebral column region in a lasting or possibly temporary manner. In the context of the invention, the support element 40 is fastened to vertebral bodies in that it consists of a correspondingly liquefiable material and is fastened without depth effectiveness (as shown in Fig. 16), in that it consists of a non-liquefiable material and is  
20 connected to the vertebral bodies through a film and without depth effectiveness (as shown in Fig. 17) or with predrilling and depth effectiveness (as shown in Figs. 2 to 4). The pin-like implants 7 shown in Fig. 19 have for example a head projecting beyond the support element and being made according to Fig. 13. For a lasting support, connecting implants and support element  
25 are made of a non-resorbable material, for a temporary support of a resorbable material.

20

25

**Figure 20** shows the application of a dowel-like implant 7 according to the invention forming a basis for an artificial tooth 40 in a jawbone 32. The implant 7 consists at least partly of a thermoplastic or thixotropic material. On its end face it comprises means for holding the  
30 artificial tooth 40, a bridge or prosthesis. The implant is positioned in the corresponding opening with or without the artificial tooth and is pressed in further under ultrasound vibration. Since at the same time at least a part of the implant liquefies it not only fills gaps between implant and bone in a largely interstice-free manner but is also pressed into the pores of the jawbone so that a depth-effective connection arises as is for example shown in section in **Figure 21**.

30

35

**Figure 22** shows in section a further exemplary embodiment of an implant according to the invention. This implant is particularly suitable for the application shown in Fig. 20. The liquefiable material is not arranged on the outer surface of the implant but within a sleeve 13 which is permeable to the liquefiable material when liquefied, as has already been described in

connection with Fig. 8. The longitudinally sectioned implant is shown to the left of the middle line in a state before application of ultrasound and to the right of the middle line in a state after the application of ultrasound. The sleeve 13 consisting for example of a metallic or ceramic sintered material with an open porosity assumes the bearing function of the implant. In the  
5 shown case it comprises an opening e.g. with an inner thread suitable for fastening a tooth, bridge or tooth prosthesis. The implant comprises a further, annular opening 43 in which the liquefiable material is positioned, for example a cylindrical piece 44 of the liquefiable material. For a targeted liquefaction energy directors 45 are provided in the inside of the annular opening 43 in contact with the liquefiable material.

10 The implant according to Fig. 22 is for example positioned in an opening of a jawbone (41, Fig. 20) and then the liquefiable material is impinged with mechanical energy using a resonator 6 with an annular distal end. By way of this the material is liquefied and pressed through the porous sleeve material into the surrounding bone tissue, whereby the implant is  
15 anchored in this tissue.

For the application shown in Figs. 19 to 20 it is particularly advantageous to select a resorbable material as the liquefiable material whilst the bearing part consists of a material which is neither liquefiable nor resorbable and which has a sufficient mechanical strength for the  
20 fastening of a tooth, bridge or prosthesis. At the same time at least the surface of the central part is bioactive (e.g. porous as described for the sleeve 13), that is to say equipped in a manner such that it promotes an intergrowth with bone tissue. Immediately after implantation, such an implant has a primary stability which is adequate for fastening the tooth, bridge or prosthesis and for normal use thereof. Promoted by the bioactive surface of the central implant part, regenerated  
25 tissue then successively replaces the resorbable material and grows together with the central implant part. The implant according to the invention thus offers an immediate primary stability without the application of cement and, after a resorption and regeneration phase a permanent secondary stability which is equal to the stability of known implants. In comparison to known  
30 implantation methods however there is no transition phase in which according to the state of the art the opening 41 is closed and one waits for regeneration of bone tissue before the tooth, the bridge or the prosthesis is fastened directly in the regenerated bone.

**Figure 23** shows an external fixation device 51 comprising supports 52 and a carrier 53 fastened on the supports 52, which device is for example fastened on a tubular bone 50 of a  
35 human arm according to the invention. The supports 52 are designed as implants according to the invention. The medial part of a tubular bone consists mainly of cortical bone substance and comprises only very little tissue regions which are porous in the context of the invention. For this reason, the marrow space 54 in the inside of the tubular bone 50 is used for the liquefied material to be pressed into. This is shown in **Figs. 24 and 25** in more detail. The supports are provided for

example with base plates 55 since the marrow cannot counteract the hydrostatic pressure with sufficient resistance.

For fastening the fixation device, openings (with a thread 25 as the case may be) are  
5 drilled through the tubular bone 50 extending into the marrow space, wherein the bore diameter corresponds to the diameter of the implant 7 or the base plate 55 respectively. The implant 7 comprises a central support 52, the base plate 55 being fastened to its distal end and an annular or tubular region 57 of the liquefiable material arranged around the support and essentially covering the base plate 55. The implant is introduced into the opening 56 and is held at a predefined depth  
10 with suitable means to be applied externally. Then the liquefiable material 57 around the support 52 is pressed against the base plate 55 under the effect of ultrasound, so that it is pressed between the bone 50 and the base plate 55 into the marrow space 54 and thus forms a positive-fit connection holding the support 52 in the opening 56. This anchoring permits a unicortical fastening of the support 52 which fastening is secure against tilting. According to the state of the  
15 art, such fastening can be achieved only by a bicortical fastening.

**Figure 26** shows a further embodiment of the implant 7 according to the invention which implant is particularly suitable for the application shown in Fig. 23. The liquefiable material, which for example is a thixotropic cement, is arranged in the inside of the support 52, and  
20 openings 58 are provided above the base plate 55 and having a size such that the cement cannot exit in its highly viscous form, but exits in its liquefied form by the effect of the resonator 6. The end of the support 52 is designed as a sleeve in the sense of the sleeve according to Fig. 8. The cement pressed through the openings 58 with the help of the resonator secures the support in the marrow cavity and as the case may be, in the adjacent bone tissue.

25 The implant according to the invention shown in **Figure 27** is a tension screw 60 which for example is used together with a trochanter plate 61 for fixing a broken femoral neck bone. The tension screw 60 (in the sense of an implant sleeve 13, Fig. 8) is hollow and at least in its distal end comprises openings through which a liquefied material can be pressed out in order to  
30 anchor this distal region better in osteoporotic bone tissue than is possible alone with the thread of the tension screw. The thread of the screw thus serves in particular for pulling together the tissue in the region of the fracture, until the distal screw end is anchored in the tissue by the liquefiable material.

35 **Figure 28** shows in a very schematic sectional representation a tubular bone 50 on which an artificial joint element 62 is fastened by way of an implant 7 according to the invention. The stem 63 of the joint element 62 and liquefiable material 57 arranged around the stem represent the implant according to the invention, which is pressed into the tubular bone 50 under the effect of ultrasound, wherein the material 57 is liquefied and is pressed into pores of the cancellous

bone 23 and into unevennesses of the inner surface of the cortical substance 22 of the tubular bone. The stem 63 has a surface structure which is suitable for a positive fit connection to the liquefiable material 57, in the same manner as shown for plate 36 in Fig. 17.

5           A particularly advantageous embodiment of the stem 63 consists for example of titanium and has a porous surface which is thus bioactive and it is surrounded by resorbable liquefiable material. Such an implant has a primary stability directly after implantation which permits an at least partial loading. The primary stability is later taken over by a secondary stability effected by the intergrowth of vital bone tissue into the porous surface of the titanium stem 63. This means  
10 that the artificial joint element may be loaded essentially immediately after implantation but without the use of cement. This early loading favors regeneration of the vital tissue and prevents atrophy (osteoporosis). All the same in a further phase, vital tissue intergrows with the titanium stem.

15           **Figure 29** likewise very schematically shows a joint 70 in the region of which a ligament 71 connects the bones 72 and 73. The ligament 71 is naturally intergrown with the bone, wherein this connection may tear on overloading. Implants 7 according to the invention can be used for the repair, wherein implant embodiments according to Figs. 2 to 4 may be used. For the repair, the cortical substance of the joint bone is opened and pin-like implants 7 are driven through the  
20 ligament 71 and secured externally with a head (e.g. according to Fig. 13). Embodiments with less depth effectiveness according to Figs. 16 and 17 are also conceivable.

          Concluding, **Figure 30** shows that the connection to be created with the implant 7 according to the invention need not necessarily serve the connection of two elements (two tissue  
25 parts or a tissue part and an artificial part). It is also conceivable to use an implant according to the invention for filling a tissue opening 80 being caused by a tumour for example. For this advantageously an implant 7 of a highly viscous and thixotropic material 81 is used. With the aid of a guide 82 being positioned around the opening, this material is introduced into the opening 18 such that it projects beyond the opening. The resonator 6 used for this application has a cross  
30 section corresponding to the inner cross section of the guide 82 and presses the material 81 into the opening 80 like a piston. The opening 80 is thereby not only filled essentially without interstices, but the material 81 becoming liquid under the effect of ultrasound is also pressed into the tissue pores opening into the opening 80, and such forms a positive fit connection after solidification, which is shown below in Fig. 30. This positive-fit connection securely holds the  
35 implant 7 in its opening 80 even without the opening comprising undercuts, and without providing other retaining means (e.g. periosteum sutured above the implant).

          Suitably finely processed bone material of the patient may be admixed to the liquefiable material.

If in a case as shown in Fig. 30 a thermoplastic material is used instead of the thixotropic cement, the opening 80 may also be specially manufactured for accommodating a fixation element for a wire 84 or suture, as shown dot-dashed in Fig. 30 (only below). A therapeutic auxiliary device as for example a stimulator may be fixed in the same manner.

### Example 1

Pins of PLLA and polycarbonate manufactured by injection molding and having a round cross section of diameters between 3.5 and 4.25 mm, a length of 26 to 40 mm (ideal length at 20 kHz: 35mm), obtusely tapered, distal ends and four grooves axially extending over 10 mm from the distal end were anchored with an excitation frequency of 20 kHz in cancellous bone (femur head) of freshly slaughtered cattle. For implantation, the thin cortical substance layer lying over the cancellous bone was opened, but the cancellous bone was not predrilled. On implantation, the implants were pressed against the tissue with pressures of 60 to 130 N and excited with the excitation frequency (sonotrode amplitude approx. 20 to 25 $\mu$ m). The advance was limited to 10 mm which was achieved in less than 2 s. The implants were then held without excitation for 5 s.

The resulting anchorage depths were in the order of 15 mm and the anchorage on tearing out proved to be stronger than the implants themselves (maximum tear-out forces over 500 N). Sensors being placed at 1 mm from the prebore in the cortical bone substance (1.5 mm below the bone surface) recorded temperatures of max. 44°C (approx. 22° above room temperature) approx. 10 s after implantation. The temperature rise was reduced to half its value in approx. 30 seconds.

No molecular weight reduction was found in the implanted PLLA material when compared with the material before implantation.

**CLAIMS**

- 5 1. An implant for creating a positive-fit connection to a tissue part for connecting the tissue part with a further tissue part or with an artificial element replacing or supporting a further tissue part or being a therapeutic auxiliary device, characterized in that the implant at least partly consists of a material which is liquefiable by mechanical energy, wherein the liquefiable material is arranged on the implant in a manner such that it can be brought into contact with the tissue part  
10 and can be excited by mechanical oscillation and simultaneously be pressed against the tissue part for liquefying at least part of the liquefiable material and pressing it into openings of the tissue part.
2. The implant according to claim 1, characterized in that the liquefiable material is  
15 thermoplastic or thixotropic.
3. The implant according to either one of claims 1 or 2, characterized in that the liquefiable material comprises at least one resorbable component.
- 20 4. The implant according to any one of claims 1 to 3, characterized in that the liquefiable material further contains substances having further functions.
5. The implant according to any one of claims 1 to 4, characterized in that it has the shape of a pin or dowel.  
25
6. The implant according to claim 5, characterized in that the liquefiable material is arranged on the implant surface of a distal implant end and/or on cylindrical implant surfaces and that the implant comprises a core of a non-liquefiable material.
- 30 7. The implant according to claim 5, characterized in that it comprises a sleeve of a non-liquefiable material, that the liquefiable material is arranged in the inside of the sleeve and that the sleeve comprises openings for the exit of the liquefied material.
8. The implant according to claim 7, characterized in that the liquefiable material is  
35 resorbable and that the core or the sleeve has a surface of which at least a part is bioactive.
9. The implant according to any one of claims 4 to 8, characterized in that it comprises holding means arranged at a proximal implant end.



10. The implant according to any one of claims 1 to 4, characterized in that it has the shape of a plate or film.

11. The implant according to claim 10, characterized in that the plate or film is of one layer.

5

12. The implant according to claim 10, characterized in that the plate or film comprises a layer of the liquefiable material and a layer of a non-liquefiable material, wherein the liquefiable material covers at least a part of the one surface of the non-liquefiable material and the two layers are connected to one another by positive fit or material fit.

10

13. The implant according to any one of claims 1 to 12, characterized in that it is designed as an anchoring means for an artificial support or fixation element, for an artificial joint element, for an artificial tooth, bridge or tooth prosthesis, for a suture thread, for a cerclage wire or for a therapeutic auxiliary device.

15

14. An implantation device for implanting implants according to any one of claims 1 to 13 the device comprising a generator, an oscillation element and a resonator, wherein the generator is designed for exciting the oscillation element into mechanical oscillation, wherein the resonator and the oscillation element are connected to form an oscillation unit and wherein the resonator is actively connectable to the implant for transmission of the mechanical oscillations, and is designed for pressing the implant against a tissue part, characterized in that the device further comprises an implant guide which for being acoustically isolated is being supported on a housing.

20

25 15. The implantation device according to claim 14, characterized in that the device is designed for mechanical oscillations of the resonator with a frequency of 2 to 200 kHz.

16. The implantation device according to either one of claims 14 or 15, characterized in that the device is equipped for setting various frequencies of the mechanical oscillations, various frequency patterns and/or various energy pulsations.

30

17. The implantation device according to any one of claims 14 to 16, characterized in that the resonator or a distal part of the resonator is exchangeable and able to be sterilized.

35 18. The implantation device according to any one of claims 14 to 17, characterized in that the resonator is designed for holding a pin-like or dowel-like implant.

19. A kit for creating connections to tissue parts, said kit comprising an implantation device comprising a generator, an oscillation element and a resonator, wherein the generator is designed for exciting the oscillation element into mechanical oscillation, wherein the resonator and the oscillation element are connected to form an oscillation unit and wherein the resonator is actively connectable to the implant for transmission of the mechanical oscillations, and is designed for pressing the implant against a tissue part and said kit further comprising a plurality of implants according to any one of claims 1 to 13.
20. The kit according to claim 19, characterized in that the resonator of the implantation device comprises holding means at its distal end and that the implants are pin-like or dowel-like and their proximal end comprises holding means adapted to the holding means of the resonator.
21. The kit according to either one of the claims 19 or 20, characterized in that it comprises various pin-like or dowel-like implants as well as resonators or distal resonator parts, whose distal surfaces correspond to the proximal cross sections of the implants.
22. The kit according to any one of claims 19 to 21, characterized in that at least a part of the implants is pin-like and that the kit further comprises drills whose diameter is adapted to the largest diameter of the implants for a friction fit.
23. The kit according to any one of claims 19 to 22, characterized in that at least a part of the implants comprises the liquefiable material in a sleeve having openings and that the kit further comprises at least one resonator or distal resonator part, which in its cross section is adapted to the proximal inner cross section of the sleeve.
24. The kit according to any one of claims 19 to 23, characterized in that the kit further comprises guides with an opening, and at least one resonator or distal resonator part, which in its cross section is adapted to the opening.
25. The kit according to any one of claims 19 to 24, characterized in that it further comprises sterile coverings for the implantation device.
26. The kit according to any one of claims 19 to 25, characterized in that the implantation device is equipped for setting various oscillation frequencies, various frequency patterns and/or various energy pulsations and that the kit further comprises setting instructions for various implants.

27. An addition kit with one or more implants according to any one of claims 1 to 13, said addition kit further comprising instructions for implanting the implants with the help of mechanical oscillation energy.

5 28. An implant according to any one of claims 1 to 13 for use in a method of implantation with the help of an implantation device comprising a generator, an oscillation element and a resonator, wherein the generator is designed for exciting the oscillation element into mechanical oscillation, wherein the resonator and the oscillation element are connected to form an oscillation unit and wherein the resonator is actively connectable to the implant for transmission of the  
10 mechanical oscillations, and is designed for pressing the implant against a tissue part, the method comprising the steps of:

- positioning the implant on the tissue part in a manner such that implant regions of the liquefiable material are in contact or can be brought into contact with the tissue part in a region in which the tissue part has surface unevennesses or  
15 openings suitable as a positive fit means or in which such surface unevennesses or openings can be created by hydrostatic pressure,
- impinging the implant with mechanical oscillation and simultaneously pressing the implant against the tissue part until at least a part of the liquefiable material is liquefied and is pressed into said surface unevennesses or openings,
- 20 ▪ letting the liquefiable material resolidify, while still pressing the implant against the tissue part.

29. The implant according to claim 28, characterized in that the tissue part is a human or animal bone part, cartilage part, ligament part or tendon part.

25 30. The implant according to either one of claims 28 or 29, characterized in that the connection to be created is a pointwise, depth-effective connection.

31. The implant according to any one of claims 28 to 30, characterized in that an opening is  
30 created in the tissue part before implantation, the implant being positioned in the opening.

32. The implant according to any one of claims 28 to 31, characterized in that the tissue part is a bone with cortical bone substance and cancellous bone and that before implantation at least the cortical layer is opened.

35 33. The implant according to either one of claims 28 or 29, characterized in that the connection to be created is a large-surfaced, superficial connection.

34. The implant according to claim 33, characterized in that suitable tissue surface regions are roughened before positioning the implant.
35. An implant substantially as herein described and illustrated.