



US00D680630S

(12) **United States Design Patent**  
**Beagen, Jr.**

(10) **Patent No.:** **US D680,630 S**

(45) **Date of Patent:** **\*\* Apr. 23, 2013**

(54) **SLIP-ON COUPLING ASSEMBLY**

(75) Inventor: **Joseph William Beagen, Jr.**,  
Providence, RI (US)

(73) Assignee: **Mueller International, LLC**, Atlanta,  
GA (US)

(\*\*) Term: **14 Years**

(21) Appl. No.: **29/406,887**

(22) Filed: **Nov. 21, 2011**

(51) **LOC (9) Cl.** ..... **23-01**

(52) **U.S. Cl.**  
USPC ..... **D23/262**

(58) **Field of Classification Search** ..... D23/262,  
D23/259; 239/428.5; 261/DIG. 22; D8/396;  
285/1, 112, 179, 340, 367, 373, 404, 53,  
285/915; 403/291, 300; 411/5, 10; 137/801  
See application file for complete search history.

(56) **References Cited**

U.S. PATENT DOCUMENTS

29,731 A	8/1860	Truss
815,581 A	3/1906	Dean
1,006,294 A	10/1911	Schubart
1,093,868 A	4/1914	Leighty
1,352,918 A	9/1920	Rohbock
1,541,601 A	6/1925	Tribe
1,851,574 A	3/1929	Fiederlein
1,833,776 A	11/1931	Dillon
1,867,891 A	7/1932	Reynolds
1,881,508 A	10/1932	Gredell
1,930,194 A	10/1933	Dillon
1,937,881 A	12/1933	Fisher
1,970,078 A	8/1934	Dillon
1,987,235 A	1/1935	Janeway
2,020,156 A	11/1935	Muchnic
2,041,132 A	5/1936	Johnson
2,369,770 A	2/1945	Baxter

2,377,510 A	6/1945	Newell
2,439,979 A	4/1948	Krooss
2,449,795 A	9/1948	Stillwagon
2,456,048 A	12/1948	Carpenter
2,473,046 A	6/1949	Adams
2,473,102 A	6/1949	Krooss
2,486,120 A	10/1949	Colton et al.
2,616,946 A	11/1952	Scheer

(Continued)

FOREIGN PATENT DOCUMENTS

DE	1051585	2/1959
DE	972484	7/1959

(Continued)

OTHER PUBLICATIONS

Beagen Jr.; U.S. Patent Application Entitled: Slip-on Coupling; U.S. Appl. No. 13/354,459, filed Jan. 20, 2012; 33 pages.

(Continued)

*Primary Examiner* — Eric Goodman

(74) *Attorney, Agent, or Firm* — Taylor English Duma LLP

(57) **CLAIM**

I claim the ornamental design for a slip-on coupling assembly, as shown and described.

**DESCRIPTION**

FIG. 1 is a perspective view of a slip-on coupling assembly of the design described herein.  
FIG. 2 is a left side view thereof.  
FIG. 3 is a right side view thereof.  
FIG. 4 is a front side view thereof.  
FIG. 5 is a top side view thereof.  
FIG. 6 is a bottom side view thereof; and,  
FIG. 7 is a sectional view thereof taken along the line 7-7 as shown in FIG. 4.

**1 Claim, 5 Drawing Sheets**

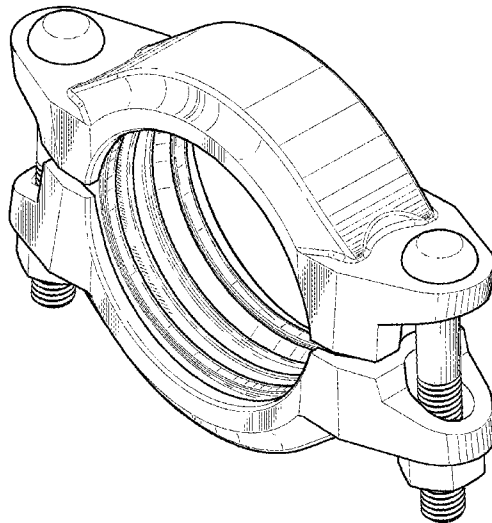

# US D680,630 S

Page 2

U.S. PATENT DOCUMENTS					
2,675,253 A	4/1954	Stade	4,522,433 A	6/1985	Valentine et al.
2,688,170 A	9/1954	Balzer	4,522,434 A	6/1985	Webb
2,688,500 A	9/1954	Scott	4,568,115 A	2/1986	Zimmerly
2,752,173 A	6/1956	Krooss	4,601,495 A	7/1986	Webb
2,754,136 A	7/1956	Newton	4,611,839 A	9/1986	Rung et al.
2,816,780 A	12/1957	Ross	4,616,858 A	10/1986	Sauer
2,821,415 A	1/1958	Race	4,629,217 A	12/1986	Straub
2,944,839 A	7/1960	Anderson	4,639,020 A	1/1987	Rung et al.
3,003,793 A	10/1961	Pitt	4,643,461 A	2/1987	Thau, Jr. et al.
3,004,781 A	10/1961	Morris	D289,078 S	3/1987	Vassallo et al.
3,014,259 A	12/1961	Joseph	4,702,499 A	10/1987	deRaymond et al.
3,015,502 A	1/1962	Frost et al.	4,702,500 A	10/1987	Thau, Jr. et al.
3,024,046 A	3/1962	Frost et al.	4,717,299 A	1/1988	Underwood
D196,724 S	10/1963	Davis	4,722,561 A	2/1988	Heckethorn et al.
3,107,108 A	10/1963	Greene	4,726,611 A	2/1988	Sauer
3,135,154 A	6/1964	Zenzic	4,739,542 A	4/1988	Krzesicki
3,153,550 A	10/1964	Hollett	4,776,362 A	10/1988	Domingue, Sr. et al.
3,176,723 A	4/1965	Hodgeman et al.	4,861,075 A	8/1989	Pepi et al.
3,181,896 A	5/1965	Russell	4,893,843 A	1/1990	DeRaymond
3,189,969 A	6/1965	Sweet	4,896,902 A	1/1990	Weston
3,201,149 A	8/1965	Bragg	4,915,418 A	4/1990	Palatchy
3,207,538 A	9/1965	Pattillo	4,966,395 A	10/1990	Hendrickson
3,213,817 A	10/1965	Kish	5,018,548 A	5/1991	McLennan
3,283,553 A	11/1966	Taylor	5,037,141 A	8/1991	Jardine
3,285,568 A	11/1966	Biach	5,039,137 A	8/1991	Cankovic et al.
3,291,506 A	12/1966	Blakeley	5,056,833 A	10/1991	Webb et al.
3,298,698 A	1/1967	Condon	5,058,931 A	10/1991	Bowsher
3,313,197 A	4/1967	Knohl	5,080,400 A	1/1992	Adamek et al.
3,315,970 A	4/1967	Holoway	5,094,492 A	3/1992	Levivier
3,329,446 A	7/1967	Katis et al.	5,104,153 A	4/1992	Corcoran
3,351,352 A	11/1967	Blakeley et al.	5,137,305 A	8/1992	Straub
3,362,730 A	1/1968	St. Clair et al.	5,190,324 A	3/1993	Bird et al.
3,386,771 A	6/1968	Verdier et al.	5,203,594 A	4/1993	Straub
3,425,473 A	2/1969	Knowlton	5,230,537 A	7/1993	Newman
3,464,722 A	9/1969	Larkin	5,230,540 A	7/1993	Lewis et al.
3,524,662 A	8/1970	Tolman et al.	5,240,294 A	8/1993	Corcoran
3,550,638 A	12/1970	Smith	5,246,256 A	9/1993	Rung et al.
3,658,367 A	4/1972	Pfeuffer	5,246,257 A	9/1993	Kojima et al.
3,664,691 A	5/1972	Nakamura	5,248,169 A	9/1993	Barbe et al.
3,680,619 A	8/1972	Sparks	5,249,829 A	10/1993	Hendrickson
3,680,894 A	8/1972	Young	5,273,322 A	12/1993	Straub
3,695,638 A	10/1972	Blakeley	5,280,969 A	1/1994	Straub
RE27,736 E	8/1973	Muhlner et al.	5,280,970 A	1/1994	Straub
3,794,361 A	2/1974	Westberg	5,291,769 A	3/1994	Miyano
3,797,078 A	3/1974	LaPointe	5,301,986 A	4/1994	Yehezkeili
3,807,435 A	4/1974	Fenster et al.	5,306,021 A	4/1994	Morvant
3,856,245 A	12/1974	Byerly	5,312,137 A	5/1994	Nee
3,877,733 A	4/1975	Straub	5,351,997 A	10/1994	Webb et al.
3,905,623 A	9/1975	Cassel	5,354,108 A	10/1994	Sandor
3,966,237 A	6/1976	Thiessen	5,387,017 A	2/1995	Gill
3,977,705 A	8/1976	Thiessen et al.	5,450,738 A	9/1995	Chatterley et al.
4,034,788 A	7/1977	Melone	5,508,931 A	4/1996	Snider
4,064,921 A	12/1977	Kose	5,509,702 A	4/1996	Warehime et al.
4,108,479 A	8/1978	Straub	5,560,656 A	10/1996	Okamura et al.
4,109,941 A	8/1978	Wood et al.	5,603,508 A	2/1997	Dole et al.
4,111,234 A	9/1978	Wells et al.	5,651,588 A	7/1997	Kato
4,114,414 A	9/1978	Goodman	5,658,021 A	8/1997	Matsumoto et al.
4,131,302 A	12/1978	Leonard, Jr.	5,697,650 A	12/1997	Brown
4,137,610 A	2/1979	Hoen	5,758,906 A	6/1998	Carlstrom et al.
4,176,865 A	12/1979	Felton et al.	5,758,907 A	6/1998	Dole et al.
D256,046 S	7/1980	Perrin	5,772,257 A	6/1998	Webb et al.
4,258,361 A	3/1981	Hydes et al.	5,778,715 A	7/1998	Lippka et al.
4,258,941 A	3/1981	Sands	5,845,384 A	12/1998	Retzbach
4,304,415 A	12/1981	Wolf et al.	5,873,611 A	2/1999	Munley et al.
4,311,248 A	1/1982	Westerlund et al.	5,899,507 A	5/1999	Schroeder et al.
4,326,737 A	4/1982	Lehmann	5,901,601 A	5/1999	Fujimoto et al.
4,350,350 A	9/1982	Blakeley	5,911,446 A	6/1999	McLennan et al.
4,377,894 A	3/1983	Yoshida	5,971,001 A	10/1999	Andersson
4,391,458 A	7/1983	Blakeley	6,070,911 A	6/2000	Namikawa et al.
4,403,378 A	9/1983	Engman	6,070,914 A	6/2000	Schmidt
4,408,788 A	10/1983	Beukema	6,076,861 A	6/2000	Ikeda
4,417,755 A	11/1983	Gittleman	6,139,069 A	10/2000	Radzik
4,432,558 A	2/1984	Westerlund et al.	6,142,536 A	11/2000	Wolfsdorf
4,438,958 A	3/1984	De Cenzo	6,170,884 B1	1/2001	McLennan et al.
4,471,979 A	9/1984	Gibb et al.	6,171,039 B1	1/2001	Seurujarvi
4,480,861 A	11/1984	Cann, Jr.	6,206,434 B1	3/2001	Schreiter
4,506,418 A	3/1985	Viola et al.	6,227,577 B1	5/2001	Ikeda et al.
4,518,177 A	5/1985	Deakins	6,231,286 B1	5/2001	Bogatz et al.
			6,302,450 B1	10/2001	Dole et al.



WO	2005114024	12/2005
WO	WO 2007145995	12/2007
WO	WO 2008104792	4/2008

## OTHER PUBLICATIONS

Beagen Jr.; U.S. Patent Application Entitled: Coupling with Tongue and Groove; U.S. Appl. No. 13/354,464, filed Jan. 20, 2012; 32 pages.  
 Beagen Jr.; U.S. Patent Application Entitled: Coupling Gasket with Multiple Sealing Surfaces; U.S. Appl. No. 13/354,466, filed Jan. 20, 2012; 32 pages.

Beagen Jr.; U.S. Patent Application Entitled: Slip-on Coupling Gasket; U.S. Appl. No. 13/354,470, filed Jan. 20, 2012; 32 pages.

Beagen Jr.; U.S. Patent Application Entitled: Slip-on Coupling Segment; U.S. Appl. No. 29/406,886, filed Nov. 21, 2011; 5 pages.

Beagen Jr.; U.S. Patent Application Entitled: Slip-on Gasket; U.S. Appl. No. 29/405,039, filed Oct. 27, 2011; 3 pages.

Vandal.; U.S. Patent Application Entitled: Slip On Groove Coupling with Multiple Sealing Gasket; U.S. Appl. No. 12/490,113, filed Jun. 23, 2009; 33 pages.

Vandal; U.S. Patent Application Entitled: Slip On Groove Coupling with Multiple Sealing Gasket; U.S. Appl. No. 13/300,718, filed Nov. 21, 2011; 29 pages.

Vandal; Canadian Patent Application Entitled: Slip On Groove Coupling with Multiple Sealing Gasket; Ser. No. 2,732,427, filed Jun. 25, 2009; 36 pages.

Vandal; PCT Application Entitled: Slip On Groove Coupling with Multiple Sealing Gasket; U.S. Appl. No. PCT/US09/48637, filed Jun. 25, 2009; 33 pages.

Vandal; U.S. Provisional Patent Application Entitled: Slip On Groove Coupling with Multiple Sealing Gasket, U.S. Appl. No. 61/133,300, filed Jun. 30, 2008; 9 pages.

Gibb, John; Request for Inter Partes Reexamination under U.S. Appl. No. 95/001,878, filed Jan. 27, 2012; 36 pages.

Gibb, John; Request for Inter Partes Reexamination under U.S. Appl. No. 95/001,880, filed Feb. 1, 2012; 271 pages.

Vandal, Peter; Office Action from Canadian Intellectual Property Office for Application No. 2,732,427, filed Jun. 25, 2009, mailed Jul. 5, 2012; 4 pgs.

Vandal; Notice of Allowance for U.S. Appl. No. 12/490,113, filed Jun. 23, 2009, mailed May 31, 2012; 9 pgs.

Vandal; Notice of Allowance for U.S. Appl. No. 12/490,113, filed Jun. 23, 2009, mailed Apr. 16, 2012; 6 pgs.

Vandal; Notice of Allowance for U.S. Appl. No. 12/490,113, filed Jun. 23, 2009, mailed Feb. 29, 2012; 39 pgs.

Vandal; Restriction Requirement for U.S. Appl. No. 12/490,113, filed Jun. 23, 2009, mailed Oct. 26, 2011; 5 pgs.

Vandal; Non-Final Office Action for U.S. Appl. No. 12/490,113, filed Jun. 23, 2009, mailed Dec. 8, 2011, 13 pages.

Vandal; International Search Report and Written Opinion for U.S. Appl. No. PCT/US09/48637, filed Jun. 25, 2009, mailed Jan. 4, 2010; 15 pages.

Vandal; International Search Report and Written Opinion for U.S. Appl. No. PCT/US09/48291, filed Jun. 23, 2009, mailed Apr. 2, 2010; 11 pages.

Gibb, John; Request for Ex Parte Reexamination under U.S. Appl. No. 90/012,656, filed Sep. 14, 2012; 143 pages.

Gibb, John; Request for Inter Partes Reexamination under U.S. Appl. No. 95/002,401, filed Sep. 15, 2012; 147 pages.

Gibb, John; Request for Inter Partes Reexamination under U.S. Appl. No. 95/002,410, filed Sep. 15, 2012; 85 pages.

Beagan Jr.; Notice of Allowance for U.S. Appl. No. 29/406,886, filed Nov. 21, 2011, mailed Dec. 6, 2012; 50 pgs.

Beagen Jr, Joseph William; Supplemental Notice of Allowance for U.S. Appl. No. 29/406,886, filed Nov. 21, 2011, mailed Jan. 10, 2013; 13 pgs.

Vandal, Peter Joseph; Non-Final Office Action for U.S. Appl. No. 13/554,721, filed Jul. 20, 2012, mailed Feb. 5, 2013; 54 pgs.

\* cited by examiner

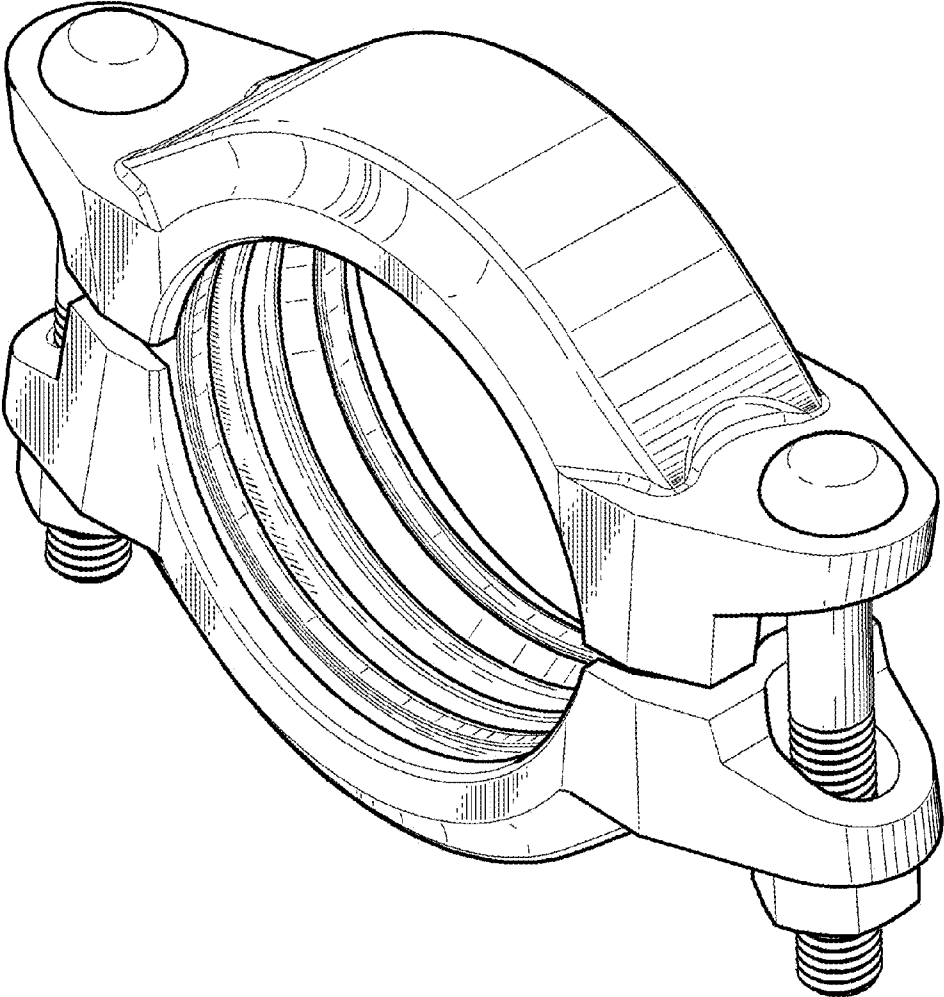
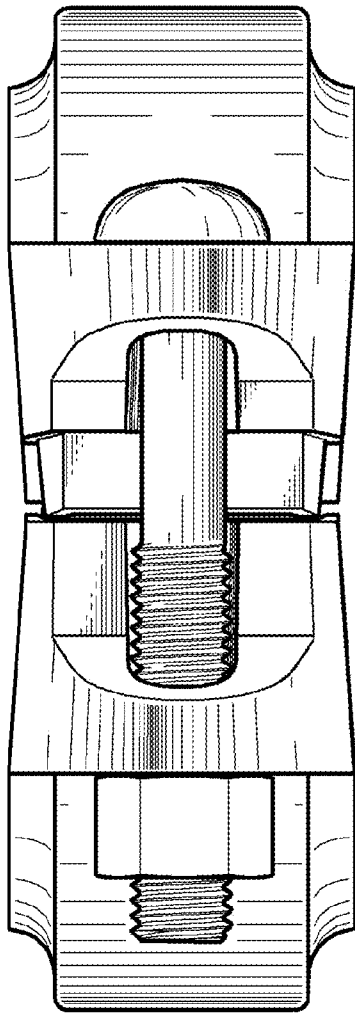
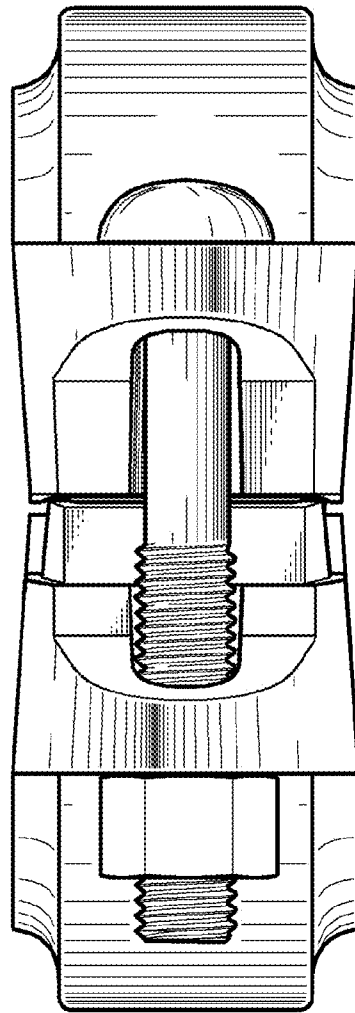

FIG. 1



**FIG. 2**



**FIG. 3**

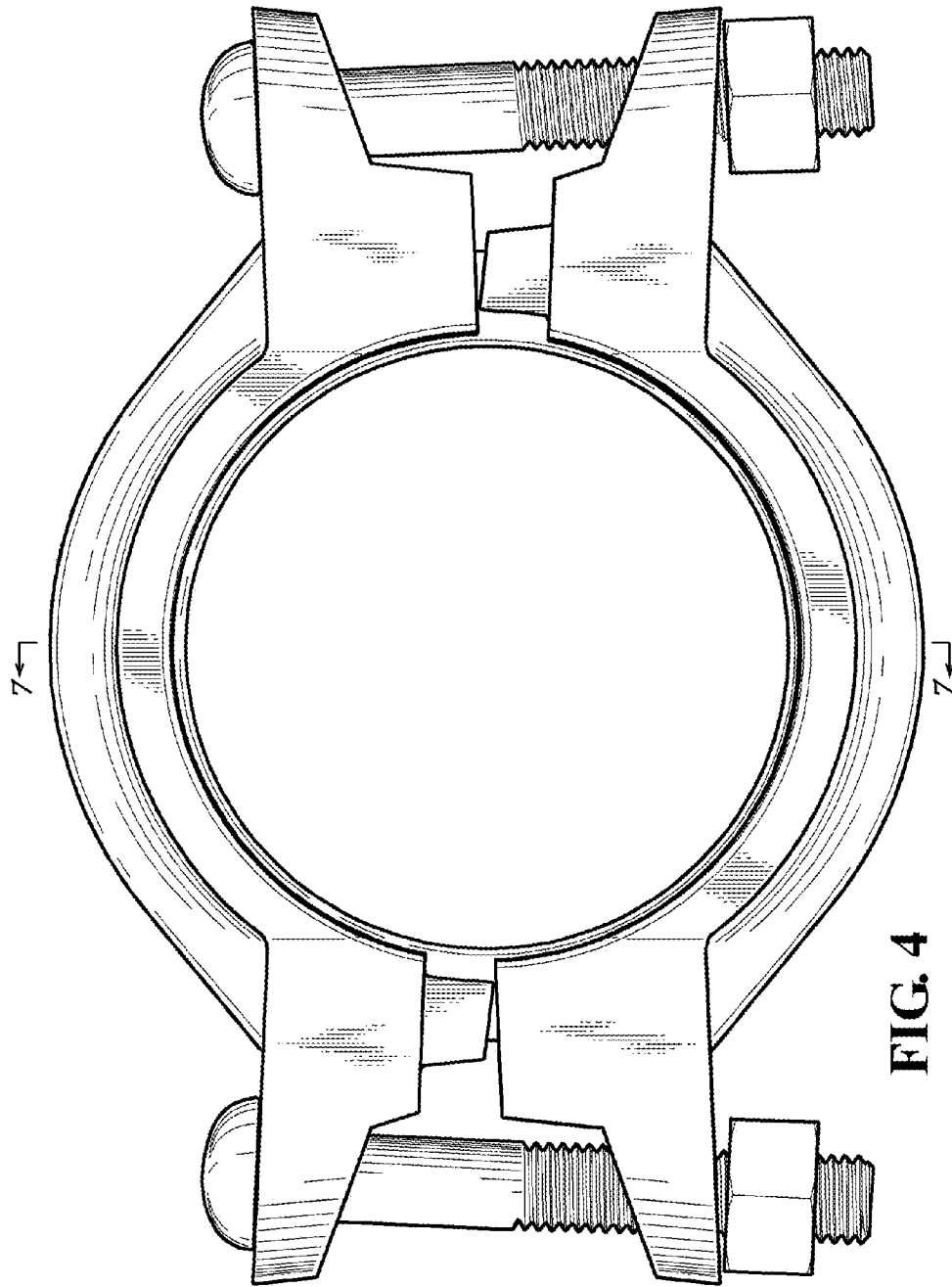

FIG. 4

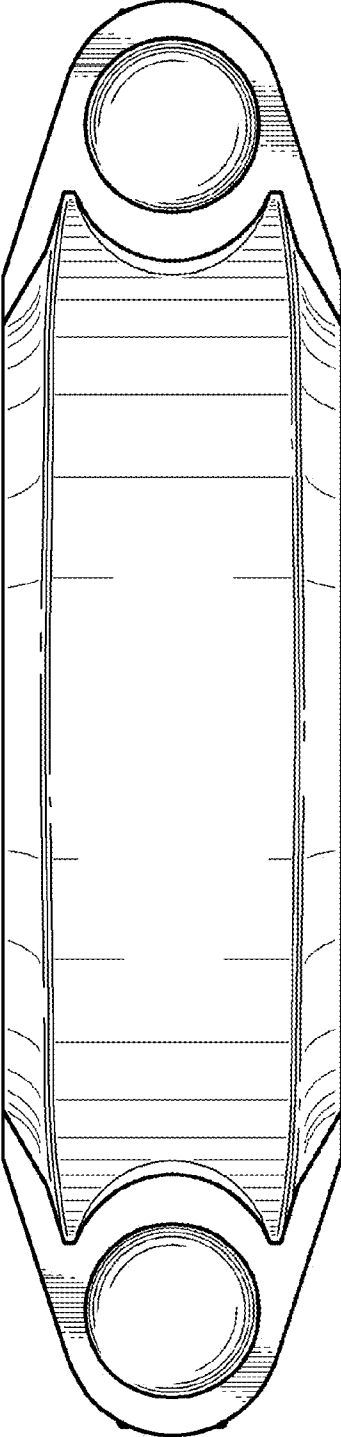

FIG. 5

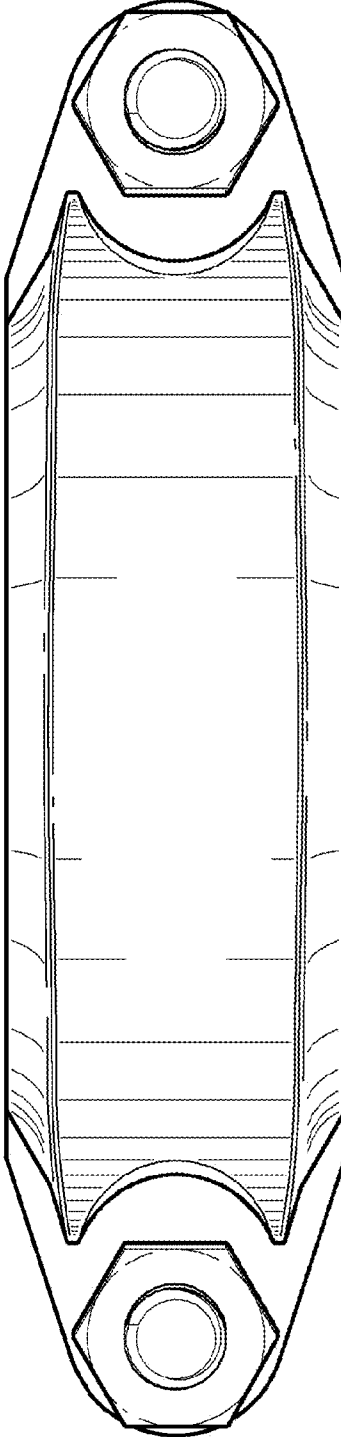

FIG. 6



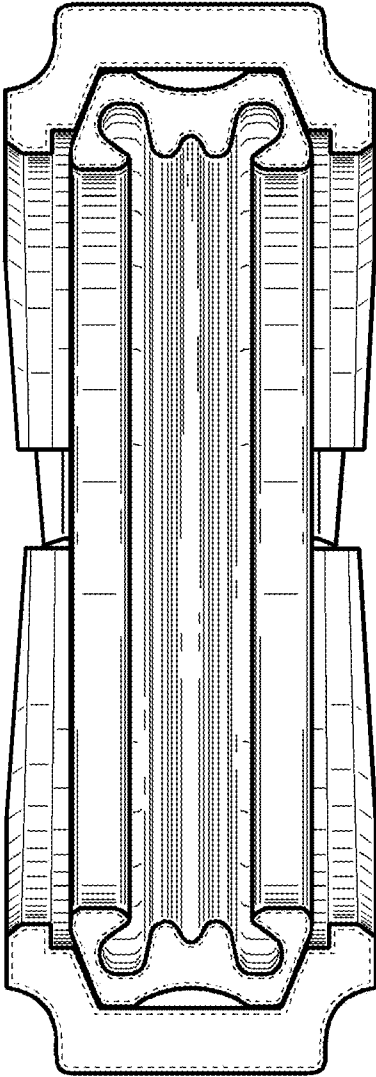

FIG. 7