



US00D911857S

(12) **United States Design Patent**
King et al.

(10) **Patent No.:** **US D911,857 S**

(45) **Date of Patent:** **** Mar. 2, 2021**

(54) **SENSOR ENHANCED PARKING METER**
(71) Applicant: **IPS Group Inc.**, San Diego, CA (US)
(72) Inventors: **David William King**, Rancho Santa Fe, CA (US); **Andre Malan Joubert**, Edenvale (ZA); **David Andrew Jones**, Beecroft (AU); **Choor-Hong Tan**, Epping (AU); **Abigail Maude Thomas**, Dulwich Hill (AU)

2,832,506 A 4/1958 Hatcher
D189,106 S 10/1960 Leiderman
2,988,191 A 6/1961 Grant
D199,270 S 9/1964 Michales
(Continued)

FOREIGN PATENT DOCUMENTS

CA 2377010 A1 10/2001
CA 2363915 A1 5/2003
(Continued)

(73) Assignee: **IPS GROUP INC.**, San Diego, CA (US)

OTHER PUBLICATIONS

Cell Net Data Systems. First Wireless Monitoring of Parking Meters Results in Theft Arrests Using CellNet Data Systems Technology. PRNewswire (May 11, 1999) (2 pgs.).
(Continued)

(**) Term: **15 Years**

Primary Examiner — Katherine Glennon
(74) *Attorney, Agent, or Firm* — Wilson Sonsini Goodrich & Rosati

(21) Appl. No.: **29/680,837**

(22) Filed: **Feb. 20, 2019**

(51) **LOC (13) Cl.** **10-03**

(52) **U.S. Cl.**
USPC **D10/42**

(58) **Field of Classification Search**
USPC D10/40-42, 46, 49; D13/162, 162.1, D13/164, 177
CPC G07B 15/02; G07F 17/00; G07F 15/248; G07F 9/10; H04Q 2209/886
See application file for complete search history.

(57) **CLAIM**
The ornamental design for a sensor enhanced parking meter, as shown and described.

DESCRIPTION

FIG. 1 is a top right front perspective view of a sensor enhanced parking meter, showing our new design; FIG. 2 is a top left rear perspective view thereof; FIG. 3 is a bottom right rear perspective view thereof; FIG. 4 is a front elevational view thereof; FIG. 5 is a rear elevational view thereof; FIG. 6 is a left side elevational view thereof; FIG. 7 is a right side elevational view thereof; and, FIG. 8 is a top plan view thereof. The structural features depicted by broken lines have been shown for the purpose of illustrating environment that forms no part of the claimed design.

(56) **References Cited**

U.S. PATENT DOCUMENTS

D98,810 S 3/1936 Carl
D107,577 S 12/1937 McGay et al.
2,161,046 A 6/1939 Hitzeman
D116,805 S 9/1939 Ben
2,229,183 A 1/1941 Mitchell
D162,698 S 3/1951 James
D166,059 S 2/1952 Adolph et al.
D166,753 S 5/1952 Whitney
2,596,124 A 5/1952 Broussard
D181,359 S 11/1957 Whitney
2,822,682 A 2/1958 Sollenberger

1 Claim, 8 Drawing Sheets

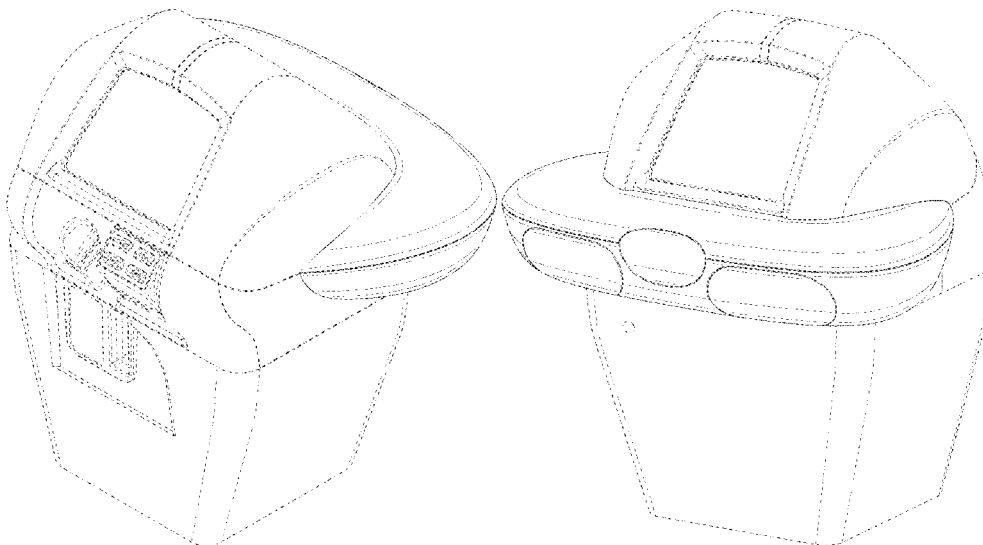

(56)

References Cited

U.S. PATENT DOCUMENTS

D200,216	S	2/1965	Broussard	6,505,774	B1	1/2003	Fulcher et al.
3,183,411	A	5/1965	Palfi et al.	6,559,776	B2	5/2003	Katz et al.
3,486,324	A	12/1969	Andersson	6,697,730	B2	2/2004	Dickerson
3,535,870	A	10/1970	Mitchell et al.	6,747,575	B2	6/2004	Chauvin et al.
3,721,463	A	3/1973	Attwood et al.	D498,795	S	11/2004	Nunn
3,999,372	A	12/1976	Welch et al.	6,812,857	B1	11/2004	Kassab et al.
4,031,991	A	6/1977	Malott	6,856,922	B1	2/2005	Austin et al.
4,043,117	A	8/1977	Maresca et al.	6,874,340	B1	4/2005	Berman
4,310,890	A	1/1982	Trehn et al.	6,885,311	B2	4/2005	Howard et al.
4,460,965	A	7/1984	Trehn et al.	6,889,899	B2	5/2005	Silberberg
4,812,805	A	3/1989	Lachat et al.	D506,509	S	6/2005	Nunn
4,823,928	A	4/1989	Speas	6,914,411	B2	7/2005	Couch et al.
4,825,425	A	4/1989	Turner	6,929,179	B2	8/2005	Fulcher et al.
4,875,598	A	10/1989	Dahl	6,946,974	B1	9/2005	Racunas, Jr.
4,880,097	A	11/1989	Speas	7,019,420	B2	3/2006	Kogan et al.
4,895,238	A	1/1990	Speas	7,019,670	B2	3/2006	Bahar
D319,077	S	8/1991	Arato et al.	7,023,360	B2	4/2006	Staniszewski et al.
5,065,156	A	11/1991	Bernier	7,027,773	B1	4/2006	McMillin
5,155,614	A	10/1992	Carmen et al.	7,029,167	B1	4/2006	Mitschele
5,201,396	A	4/1993	Chalabian et al.	7,183,999	B2	2/2007	Matthews et al.
5,222,076	A	6/1993	Ng et al.	D543,588	S	5/2007	Herbert et al.
5,244,070	A	9/1993	Carmen et al.	7,222,031	B2	5/2007	Heatley
5,273,151	A	12/1993	Carmen et al.	7,237,716	B2	7/2007	Silberberg
5,360,095	A	11/1994	Speas	7,388,349	B2	6/2008	Elder et al.
5,426,363	A	6/1995	Akagi et al.	7,391,339	B2	6/2008	Howard et al.
5,442,348	A	8/1995	Mushell et al.	D575,168	S	8/2008	King et al.
5,471,139	A	11/1995	Zadoff et al.	D587,141	S *	2/2009	King D10/42
5,563,491	A	10/1996	Tseng	7,748,620	B2	7/2010	Gomez et al.
5,614,892	A	3/1997	Ward, II et al.	7,772,720	B2	8/2010	McGee et al.
5,617,942	A	4/1997	Ward, II et al.	7,783,530	B2	8/2010	Slemmer et al.
5,640,002	A	6/1997	Ruppert et al.	7,806,248	B2	10/2010	Hunter et al.
5,642,119	A	6/1997	Jacobs et al.	7,825,826	B2	11/2010	Welch et al.
5,648,906	A	7/1997	Amirpanahi	7,854,310	B2 *	12/2010	King G06Q 20/34 194/350
5,659,306	A	8/1997	Bahar	7,855,661	B2	12/2010	Ponert
D388,231	S	12/1997	Magee et al.	D635,035	S *	3/2011	Matsumoto D10/41
5,710,743	A	1/1998	Dee et al.	7,933,841	B2	4/2011	Schmeyer et al.
5,732,812	A	3/1998	Grainger et al.	D654,816	S	2/2012	MacKay et al.
D393,212	S	4/1998	Lucas	D656,046	S	3/2012	MacKay et al.
5,737,710	A	4/1998	Anthonyson	8,138,950	B1	3/2012	Leung
5,777,951	A	7/1998	Mitschele et al.	D661,603	S	6/2012	MacKay et al.
5,778,067	A	7/1998	Jones et al.	8,279,107	B2	10/2012	Krstanovic et al.
5,805,083	A	9/1998	Sutton et al.	8,395,532	B2	3/2013	Chauvin et al.
5,806,651	A	9/1998	Carmen et al.	D683,794	S	6/2013	Randall
D400,115	S	10/1998	Yaron et al.	8,479,909	B2	7/2013	King et al.
5,833,042	A	11/1998	Baitch et al.	8,513,832	B2	8/2013	Hunter et al.
5,841,369	A	11/1998	Sutton et al.	D690,771	S *	10/2013	Randall D20/9
5,842,411	A	12/1998	Johnson	8,566,159	B2	10/2013	King et al.
5,845,268	A	12/1998	Moore et al.	D692,784	S	11/2013	Anderssen et al.
5,852,411	A	12/1998	Jacobs et al.	8,590,687	B2	11/2013	King et al.
D412,289	S	7/1999	Winwood	8,595,054	B2	11/2013	King et al.
5,954,182	A	9/1999	Wei	8,631,921	B2	1/2014	Jones et al.
5,966,345	A	10/1999	Dee et al.	8,684,158	B2	4/2014	Jones et al.
6,037,880	A	3/2000	Manion	D705,090	S *	5/2014	MacKay D10/42
6,078,272	A	6/2000	Jacobs et al.	D707,140	S	6/2014	King et al.
6,081,205	A	6/2000	Williams et al.	D707,141	S *	6/2014	King D10/42
6,109,418	A	8/2000	Yost	D707,142	S *	6/2014	King D10/42
6,111,522	A	8/2000	Hiltz et al.	8,749,403	B2	6/2014	King et al.
6,116,403	A	9/2000	Kiehl	8,770,371	B2	7/2014	MacKay et al.
6,195,015	B1	2/2001	Jacobs et al.	D716,157	S *	10/2014	MacKay D10/42
D439,591	S	3/2001	Reidt et al.	8,862,494	B2	10/2014	King et al.
RE37,193	E	5/2001	Ward, II et al.	8,884,785	B2	11/2014	Groft et al.
6,229,455	B1	5/2001	Yost et al.	9,002,723	B2	4/2015	King et al.
6,230,868	B1	5/2001	Tuxen et al.	9,047,712	B2	6/2015	King et al.
6,243,028	B1	6/2001	Krygler et al.	9,127,964	B2	9/2015	Schwarz et al.
D447,714	S	9/2001	Cappiello	D749,000	S *	2/2016	King D10/42
D449,010	S	10/2001	Petrucelli	D750,513	S	3/2016	King et al.
6,309,098	B1	10/2001	Wong	D755,650	S *	5/2016	King D10/42
6,312,152	B2	11/2001	Dee et al.	D756,807	S *	5/2016	King D10/42
RE37,531	E	1/2002	Chaco et al.	D756,808	S *	5/2016	King D10/42
D454,807	S	3/2002	Cappiello	9,391,474	B2	7/2016	Hunter et al.
6,373,422	B1	4/2002	Mostafa	9,424,691	B2	8/2016	King et al.
D461,728	S	8/2002	Tuxen et al.	9,489,776	B2	11/2016	Kell et al.
6,456,491	B1	9/2002	Flannery et al.	9,508,198	B1 *	11/2016	King G07C 1/30
D463,749	S	10/2002	Petrucelli	9,652,921	B2 *	5/2017	MacKay G07F 17/248
6,457,586	B2	10/2002	Yasuda et al.	9,661,403	B2	5/2017	King et al.
				9,685,027	B2	6/2017	King et al.
				9,728,085	B2	8/2017	Schwarz et al.
				D799,992	S *	10/2017	Ehara D10/41

(56)

References Cited

U.S. PATENT DOCUMENTS

9,805,518 B2 10/2017 King et al.
 10,262,345 B2 4/2019 King et al.
 10,297,150 B2 5/2019 Schwarz et al.
 10,299,018 B1* 5/2019 King H04Q 9/00
 D851,605 S* 6/2019 Maetani DI3/162
 2001/0047278 A1 11/2001 Brookner et al.
 2001/0051531 A1 12/2001 Singhal et al.
 2002/0008639 A1 1/2002 Dee
 2002/0111768 A1 8/2002 Ghorayeb et al.
 2003/0092387 A1 5/2003 Hjelmvik
 2003/0112597 A1 6/2003 Smith
 2003/0121754 A1 7/2003 King
 2003/0128010 A1 7/2003 Hsu
 2003/0128136 A1 7/2003 Spier et al.
 2003/0140531 A1 7/2003 Pippins
 2003/0144972 A1 7/2003 Cordery et al.
 2003/0169183 A1 9/2003 Korepanov et al.
 2003/0179107 A1 9/2003 Kibria et al.
 2003/0220835 A1 11/2003 Barnes et al.
 2003/0222792 A1 12/2003 Berman et al.
 2004/0068434 A1 4/2004 Kanekon
 2004/0084278 A1 5/2004 Harris et al.
 2004/0181496 A1 9/2004 Odinotski et al.
 2004/0264302 A1 12/2004 Ward
 2005/0040951 A1 2/2005 Zalewski et al.
 2005/0099320 A1 5/2005 Nath et al.
 2005/0178639 A1 8/2005 Brumfield et al.
 2005/0192911 A1 9/2005 Mattern
 2005/0226201 A1 10/2005 McMillin et al.
 2006/0021848 A1 2/2006 Smith
 2006/0116972 A1 6/2006 Wong
 2006/0136131 A1 6/2006 Dugan et al.
 2006/0149684 A1 7/2006 Matsuura et al.
 2006/0152349 A1 7/2006 Ratnakar
 2006/0267799 A1 11/2006 Mendelson
 2007/0016539 A1 1/2007 Groft et al.
 2007/0040449 A1 2/2007 Spurlin et al.
 2007/0074702 A1 4/2007 Nakamura et al.
 2007/0094153 A1 4/2007 Ferraro
 2007/0114849 A1 5/2007 Falik et al.
 2007/0119682 A1 5/2007 Banks et al.
 2007/0136128 A1 6/2007 Janacek et al.
 2007/0184852 A1 8/2007 Johnson et al.
 2007/0189907 A1 8/2007 Kunihiro et al.
 2007/0210935 A1 9/2007 Yost et al.
 2008/0052254 A1 2/2008 Al et al.
 2008/0071611 A1 3/2008 Lovett
 2008/0093454 A1 4/2008 Yamazaki et al.
 2008/0147268 A1 6/2008 Fuller
 2008/0208680 A1 8/2008 Cho
 2008/0238715 A1 10/2008 Cheng et al.
 2009/0109062 A1 4/2009 An
 2009/0159674 A1* 6/2009 King G06Q 20/18
 2009/0192950 A1 7/2009 King et al.
 2009/0267732 A1 10/2009 Chauvin et al.
 2009/0284907 A1 11/2009 Regimbal et al.
 2009/0315720 A1 12/2009 Clement et al.
 2010/0106517 A1 4/2010 Kociubinski et al.
 2010/0188932 A1 7/2010 Hanks et al.
 2010/0332394 A1 12/2010 Ioli
 2011/0063133 A1 3/2011 Keller et al.
 2011/0313822 A1 12/2011 Burdick et al.
 2011/0320243 A1 12/2011 Khan et al.
 2012/0084210 A1 4/2012 Farahmand
 2012/0158466 A1 6/2012 John
 2012/0222935 A1* 9/2012 MacKay G07F 17/248
 2012/0285790 A1 11/2012 Jones et al.
 2012/0285792 A1 11/2012 Jones et al.
 2012/0286036 A1 11/2012 Jones et al.
 2013/0005445 A1 1/2013 Walker et al.
 2013/0099943 A1 4/2013 Subramanya
 2013/0116952 A1 5/2013 Chai
 2014/0040028 A1 2/2014 King et al.

2014/0108107 A1 4/2014 Jones et al.
 2014/0129158 A1 5/2014 Shea
 2014/0174881 A1 6/2014 King et al.
 2014/0210646 A1 7/2014 Subramanya
 2014/0214499 A1 7/2014 Hudson et al.
 2014/0214500 A1 7/2014 Hudson et al.
 2014/0229246 A1 8/2014 Ghaffari
 2014/0289025 A1 9/2014 King et al.
 2015/0084786 A1 3/2015 King et al.
 2015/0106172 A1 4/2015 Salama
 2015/0129391 A1* 5/2015 Jones G07B 15/02
 194/350
 2017/0098339 A1 4/2017 Keller et al.
 2018/0025549 A1 1/2018 King et al.
 2018/0225909 A1* 8/2018 MacKay G07F 17/248
 2019/0131819 A1* 5/2019 Bell G07F 17/248

FOREIGN PATENT DOCUMENTS

EP 0329129 A2 8/1989
 EP 0980055 B1 9/2001
 EP 1128350 B1 10/2007
 FR 2837583 A1 9/2003
 IL 149880 A 6/2007
 JP S5259000 A 5/1977
 JP S58121494 A 7/1983
 JP 2002042181 A 2/2002
 JP 2002099640 A 4/2002
 JP 2005267430 A 9/2005
 KR 20050038077 A 4/2005
 WO WO-2005031494 A2 4/2005
 WO WO-2006095352 A2 9/2006
 WO WO-2009154787 A2 12/2009
 WO WO-2014014494 A1 1/2014

OTHER PUBLICATIONS

City of Culver City. CA Agenda Item Report. Approval of a Contract with IPS Group Inc., for the Sole-Source Purchase of 1,000 Parking Meters. (3 pgs.) (Dec. 12, 2011).
 Decision Denying Institution of Inter Partes Review dated Mar. 30, 2016 of U.S. Pat. No. 7,854,310. IPR Case No. IPR2016-00068.
 Decision Denying Inter Partes Review dated Apr. 1, 2016 of U.S. Pat. No. 8,595,054. IPR Case No. IPR2016-00069.
 Decision Denying Inter Partes Review dated Apr. 1, 2016 of U.S. Pat. No. 8,595,054. IPR Case No. IPR2016-00070.
 Decision Instituting Inter Partes Review dated Mar. 30, 2016 of U.S. Pat. No. 7,854,310. IPR Case No. IPR2016-00067.
 Fidelman. Time's Running Out for Parking Meters at Present Locations: \$270,000 Cited as Replacement Cost. City Employees Who Ticket Motorists Find Electronic Meters Unsuitable. The Gazette, Final Edition, Montreal, Quebec, Canada, Nov. 12, 2002, p. A7.
 Final Written Decision of U.S. Pat. No. 7,854,310. IPR Case No. IPR2016-00067 dated Mar. 27, 2017.
 Flatley. In San Francisco, Hackers Park for Free. Read filed under Misc. Gadgets, downloaded from www.engadget.com website on May 3, 2010. Originally posted on Jul. 31, 2009 (5 pgs.).
 Howland. How M2M Maximizes Denver's Revenue. Field TechnologiesOnline.com, Oct. 2011, pp. 9-12 [online] [retrieved Mar. 5, 2013], Retrieved from http://www.fieldtechnologiesonline.com/doc.mvc/How-M2M-Maximizes-Denvers-Revenue-0001 (4 pgs.).
 Jim Bonfield. An Exercise in Changing the Business: Advertising Vending Machines. (4 pgs.) (Feb. 7, 2018).
 Meter Solutions, Single-Space Meters brochure, downloaded from www.duncansolutions.com website. (revised Apr. 2006) (2 pgs.).
 PCT/IB2006/054574 International Preliminary Report on Patentability dated Mar. 10, 2009.
 PCT/IB2006/054574 International Search Report dated Oct. 27, 2008.
 PCT/US2010/047906 International Preliminary Report on Patentability dated Mar. 6, 2012.
 PCT/US2010/047906 International Search Report dated Mar. 30, 2011.

(56)

References Cited

OTHER PUBLICATIONS

PCT/US2010/047907 International Preliminary Report on Patentability dated Mar. 15, 2012.

PCT/US2010/047907 International Search Report dated Apr. 26, 2011.

PCT/US2012/048190 International Search Report dated Jan. 22, 2013.

Petition for Inter Partes Review of U.S. Pat. No. 7,854,310. IPR Case No. IPR2016-00067, filed Oct. 22, 2015.

Petition for Inter Partes Review of U.S. Pat. No. 7,854,310. IPR Case No. IPR2016-00068, filed Oct. 22, 2015.

Petition for Inter Partes Review of U.S. Pat. No. 8,595,054. IPR Case No. IPR2016-00069, filed Oct. 22, 2015.

Petition for Inter Partes Review of U.S. Pat. No. 8,595,054. IPR Case No. IPR2016-00070, filed Oct. 22, 2015.

Sedadi. Card & Coin Parking Meter Lease. City of Los Angeles Inter-Departmental Correspondence. (4 pgs.) (Nov. 29, 2010).

Spyker et al. Predicting Capacitor Run Time For a Battery/Capacitor Hybrid Source. Power Electronic Drives and Energy Systems for Industrial Growth. 1998. Proceedings. 1998 IEEE International Conference, pp. 809-814.

The U.S. Conference of Mayors Presents 'Best Practice' Awards, Los Angeles, New Orleans, Elizabeth, N.J. and Long Beach, CA Honored for Excellence & Innovation in Public-Private partnerships, Press Release Jan. 20, 2012 (3 pgs.).

Transportation Commission Staff Report. Alternate Downtown Parking Pay Technology. Agenda Item No. 5.b (4 pgs.) (Oct. 20, 2011).

Tung. Design of an advanced on-street parking meter. RIT Scholar Works. Thesis/Dissertation Collections (75 pgs.) (2001).

* cited by examiner

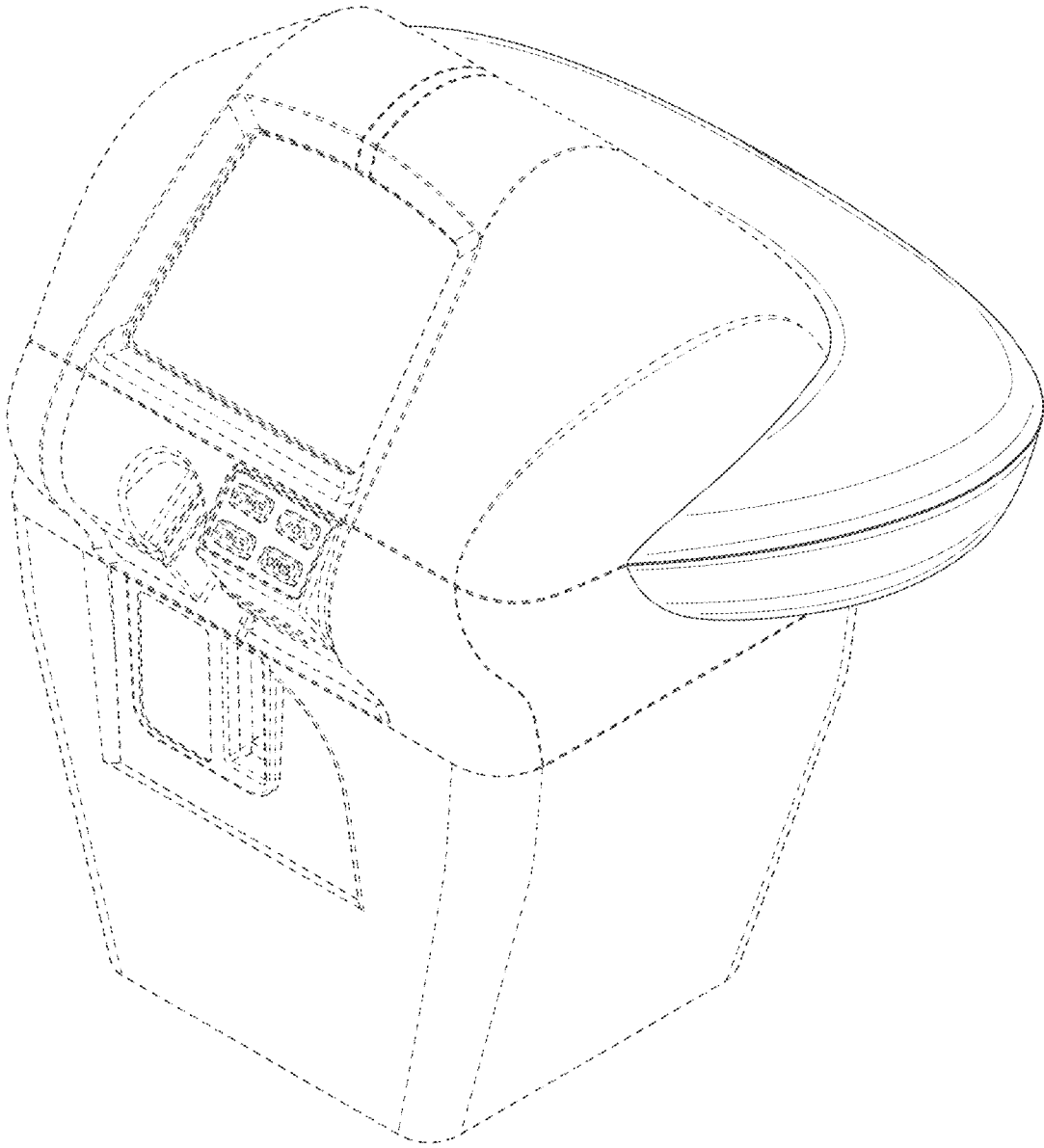

FIG. 1

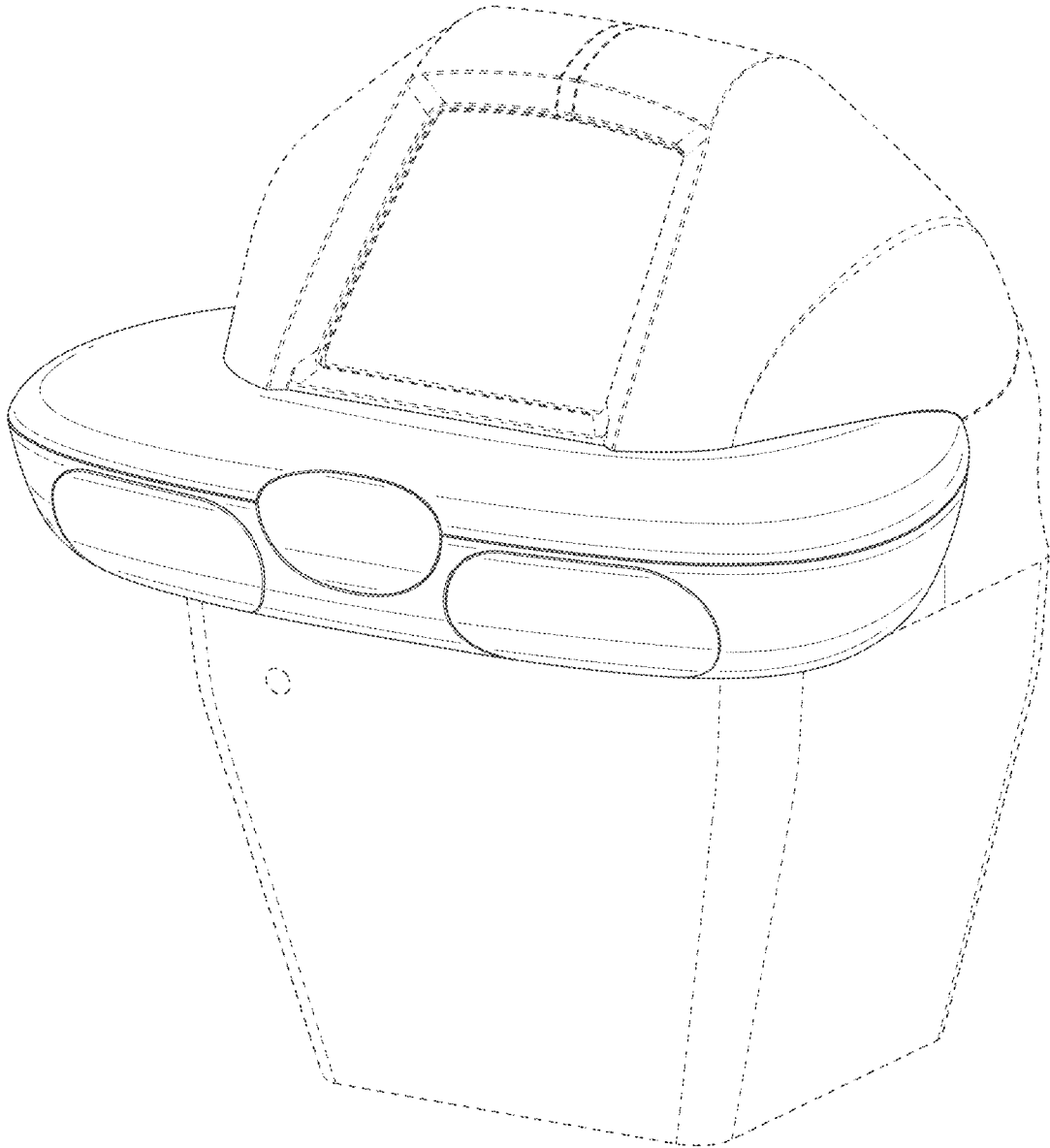

FIG. 2

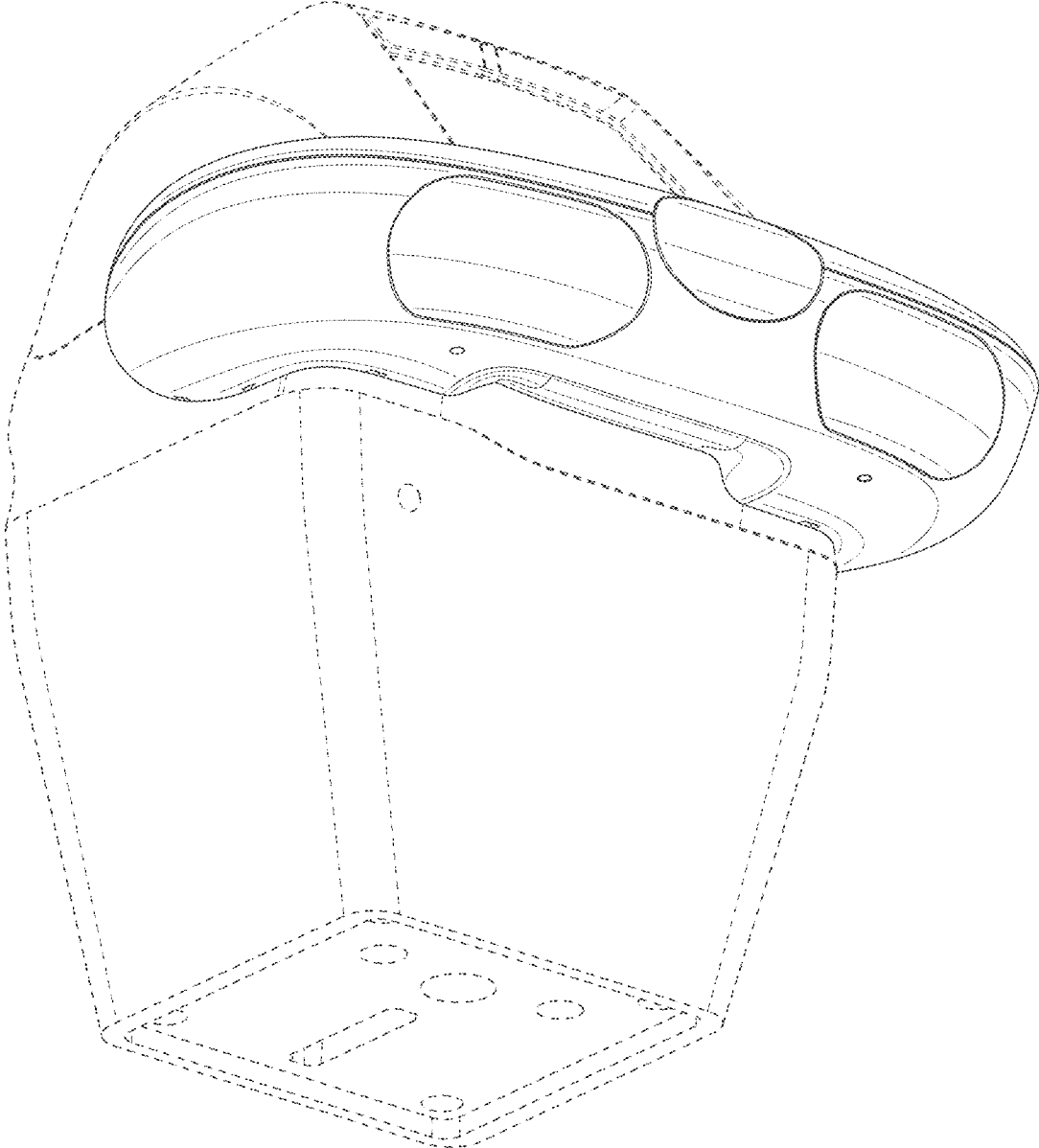

FIG. 3

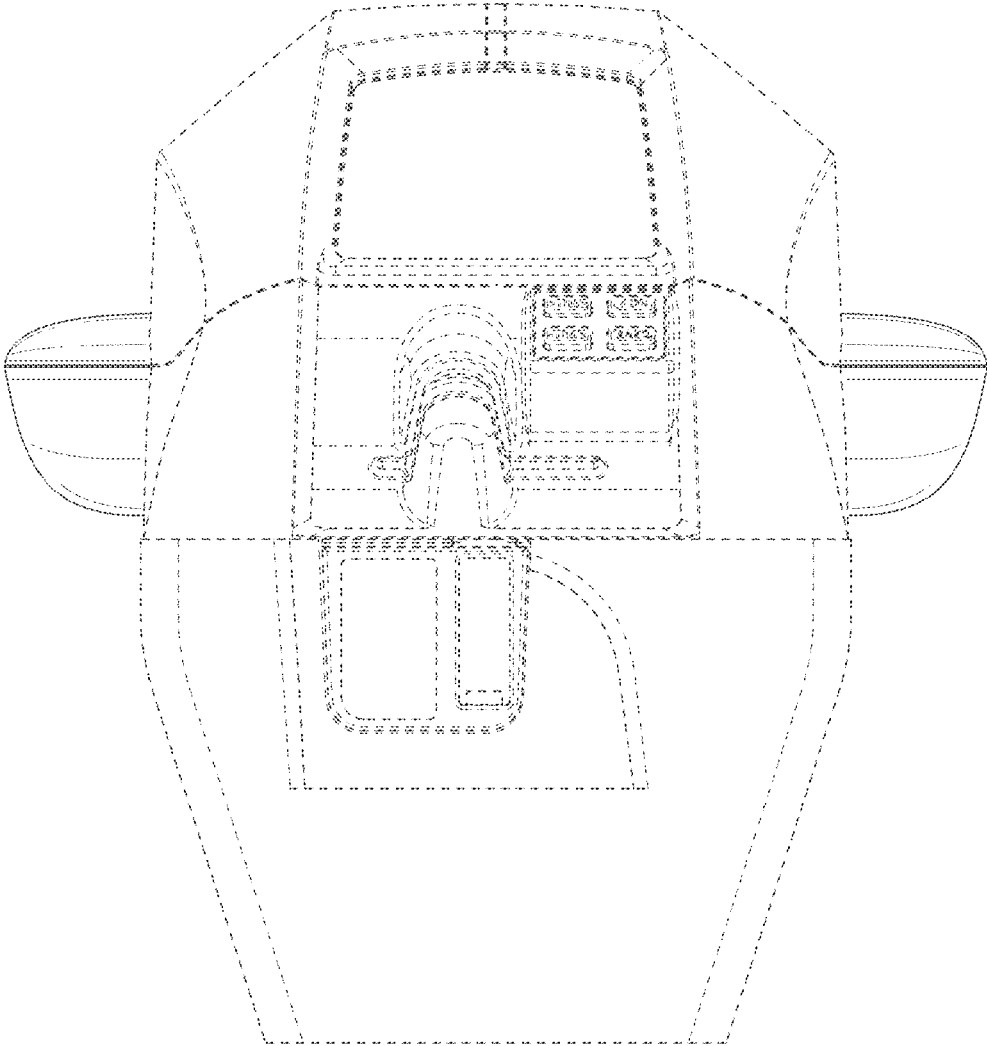

FIG. 4

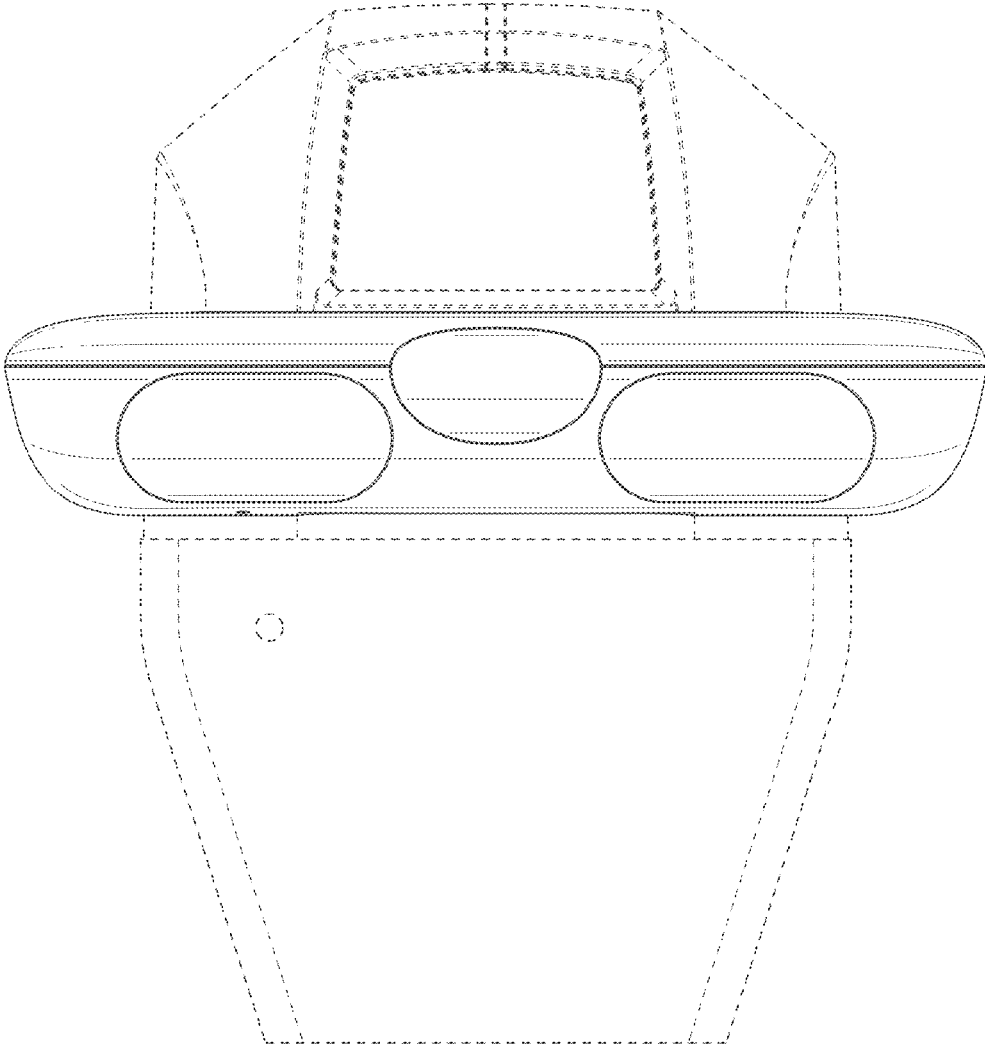

FIG. 5

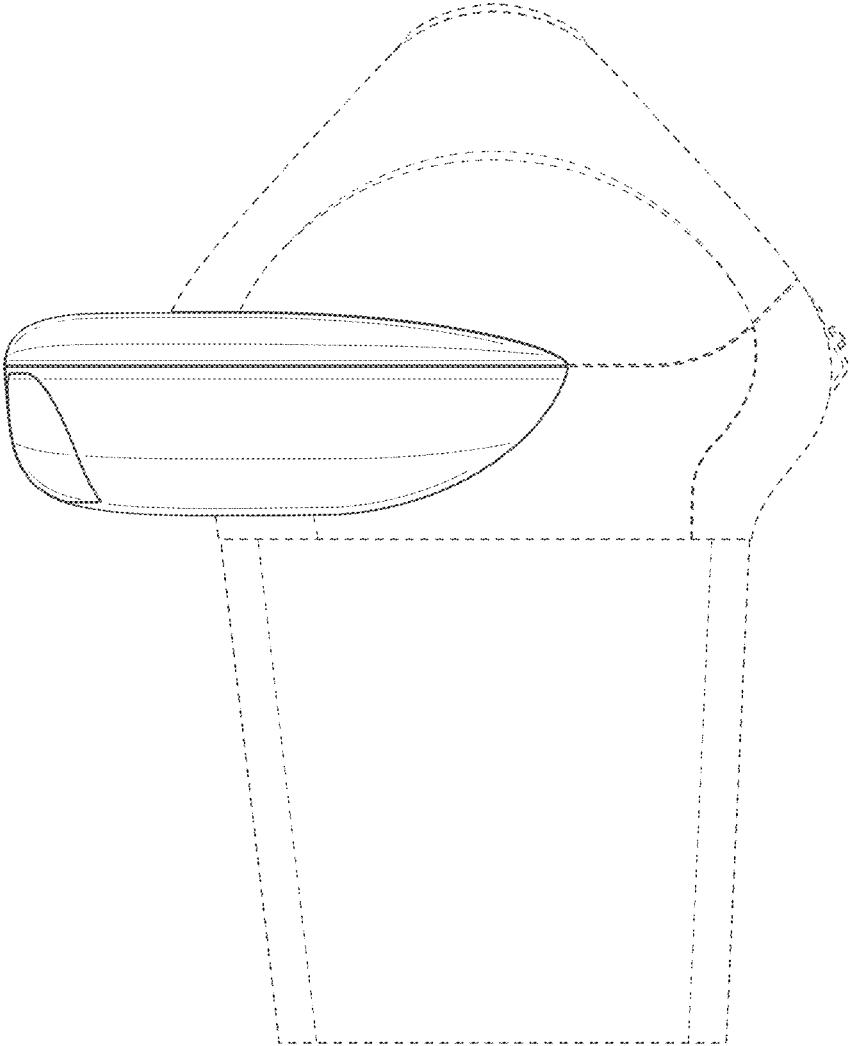

FIG. 6

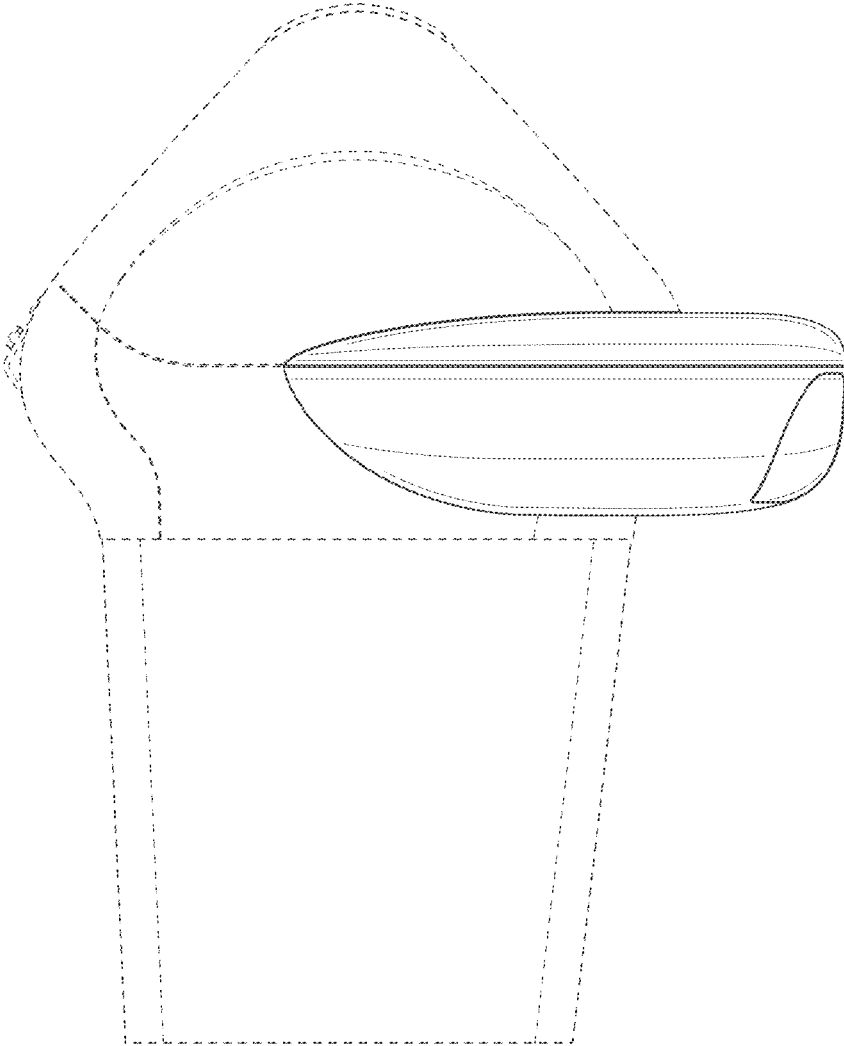

FIG. 7

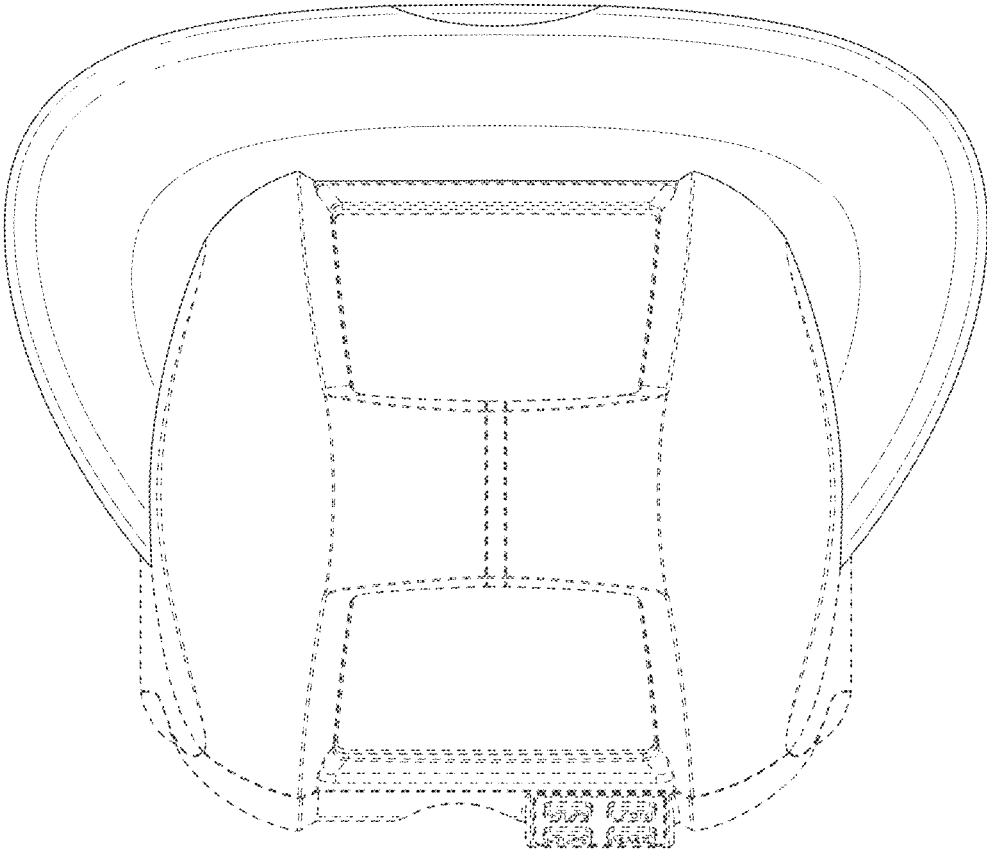

FIG. 8