



US 20050108953A1

(19) **United States**

(12) **Patent Application Publication**
Berdan et al.

(10) **Pub. No.: US 2005/0108953 A1**

(43) **Pub. Date: May 26, 2005**

(54) **ENCLOSURE**

(22) Filed: **Nov. 24, 2003**

(75) Inventors: **Brian J. Berdan**, Montgomery, MN (US); **Lisa A. Berdan**, Montgomery, MN (US)

Publication Classification

(51) **Int. Cl.⁷ E04H 1/00**

(52) **U.S. Cl. 52/79.1**

Correspondence Address:

BAKER & HOSTETLER LLP
Washington Square, Suite 1100
1050 Connecticut Avenue, N.W.
Washington, DC 20036 (US)

(57) **ABSTRACT**

An enclosure for use during inspection of a vehicle is provided. The enclosure is attached to the vehicle by a securing member and helps to control the environment, such as reducing the light or decreasing any air movement during inspection. The enclosure provides a control environment during the inspection of the vehicle to ensure accurate testing.

(73) Assignee: **SPX Corporation**

(21) Appl. No.: **10/718,579**

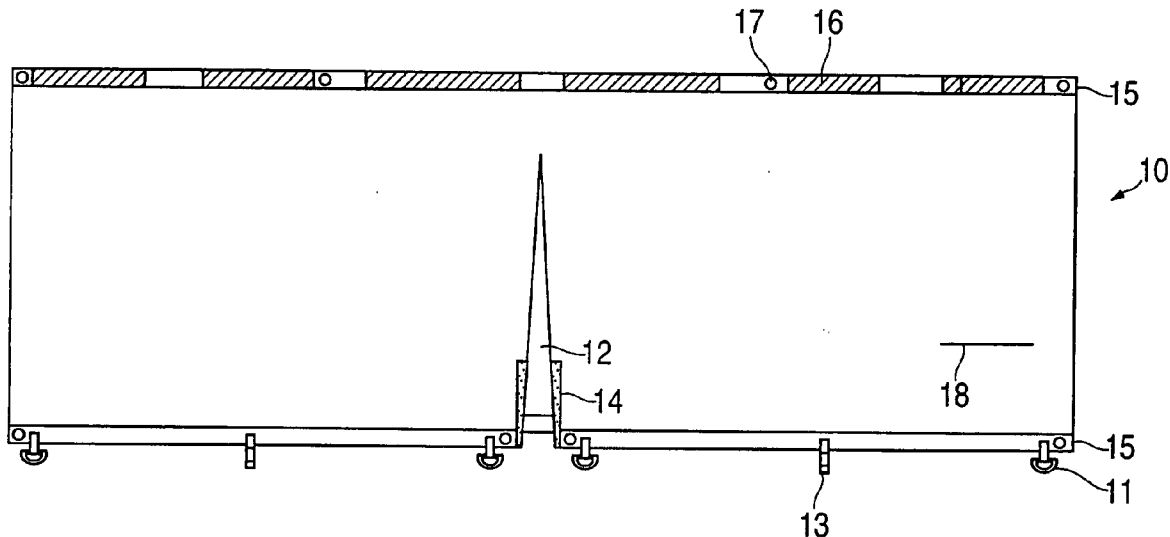

FIG. 1

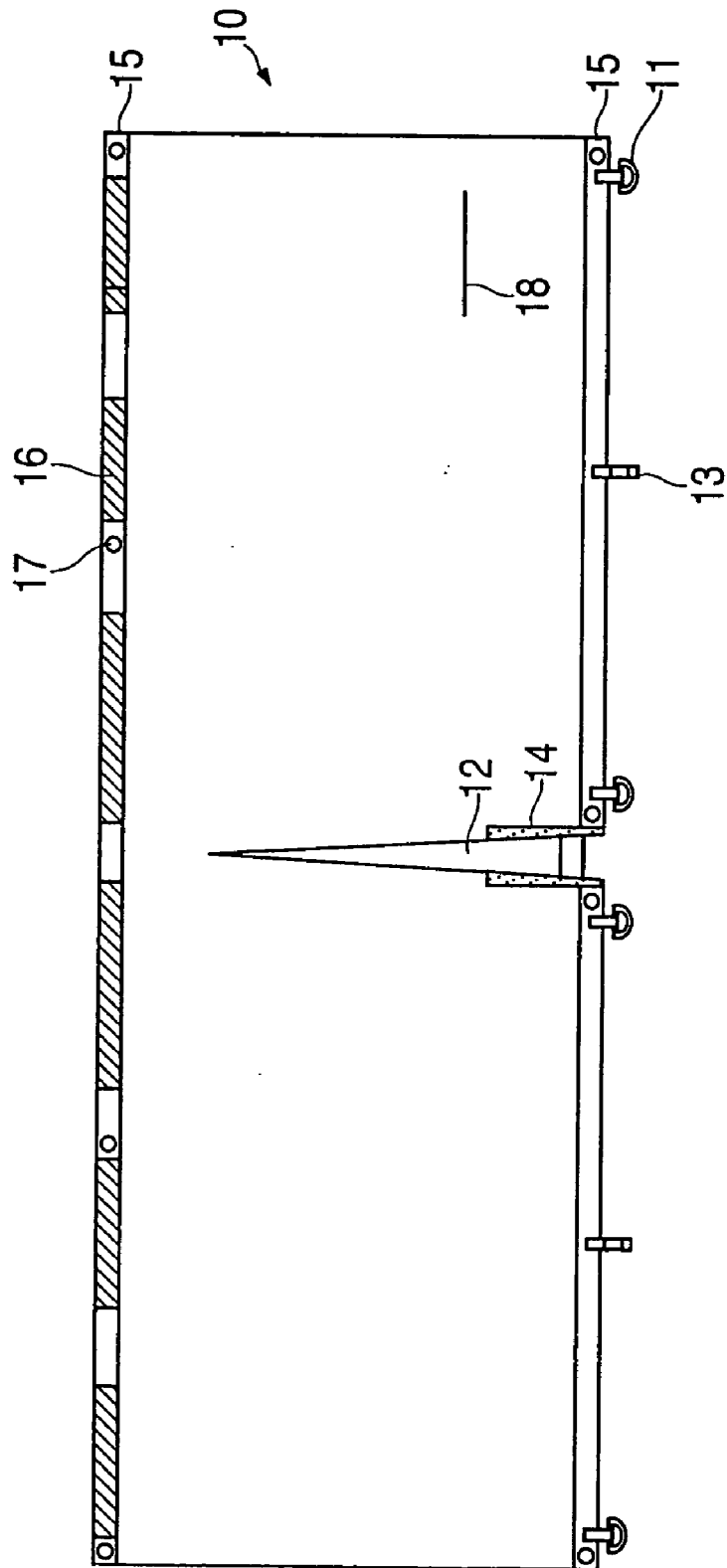

FIG. 2A

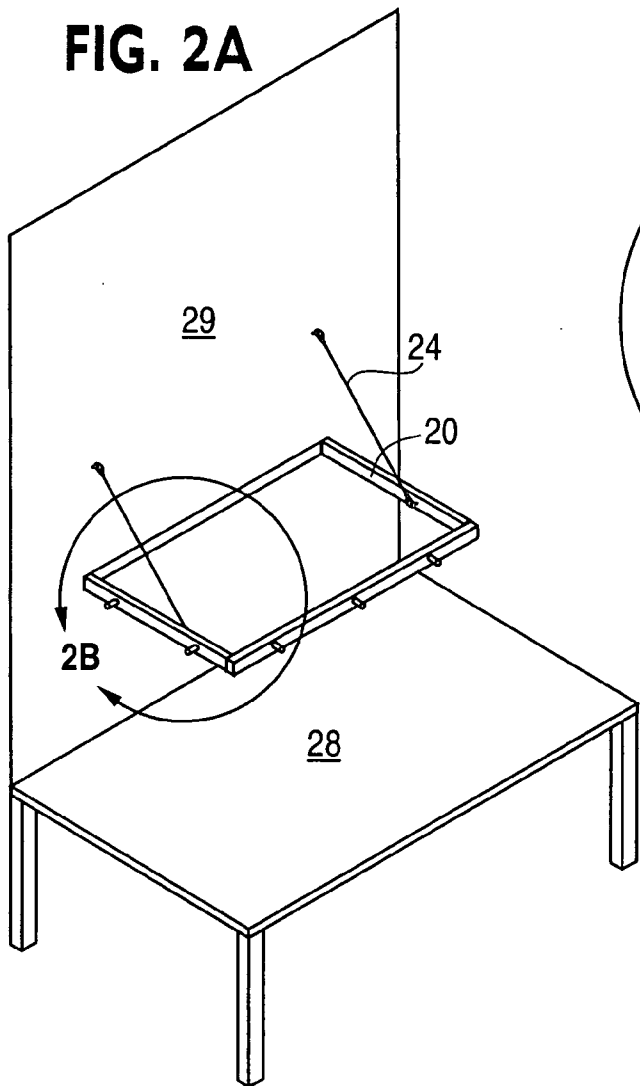

FIG. 2B

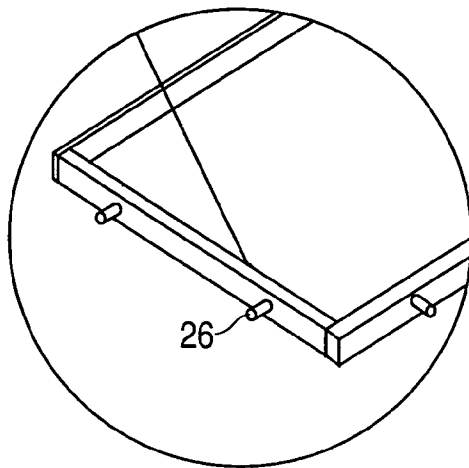

FIG. 2C

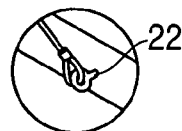

FIG. 3

30

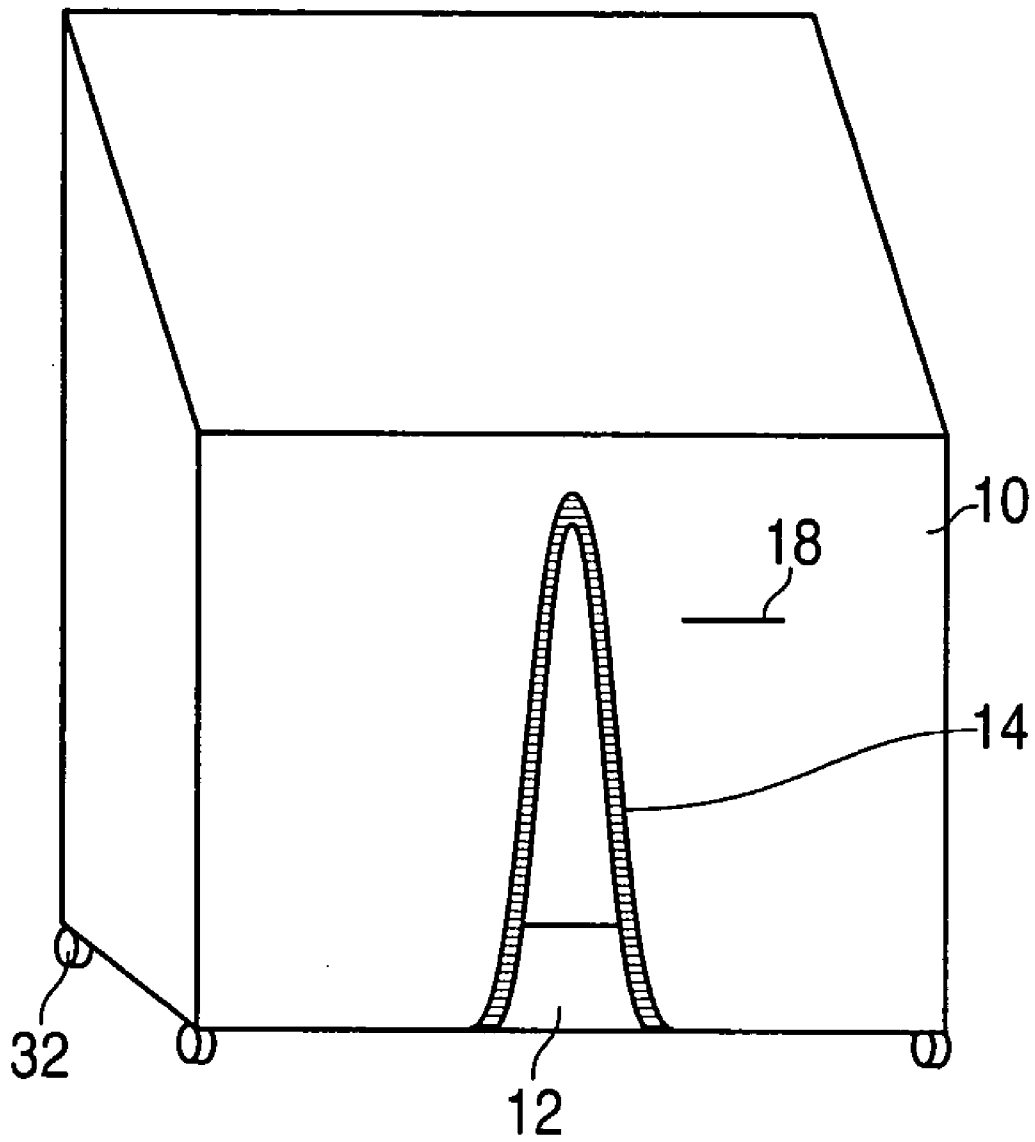
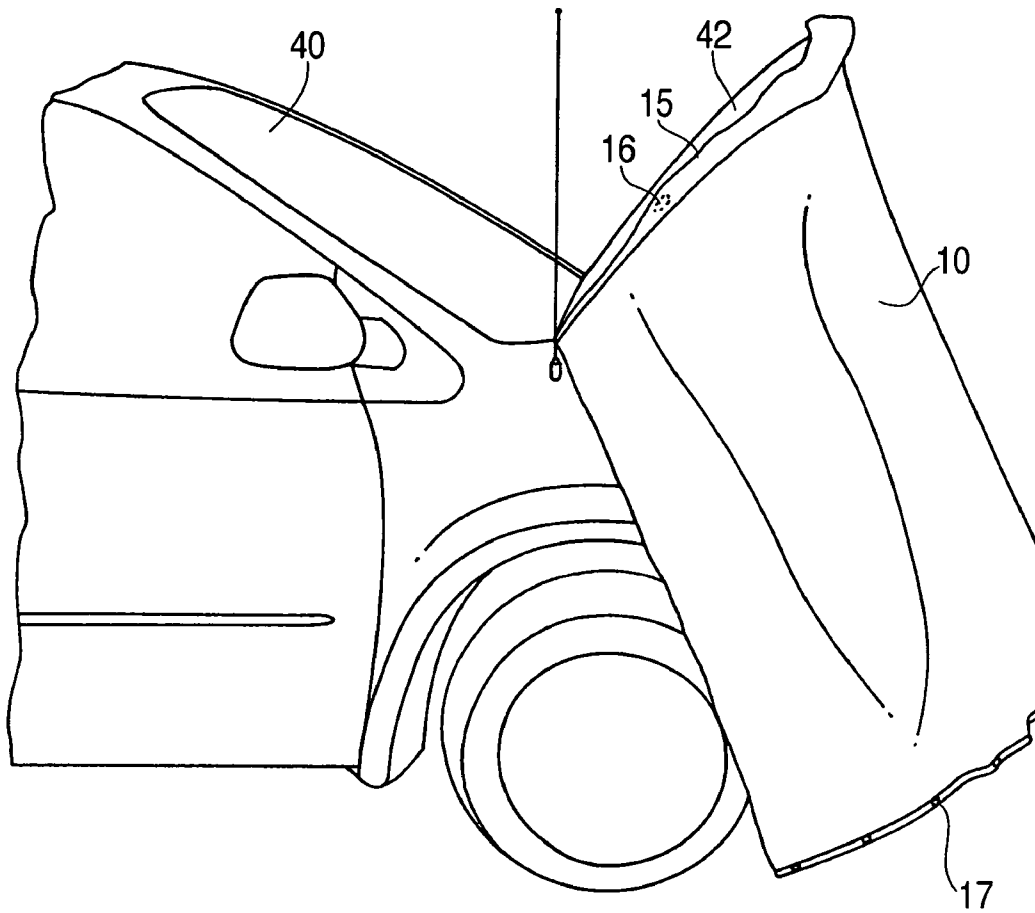

FIG. 4



ENCLOSURE

FIELD OF THE INVENTION

[0001] The present invention relates generally to an enclosure. More particularly, the present invention relates to an enclosure used during inspection of a vehicle.

BACKGROUND OF THE INVENTION

[0002] Inspection and maintenance of a vehicle are often done outside or in an illuminated facility, such as a garage. The inspection can include detecting leaks in air conditioning or refrigeration systems, brake systems, transmissions, cylinder head, radiators or other devices containing fluids.

[0003] For example, to test for a leak in the air conditioning system of the vehicle, a fluorescent dye is added to a refrigerant, which is then added to the air conditioning system under pressure. The air conditioning system is turned on for a sufficient amount of time for the refrigerant along with the fluorescent dye to circulate through out the system. If there is a leak in the system, the fluorescent dye is detected with a black light. However, if the inspection is done in an outside environment with the black light, it may be difficult to detect small leaks due to the ambient light. Thus, more expensive, high-intensity black lights must be purchased in order to detect the smaller leaks. Additionally, if the inspection is done inside, such as the garage, the lights must be turned off or the garage door is closed in order to maximize the black light's ability to "light up" the dye. With the lights in the garage turned off, other mechanics may not be able to continue their work for safety reasons, thereby increase the time of repair and costs to their customers.

[0004] Another way to detect refrigerant leaks is through electronic leak detectors. The electronic leak detectors can be used to initially detect a refrigerant leak or verify if the repairs of the air conditioning system was successful. The electronic leak detectors work by detecting the concentration of the refrigerant leaking out from the air conditioning system. However, the reliability of the electronic leak detectors is greatly reduced in an open-air environment where the prevailing winds can dilute the concentration of the refrigerant leak, thus decreasing the ability of the leak detectors to detect small leaks. This can also happen in the garage when the garage doors are open and drafts of air can flow through the garage and dilute the concentration of the refrigerant leak, thus decreasing the ability of the leak detectors to detect small leaks. If the leaks are not properly repaired, valuable refrigerant will be lost to the atmosphere.

[0005] Accordingly, it is desirable to provide a method and apparatus that allow for inspection of the vehicle without the need to turn off the light in the garage. Additionally, it is desirable to provide a method and apparatus to allow for inspection of the vehicle inside or outside regardless of the prevailing wind or air movement that may be present.

SUMMARY OF THE INVENTION

[0006] The foregoing needs are met, to a great extent, by the present invention, wherein in one aspect a portable enclosure system is provided and includes a non-transparent material with at least one flap at an end, a slit in the non-transparent material for a user to traverse therethrough, a closing member to close the slit, and a securing member

coupled to at least a portion of the non-transparent material and can attach the enclosure to a section of a vehicle being inspected so that the enclosure surrounds the area of inspection and can prevent light from entering the section being inspected. The securing member can be at least one magnetic strip that is enclosed by the flap to prevent scratching the vehicle. Additionally, the vehicle can be inspected by using fluorescent techniques or by a leak detector. The portable enclosure can further include a pouch that can be attached to a portion of the non-transparent material. The material can be fabrics, natural or synthetic fibers, acrylic, synthetic rubberized lattices, vinyl, vinylidene polymers, copolymers, polymers, urethanes, ethylene interpolymer, PVC, polyethylenes, polypropylenes, geotextiles, other similar materials or a combination thereof. Further, the closing member can be Velcro®, fasteners, zipper, buttons, buckles, hooks, rivets, snaps, rings, locks, other closing members, and a combination thereof. The securing member can be magnetic strips, hooks, clips, grommets, ropes, snaps, fasteners, buttons, buckles, rivets, rings, locks, Velcro®, other securing means and a combination thereof.

[0007] In accordance with another embodiment, a method for inspecting an equipment is provided and can include preparing a vehicle for inspection using an inspecting technique, providing an enclosure around the vehicle to be inspected, preventing light from entering an area of the vehicle being inspected with the enclosure, securing the enclosure to at least a portion of the vehicle with a securing member, entering the enclosure through a slit in the enclosure, closing the slit with a closing member, and inspecting the area of the vehicle with an inspection tool. The enclosure can include a non-transparent material that minimizes the surrounding light. Inspecting the area of the vehicle can be done with a leak detector or a black light. The inspection method can further include slowing the movement of air into the area being inspected in a vehicle with the enclosure.

[0008] In accordance with another embodiment of the invention, a system for inspection is provided and can include means for enclosing around a portion of a vehicle to be inspected having at least a flap at an end, means for traversing through the means for enclosing, means for closing the traversing means, and means for securing the enclosing means to the vehicle so that the enclosure means prevents light from entering the portion of the vehicle being inspected. The means for securing can be at least one magnetic strip that is enclosed by the at least a flap. The inspection system can further include comprising a means to detect a defect in the vehicle. The means to detect may be a black light or a leak detector. Additionally, the enclosing means can include a material that can be fabrics, natural or synthetic fibers, acrylic, synthetic rubberized lattices, vinyl, vinylidene polymers, copolymers, polymers, urethanes, ethylene interpolymer, PVC, polyethylenes, polypropylenes, geotextiles, other similar materials or a combination thereof. The closing means can be Velcro®, fasteners, zipper, buttons, buckles, hooks, rivets, snaps, rings, locks, other closing members, and a combination thereof. The securing member can be magnetic strips, hooks, clips, grommets, ropes, snaps, fasteners, buttons, buckles, rivets, rings, locks, Velcro®, other securing means and a combination thereof. The inspection system can further include a means for storing located on a portion of the enclosure means. The means for securing can be encapsulated within a portion of the enclosing means to prevent damaging of the vehicle.

[0009] In accordance with yet another embodiment of the invention, an enclosure used in inspecting a vehicle can include an environmental controlling material with at a flap at a first end and a second end, a slit in the environmental controlling material for a user to traverse therethrough, a closing member to close the slit and prevent light from entering through the slit, and a securing member coupled to at least a portion of the non-transparent material and attaches the enclosure to a section of a vehicle being inspected so that the enclosure prevents light from entering the section being inspected.

[0010] There has thus been outlined, rather broadly, certain embodiments of the invention in order that the detailed description thereof herein may be better understood, and in order that the present contribution to the art may be better appreciated. There are, of course, additional embodiments of the invention that will be described below and which will form the subject matter of the claims appended hereto.

[0011] In this respect, before explaining at least one embodiment of the invention in detail, it is to be understood that the invention is not limited in its application to the details of construction and to the arrangements of the components set forth in the following description or illustrated in the drawings. The invention is capable of embodiments in addition to those described and of being practiced and carried out in various ways. Also, it is to be understood that the phraseology and terminology employed herein, as well as the abstract, are for the purpose of description and should not be regarded as limiting.

[0012] As such, those skilled in the art will appreciate that the conception upon which this disclosure is based may readily be utilized as a basis for the designing of other structures, methods and systems for carrying out the several purposes of the present invention. It is important, therefore, that the claims be regarded as including such equivalent constructions insofar as they do not depart from the spirit and scope of the present invention.

BRIEF DESCRIPTION OF THE DRAWINGS

[0013] FIG. 1 illustrates an enclosure in the extended position.

[0014] FIG. 2 illustrates a frame for use with the enclosure.

[0015] FIG. 3 illustrates a mobile enclosure that includes the enclosure covering the frame.

[0016] FIG. 4 illustrates the mobile enclosure affixed to a vehicle.

DETAILED DESCRIPTION

[0017] The invention will now be described with reference to the drawing figures, in which like reference numerals refer to like parts throughout. An embodiment in accordance with the present invention provides for a portable enclosure. The portable enclosure can be used to control the surrounding environmental conditions, such as air, temperature and lighting. Depending on the level of control desired by a user, the portable enclosure can be manufactured to maximize the amount of control.

[0018] FIG. 1 illustrates the enclosure 10 in the extended position. The enclosure 10 may be made from any material,

such as a tear resistant material, a fire resistant material, a snag resistant material, a stain resistant material, a UV resistant material, other types of resistant materials or a combination thereof. The material chosen should also be able to block out the undesirable light, such as the surrounding light so that inspection of the equipment on the vehicle can be conducted. Said material can be made of fabrics, natural or synthetic fibers, rubberized, treated or untreated fibers, waterproofed by impregnating various water proofing agents such as silicones, as well as variety of natural or synthetic coatings. More specifically, materials can be made from acrylic, synthetic rubberized latices, vinyl, vinylidene polymers, copolymers, polymer, urethanes, ethylene interpolymer, alloys, PVC, polyethylenes, polypropylenes, geotextiles, other similar materials or a combination thereof.

[0019] The enclosure 10 includes a slit 12 or opening that can be held together by a closing member 14, a pouch 18, and a flap 15 that can have various securing members to secure the enclosure 10 to a desired object, such as the vehicle. The slit 12 allows the user to enter, exit or have access to the inside or outside of the enclosure 10. The slit 12 can be located in the middle of the enclosure and constructed and arranged in the proper dimensions so that the user can enter or exit. The slit 12 can also be located in other places along the enclosure 10 for easy access and exit.

[0020] The closing member 14 is constructed and arranged to close the slit 12 so that the inspection can be conducted with minimum lighting or air movement entering through the slit. The closing member 14 can be Velcro®, fasteners, zipper, buttons, buckles, hooks, rivets, snaps, rings, locks, other closing members that can act to close the slit, or a combination thereof.

[0021] The pouch 18 provides a place to hold articles, such as tools, equipment, dyes, manuals, or any other articles that the user may need to perform the inspection. The pouch 18 can be located on the outside or the inside of the enclosure 10. The pouch 18 can be open or can be closed by having the closing member 14 thereon. Additionally, the pouch 18 can be constructed and arranged to be any dimensions suitable to the user's needs.

[0022] The flap 15 can be located at a top portion, bottom portion, side portion or along any of the enclosure's edge. The flap 15 can be used to help secure the enclosure 10 to the vehicle or any other object. The flap 15 can include magnetic strips 16 attached to the flap in a way that they will not scratch the vehicle. Because the strips are magnetic, they can secure the enclosure 10 to the vehicle. Additionally, the magnetic strips 16 can be encapsulated therein to further protect against scratching the surface of the vehicle or object. Additionally, the strips can be one continuous piece or separate pieces spaced throughout the flap 15. As stated above, the magnetic strips 16 can be located on any portion of the flap 15, including the bottom portion. By having magnetic strips 16 located at the bottom portion (in addition to the top portion), the enclosure 10 can be further secured to the vehicle and/or the enclosure can be weighted down to stretch out the material. Although, magnetic strips 16 can be used to weigh the enclosure downward, other suitable materials that can weigh downward the enclosure can also be used alone or in combination with the strips.

[0023] In another embodiment, hooks 11 secure the enclosure 10 to the vehicle. The hooks 11 is attached to the flap

15 to hook onto a protruding member located on the vehicle or object such as a frame discussed below. The hooks can be any shape and size so long as it able to secure the enclosure to the vehicle or object. Clips **13** can also be used to secure the enclosure to the vehicle or object. As shown in **FIG. 1**, the clips are attached to the flap **15** and can be used to secure the enclosure to any part of the vehicle or object.

[0024] Grommets **17** can also be provided on the flap **15** to help secure the enclosure **10** to the vehicle or object. The grommets can be made from polyethylene terephthalate (PET), high-density polyethylene (HDPE), polyvinyl chloride (PVC), low density polyethylene (LDPE), polypropylene (PP), other plastic, polymers, monomer, or other suitable materials so long as they do not scratch the surface of the object that the enclosure is attached to. The grommets can also be made from brass, steel, metal, alloy, aluminum, copper, and nickel so long as they are covered with a scratch resistant material. Ropes or a similar material can be threaded through an eye of the grommet, allowing the enclosure to be secured or tied to the vehicle or object.

[0025] Other ways to secure the enclosure to the vehicle can include snaps, fasteners, buttons, buckles, rivets, rings, locks, Velcro®, and other securing means. It should be noted by a person skilled in the art that the aforementioned securing members can be used alone or in combination with each other.

[0026] The enclosure can be used to inspect a vehicle that may have a fluid leak, such as a refrigerant leak. Fluorescent dyed refrigerant can be added the refrigerant system of the vehicle and cycled through the system. The enclosure **10** can be secured to the vehicle by the magnets in the flap or other securing means previously described. The enclosure **10** should be secured enough to cover the portion of the vehicle being inspected for a leak so that the surrounding light or air movement does not penetrate the inside of the enclosure. The user enters the enclosure through the slit **12** and can close the slit with the closing member **14**, such as Velcro®. The pouch **18** located on the outside or the inside of the enclosure stores articles that may be needed by the user during the inspection.

[0027] By using the enclosure during inspection of a vehicle, surrounding light entering the area of inspection is reduced so that small leaks can be better detected by the black light. Additionally, with the decrease in ambient light, standard black light can be used instead of the more expensive, high-intensity black lights, thus saving money for the user. Further, reducing air movement to the area being inspected reduces false readings by the refrigerant leak detector because there is less chance of diluting the leaking gas.

[0028] In another embodiment, the enclosure **10** is secured to a frame **20**. **FIG. 2** illustrates the frame **20** for use with the enclosure **10**. The frame **20** can be any size or dimension and made from any material required by the user. For example, the frame can be rectangular in shape with the dimensions being between about 3 feet to 20 feet in length, 1 foot to 10 feet in width and about 1" to 1 foot in height. Further the frame can be made from a ferromagnetic material, steel, polymer, brass, metal, alloy, aluminum, copper, nickel, other materials that provides a sturdy frame or a combination thereof. The frame includes eye hooks **22** that hook with wire **24**, which is attached to a wall **29**. The wall

29 can be a wall in the garage or any other suitable wall. The frame also includes protrusion members **26** that is constructed and arranged to receive the securing member such as the eyelet.

[0029] A table **28**, a work bench or similar structure can be provided so that the equipment to be inspected can be placed thereon. The frame **20** can be smaller, larger or the same size as the table **28** and vice versa. The enclosure **10** can be attached to the frame **20** and together with the table **28** can dramatically decrease the amount of light or reduce the amount of moving air penetrating the enclosure so that the inspection can proceed in a more controlled environment.

[0030] In operation, the equipment to be tested is set on the table. The fluorescent dye can be cycled through the equipment for leak inspection if the black light is used. The enclosure attached to the frame can be drawn closed around the equipment to keep the ambient light out and decrease air movement. The black light is used to detect the leak by illuminating the dye. In conjunction with the black light or in the place of the black light, the leak detector can be used to detect a leak. After the leak is detected, the repairs are completed on the table or in another portion of the garage. Once the repairs are completed, the equipment can be tested again by closing the enclosure being held by the frame. Again, the black light and/or the leak detector is used to ensure that the repairs were done correctly.

[0031] In an alternative embodiment, the enclosure **10** can be attached to the frame **20** without the table **28**. The equipment to be inspected may be too big to put on the table, such as the vehicle's engine, and thus the table is not needed. The enclosure along with the frame can decrease the amount of ambient light or reduce the amount of moving air so that the inspection can proceed.

[0032] In still another embodiment, the enclosure along with the frame is mobile. **FIG. 3** illustrates a mobile enclosure **30** that includes the enclosure **10** covering the frame **20**. The enclosure **10** can be secured to the frame **20** with the securing members discussed above. The slit **12** allows the user to enter or exit the mobile enclosure **30**. The closing member **14**, such as Velcro® can be used to close the slit **12** as to further control the environment for inspection. The pouch **18** can be located inside or outside of the mobile enclosure **30**. The mobile enclosure **30** is moved by wheels or other suitable mobile means that are attached to the bottom of the frame. In use, the mobile enclosure **30** can be moved to the desired location to inspect equipment. This may be useful when the equipment to be inspected is too heavy to move or if there is no object to which the enclosure can attach to in order to inspect the equipment.

[0033] By having an enclosure attached to a frame, the user can inspect the equipment away from the vehicle. This way other portions of the vehicle can be worked by another user during the inspection. By simply moving the mobile enclosure to the equipment to be inspected, the user can save time and money that might have been spent on moving the equipment to a fixed enclosure.

[0034] In a further embodiment, because the enclosure is mobile, it can be attached to a portion of a vehicle for inspection. For example, the enclosure can be attached to a hood of a vehicle. **FIG. 4** illustrates the mobile enclosure **10** affixed to a vehicle **40**. It should be noted that the mobile

enclosure 10 can be attached to any portion of the vehicle. The mobile enclosure 10 attaches to the hood 42 of the vehicle 40 and encloses the area of the vehicle being inspected, such as the engine compartment. The flap 15 can have magnetic strips 16 therein to attach the enclosure 10 to the hood 42. Other securing means as previously described can also be used to secure the enclosure 10 to the vehicle including the use of the grommets 17. Additionally, flap 15 with the magnetic strips (and other securing means) can be positioned at the bottom of the enclosure to weigh the enclosure down and prevent movement of the enclosure. The slit (not shown) allows the user to enter the enclosure and perform the inspection. Because the enclosure is designed to enclose around the area of inspection the surrounding light is prevented from entering the enclosure so that the inspection can occur in the most optimum conditions. Additionally, air movement is also decreased in order to minimize false readings by the leak detector. Although the vehicle shown in FIG. 4 is a van, the portable enclosure can also be used on a boat, car, motorcycle, plane, train or other vehicles.

[0035] Although the inspection technique described herein relates to fluorescent dyed refrigerant, other techniques can also be used. One technique is penetrant inspection, wherein a fluorescent penetrant spray is used to spray an area believed to be cracked in the work piece and a developer is applied to reveal the cracks or defects in the work piece. A black light can be used to visually inspect where the defects may be in the work piece and thus, the portable enclosure can be used to block the surrounding light for better inspection. Water washable fluorescent penetrant, emulsifiable fluorescent penetrant can also be used. Another inspection technique is magnetic particle inspection, where it uses fluorescent magnetic particles along with a magnetic field to reveal defects in work piece that is made from a ferromagnetic material. Again, the enclosure and the black light can be used to visually inspect the fluorescent magnetic material.

[0036] Other uses of the enclosure 10 includes protection of harmful UV light while working outside, easier reading of the LED screen on a scan tool or easier setting of the timing light due to decrease in ambient light, wind screen, cover for a vehicle and other uses.

[0037] The many features and advantages of the invention are apparent from the detailed specification, and thus, it is intended by the appended claims to cover all such features and advantages of the invention which fall within the true spirit and scope of the invention. Further, since numerous modifications and variations will readily occur to those skilled in the art, it is not desired to limit the invention to the exact construction and operation illustrated and described, and accordingly, all suitable modifications and equivalents may be resorted to, falling within the scope of the invention.

What is claimed is:

1. A portable enclosure system, comprising:
 - a non-transparent material with at least one flap at an end;
 - a slit in the non-transparent material for a user to traverse therethrough;
 - a closing member to close the slit; and
 - a securing member coupled to at least a portion of the non-transparent material and attaches the enclosure to a section of a vehicle being inspected so that the

enclosure surrounds the area of inspection and prevents light from entering the section being inspected.

2. The enclosure of claim 1, wherein the securing member is at least one magnetic strip and is enclosed by the flap to prevent scratching the vehicle.

3. The enclosure of claim 1, wherein the vehicle is being inspected by using fluorescent techniques or by a leak detector.

4. The enclosure of claim 1 further comprising a pouch that is attached to a portion of the non-transparent material.

5. The enclosure of claim 1, wherein the material can be fabrics, natural or synthetic fibers, acrylic, synthetic rubberized lattices, vinyl, vinylidene polymers, copolymers, polymers, urethanes, ethylene interpolymer, PVC, polyethylenes, polypropylenes, geotextiles, other similar materials and a combination thereof.

6. The enclosure of claim 1, wherein the closing member is selected from a group consisting of Velcro®, fasteners, zipper, buttons, buckles, hooks, rivets, snaps, rings, locks, other closing members, and a combination thereof.

7. The enclosure of claim 1, wherein the securing member is selected from a group consisting of magnetic strips, hooks, clips, grommets, ropes, snaps, fasteners, buttons, buckles, rivets, rings, locks, Velcro®, other securing means and a combination thereof.

8. A method for inspecting equipment, comprising:

- preparing a vehicle for inspection using an inspecting technique;

- providing an enclosure around the vehicle to be inspected;

- preventing light from entering an area of the vehicle being inspected with the enclosure;

- securing the enclosure to at least a portion of the vehicle with a securing member;

- entering the enclosure through a slit in the enclosure;

- closing the slit with a closing member; and

- inspecting the area of the vehicle with an inspection tool.

9. The inspecting method of claim 8, wherein the enclosure includes a non-transparent material that minimizes the surrounding light.

10. The method of claim 8, wherein inspecting the area of the vehicle is with a leak detector or a black light.

11. The method of claim 8 further comprising slowing the movement of air into the area being inspected in a vehicle with the enclosure.

12. A system for inspection, comprising:

- means for enclosing around a portion of a vehicle to be inspected having at least a flap at an end;

- means for traversing through the means for enclosing;

- means for closing the traversing means; and

- means for securing the enclosing means to the vehicle so that the enclosure means prevents light from entering the portion of the vehicle being inspected.

13. The inspection system of claim 12, wherein the means for securing is at least one magnetic strip that is enclosed by the at least a flap.

14. The inspection system of claim 12 further comprising a means to detect a defect in the vehicle.

15. The inspection system of claim 14, wherein the means to detect is a black light or a leak detector.

16. The inspection system of claim 12, wherein the enclosing means includes a material that can be fabrics, natural or synthetic fibers, acrylic, synthetic rubberized lattices, vinyl, vinylidene polymers, copolymers, polymers, urethanes, ethylene interpolymer, PVC, polyethylenes, polypropylenes, geotextiles, other similar materials or a combination thereof.

17. The inspection system of claim 12, wherein the closing means is selected from a group consisting of Velcro®, fasteners, zipper, buttons, buckles, hooks, rivets, snaps, rings, locks, other closing members, and a combination thereof.

18. The inspection system of **12**, wherein the securing member is selected from a group consisting of magnetic strips, hooks, clips, grommets, ropes, snaps, fasteners, buttons, buckles, rivets, rings, locks, Velcro®, other securing means and a combination thereof.

19. The inspection system of claim 12 further comprising a means for storing located on a portion of the enclosure means.

20. The inspection system of claim 12, wherein the means for securing is encapsulated within a portion of the enclosing means to prevent damaging of the vehicle.

21. An enclosure used in inspecting a vehicle, comprising:

an environmental controlling material with at a flap at a first end and a second end;

a slit in the environmental controlling material for a user to traverse therethrough;

a closing member to close the slit and prevent light from entering through the slit; and

a securing member coupled to at least a portion of the non-transparent material and attaches the enclosure to a section of a vehicle being inspected so that the enclosure prevents light from entering the section being inspected.

* * * * *