

(19)
(12)

(KR)
(B1)

(51) 。 Int. Cl.7
D06F 33/02

(45)
(11)
(24)

2004 08 21
10-0444957
2004 08 09

(21) 10-2002-0008439
(22) 2002 02 18

(65)
(43)

10-2003-0068808
2003 08 25

(73) 416

(72) 152 1303

2 219 803

302 603

1 2 1804

901 2004

3 1506-42 203

(74)
:

(54)

가 .

가 ,

8a

1
2 , 2a 가
3 , 2b 가
4
5 4 V-V
6
7 6 VII-VII
8 , 8a , 8b
, 8c 8d , 8e

* *
20 : 21 :
22 : 30 :
60 :

bling) , (wob
가 가
가 가
1 가 (1), (1)
(1), (2) 가 (3c)
(3), (3) (4), (2)
(4) (3) (5) (6)
(1) (3)
(1) (7)가 (2) (1)
(2) (3) (8)가 (3)
(3) (3a) (9)가 (6) (6a) (6b)
(6) (6a) (3)가 (4) (6a) (6b)
(6b) (4)가 (3)
(4)가 (2) (5) (3) (6) (6b)
가 (4) (3)
(8) (5) (6) (6a) (3)

0) (101), (2) (100) (102), (7) (10) (103)가 (100) (105), (11) (104), (5) (106), (10) (107), (13) (108)가 (108)가 (109) (20)가 (21) (21) (24) 가 (21) (24) (23) (21) (21) (24) (21) (6b) (70) (21) (6b) (21) (22) (40) (40) (40) (40) 가 (21) (22) (32)(33) (30) (30) 30) (40) (80) 가 (60) (80) (50) (51) (40) (55) (51) 5 (180) (22) (54) (52)(53) (51) (22) (40) (54) 5 (22) (54) (31a) (40) (41a) (52) (22) (30) (31b) (30) (54) (41b) (40) (80) (80) (20)가 (40) (60) 6 7 4 5 , 6 (20)가 (60) (80) (80) (22) (6b) ((22) (40) 40) (60) (22) (60) 8 (3) (S100) 가 (101) (3) (100) (100) (20)가 (5)가 (5) 가 (5) (100) (105) (5)가 (5) 가 (5) (S101-S102). (100) (13) (108) (2) 가 (108) (100) (13) (100) (2) (3) 가 (108) (100) (105) (60) (3) (105) (5) (S104). (100) (102) (3) 가 (105) (5) 가 (100) (S105), 가 (100) S104 S103 가 가 (100) (105) (3) 가 (3) (S106).

, (105) (100) (60) (105) (60) ,
 (105) (100) (60) (5) (60) 가
 6) (100) (11) (10) (S10
 7). (11) (100) (11) (10) (S10
 (105) (60) , (100) (3) (5)
 가 (60) (105) (3) (100) (S108). (5)
 (100) (S109), 가 S106, S107
 S108 S109 (107) (107) (100) (100) (S110)
 (10) (107) 가 (8) (107) (100) (S110)
 (100) (102) 가 가 가
 (S111), (100) 가 S110 가 , 가
 S112). (100) (105) (60) ()
 (105) (100) (3) (200) (5) (60)
 (105) (3) (5) (5) (S201). (5) (60)
 (100) (S202), 가 S201 가
 (S203). (105) , (105) (5) (5)
 (200) (300) (105) , (105)
 (100) (5) (60) (105) (105)
 (S301). (100) (3) (3) (105)
 , (105) (5) (60) (105)
 (108) (3) (S302), (100) (60) (3)
 (108) (108) (S303), (13) (100) (3)
 가 S301 가 (S304),
 S304 (300) (400) .
 (100) (3) (5) (5) (60)
 (105) (3) (5) (S401). (5) (60)
 (100) (S402), 가 S401 가
 (S403). (105) , (105) (5) (5)
 (400) (500) .
 (100) (5) (60) (105) , (105)
 (S501). (3) 가
 (100) (108) (100) (108) ,
 (100) (3) (13) 가 (2) (105) (S502), ()

105) (5) (60) (3) 가 가 가 S502
(S503), (100) (102) 가 가 가 S502
가 S504 가 가 가 (100)
(5) (105) (105) (100) (100)
(100) (3) (11) (105) (S505).
(105) (100) (3) (5) (11) (60) (S506)
(100) 가 S505 S5
(S507), S505 S5
06 S507 (100)
(11) (107) (100) (10) (107) 가 (8)
(S508). (102) (S509),
가 (100) S508 가 , 가 (105) (5)
(100) (60) (105) (S510). (S511), (1
(100) (2) (3)
05) , (105) (5) (S512). (60)
(100) (3) 가 S512 가
(S513), (105) S501 가 (5) (600)
S514) S511 가 (2) (600)
(100) (105) (5) (5) (S601).
5) (100) (60) (3) 가 S601 가
(S602), (105) 가 (100) (105) (5)
(S603). 가 (100) (105) (5)
(105) 가 (S604). , 가 가

(57)

1.

2

;

1

;

2.

.

;

;

,

3.

2

,

4.

.

5.

.

,

2

;

1

;

;

;

;

6.

5

,

.

1

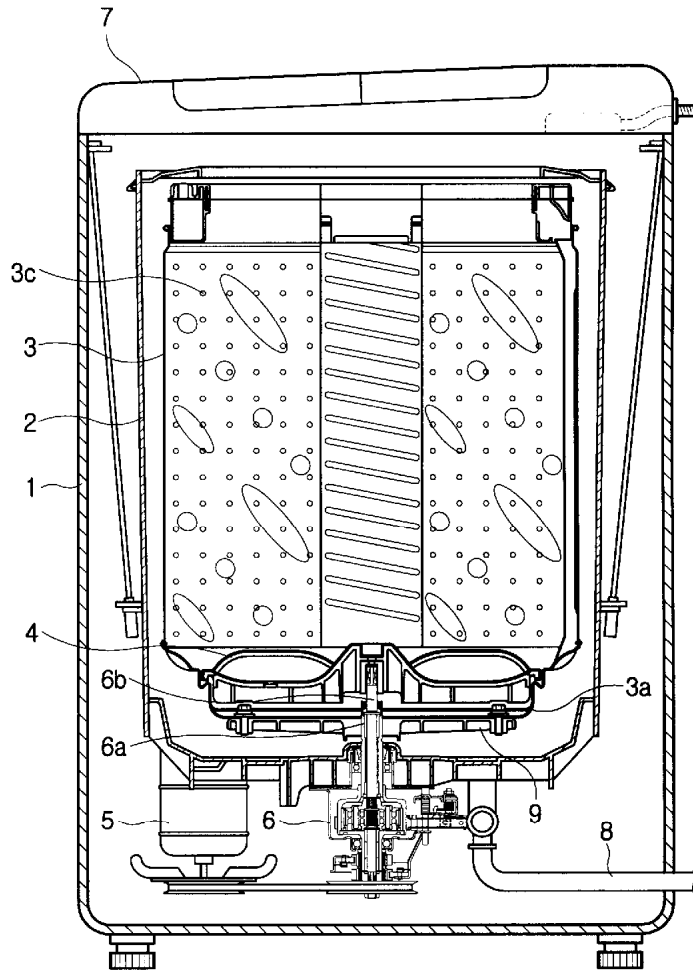

2a

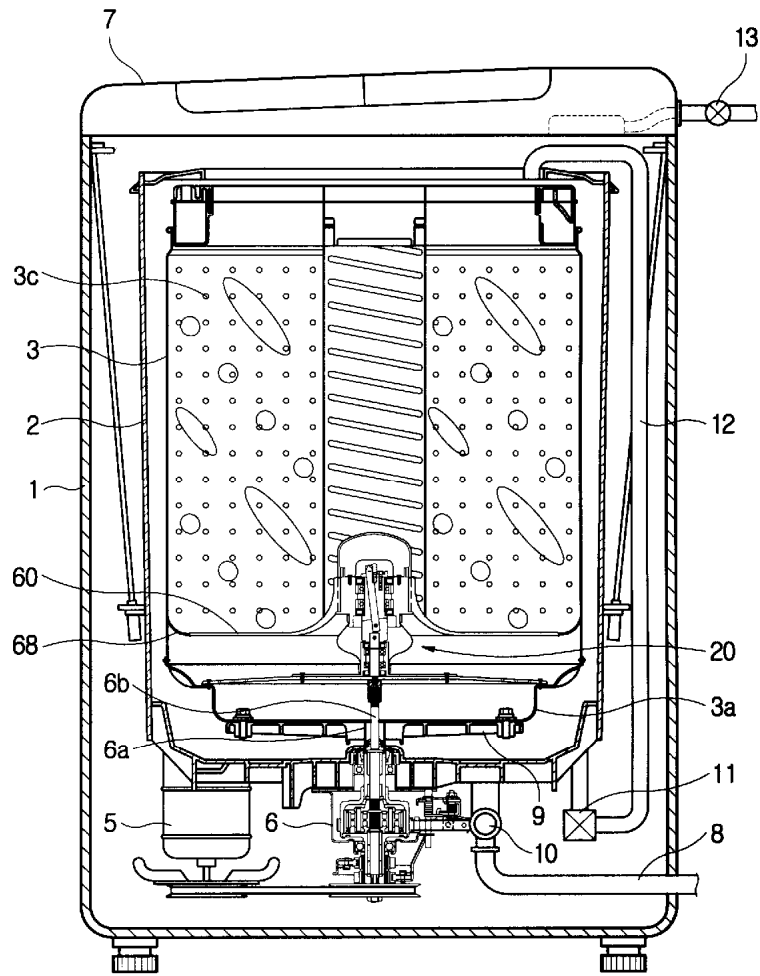

4

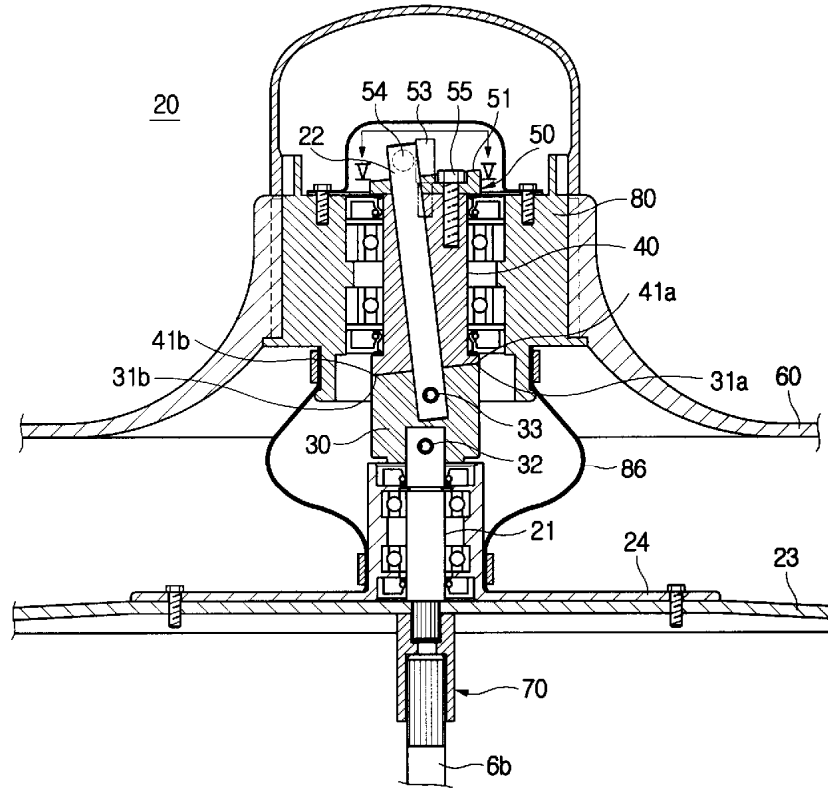

5

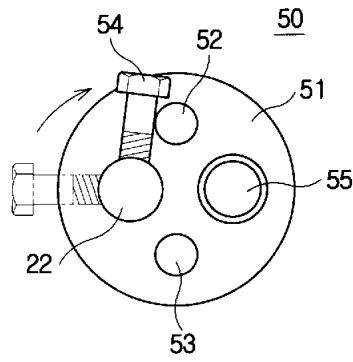

6

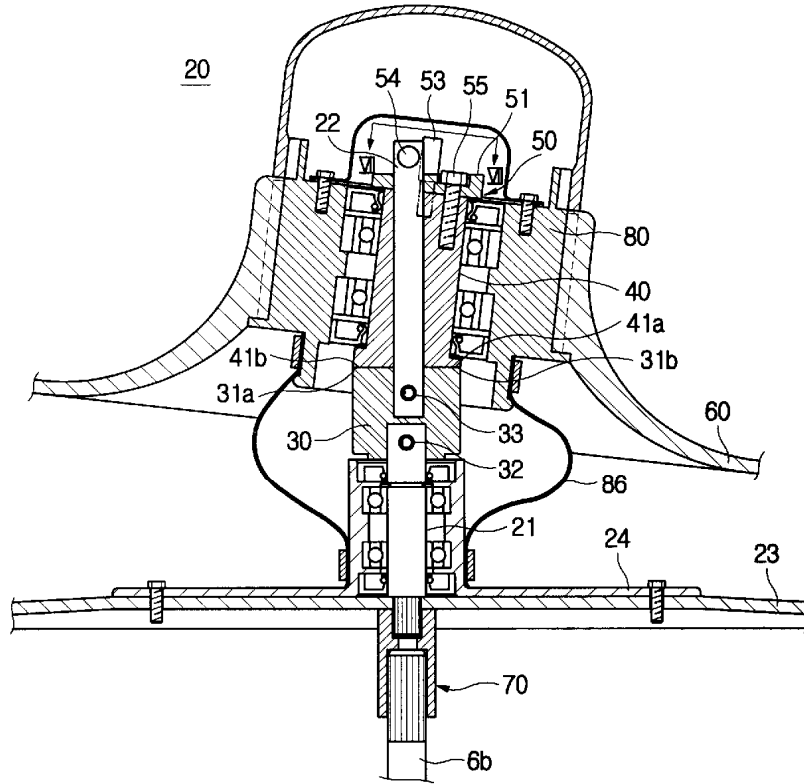

7

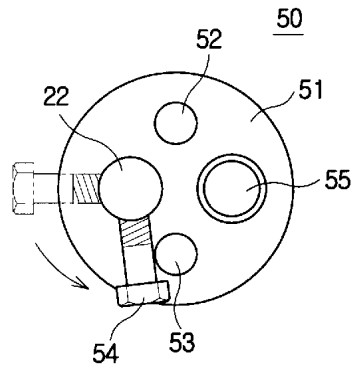

8a

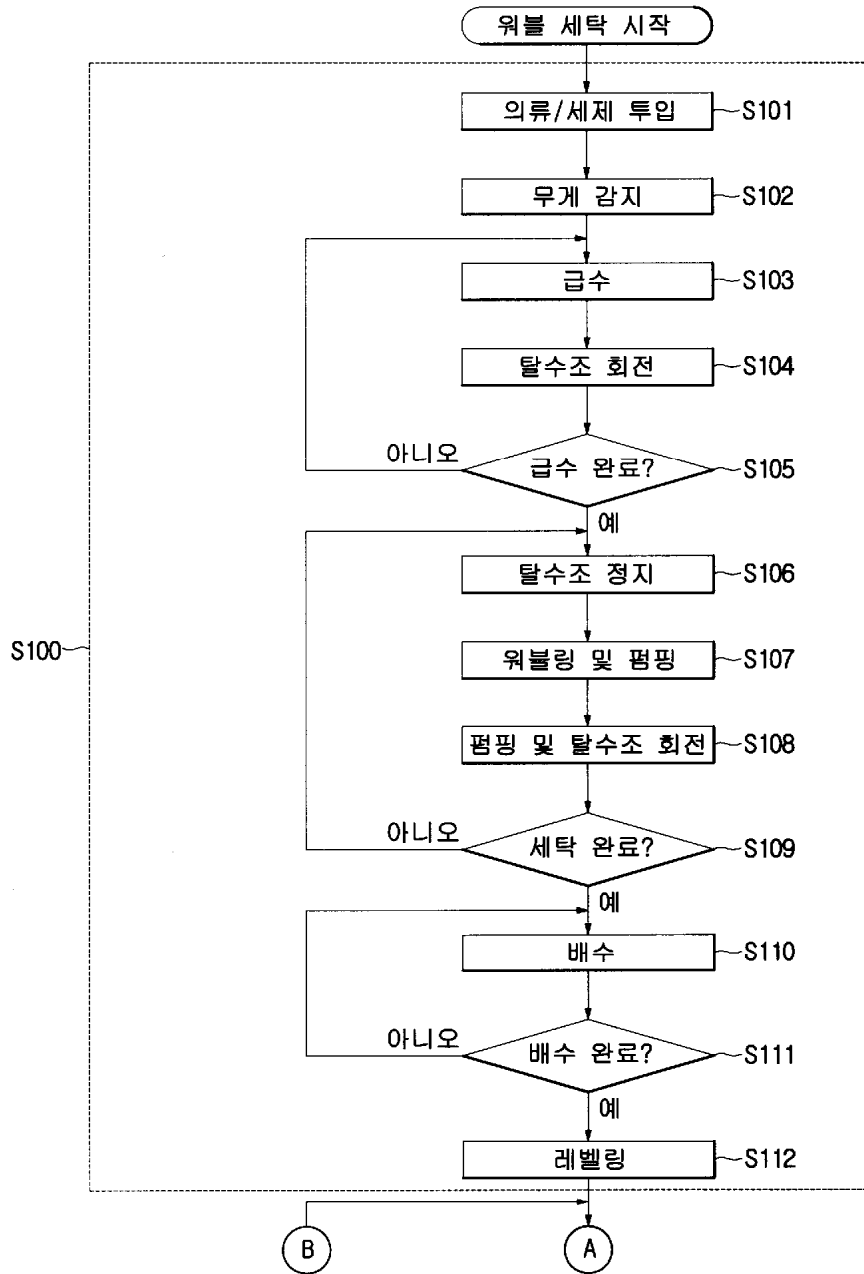

8b

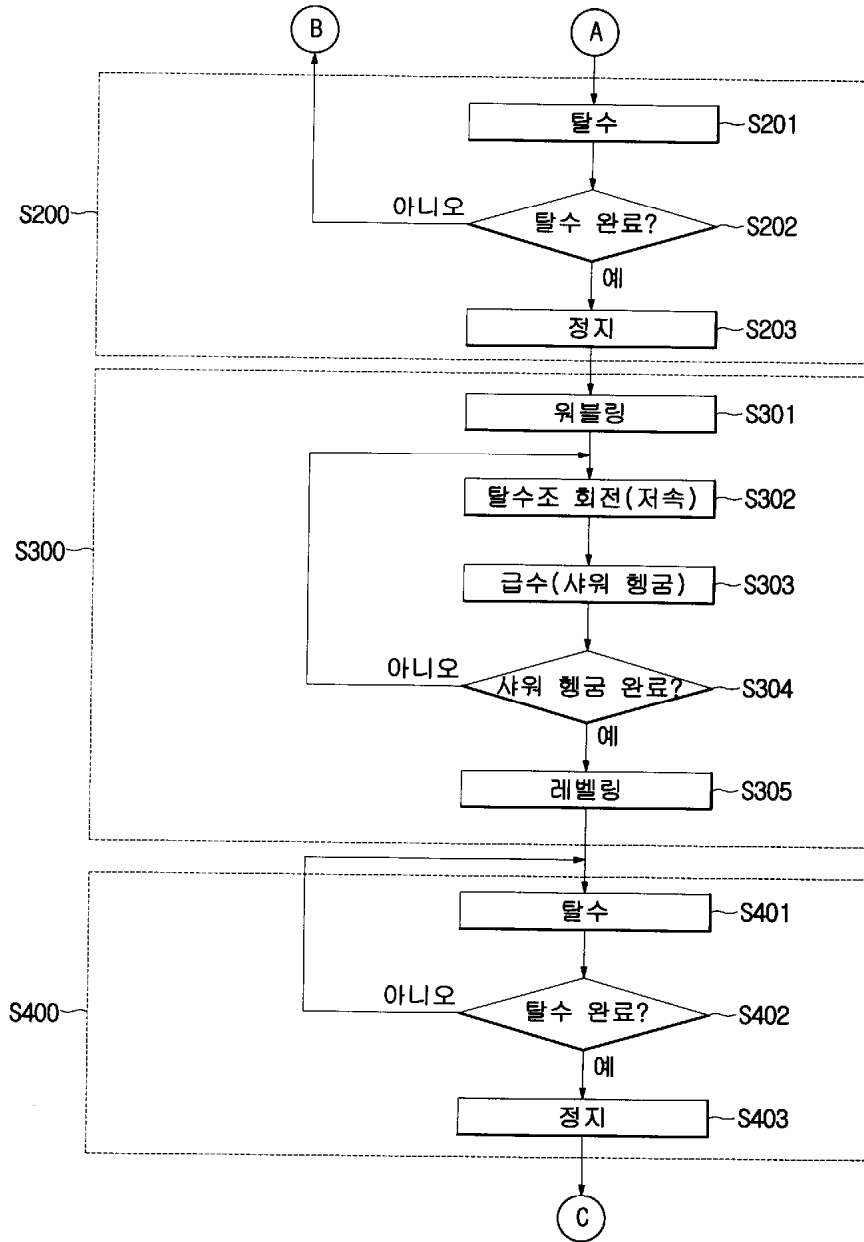

8c

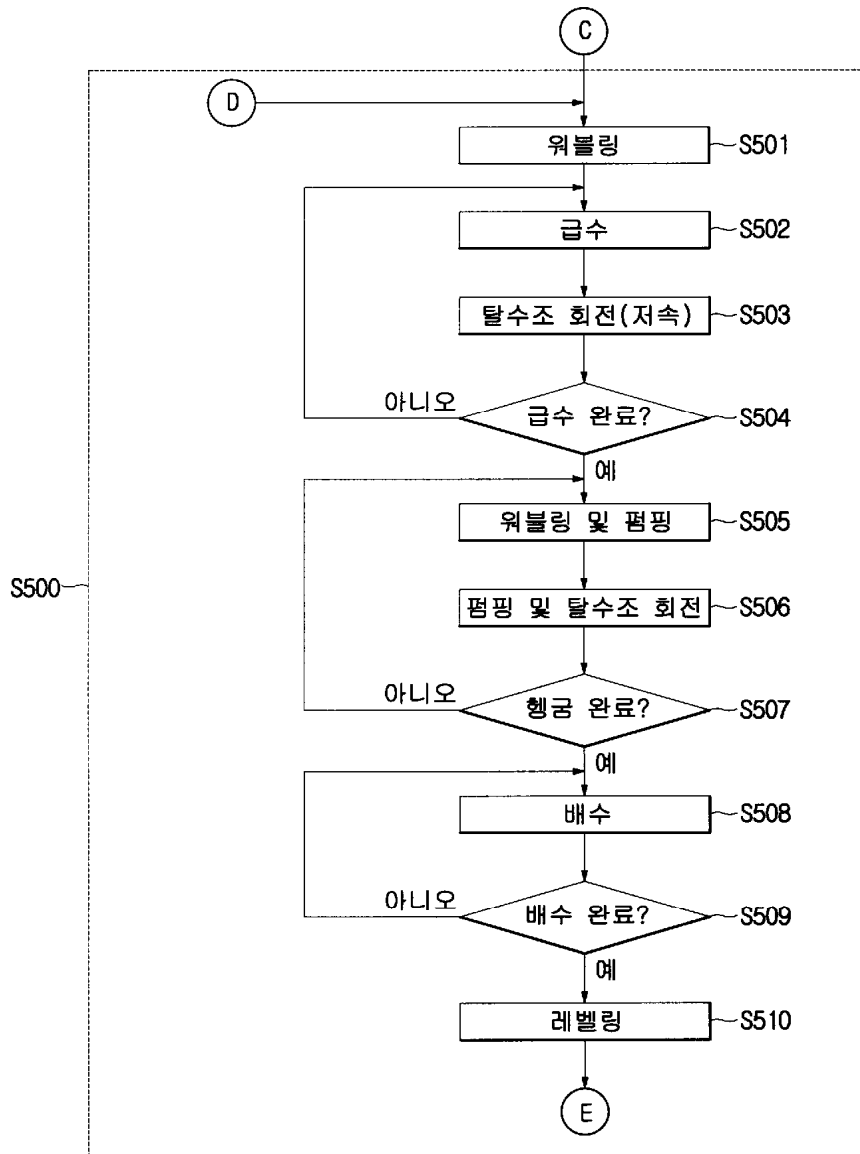

8d

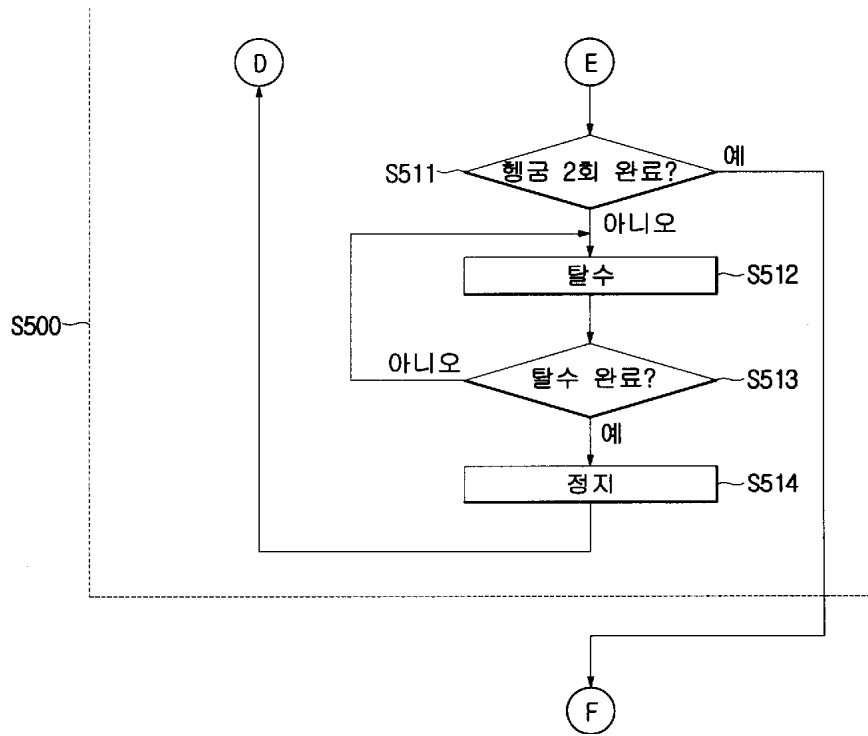

8e

