



US 20070017172A1

(19) **United States**

(12) **Patent Application Publication**
Kennedy et al.

(10) **Pub. No.: US 2007/0017172 A1**

(43) **Pub. Date: Jan. 25, 2007**

(54) **SPACE DIVISION SYSTEM WITH TECHNOLOGY**

Related U.S. Application Data

(76) Inventors: **Sheila Kennedy**, Boston, MA (US);
Bill Chen-Haun Yen, Bellevue, WA (US); **Joseph Chi-Chen Ho**, Diamond Bar, CA (US); **Senan Choe**, Bethesda, MD (US); **Robert W. Insalaco**, Holland, MI (US); **W. Daniel Hillis**, Encino, CA (US); **Russel Howe**, Glendale, CA (US); **Kenneth Munsch**, Holland, MI (US)

(60) Provisional application No. 60/408,011, filed on Sep. 4, 2002.

Publication Classification

(51) **Int. Cl.**
E04H 1/00 (2006.01)
E04H 14/00 (2006.01)
(52) **U.S. Cl.** **52/238.1; 52/238.1**

Correspondence Address:
VARNUM, RIDDERING, SCHMIDT & HOWLETT LLP
333 BRIDGE STREET, NW
P.O. BOX 352
GRAND RAPIDS, MI 49501-0352 (US)

ABSTRACT

A space division system (100) is disclosed, with the space division system (100) incorporating technology. The space division system (100) is disclosed as having a space divider (102) vertically suspended from a rail system (104). The rail system (104) includes a rail (106) with a pair of hanger clips (108) releasably secured to the rail (106) and capable of being moved along a continuum of the length of the rail (106). In one embodiment, the space divider (102) includes a main body (114) consisting of an opaque fabric. Associated with the main body (114) is lighting technology including a series of LED lights (116). Arrow lights (118) may be activated in an appropriate manner for emergency or other purposes. Color changing is also provided for purposes of wayfinding, signaling occupant activities or other external or internal circumstances.

(21) Appl. No.: **10/526,505**
(22) PCT Filed: **Sep. 4, 2003**
(86) PCT No.: **PCT/US03/27747**
§ 371(c)(1),
(2), (4) Date: **Jun. 7, 2006**

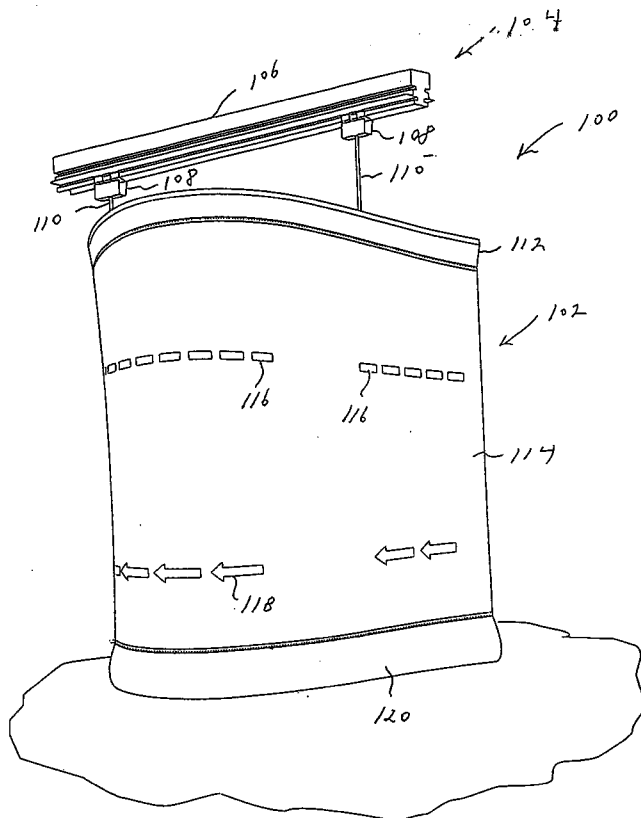

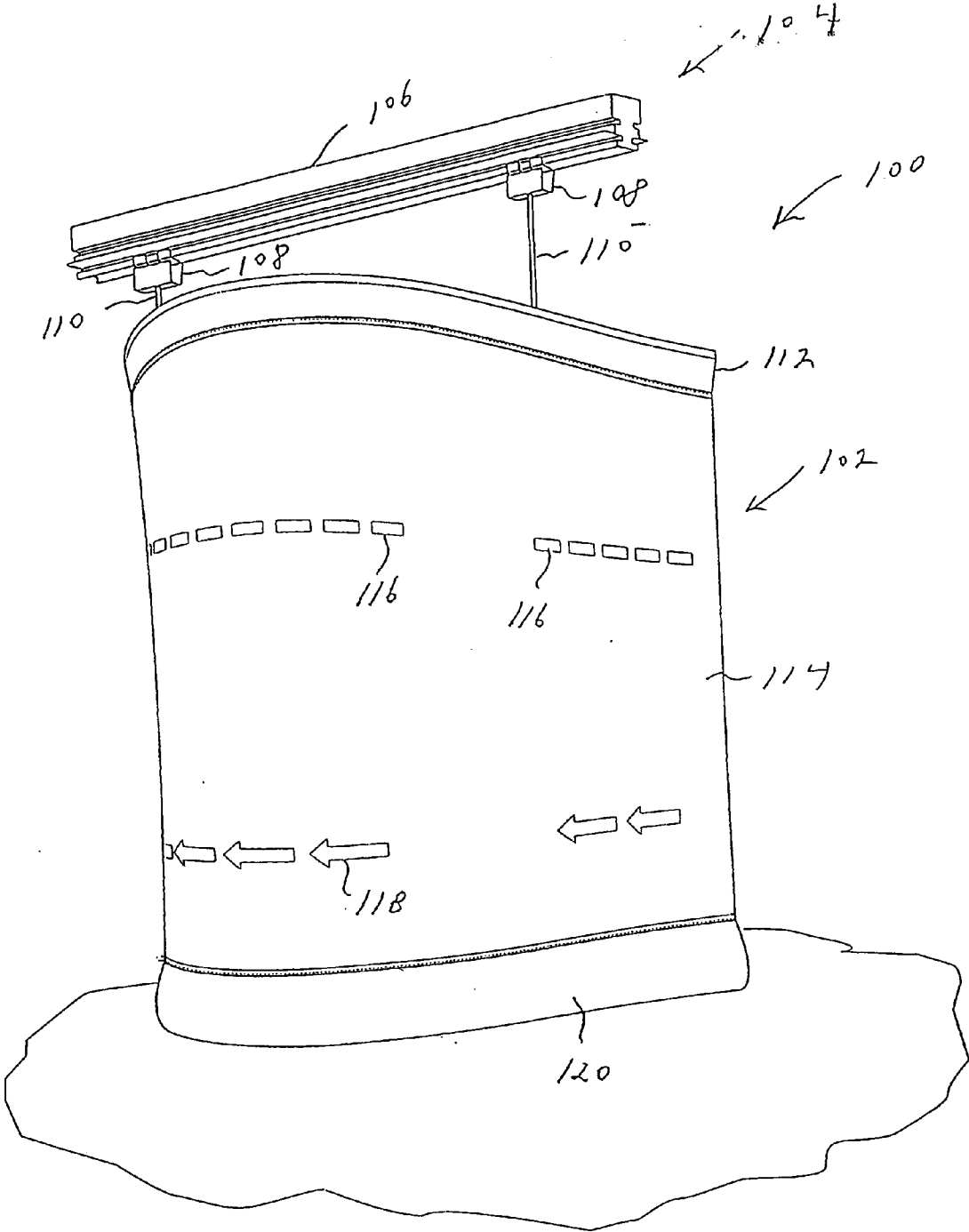

Fig. 1

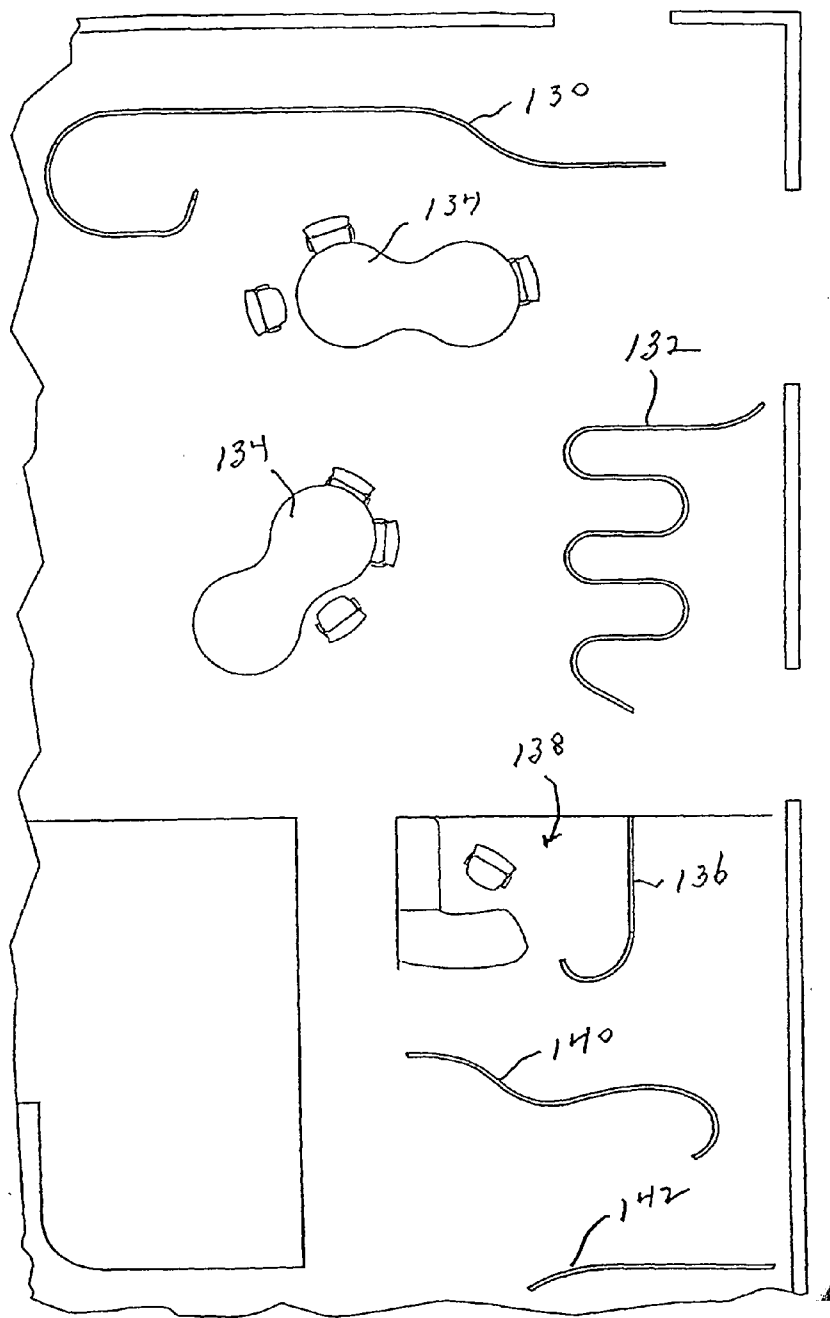

Fig. 2

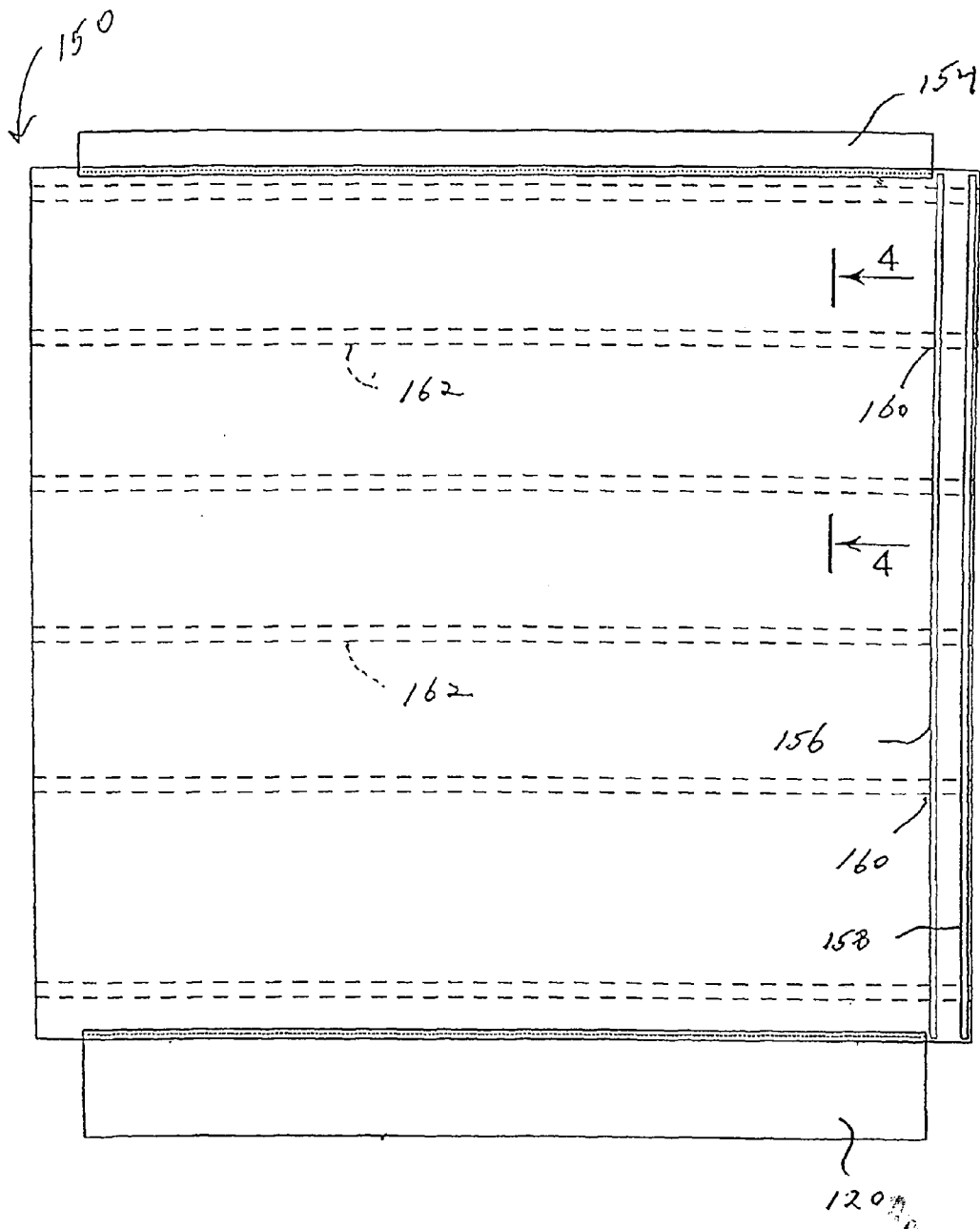

Fig. 3

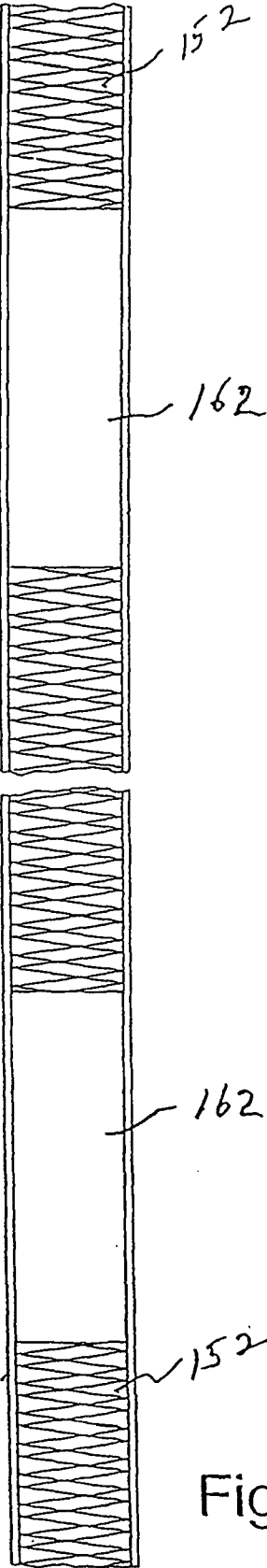

Fig. 4

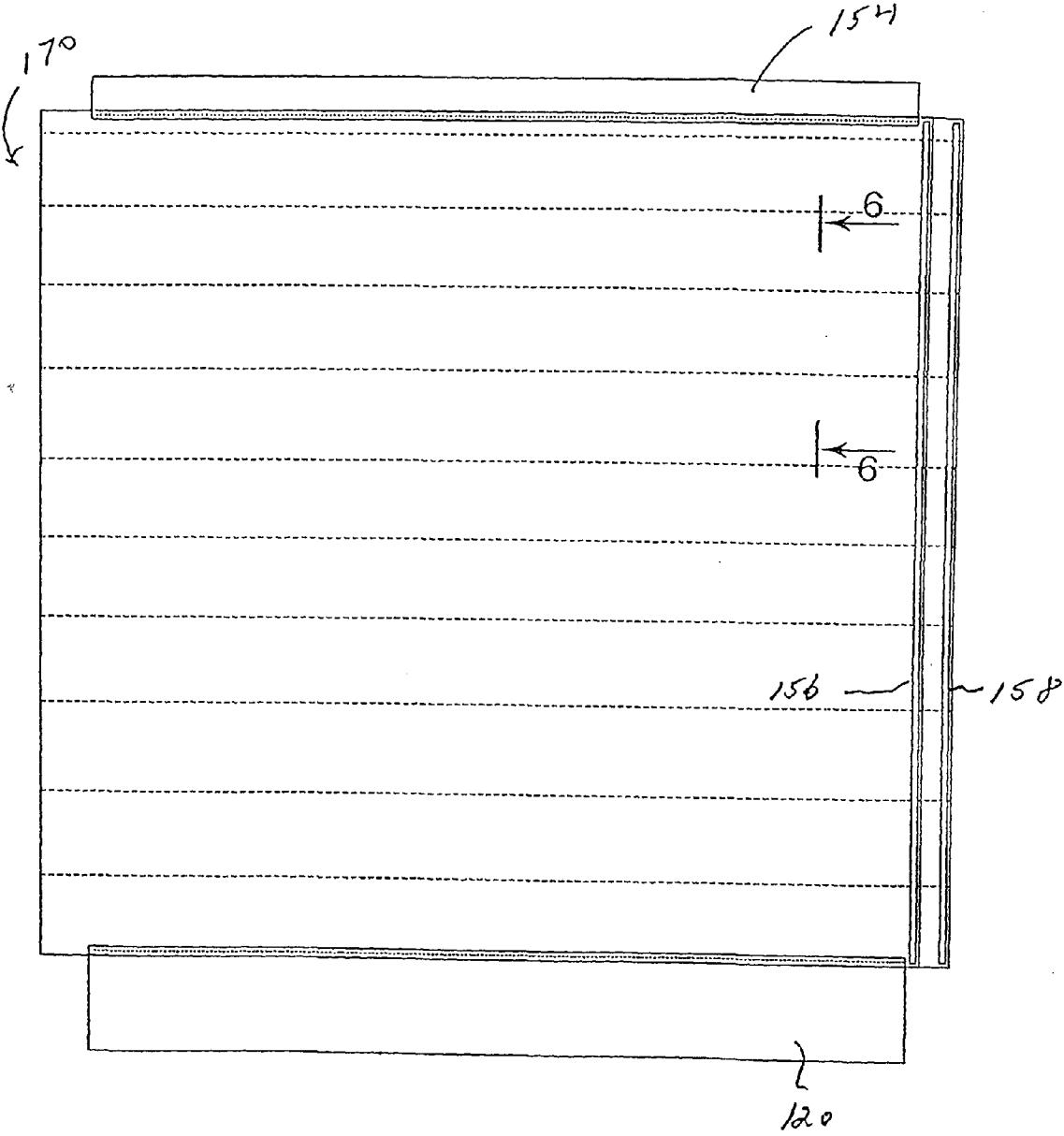

Fig. 5

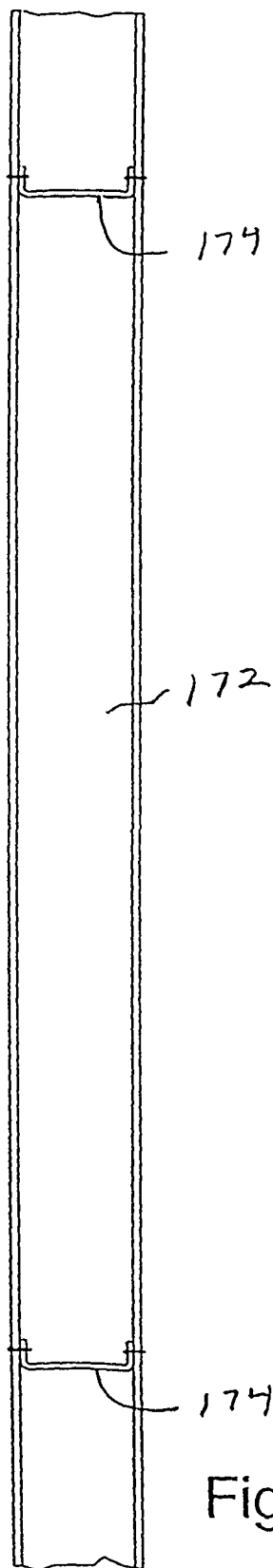

Fig. 6

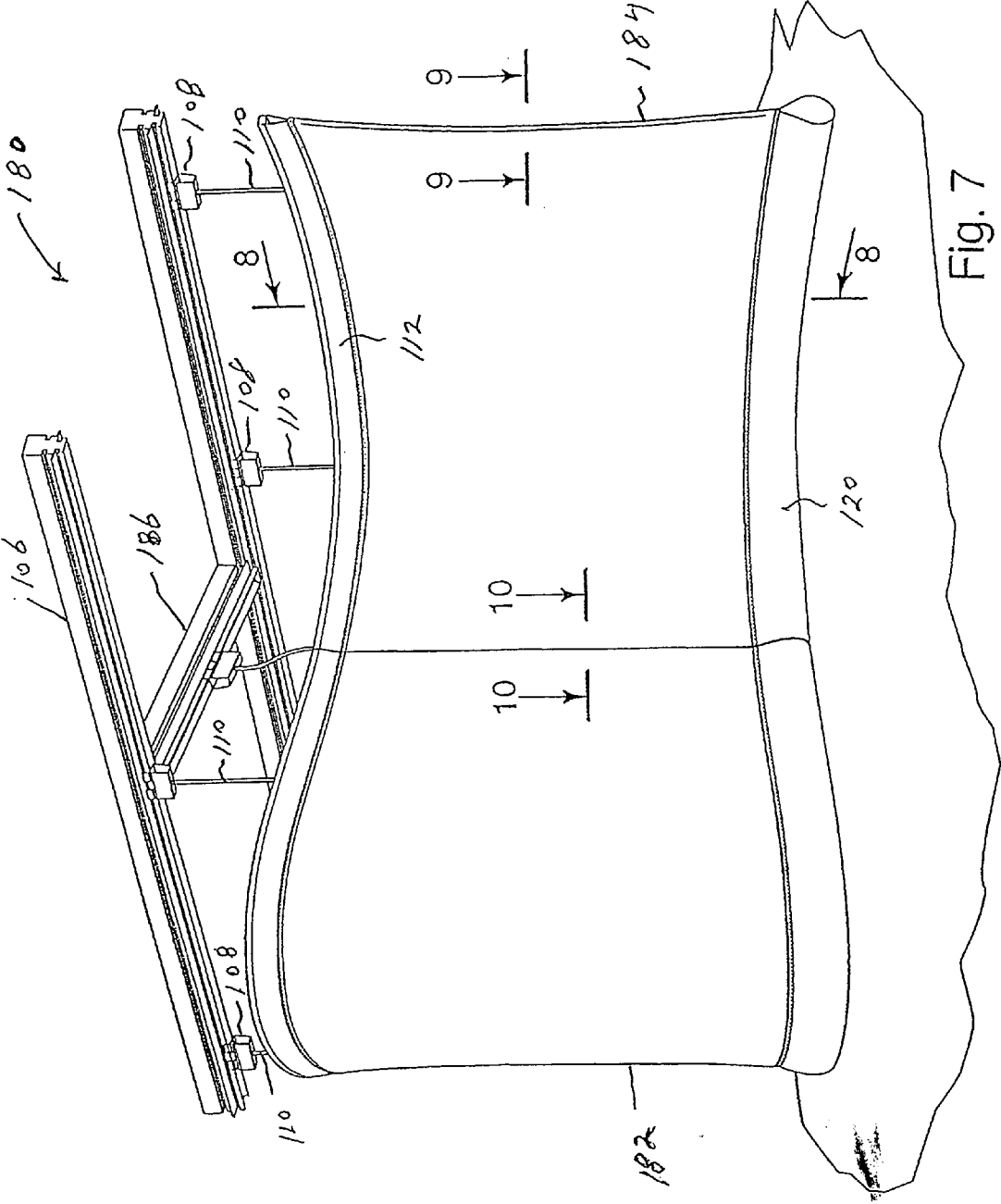

Fig. 7

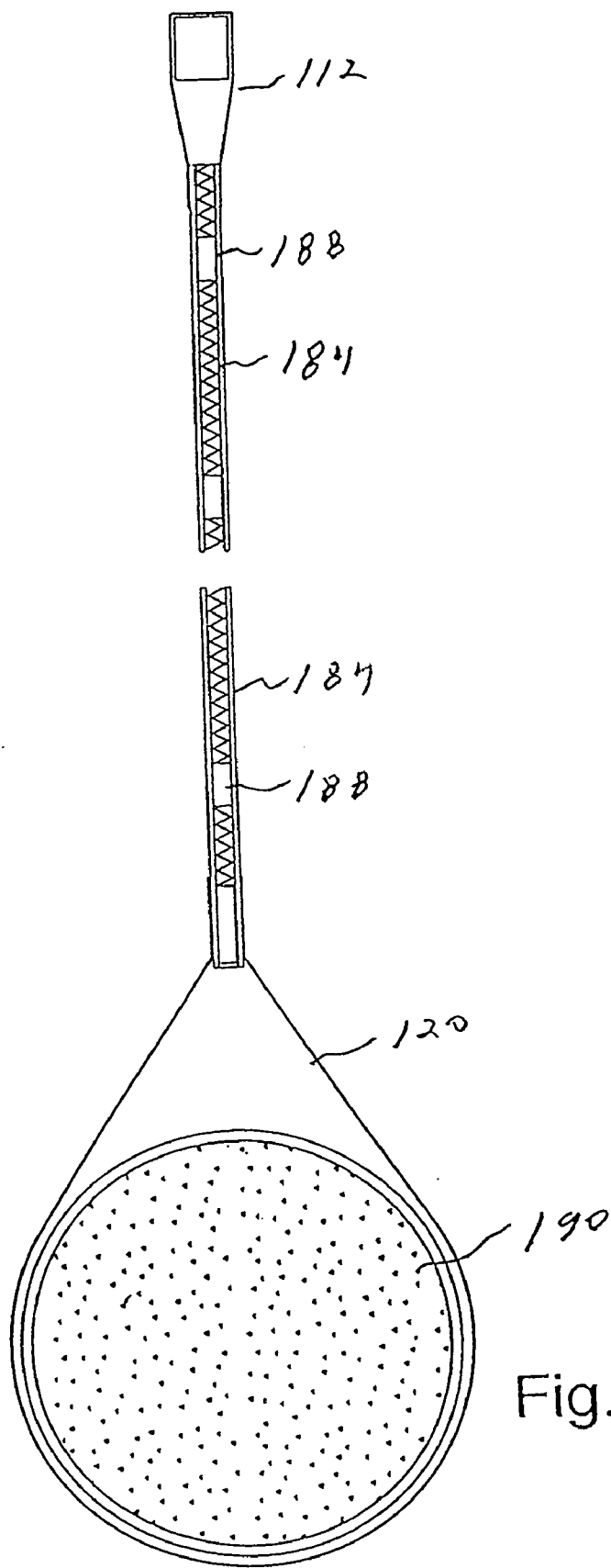

Fig. 8

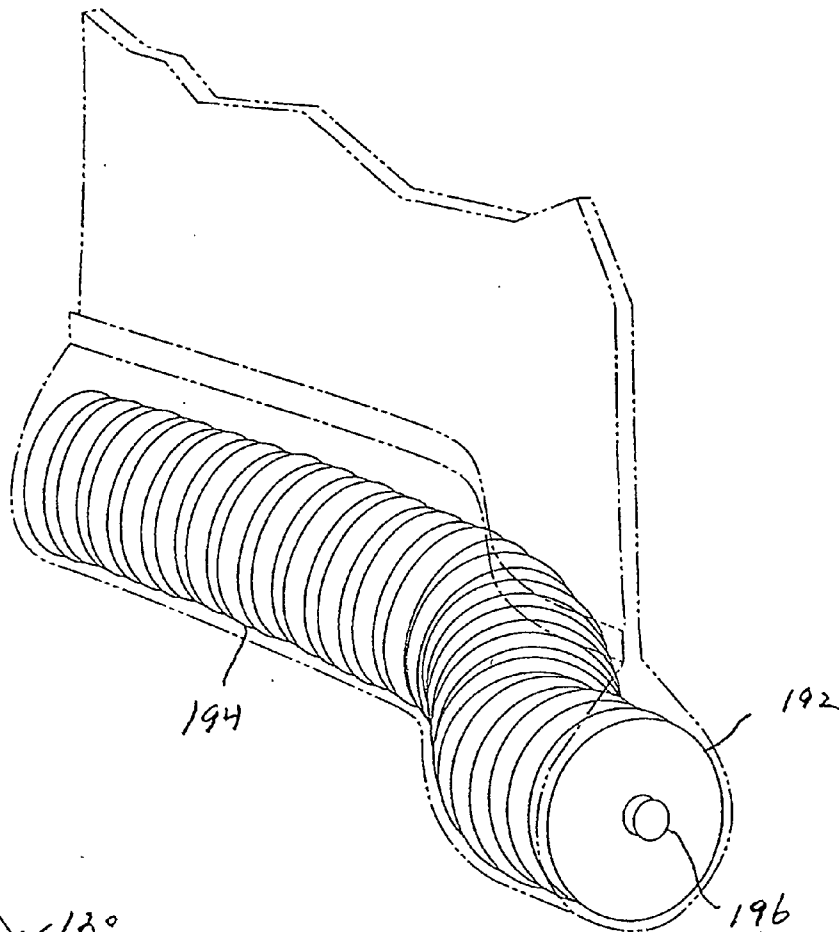
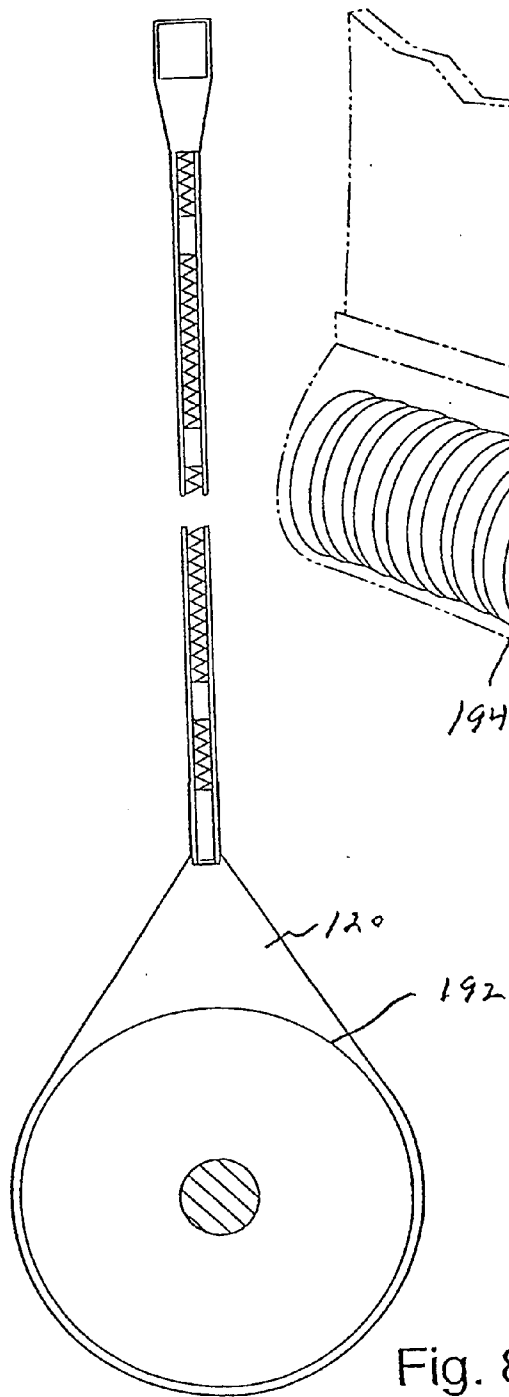

Fig. 8B

Fig. 8A

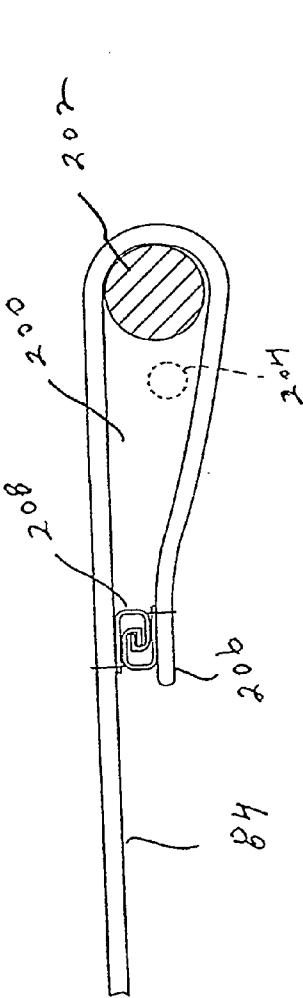

Fig. 9

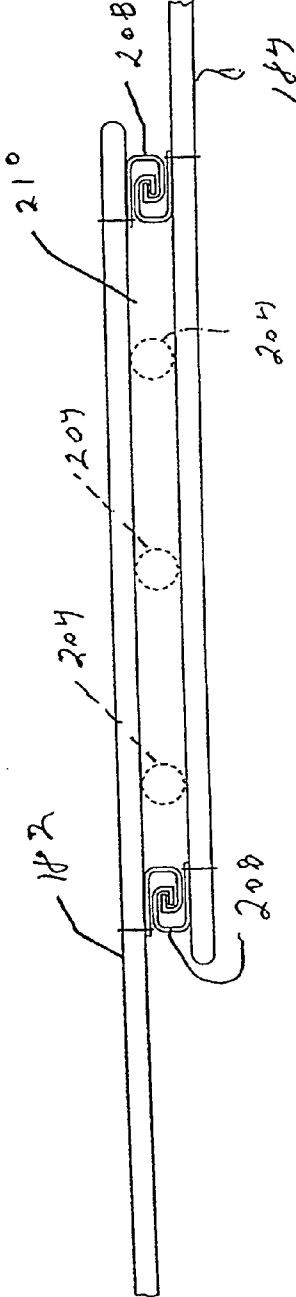

Fig. 10

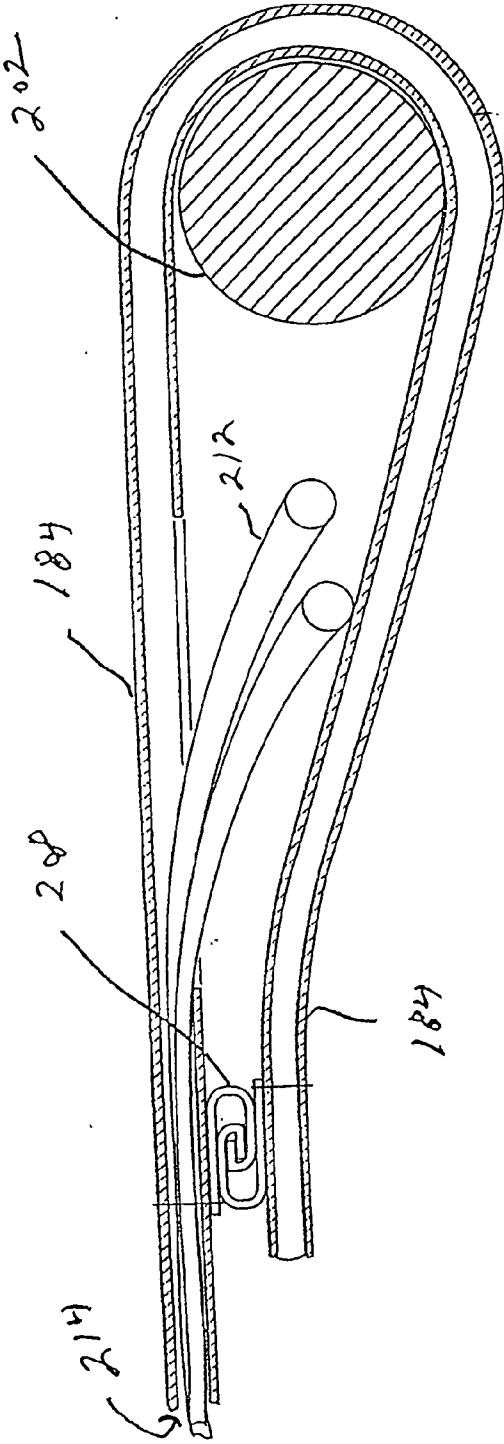

Fig. 11

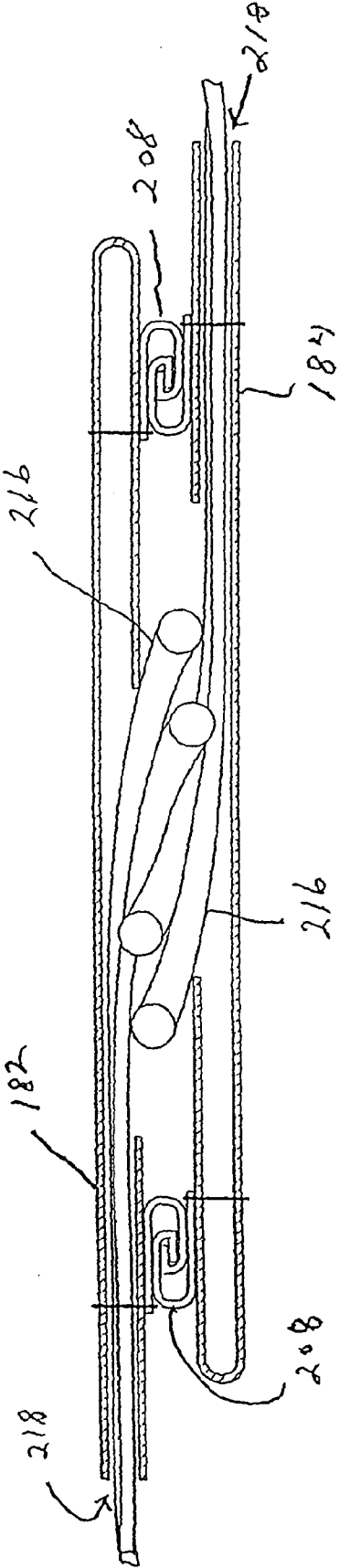

Fig. 12

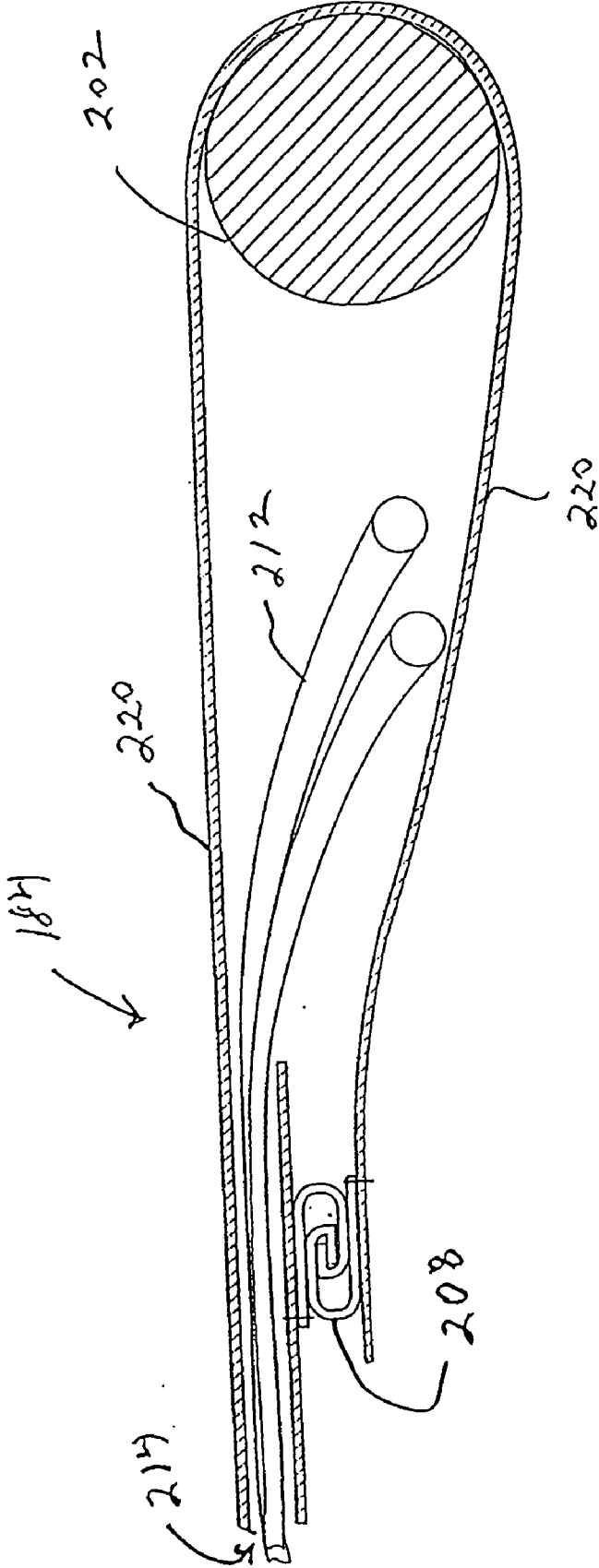

Fig. 13

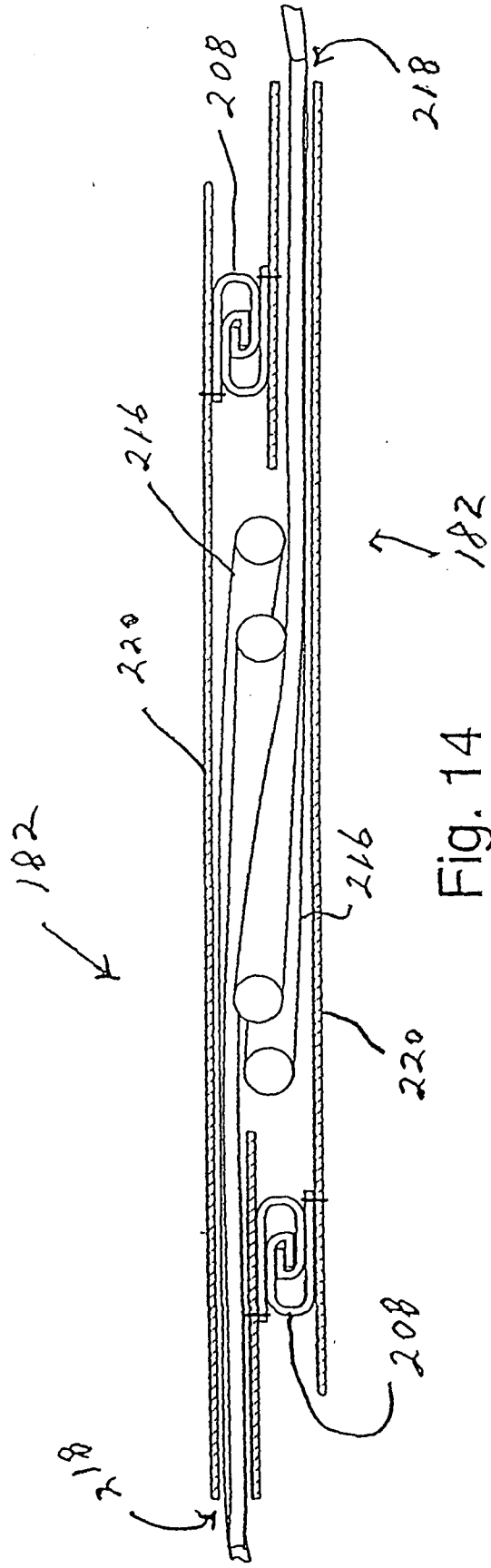

Fig. 14

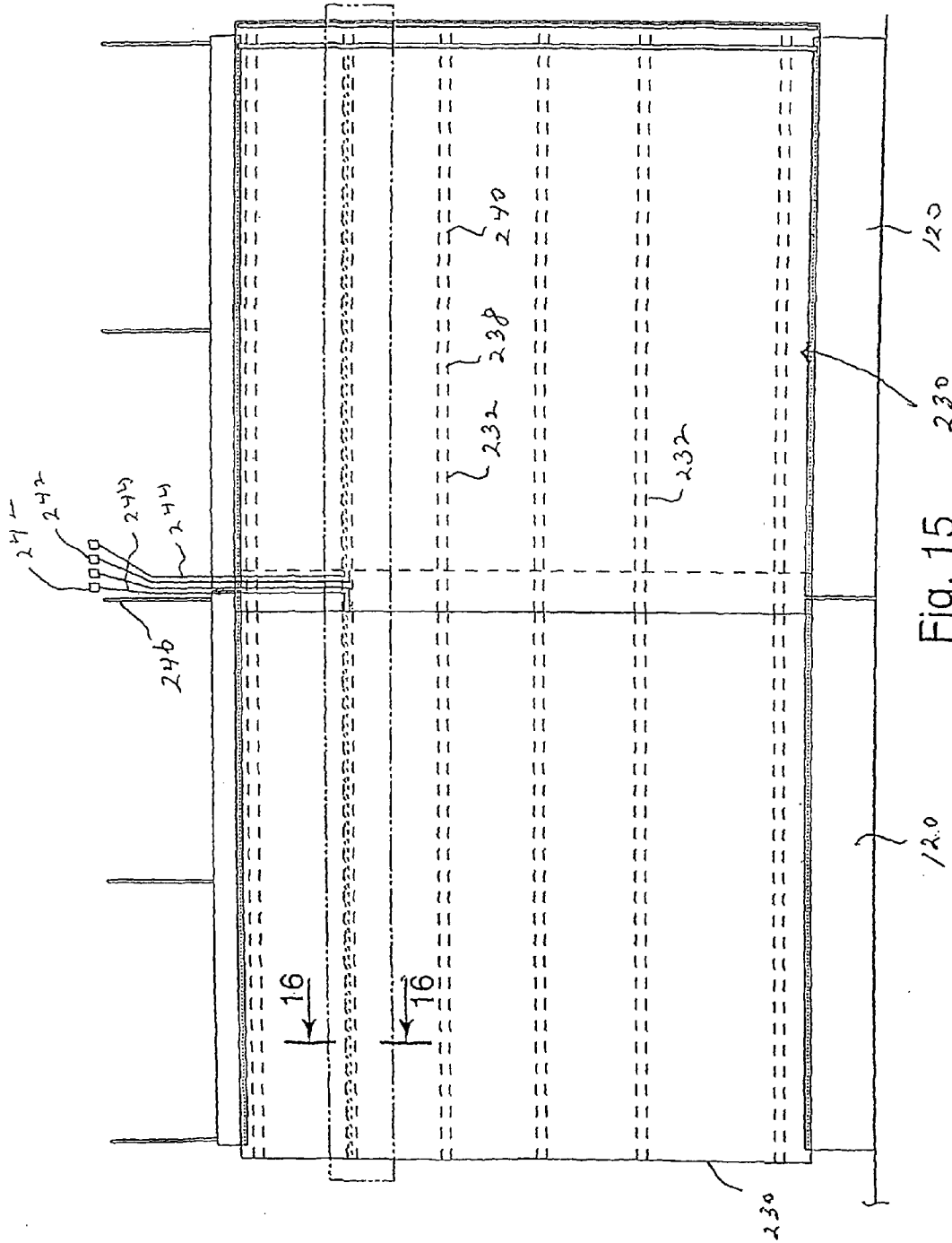

Fig. 15

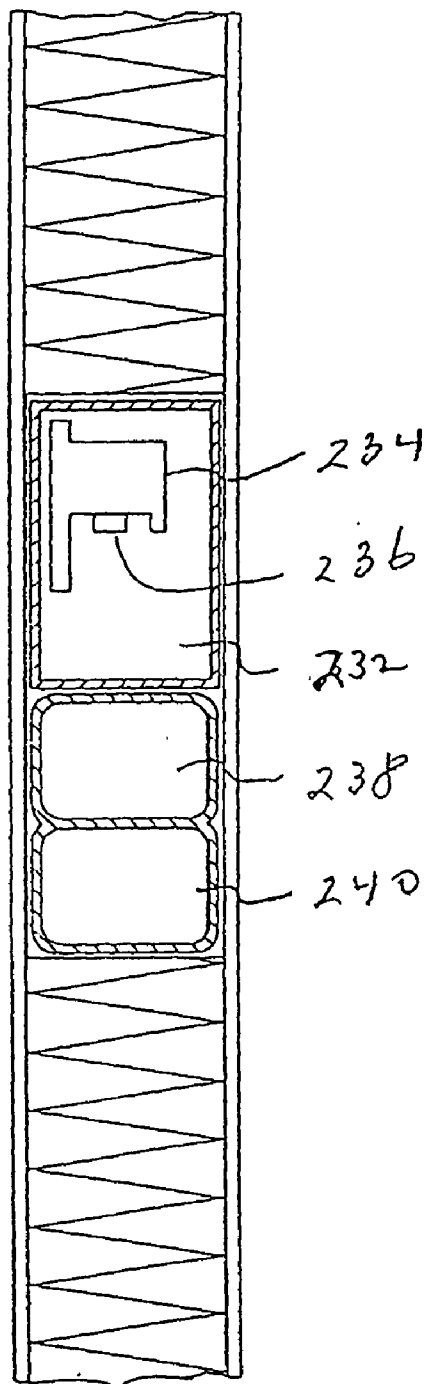

Fig. 16

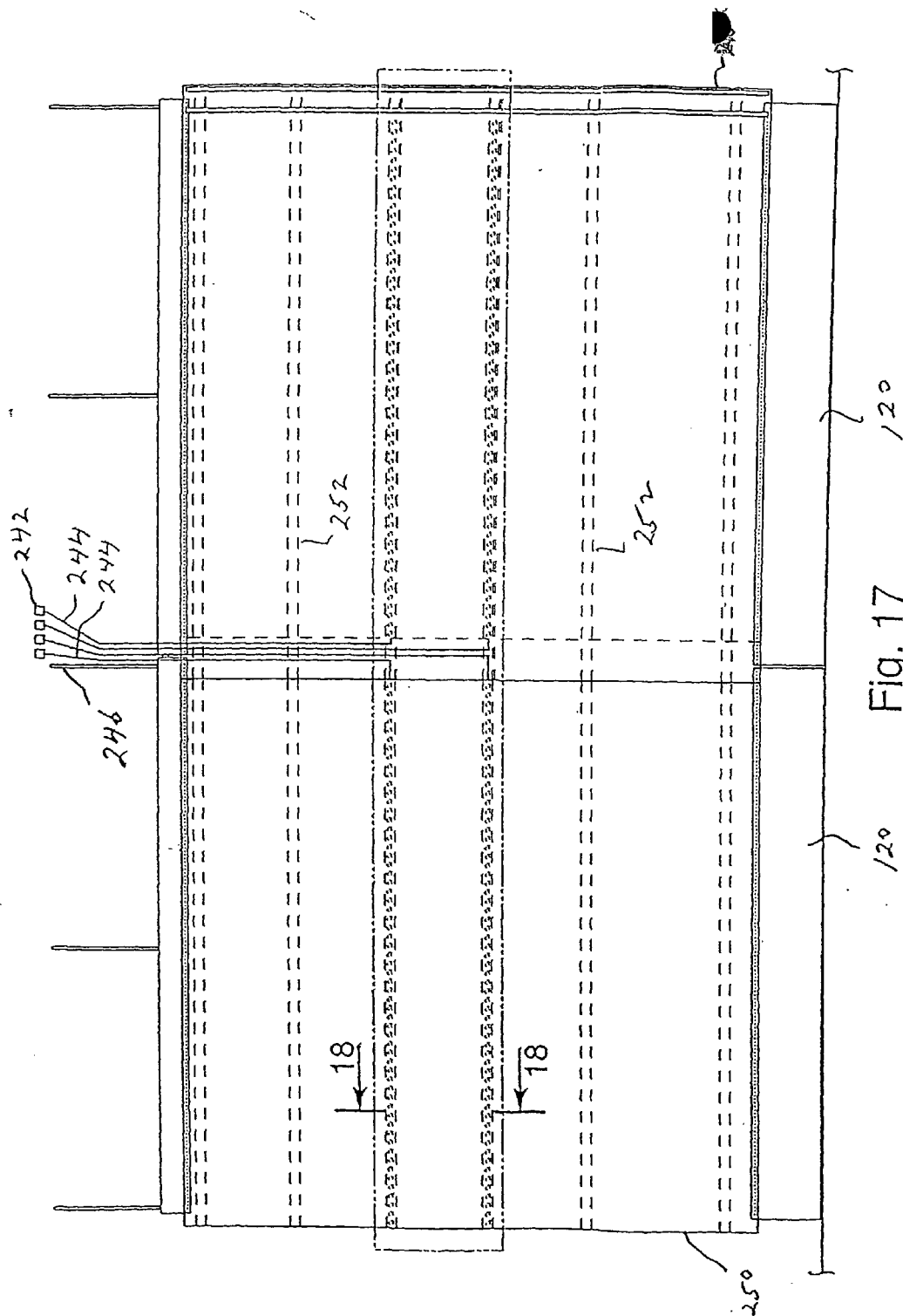

Fig. 17

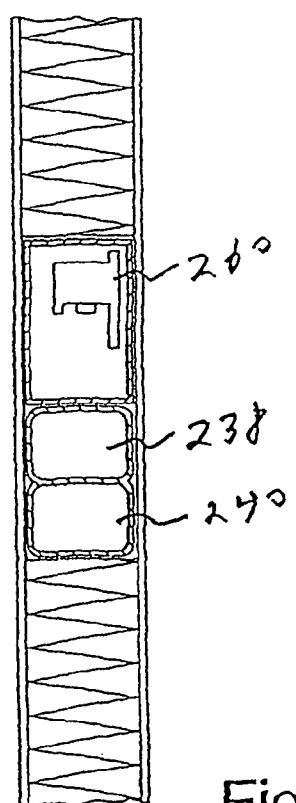
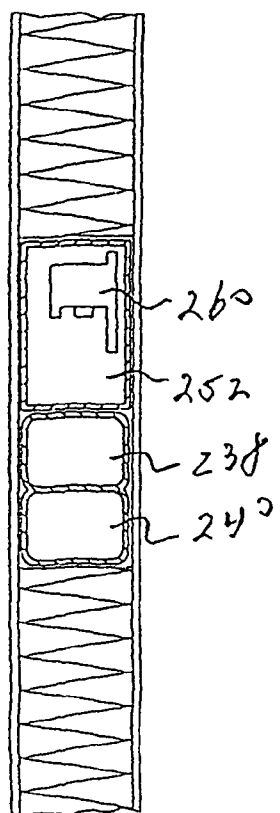

Fig. 18

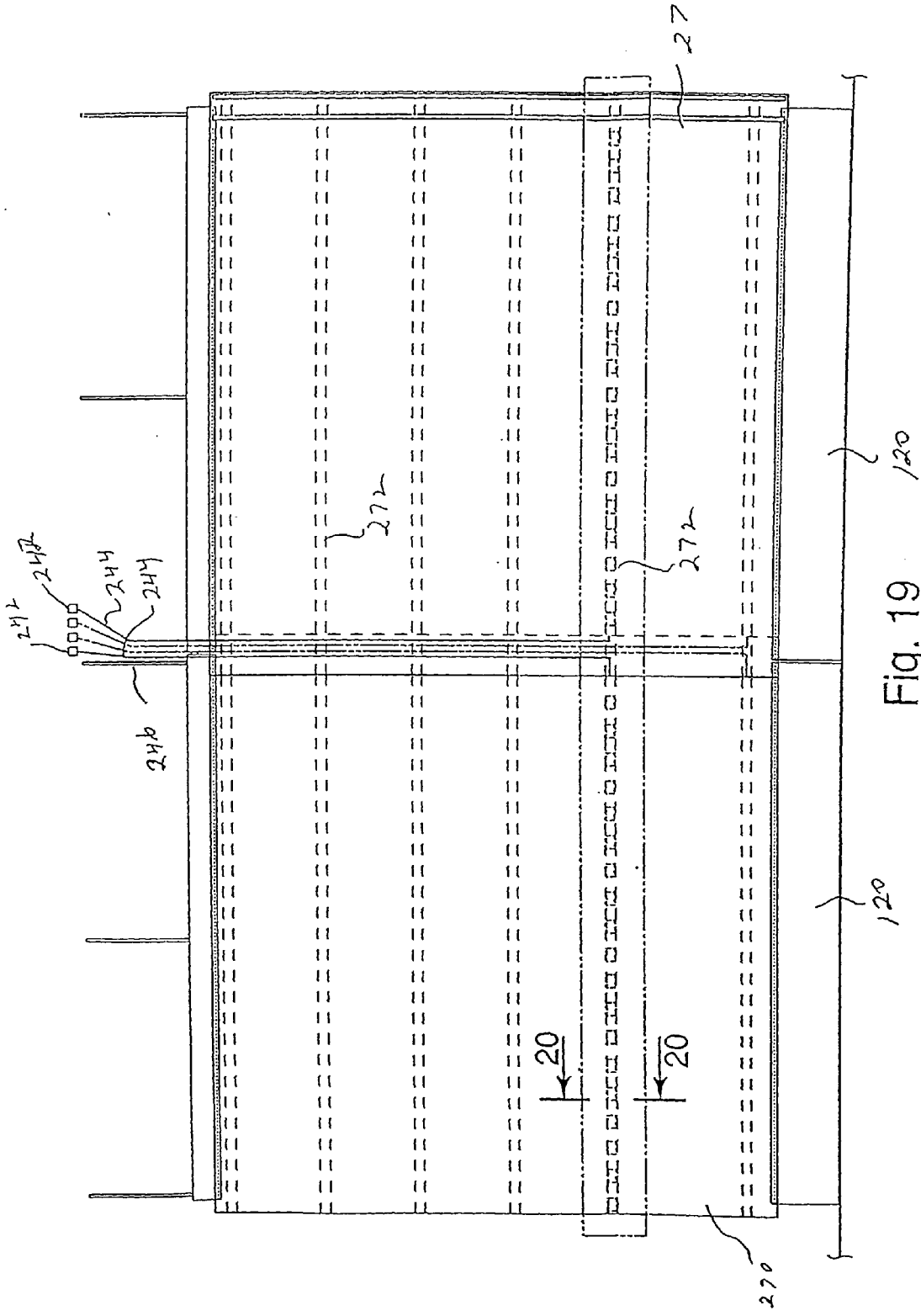

Fig. 19

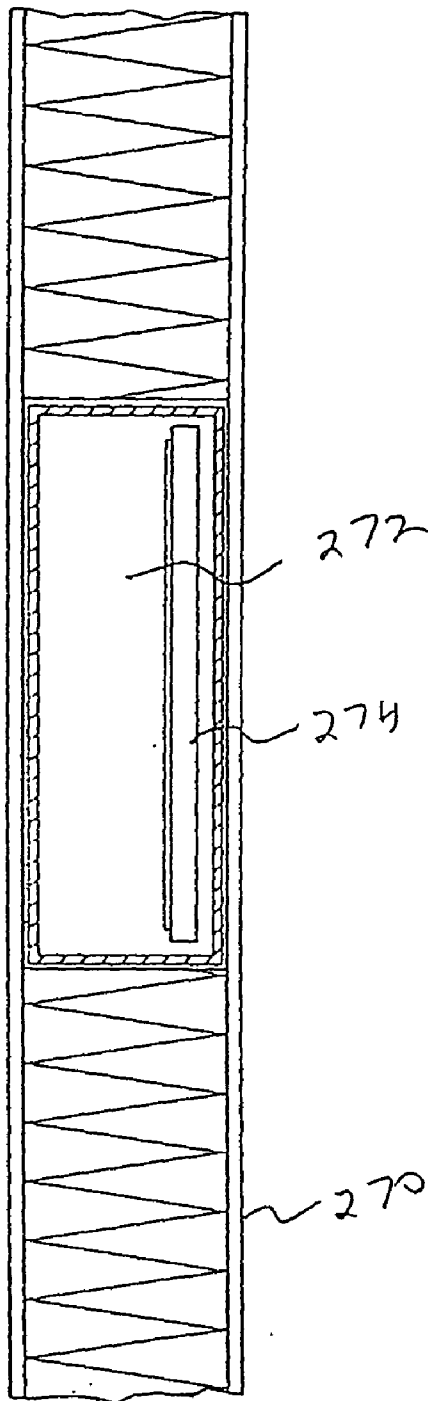

Fig. 20

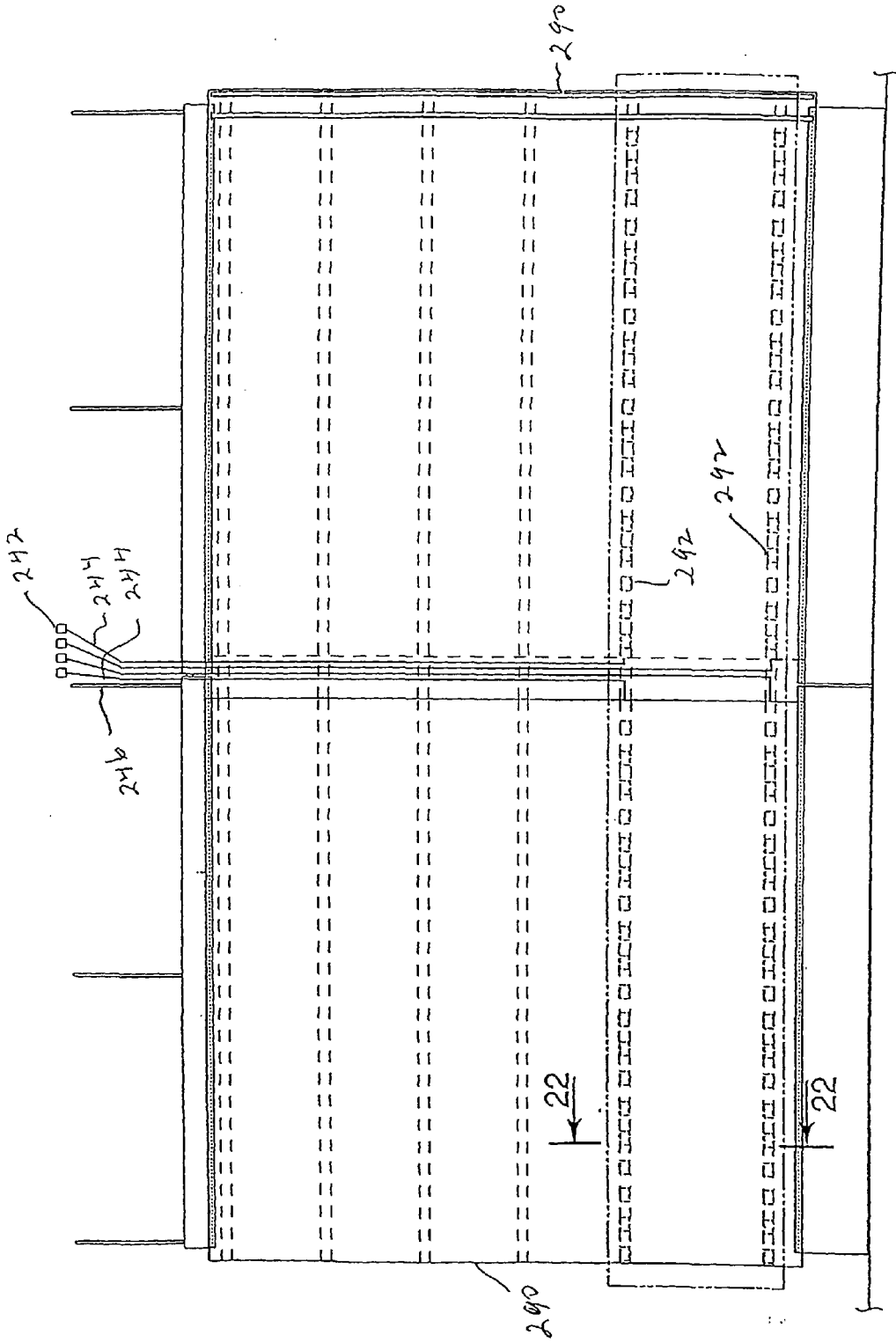
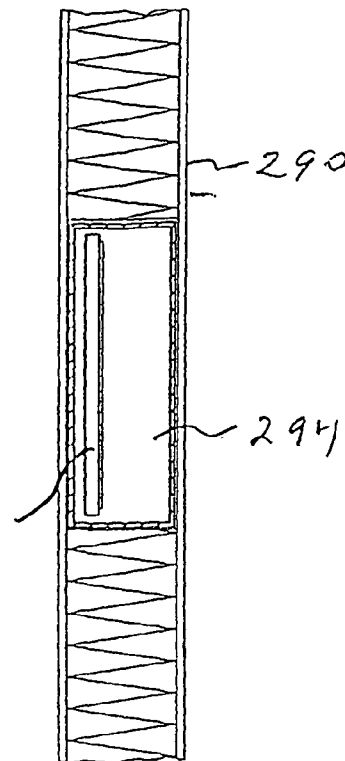
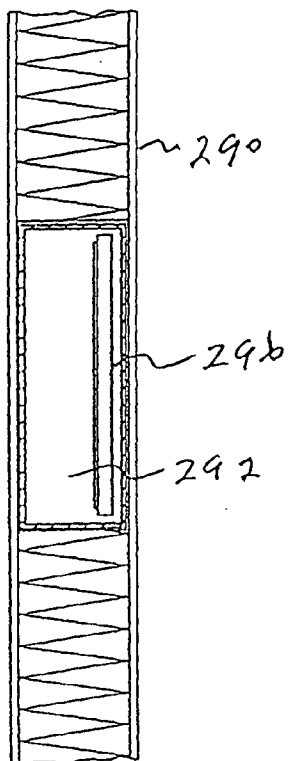

Fig. 21



298

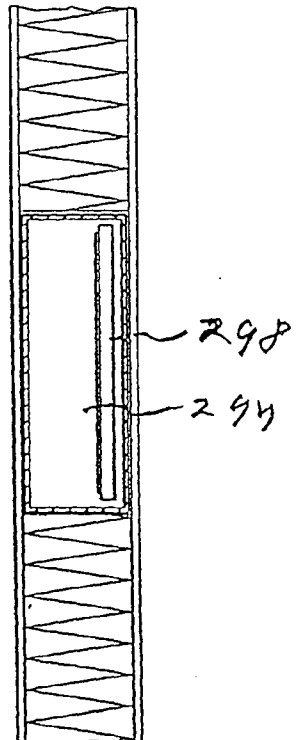
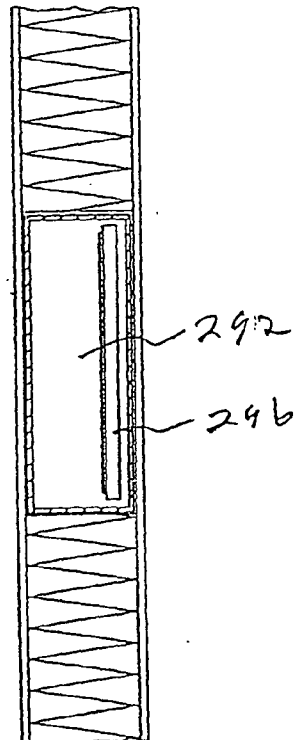

Fig. 22

Fig. 23

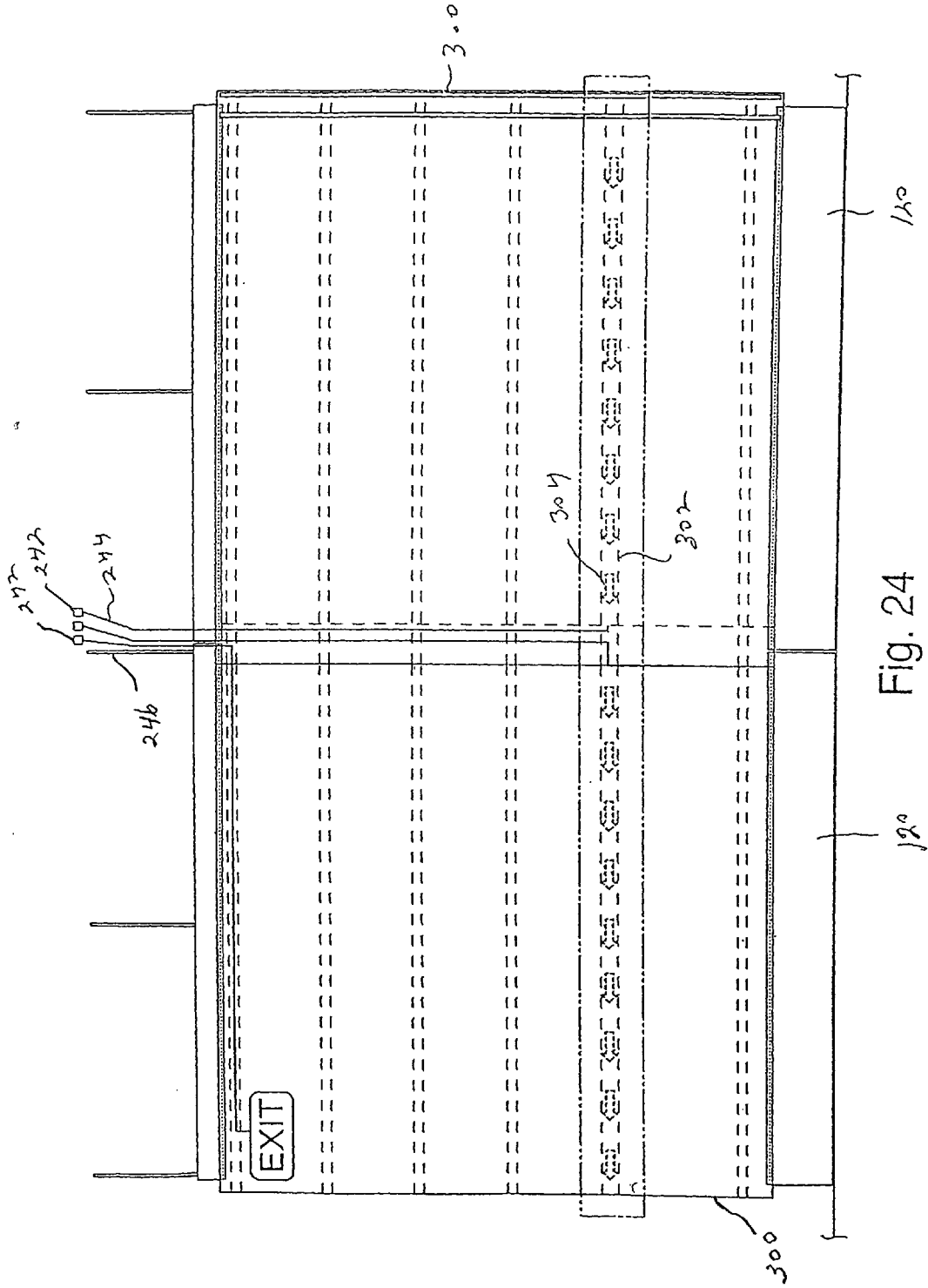

Fig. 24

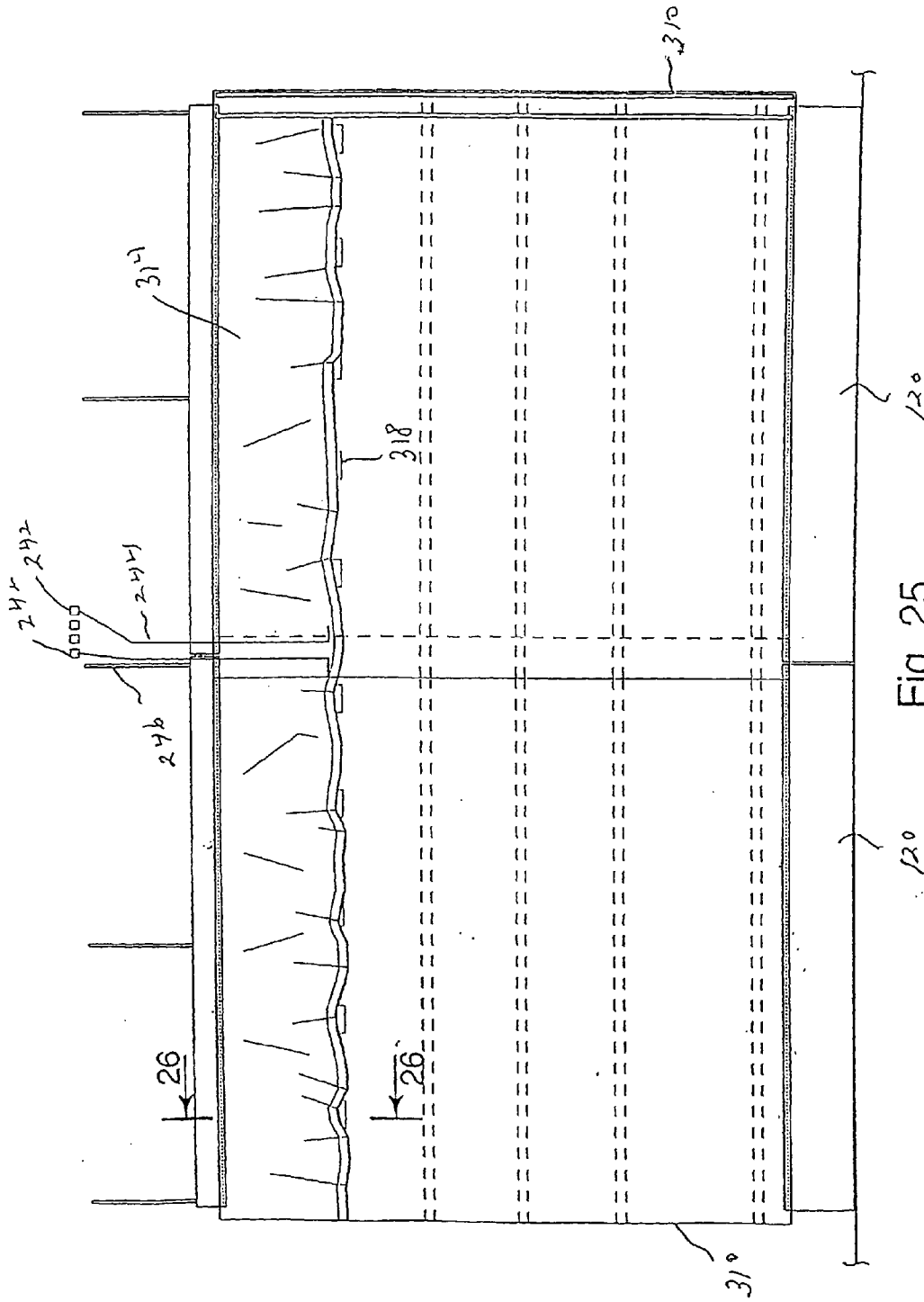

Fig. 25

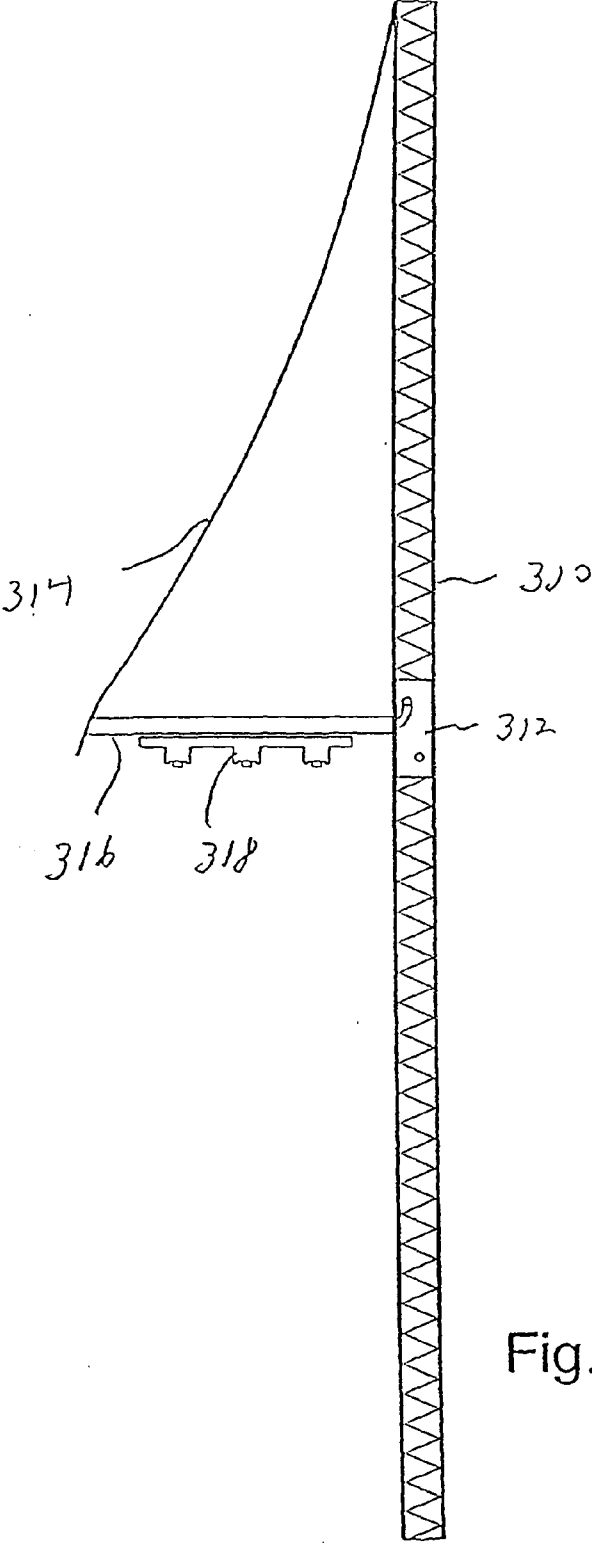

Fig. 26

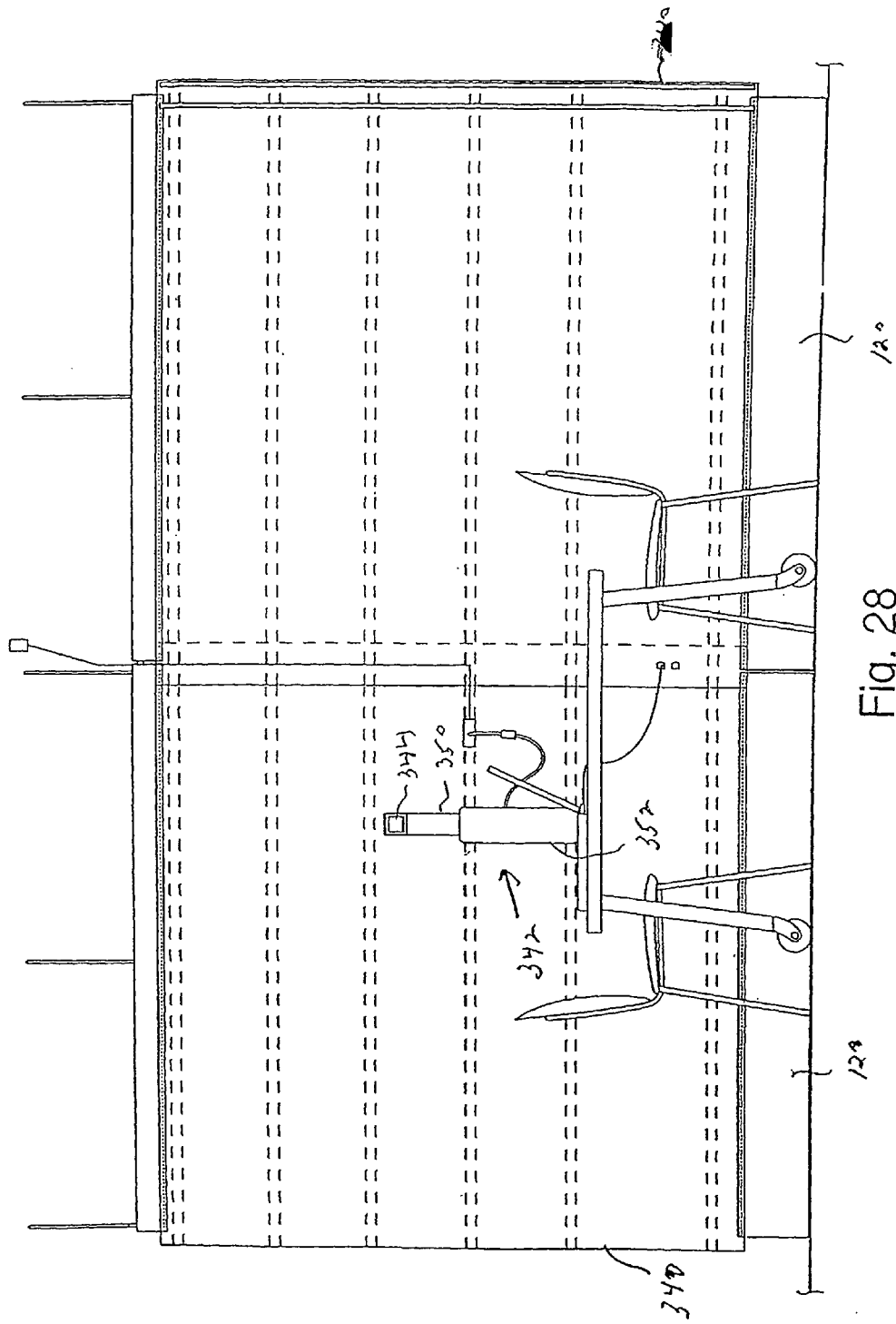

Fig. 28

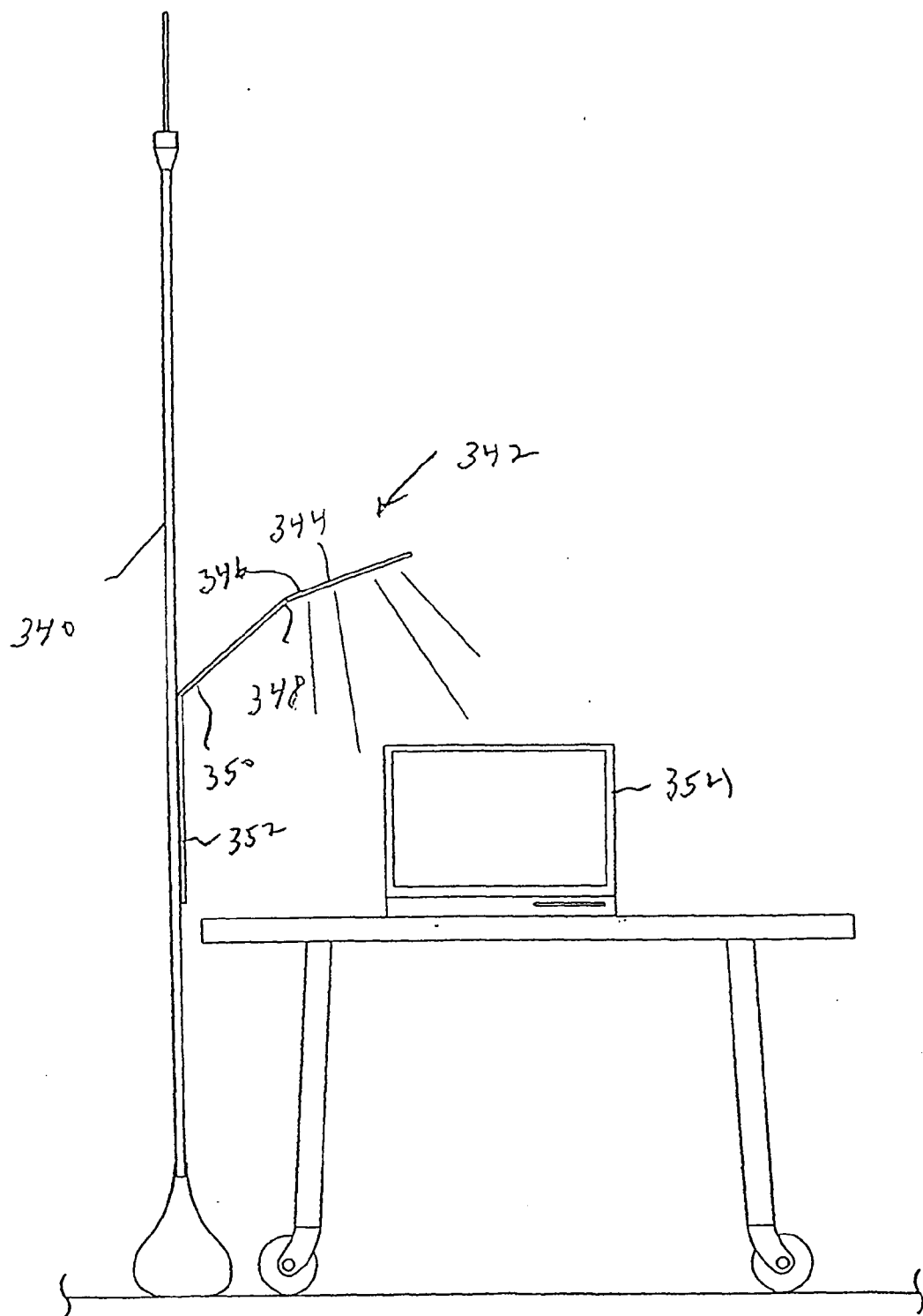

Fig. 29

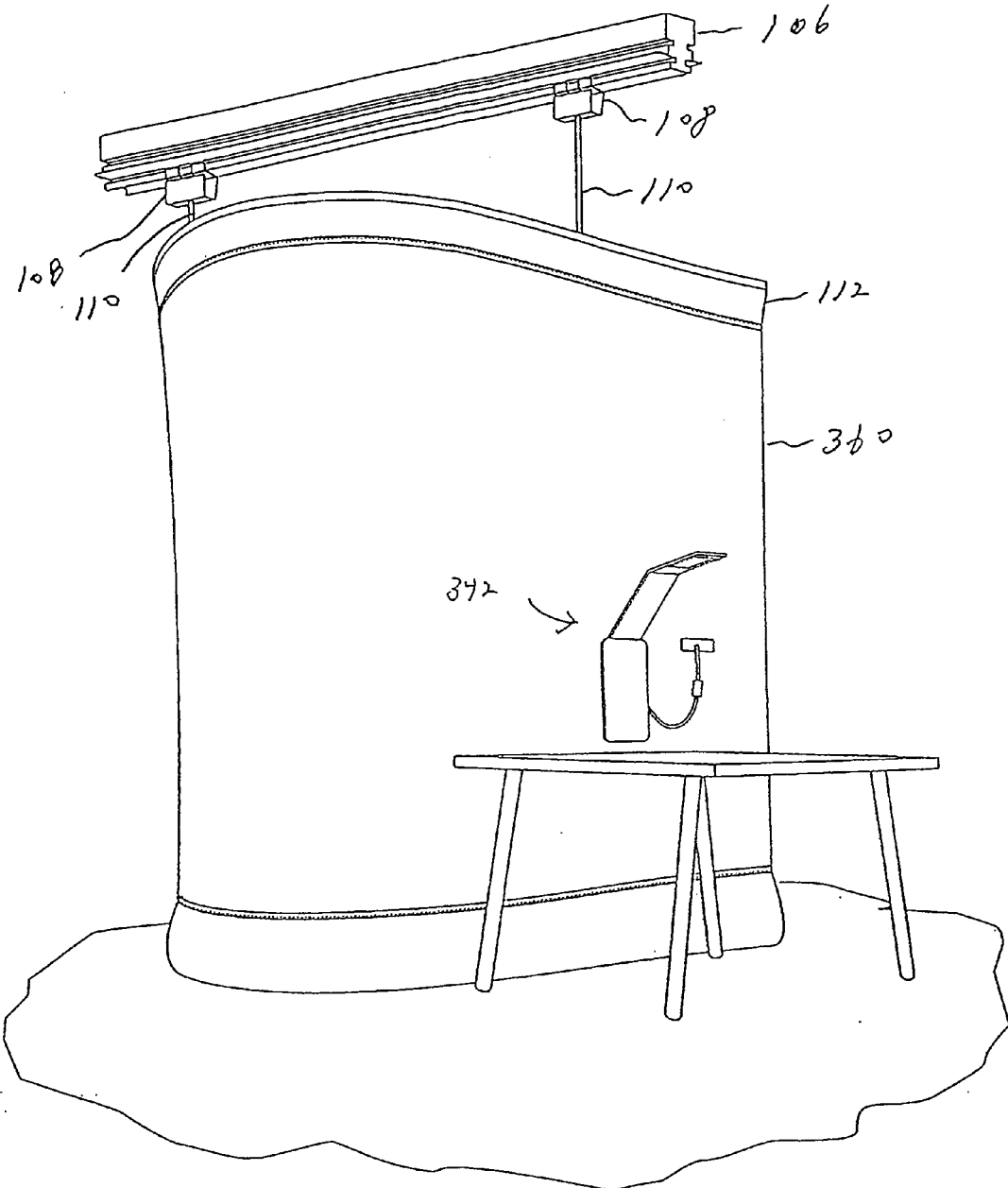

Fig. 30

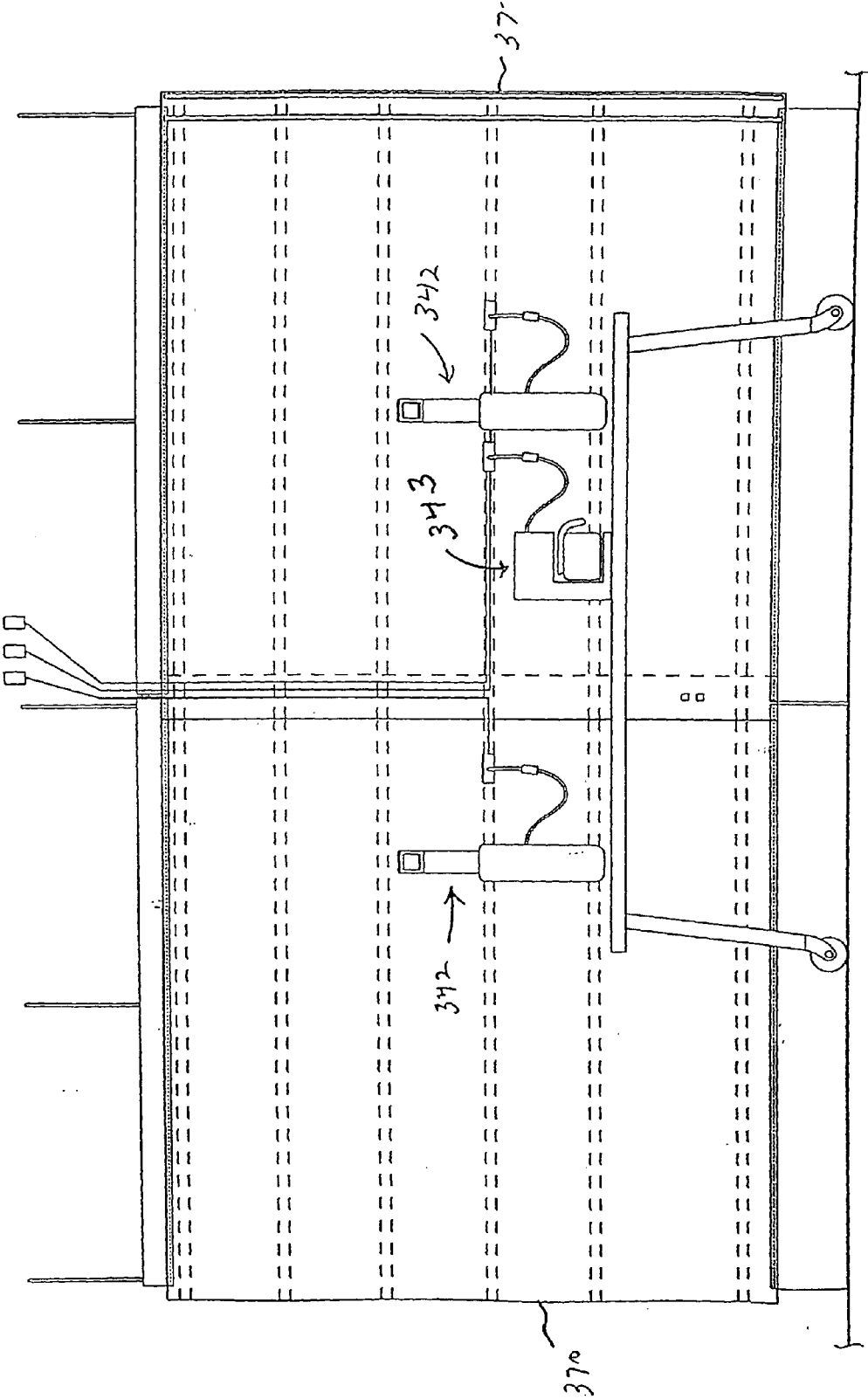

Fig. 31

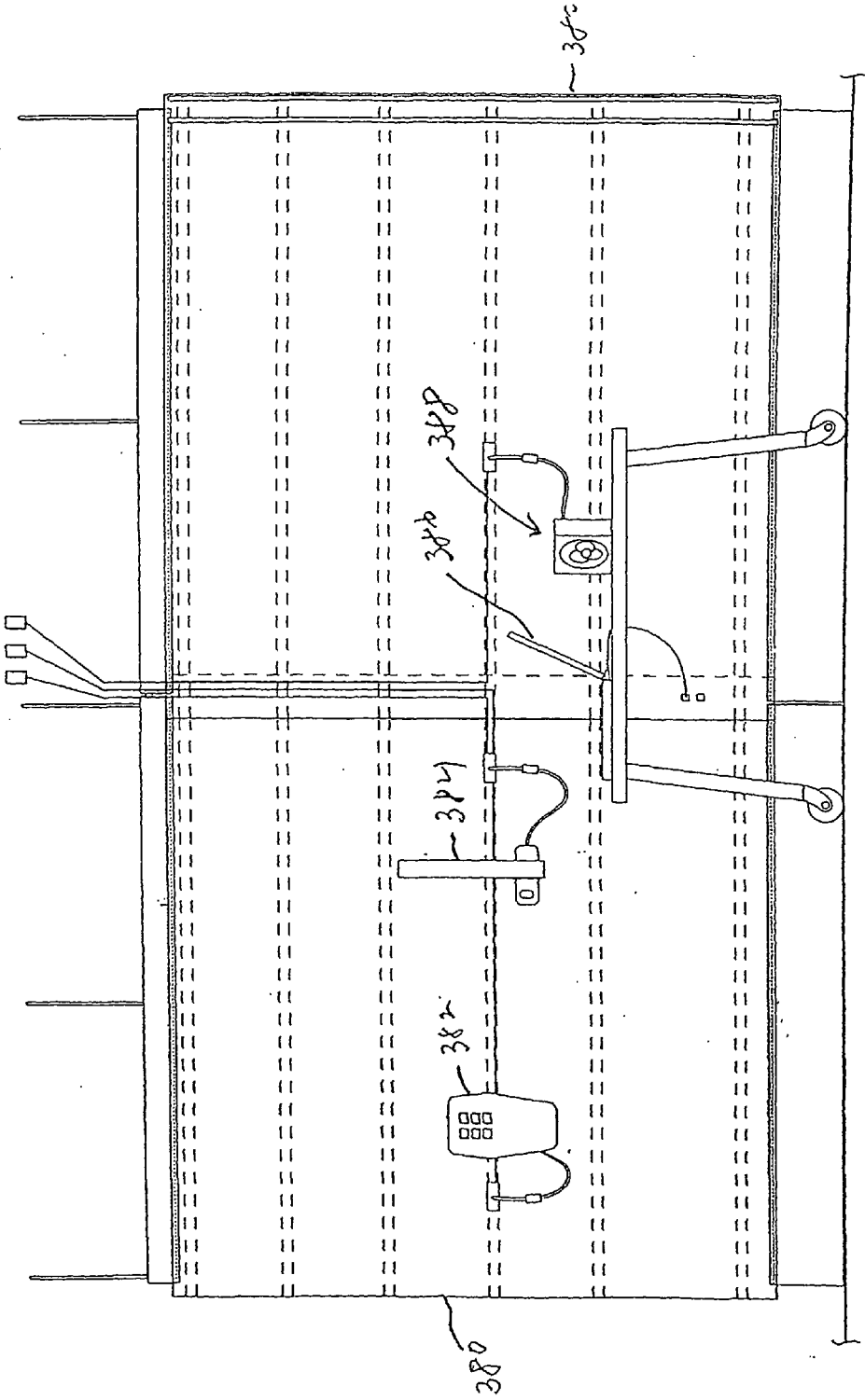

Fig. 32

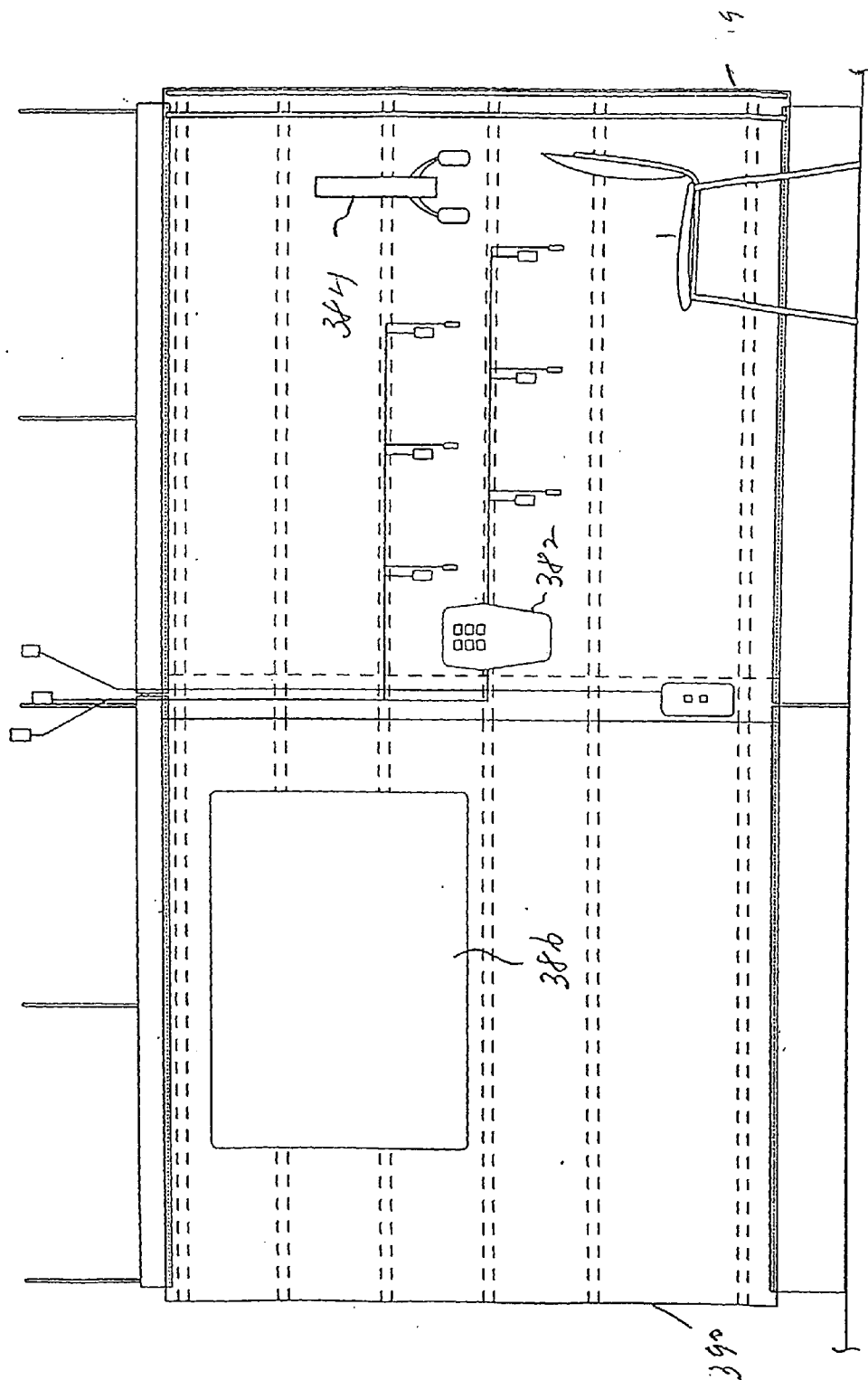

Fig. 33

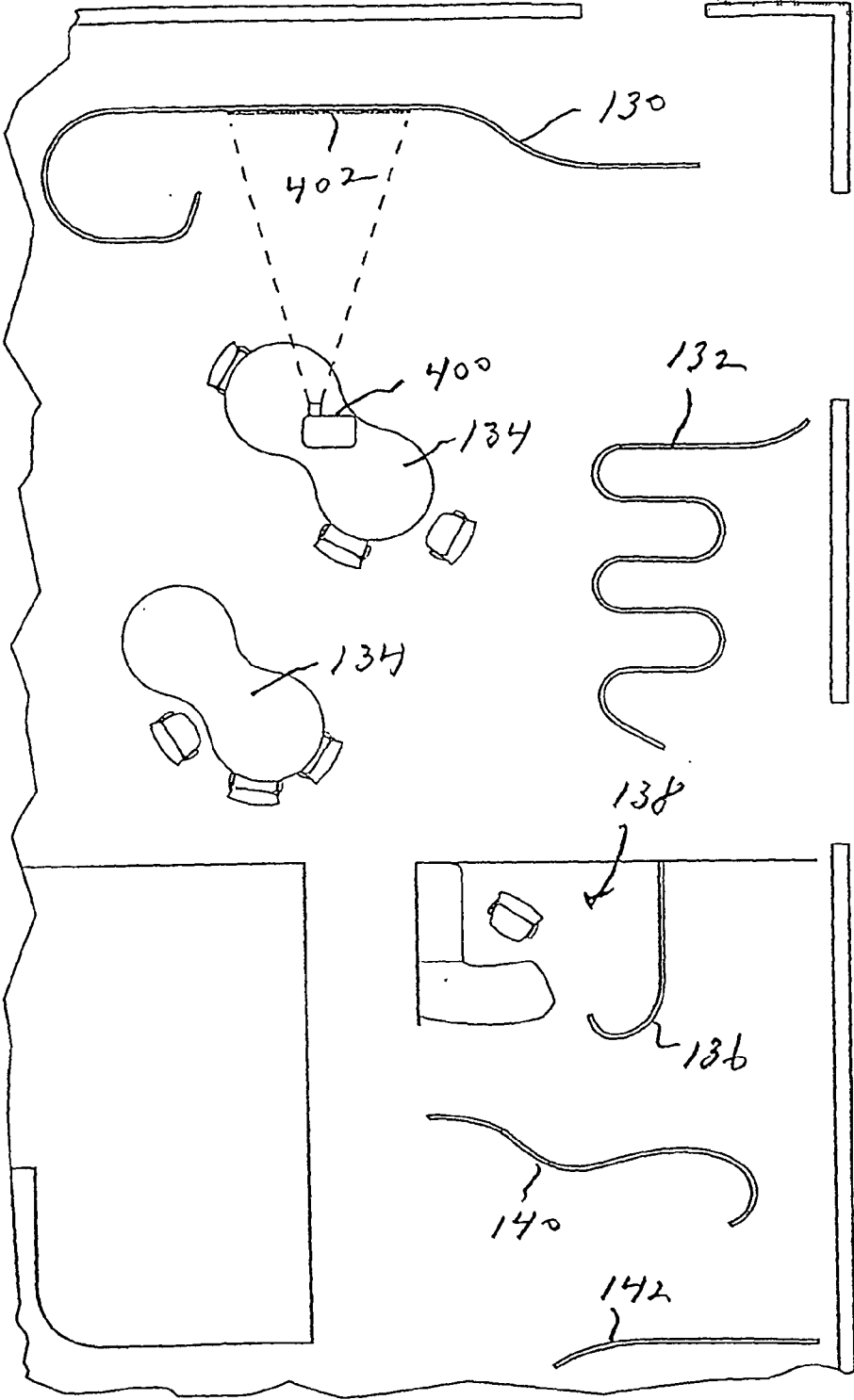

Fig. 34

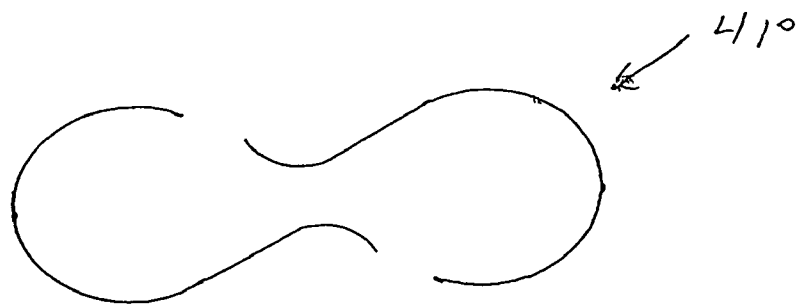

Fig. 35

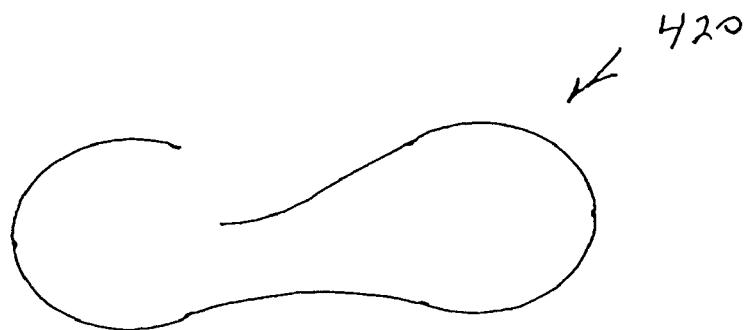
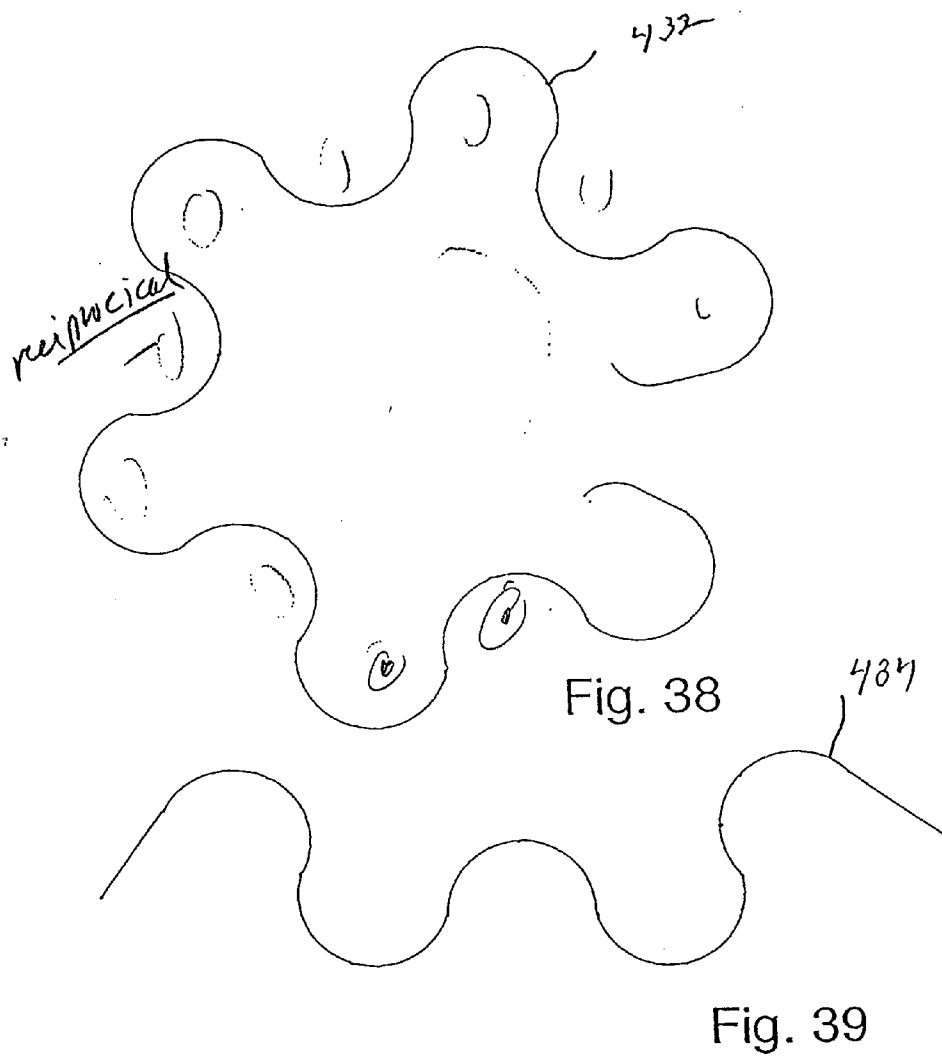
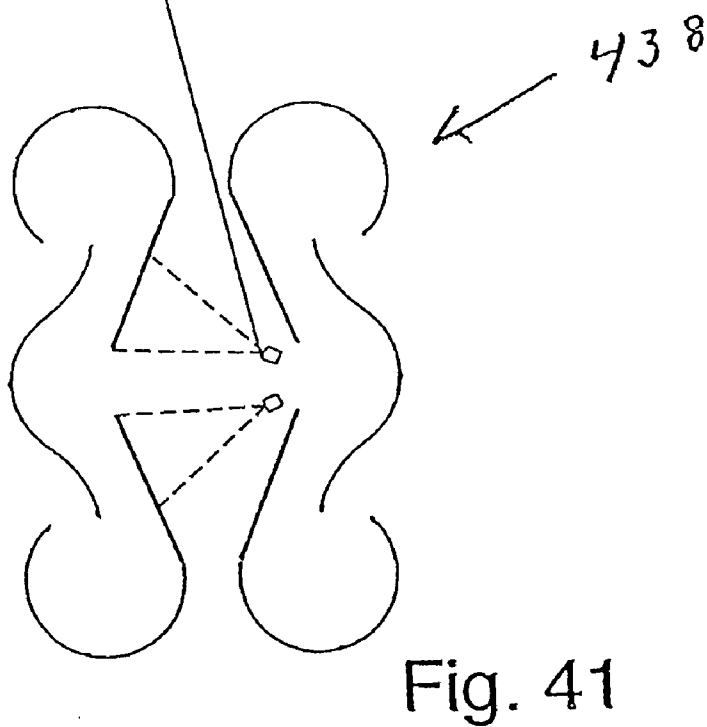
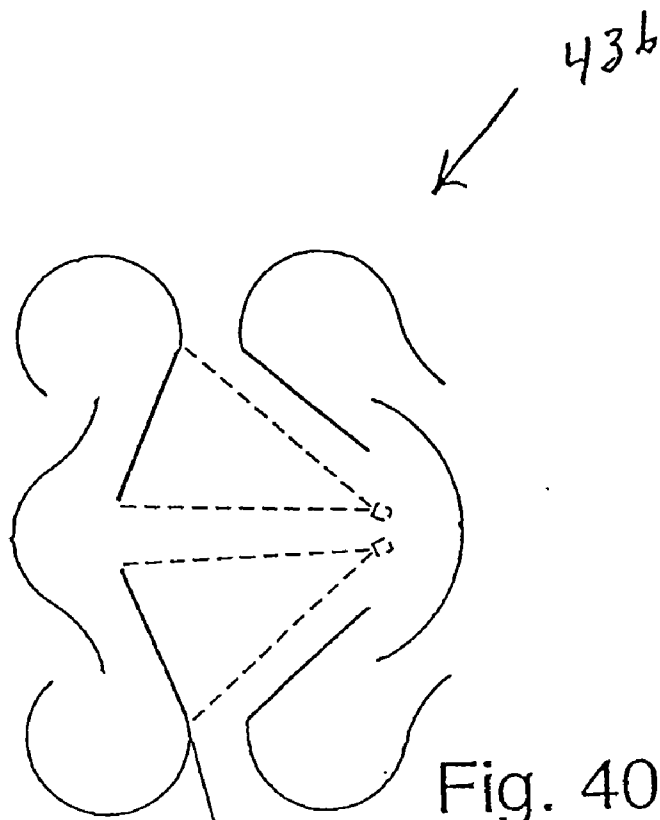

Fig. 36



Fig. 37





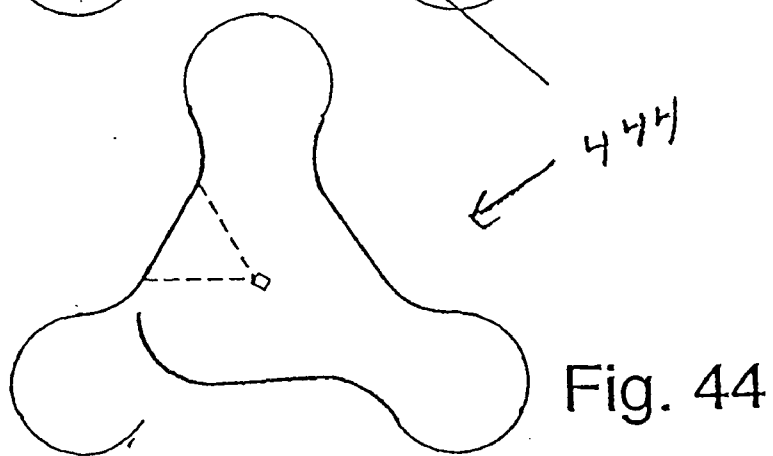
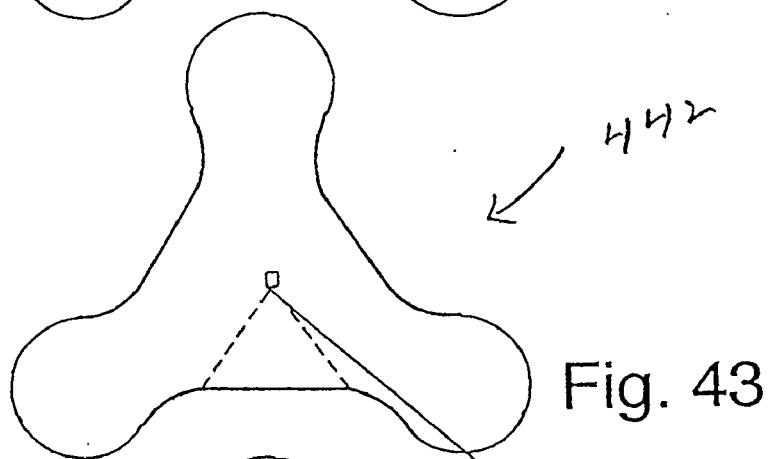
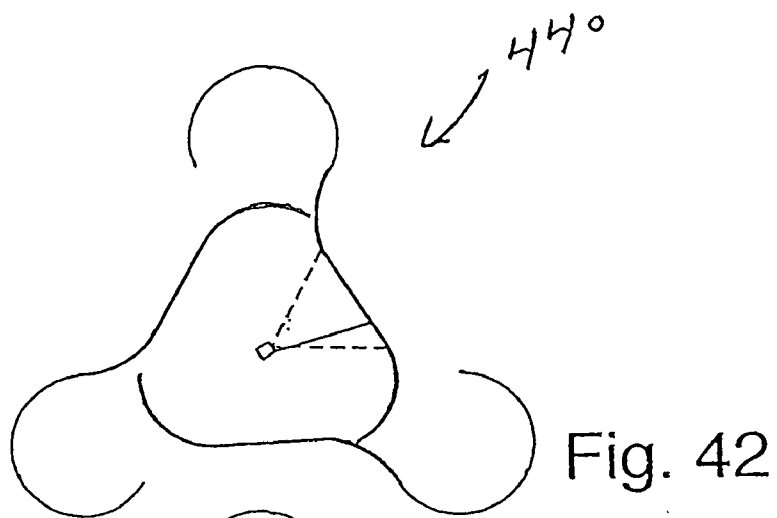

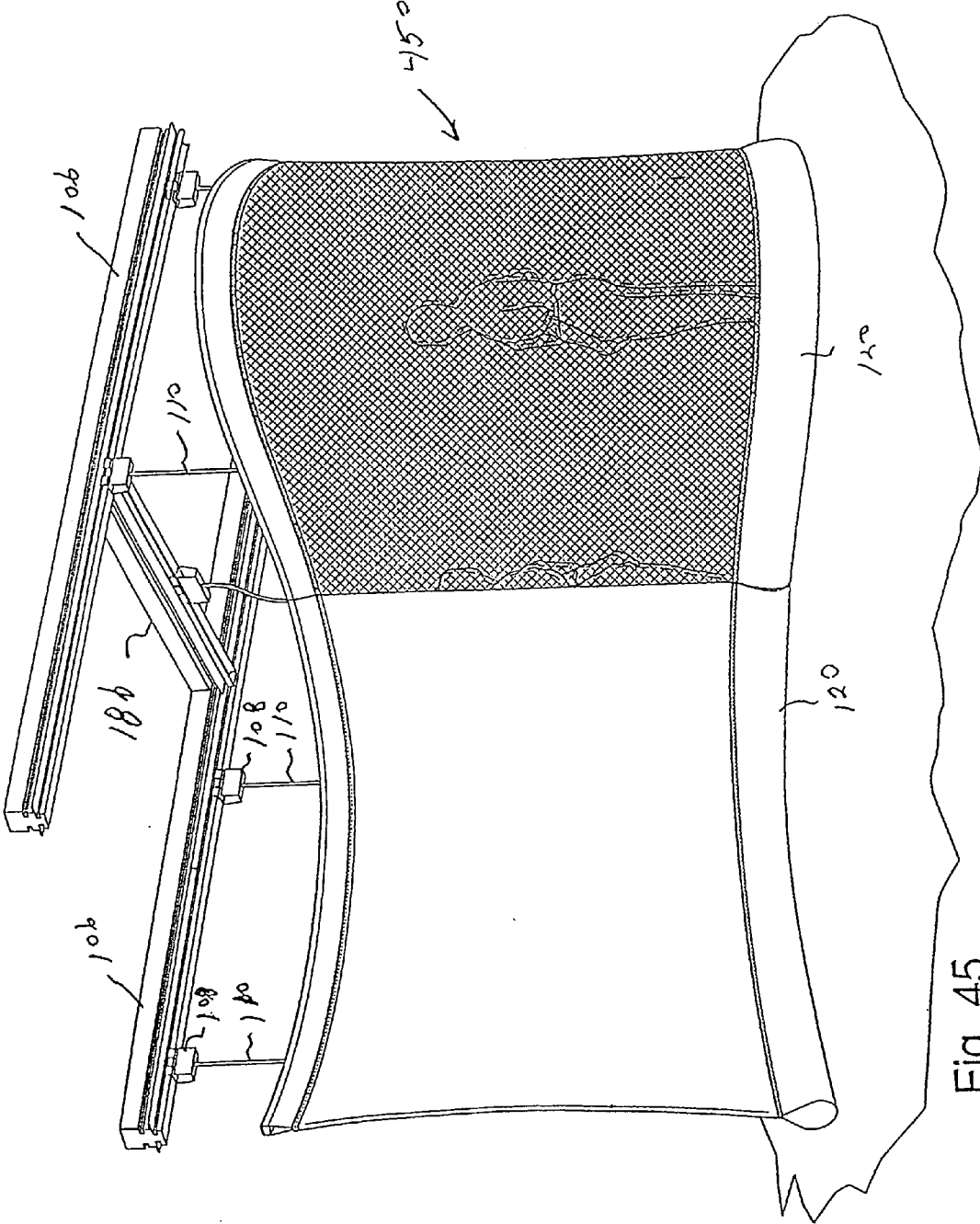

Fig. 45

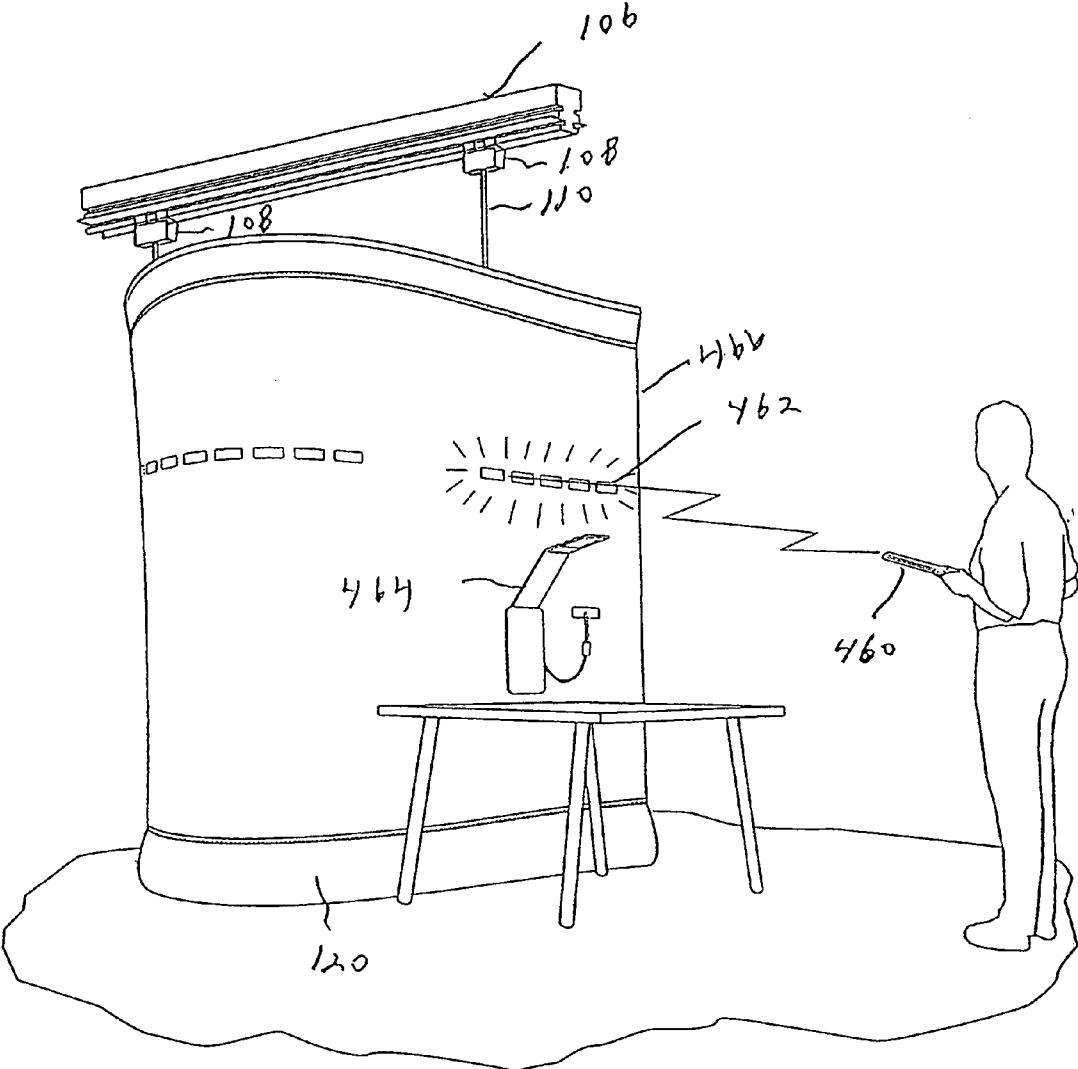

Fig. 46

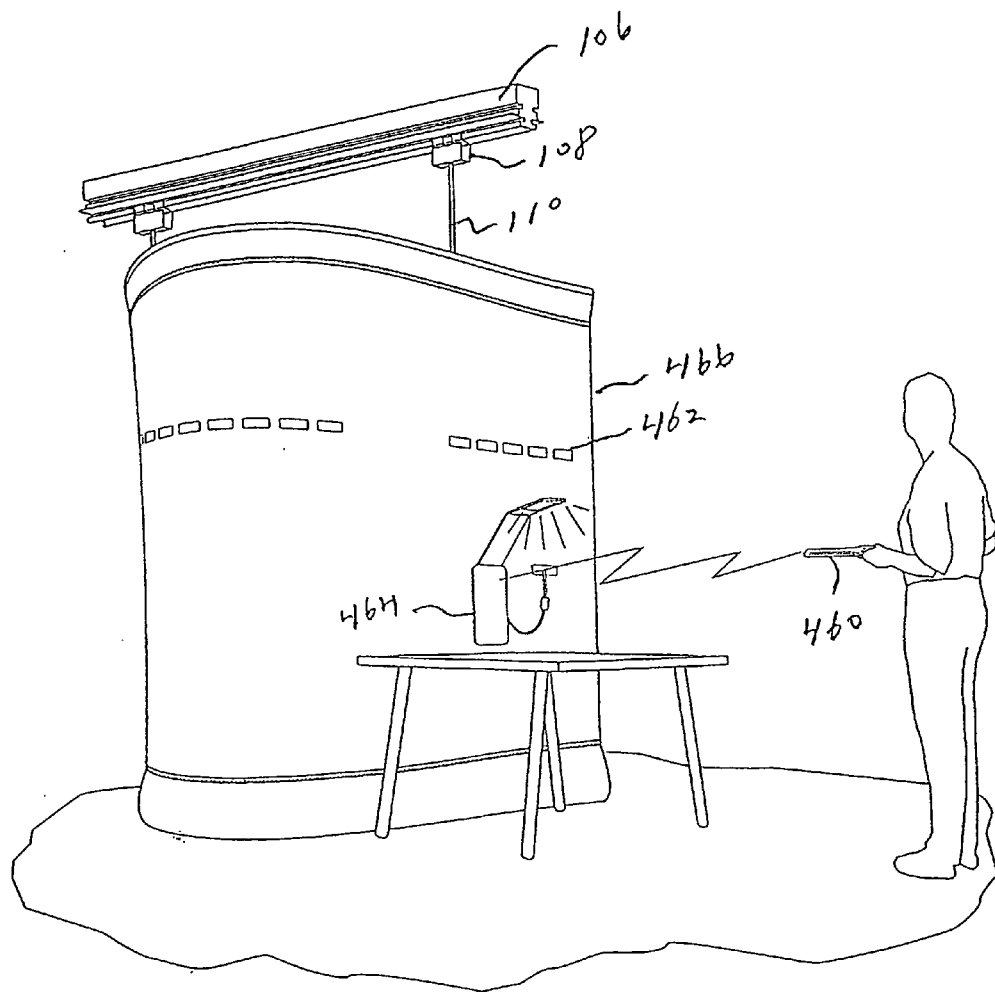
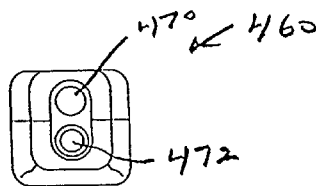
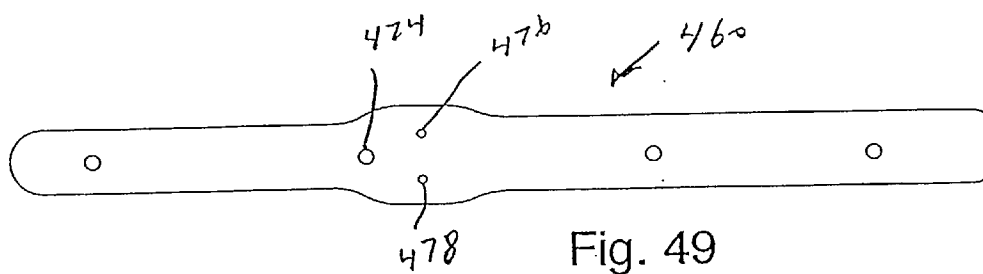
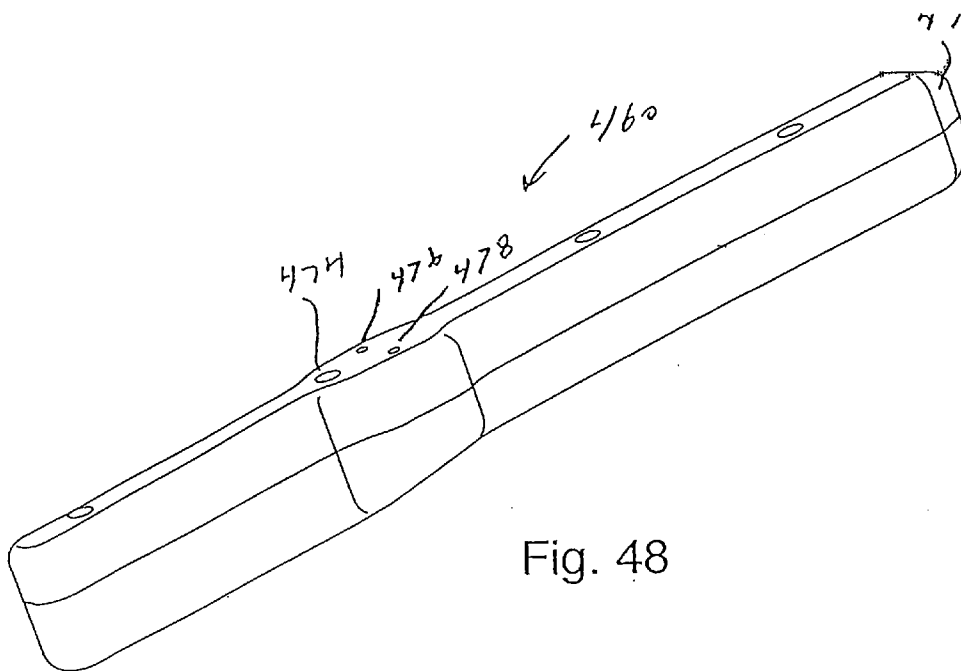

Fig. 47



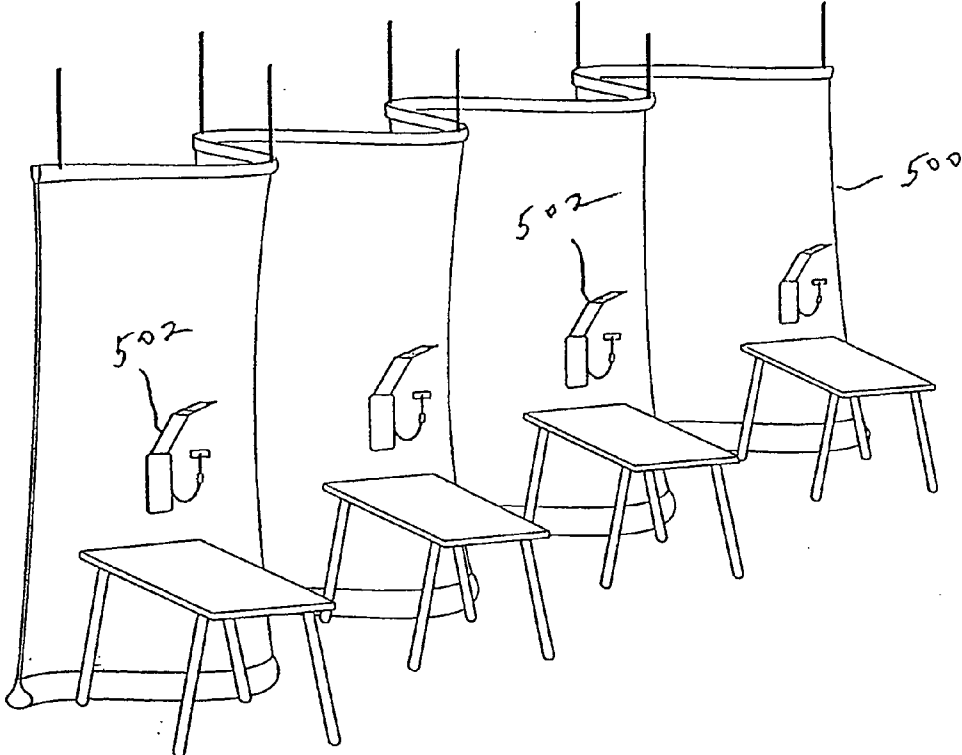

Fig. 51

SPACE DIVISION SYSTEM WITH TECHNOLOGY

CROSS-REFERENCE TO RELATED APPLICATIONS

[0001] This international application is based upon and claims priority of U.S. Provisional Patent Application Ser. No. 60/408,011 filed Sep. 4, 2002.

STATEMENT REGARDING FEDERALLY SPONSORED RESEARCH OR DEVELOPMENT

[0002] Not applicable.

REFERENCE TO A MICROFISHE APPENDIX

[0003] Not applicable.

BACKGROUND OF THE INVENTION

[0004] 1. Field of the Invention

[0005] The invention relates to systems for providing vertically disposed space division and, more particularly, to a flexible system which employs lightweight and rapidly reconfigurable elements with internal stretch characteristics, and with means for providing power distribution, interconnection to and integration of functional components, data storage and control of components through digital programming.

[0006] 2. Background Art

[0007] Building infrastructure, architectural interiors and space division continue to evolve in today's commercial, industrial, office and residential environments. For purposes of the description in this specification, the term "architectural interiors" shall be used to collectively designate the same. Historically, and particularly beginning with the industrial revolution, architectural interiors in the form of space division often consisted of large rooms with fixed walls, ceilings and doors. "Partitions" were only in the form of load-bearing and stationary walls. Interiors would often include large and heavy desks, worktables, machinery, assembly lines or the like, depending upon the particular environment. Lighting, heating and cooling (if any) functions were often centrally controlled. With the exception of executive offices, privacy for face-to-face or telephone conversations, meetings or other activities was difficult to achieve. To accomplish such privacy required additional fixed and costly room architecture. Of course, until the past several decades, and with the exception of telephones and typewriters, there was no need to configure architectural interiors or furniture to facilitate usage of other office equipment, such as computers, copying and facsimile machines. In general, occupants of such architectural interiors had no significant control over their individual environments. This was not only true with respect to locations of partitions or space dividers, but also with respect to lighting, heating and the like. Any reconfiguration of an architectural interior was a significant undertaking.

[0008] During the middle of the Twentieth century, architectural interiors began to see somewhat of a more "sophisticated" approach to flexibility. In part, this was caused by equipment automation, with the advent of electronic copy machines, teletypes, electric typewriters and the like. The architectural interiors needed to take into account greater needs for electrical power and configurations for supplying

power to appropriate locations. Also, "shared" equipment, such as copy machines and teletypes, required consideration of centralized locations (and "common space") and high voltage power supplies. Such automated equipment, and the physical locations of the same, required configurations for supplying power to interior sites. Accordingly, additional development work was performed regarding moving power from exterior supplies into locations other than merely along outer load-bearing walls. Although building owners and tenants began to concern themselves with the foregoing, architectural interiors still typically involved very heavy and relatively "stationary" furniture.

[0009] With respect to space division, additional work was performed regarding physical space dividers. For example, work was undertaken with respect to forming space dividers or partitions in the form of stud walls, steel frames and the like. However, such space dividers still were typically relatively fixed with respect to physical locations, heavy, costly and difficult to move.

[0010] Also during this time, thought was being given to environmental concerns in architectural interiors, such as appropriate air ventilation and the like. New developments occurred in design of ductwork and the like, for bringing HVAC equipment and functions into interior sites. However, such HVAC equipment, as well as lighting and other environmental characteristics, continued to be controlled through central and often remote locations.

[0011] A further advance in architectural interiors began in the 1960's. Several furniture makers began work on office furniture systems having partitions or space dividers which provided at least a minimum level of individual privacy, and defined an individual's "workspace." Some of these space dividers were designed to provide electrical power (interconnected to the building's common power supplies) located at an occupant's workspace. Hanging and supporting bracket structures were developed to provide means for interconnecting furniture accessories (such as shelving, cabinets and work surfaces) to stationary walls or to the space dividers themselves. As these systems evolved, they included arrangements for use with specific utilitarian elements, such as computer stands, keyboard drawers and the like.

[0012] In general, these types of systems as developed over the past several decades can be somewhat characterized as permitting "partial" rearrangement of architectural interiors, and somewhat of an advancement in organizing interior space. Although the term "modular" is sometimes used to describe these types of systems, they did not fit within the true definition of a modular system. Instead, these systems are inherently "closed systems," and are limited to finite sets of interchangeable physical parts.

[0013] With respect to all of the known space division systems, each suffers from a number of various disadvantages. For example, many of the architectural interiors in existence today actually result in an "overperformance." That is, they have weight, bulk and other size parameters which are clearly unnecessary for their desired functionality. Their cost is significant. This cost occurs not only from initial acquisition prices, but also, as a result of their lack of true flexibility, from costs associated with moving or reconfiguring the interiors. Also, in part, additional costs result from the fact that reconfiguration of such systems often

results in wastes of component parts. In this same regard, many component parts of known systems are not reusable when disassembled.

[0014] Still further, known space division systems for many reasons (including those previously stated herein), do not lend themselves to any type of "rapid" reconfiguration. In fact, they may require a significant amount of work to reconfigure. This work often requires use of trained specialists. Also, reconfiguration of known space division systems may involve additional physical wiring or substantial rewiring. Different trained specialists may be required when the reconfiguration in any manner involves such electrical or data/communications components. Still further, although these systems may involve lighting controllable by a workspace user, many environmental functions remain centrally controlled, often in locations substantially remote from the architectural interior being controlled.

[0015] Other disadvantages also exist with respect to these known systems. For example, space dividers in use today are often "ground-based," meaning that they are supported and extend upwardly from floor structures. Many of these configurations are limited in height, and do not particularly lend themselves to visual privacy. Also, as a result of the lack of flexibility and inherent problems with reconfiguration, known systems do not facilitate reconfiguration of space divider groupings, for purposes of individual privacy, collaboration and other "interaction" characteristics.

[0016] As earlier mentioned, known space division systems still do not particularly assist in providing an occupant's control of his or her own environmental conditions. Even further, however, difficulties can arise in known space division systems when environmental characteristic control is provided within a general space of an occupant. For example, lighting associated with an occupant's usage area may be controlled by a switch which is initially relatively close in proximity and readily accessible. However, if this interior space is reconfigured in any substantial manner, the switch controlling the lighting may no longer be accessible or otherwise located in a functionally "correct" position. In this regard, known systems have no capability of providing any relatively rapid reconfiguration of controlling/controlled relationships among functional elements, such as switches, task lights, data terminals and the like. Also, to the extent these relationships are reconfigured, substantial rewiring by personnel having significant technical expertise will be required.

[0017] Another significant disadvantage with known space divider systems relates to their lack of development in light of advances in technology. However, many of these technological advances have modified today's business, educational and personal work practices. Two examples of relatively recent technological advances consist of the semiconductor revolution and the corresponding miniaturization of numerous electrical and data/communications components. Today, the work practices of many individuals involve the use of laptop computers and other portable, electronic devices. Many of these devices have the capability of operating on DC power. However, most of today's space division systems do not provide for availability of such power. In addition, known systems do not provide any other features which will facilitate efficiency in today's new work practices, such as ready access to data storage and the like.

[0018] The foregoing is only a brief description of some of the disadvantages associated with current development in architectural interiors and space division systems. In part, disadvantages exist because of today's business practices. The following paragraphs briefly describe other aspects of today's activities in the areas of architecture and design, and why the foregoing disadvantages of known systems are becoming even more important.

[0019] In the past, problems associated with difficulty in reconfiguration of architectural interiors, and lack of in situ control of a location's environmental conditions, may not have been of primary concern. However, today's business climate often involves relatively "fast changing" architectural interior needs. Architectural interiors may be structurally designed by designers, architects and engineers, and initially laid out in a desired format with respect to lighting fixtures, switches, data lines, and other functional accessories. However, when these structures, which can be characterized as somewhat "permanent" in most buildings (as described in previous paragraphs herein), are designed, the actual occupants may not move into the building for several years. Designers need to "anticipate" the needs of future occupants of the building being designed. Needless to say, in situations where the building will not be commissioned for several years after the design phase, the architectural interior of the building may not be appropriately laid out for the actual occupants. That is, the prospective tenants' needs may be substantially different from the designers' anticipated ideas and concepts. However, as previously described herein, most architectural interiors permit little reconfiguration after completion of the initial design. Reconfiguring of structures in accordance with the needs of a particular tenant can be extremely expensive and time consuming. During structural modifications, the architectural interior is essentially "down" and provides no positive cash flow to the buildings' owners.

[0020] It would be advantageous to always have the occupants' activities and needs "drive" the structure and function of the architectural interior layout. To date, however, many relatively "stationary" (in function and structure) interiors essentially operate in reverse. That is, it is not uncommon for prospective tenants to evaluate a building's architectural interiors and determine how to "fit" their needs (workspaces, conference rooms, lighting, heating, ventilation and air conditioning ("HVAC") requirements and the like) into the existing architectural interiors.

[0021] Still further, and again in today's business climate, a prospective occupant may have had an opportunity to be involved in the design of a building's architectural interior, so that the interior is advantageously "set up" for the occupant. However, many business organizations today experience relatively rapid changes in growth, both positively and negatively. When these changes occur, again it may be difficult to appropriately modify the architectural interior so as to permit the occupant to expand beyond its original architectural interior or, alternatively, be reduced in size such that unused space can be occupied by another tenant.

[0022] The foregoing paragraphs describe reconfiguration as a result of delay time between original design and the time when users actually occupy space, as well as situations where reconfiguration is required as a result of a business

organization's growth or other "external" conditions requiring reconfiguration. In addition, it would also be advantageous to reconfigure architectural interiors substantially on a "real time" basis, where the needs of the occupants change almost instantaneously. That is, the time period required for reconfiguration need not be of any substantial length of otherwise involve changes in a business climate for a particular occupant.

[0023] As an example, it may be advantageous for the occupant of a particular architectural interior to have a specific layout during morning and evening hours, while having a revised layout during mid-day hours. This could occur, for example, in an educational learning center, where usage of the architectural interior by students may change, for example, from primarily "individual" usage in the morning and evening hours, to joint projects and meeting activities requiring collaborative usage during mid-day hours. For such usage, it may be particularly advantageous to have the capability of rapidly modifying interconnections of individual space dividers, providing projection services, and facilitating relocation of laptops, task lighting and the like.

[0024] Other problems also exist with respect to the layout and organization of today's architectural interiors. For example, and as earlier described herein, accessories such as switches and lights may be relatively "set" with regard to locations and particular controlling relationships between such switches and lights. That is, one or more particular switches may control one or more particular lights. To modify these control relationships in most architectural interiors requires significant efforts. In this regard, a architectural interior can be characterized as being "delivered" to original occupants in a particular "initial state." This initial state is defined by not only the physical locations of functional accessories, but also the control relationships among switches, lights and the like. It would be advantageous to provide means for essentially "changing" the relationships in a relatively rapid manner, without requiring physical rewiring or similar activities. In addition, it would also be advantageous to have the capability of modifying physical locations of various functional accessories, without requiring additional electrical wiring, substantial assembly or disassembly of component parts, or the like. Still further, it would be advantageous if users of a particular area could effect control relationships among functional accessories and other utilitarian elements at the location of the architectural interior itself.

[0025] Various types of space division systems are known in the prior art. For example, Roberts, U.S. Pat. No. 5,274, 970 issued Jan. 4, 1994, discloses a freestanding space division system having upstanding posts for resting on the floor. At least one rail assembly is extended between adjacent posts and spaced from the floor. Saddles hang from the rail assembly, and trays are suspended from the saddles so as to form raceways. Vertical pole assemblies are detachably mounted to each post and extend "axially" so that a pair of adjacent pole assemblies on a rail can define a panel receiving space.

[0026] Goodman, et al, U.S. Pat. No. 6,047,508 issued Apr. 11, 2000, discloses a wall panel space division system having a movable panel with a rigid frame. A core panel is mounted in the frame, and at least one cover panel is detachably mounted on the frame and encloses an associated

portion. The frame has at least one vertical stile with first and second channels that extend longitudinally therealong. The stiles are shaped to receive utilities through outwardly opening sides. The outwardly opening sides of the panels are juxtaposed in opposing directions, so as to facilitate routing utilities along both faces of the panel. A variable height frame support may be positioned between the top of the panel and the building ceiling for floor-to-ceiling applications.

SUMMARY OF THE INVENTION

[0027] In accordance with the invention, a space division system is adapted for use with a supporting infrastructure. The supporting infrastructure provides for distribution of electrical and communication signals. Specifically, the space division system includes a number vertically disclosed partitions. Support means are coupled to the supporting infrastructure and to the partitions for movably supporting the partitions from the supporting infrastructure. Means are also provided for relocating the partitions at selected locations relative to the infrastructures. Means are also provided for effecting a plurality of spatial configurations among the partitions.

[0028] The plurality of configurations may include a plurality of the partitions having a curvilinear structure. The supporting means may be adjustable in a manner so that a height of at least a subset of the plurality of partitions may be adjustable. At least one of the plurality of partitions may comprise an upper structural batten. A main body extends downwardly from the structural batten, and the main body is constructed of a fabric which is substantially opaque. The partitions include at least one space divider having a lower hemmed section with a weighted insert. The partitions can also include at least one space divider having a hook configuration. Still further, the partitions can include at least one space divider having a configuration with a series of S-shaped curvatures. The S-shaped curvatures form partially enclosed workstations.

[0029] The partitions can also include at least one space divider consisting of a translucent and stretchable material. The partitions may also include at least one space divider consisting of a pre-woven material. The pre-woven material may consist of a cattle mattress material.

[0030] At least one of the space dividers may have a weighted insert consisting of a tubular section fitted within a lower hem of at least one partition. The tubular section may be filled with sand. The tubular section may also be a flexible sheath consisting of rubber. The weighted insert can include an end cap interconnected to a cooperating means of another weighted insert associated with an adjacent space divider.

[0031] Adjacent ones of the partitions may be releasably coupled together through a quick release and quick connect mechanism. The mechanism may include spring clips.

[0032] At least one of the partitions may include a space divider consisting of three-dimensional translucent material. In accordance with another aspect of the invention, a space divider may be structured in a flutter form configuration. Still further, at least one of the partitions may include a space divider having a quad-pole configuration. Still further, at least one of the partitions may include a space divider having a tri-pole configuration.

[0033] In accordance with another aspect of the invention, the space division system may include electrical and communication connection means associated with at least a subset of the partitions. In this manner, electrical and communication signals may be transmitted and/or received from the supporting infrastructure. Accordingly, electrical and communication signals may be applied to functional accessories releasably coupled to the subset of the partitions.

[0034] The subset of the partitions may include main bodies having lighting means embedded within the main bodies, in a manner so as to be visible to a person substantially adjacent the space dividers. The lighting means may include solid state lighting technology. More specifically, the solid state lighting technology may include a plurality of LED lights. Still further, the solid state lighting technology may include arrow lighting positioned adjacent a lower portion of the main bodies. The space division system may also include means for simultaneously activating all arrow lights of the arrow lighting or, alternatively, activating the arrow lights in a manner so that the lights are sequentially pulsed, so as to create an effective "pointing" in a particular direction.

[0035] The connection means may include means for interconnecting telephone apparatus to communication signaling of the supporting infrastructure. The subset of the partitions may comprise space dividers having power battens positioned at a top portion thereof, for purposes of carrying power. The power may include both low voltage DC and AC power.

[0036] With respect to the battens, the power battens may have openings accessible to internal linear voids existing within knitting of the main bodies. Power cables may be extended within the voids. A subset of the partitions may include space dividers consisting of structural battens at the top ends thereof. Fabric may extend downwardly therefrom, and linear voids may be formed within the fabric, at spaced apart intervals downwardly along the space dividers. In addition, the subset of the partitions may include space dividers having power battens extending downwardly so as to form end hems of the sections. Low voltage DC power strips and/or communication cables may extend through the power battens. The power battens may be formed by taking sections of the space dividers and turning them rearward upon themselves. Ends of the space dividers may then be connected to other portions of the space dividers through the use of releasable securing means.

[0037] The subset of the partitions may include space dividers formed of translucent material, with communication cables extending through pre-woven pockets of the translucent space dividers. The subset of the partitions may include space dividers having a plurality of internal linear voids. Linear LED lighting strips may be inserted through the voids. The internal linear voids may be horizontally located within the space dividers, and further carry power cables and communication cables.

[0038] The LED lighting strips may comprise linear flex side lighting strips. Correspondingly, the space dividers may include global communications interconnections. Still further, the space dividers may include a second set of LED lighting strips turned in a different direction from the original LED lighting strips. In this regard, actual light intensity and light diffusion at opposing surfaces of the space dividers

may differ depending upon the particular sections. The linear voids may carry LED lighting strips having a substantially flat configuration. The LED lighting strips may have particular light intensity and light dispersion as viewed on one surface of the space divider, while a relatively opaque view is produced on an opposing surface of the space divider. The subset of the partitions may also include space dividers having LED lighting technology employed externally of the space dividers.

[0039] The space dividers may include curtains mounted from top portions of the sections. LED lighting strip supports may depend forwardly and horizontally or angularly from the space dividers, and appropriately secured to linear voids of the space dividers. Positioned downwardly from the supports is a series of LED lights. The LED lights have appropriate colors so as to provide an external color wash over a lower portion of the side surfaces of the space dividers, below the curtain. The color wash can be modified in intensity and with respect to diffusion, dependent upon intensity and color of the LED lights, and also dependent upon the particular materials from which the space dividers are constructed.

[0040] The subset of the partitions may include space dividers having low voltage DC power lines, communications cabling, AC power and AC power lines. At least one of the AC power lines terminates in a pair of electrical receptacles. Conventional electrical appliances may be energized through the electrical receptacles. An AC power line may also be utilized, through the electrical receptacles, to energize computerized apparatus.

[0041] Data on communications signals may be transmitted from the computerized apparatus through a communications signal junction box. From the junction box, signals may be transmitted outwardly through the communications cabling.

[0042] The space dividers may include electrical connections of at least one task light to the electrical signals of the supporting infrastructure. The task light may include a rectangular LED marker at a terminus of the light. A flexible joint may be employed, and a fabric cover may be extended downwardly and angularly from the flexible joint. The fabric cover may be interconnected to a securing bracket which, in turn, is secured to at least one of the space dividers.

[0043] The space dividers may also include projection screens releasably secured thereto. In addition, the space division system may include utilitarian elements associated with the partitions, with the utilitarian elements comprising at least one controlling device. The utilitarian elements may also include at least one controlled device, with the controlled device having at least first and second states. The communications signals may be utilized to effect a logical control relationship between the controlling device and the controlled device. The logical control relationship may be reconfigured at least in part with the communication signals, in the absence of any physical relocation of any physical wiring associated with the controlling device and the controlled device. The system may include at least one manually operable programming means for transmitting programming signals so as to effect the logical control relationship. The utilitarian elements may be manually releasable from the partitions.

[0044] In accordance with further aspects of the invention, the space division system may comprise audio apparatus

integrated with at least a subset of the partitions. The audio apparatus may include a plurality of speakers energized from the electrical signals. These speakers may comprise controlled devices, and the system may further comprise at least one controlling device. The communication signals may be utilized to effect a logical control relationship between the controlling device and the speakers. In addition, the system may include at least one manually operable programming means as the controlling device, for purposes of transmitting programming signals so as to effect the logical control relationship with the speakers.

[0045] The system may also include sound management apparatus for providing means for controlling perceptions of sound at spatial locations adjacent the space division system. The sound management apparatus can be powered at least in part through the distribution of the electrical signals. Further, the speakers may be utilized to generate noise masking audio signals, for purposes of providing sound management at spatial locations around the space division system.

[0046] In another aspect, the space division system may be adapted for use with an articulating ceiling. Still further, at least a subset of the partitions may be constructed at least in part of materials having substantial capabilities of resisting penetration. The subset of the partitions may be constructed at least in part of materials within the group of Aramids. Still further, the subset of the partitions may be constructed at least in part of Kevlar® brand fiber.

[0047] In accordance with another aspect of the invention, the plurality of partitions can comprise at least a subset of the partitions constructed at least in part of materials consisting of fire-resistant or fire-proof materials. The subset of the partitions may consist at least in part of materials within the group of Aramids. In this regard, the subset of the partitions may consist at least in part of materials consisting of Nomex® brand fiber. In addition, the plurality of partitions can comprise at least a subset of the partitions consisting at least in part of materials comprising a blend of Kevlar® and Nomex® brand fibers.

[0048] In accordance with a further aspect of the invention, the space division system can comprise means for securing at least a subset of the plurality of partitions to a lower floor structure. Further, the space division system can comprise switch means for controlling functional accessories associated with the partitions. The switch means can comprise switches having differing spatial positions for generating “on” and “off” states. The switch means may be electrically responsive to spatial signals so as to change between control states.

[0049] Still further, the switch means can comprise pressure switches. The switch means can be responsive to signals indicative of motion within areas surrounding the switch means, for purposes of switching between control states. The switch means can also be responsive to radio frequency signals for switching between control states. In addition, the switch means can be responsive to infrared signals for switching between control states.

[0050] In accordance with a further aspect of the invention, the at least one controlling device can comprise at least one switch. Also, the system can comprise means for generating and for sensing radio frequency identification signals.

BRIEF DESCRIPTION OF THE SEVERAL VIEWS OF THE DRAWING

[0051] The invention will now be described with reference to the drawings, in which:

[0052] FIG. 1 is an example embodiment of one space divider within a space division system with technology in accordance with the invention, with the space divider hung from a rail system having communications, and with the space divider displaying certain SSL lighting technology;

[0053] FIG. 2 is a plan view of an office environment showing the space division system in accordance with the invention, in various configurations;

[0054] FIG. 3 is a side elevational view of the system, showing the space divider with 3D translucency, and with the use of stretch material;

[0055] FIG. 4 is an end view of the space divider of FIG. 3, showing material characteristics and taken along section lines 4-4 of FIG. 3;

[0056] FIG. 5 illustrates a space divider in accordance with the invention, utilizing what is characterized as “cattle mattress” material, with FIG. 5 being a side elevational view;

[0057] FIG. 6 is a sectional end view, taken along section lines 6-6 of FIG. 5, for purposes of showing material characteristics;

[0058] FIG. 7 is a perspective view of two curved space dividers of the space division system in accordance with the invention;

[0059] FIG. 8 is partial sectional view of the bottom and top detail of the space dividers in FIG. 7, taken along section lines 8-8 of FIG. 7;

[0060] FIG. 8A is an end view of an alternative embodiment for an articulated bottom which may be utilized with the space dividers of FIG. 7;

[0061] FIG. 8B is a perspective view of the alternative embodiment illustrated in FIG. 8A;

[0062] FIG. 9 is an end sectional view of a section of the space dividers shown in FIG. 7, taken along section lines 9-9 of FIG. 7;

[0063] FIG. 10 is a section of the junction between the adjoining space dividers shown in FIG. 7, and taken along section lines 10-10 of FIG. 7;

[0064] FIG. 11 is a “close up” sectional view of an end portion of a wall of the space division system in accordance with the invention, illustrating the use of 3D translucent material, and also showing power/communication cables extending through a pre-woven pocket;

[0065] FIG. 12 is a “close up” sectional view of the junction of the two space dividers in FIG. 7, illustrating the use of 3D translucent material, and also showing power/communication cables extending through the pre-woven portion of the pocket;

[0066] FIG. 13 is a “close up” sectional view of an end portion of the wall shown in FIG. 7, with the space divider

utilizing “cattle mattress” material, and with power/communication cables from the rail system extending through the pre-woven pocket;

[0067] FIG. 14 is a “close up” sectional view of the junction of two space dividers utilizing the “cattle mattress” material, and also showing the power/communication cables extending through the pre-woven pocket;

[0068] FIG. 15 is a side elevational view of one of the space dividers of the space division system in accordance with the invention, illustrating the use of internal LED light technology;

[0069] FIG. 16 is a sectional end view of details of the internal LED light technology of FIG. 15, taken along section lines 16-16 of FIG. 15, and illustrating the concept of utilizing a pattern having a flexibility of location for color wash or signaling, and further illustrating the concept of channel voids being integral to the fabric;

[0070] FIG. 17 is a side elevational view of a partition panel of the space division system in accordance with the invention, illustrating another arrangement for use of internal LED light technology;

[0071] FIG. 18 is a sectional end view of a portion of the space divider shown in FIG. 17, taken along section lines 18-18 of FIG. 17;

[0072] FIG. 19 is a side elevational view of space dividers of the space division system in accordance with the invention, illustrating another configuration of the internal LED light technology utilized with the space dividers;

[0073] FIG. 20 is a sectional end view of a portion of the space divider illustrated in FIG. 19, taken along section lines 20-20 of FIG. 19;

[0074] FIG. 21 is a side elevational view of a space divider of the space division system in accordance with the invention, and illustrating another embodiment of the use of internal LED light technology with the space divider;

[0075] FIG. 22 is a sectional end view showing a portion of the space divider of FIG. 21, taken along section lines 22-22 of FIG. 21;

[0076] FIG. 23 is an alternative sectional end view taken from FIG. 21, and showing the use of the LED light technology in a manner which may be important for emergency directional lighting, and illustrating the use of internal LED lighting on both sides of a space divider;

[0077] FIG. 24 is a side elevation view of a space divider of the space division system in accordance with the invention, and illustrating the use of internal LED technology with arrows;

[0078] FIG. 25 is a side elevational view of a space divider of the space division system in accordance with the invention, and showing the use of external LED light technology, so as to provide a “color wash” along one side of the space divider;

[0079] FIG. 26 is a sectional end view of the space divider illustrated in FIG. 25, and taken along section lines 26-26 of FIG. 25;

[0080] FIG. 27 is a side elevational view of space dividers of the space division system in accordance with the invention, and illustrating the use of the space dividers with power and data storage;

[0081] FIG. 28 is a side elevational view of the use of space dividers of the space division system in accordance with the invention, and further showing the use of SSL task lighting technology with the space dividers;

[0082] FIG. 29 is a front elevational view, illustrating the task lighting technology of FIG. 28;

[0083] FIG. 30 is a perspective view showing a curved space divider, and further showing the use of task lighting technology with the space divider;

[0084] FIG. 31 is a side elevational view of space dividers of the space division system in accordance with the invention, and showing DC low voltage technologies associated with the space dividers;

[0085] FIG. 32 is a side elevation view of space dividers of the space division system in accordance with the invention, illustrating various office environment technologies incorporated with the space dividers, and further illustrating the use of Velcro clips on attachment points;

[0086] FIG. 33 is a side elevational view of space dividers of the space division system in accordance with the invention, showing the space dividers with use of technology in a temporary work or gathering space, where the technology may comprise data storage switches, headphones, projection screens and the like;

[0087] FIG. 34 is a top plan view of a mockup office environment similar to that of FIG. 2, but showing the use of a projector and screen with one of the configurations of the space dividers;

[0088] FIG. 35 is a plan view of one embodiment of a shape of space dividers of the space division system in accordance with the invention;

[0089] FIG. 36 is a plan view of a further embodiment of the use of space dividers of the space division system in accordance with the invention;

[0090] FIG. 37 is a plan view of a still further embodiment of the use of the technology curtains of the space division system in accordance with the invention;

[0091] FIG. 38 is a plan view of a particular configuration of the space dividers characterized as a “flutter” form;

[0092] FIG. 39 is a plan view of a further embodiment of a “flutter” form configuration of the space dividers;

[0093] FIG. 40 is a plan view of a configuration of the space dividers, with the configuration illustrating positions of individual and collective space, and with FIG. 40 specifically illustrating a “quad-place” configuration;

[0094] FIG. 41 is a plan view of a further embodiment of a “quad-place” configuration, with the embodiments of FIGS. 40 and 41 showing individual and collective space, and moving to more collectivity with a less flexible central passageway, where the space grows so as to accommodate group work;

[0095] FIG. 42 is a plan view of space dividers of the space division system in accordance with the invention, in a configuration which illustrates a “triplace” configuration, having three spaces;

[0096] FIG. 43 is a plan view of an alternative embodiment, illustrating a single space configuration;

[0097] FIG. 44 is a plan view of a third alternative embodiment, illustrating a configuration with two spaces;

[0098] FIG. 45 is a perspective view of a translucent partition panel of the space division system in accordance with the invention, in use;

[0099] FIG. 46 is a perspective view of a user employing a control wand for purposes of reconfiguring control relationships among technologies associated with the space division system, with the user working on control relationships associated with activation of LED technologies on the space dividers;

[0100] FIG. 47 illustrates a perspective view of a user employing the control wand for purposes of working on control relationships associated with the task lighting technologies of the space division system;

[0101] FIG. 48 is a perspective view of a control wand which may be utilized in accordance with the invention;

[0102] FIG. 49 is a plan view of the control wand of FIG. 48;

[0103] FIG. 50 is a front elevational view of the control wand of FIG. 48; and

[0104] FIG. 51 is a perspective view of an arrangement of a partition panel of the space division system in accordance with the invention, using task lighting technologies in an arrangement which could be employed for a library, study hall, restaurant or similar environment.

DETAILED DESCRIPTION OF THE INVENTION

[0105] The principles of the invention are disclosed, by way of example, in a space division system 100, incorporating technology. The space division system 100 utilizes a series of movable and internally reconfigurable vertically disposed partitions for purposes of providing lighting aesthetics, function signaling, privacy, semi-private configurations and the like. In addition, the space division system 100 in accordance with the invention also provides a space division system which facilitates incorporation of various technologies. Space dividers and other aspects of the space division system 100 in accordance with the invention are capable of physical relocation, and comprise lightweight components. Rapid addition/deletion of joined space dividers is provided, through the use of quick-release components.

[0106] A number of other advantages also exist with respect to space division systems in accordance with the invention. More specifically, the invention includes the use of spline concepts for joined connection of space dividers. In this manner, formation of various configurations of the space division system 100 have moved from known line segment configurations, to having the capability of a configuration having a curve of any desired radius. In the same regard, space division systems in accordance with the invention exhibit internal stretch characteristics, with respect to space divider surfaces, battens and frames.

[0107] Still further, another aspect of space divider systems in accordance with the invention include the use of digital storage. For example, storage disks can be contained within fabric of the space dividers. These storage disks can

be coupled to external equipment such as laptop computers. Such laptops and other powered equipment may be energized through other components associated with the space dividers. Still further, digital storage can be provided in the form of microprocessors or other similar elements, having software for functions such as sound management and the like.

[0108] Still further, space divider systems in accordance with the invention can provide digital programming and switching functions. In general, these functions, along with other aspects of space division systems in accordance with the invention harness the effect of the semiconductor development and the effect of miniaturization. In this regard, the space division systems in accordance with the invention provide for embedment and integration of electronic and lighting components.

[0109] Still further, space division systems in accordance with the invention can comprise integration of solid state lighting (SSL). This lighting can be utilized for functions such as providing for color changes of space dividers themselves. Still further, lighting functions can provide for the signaling of interior or exterior circumstances. For example, lighting associated with the space dividers can be utilized to provide wayfinding. Signaling can also be utilized to indicate, for example, that a person is "in" within a particular working space.

[0110] Space division systems in accordance with the invention can also comprise integration and distribution of power. In particular, space division systems in accordance with the invention provide for DC power distribution. They also permit flexible use of 12-volt applications.

[0111] With respect to specifics of space division systems in accordance with the invention, they can include channel voids within space dividers, with the voids being located at differing heights. These voids can be utilized to carry power lines, lighting, digital storage and other components.

[0112] Still further, space division systems in accordance with the invention provide for modification and reconfiguration of the appearance of space divider fabrics. Color change can be provided, for example, through the use of solid state lighting embedded within channel voids of the space dividers. In addition, appearance changes can be made to occur through the use of functional control of conventional lighting.

[0113] Space dividers employed in space division systems in accordance with the invention can also provide for acoustical ameliorations. For example, space divider fabrics can employ physical sound attenuation material. Also, components associated with the space division system can provide for functional control of sound management systems and the like. Further, a primary aspect of space division systems in accordance with the invention relates to the totality of the foregoing principles.

[0114] Turning to FIG. 1, the particular example of the space division system 100 illustrated therein shows a space divider 102 vertically suspended from a rail system 104. The rail system 104 includes a rail 106 with a pair of hanger clips 108 which are releasably secured to the rail 106 and capable of being moved along a continuum of the length of the rail 106. Support rods 110 depend downwardly from the hanger clips 108 and are secured to the space divider 102. Prefer-

ably, the support rods **108** are adjustable in length so that the height of the space divider **102** may also be adjustable. Connection of the support rods **110** to the space divider **102** may be accomplished by any number of suitable means. For example, the lower terminating ends of the support rods **110** may be located within grommet holes (not shown) at the top portion of the space divider **102**. Such grommet holes may be spaced apart in a manner so as to provide variation in the location of interconnections of the support rods **110** to the space divider **102**.

[0115] As earlier stated herein, the hanger clips **108** can be characterized as “quick release” and “quick connect” elements. That is, the hanger clips **108** are advantageous for rapidly reconfiguring the physical locations of space dividers **102** relative to the rail system **104**. General concepts associated with the rail system **104**, and more specific configurations of elements such as the hanger clips **108**, are disclosed in the commonly assigned U.S. Provisional Patent Application Ser. No. 60/408,149, entitled “Rail System” and filed Sep. 4, 2002.

[0116] The space divider **102** may include an upper structural batten **112**. The upper structural batten **112** provides, in part, for “shape holding” of the space divider **102**. Extending downwardly from the structural batten **112** is the main body **114** of the space divider **102**. The main body **114** may be of a fabric which is substantially opaque, so as to generally provide a visual privacy curtain. Associated with the main body **114** is lighting technology, which may be in the form of solid state lighting (SSL) technology, such as LED lights. For example, embedded within the main body **114**, in a manner so as to be visible to a person near the space divider **102**, are a series of LED lights **116** arranged in a horizontal configuration. Further solid state lighting, which may also be in the form of LED lighting, is structured as arrow lighting **118** shown near the bottom of the main body **114**. In emergency situations, the arrow lighting **118** may be activated (in any of a number of appropriate control arrangements) so as to activate all of the arrow lights **118** or, alternatively, the arrow lights **118** may be activated in a manner so that they are sequentially “pulsed” so as to create the effect of “pointing” in a particular direction to show an appropriate direction of egress in an emergency situation.

[0117] In addition to the concept of using arrow lighting **118**, other types of functional signaling can be provided. For example, solid state lighting or other types of lighting could be utilized in combination with other elements so as to signal various other internal and external situations. For example, solid state lighting associated with the space dividers **102** could be utilized to indicate if an individual is “in” a particular workspace or, alternatively, is absent. Numerous other types of signaling could be utilized with the solid state lighting associated with the space dividers **102**.

[0118] The space divider **102** also includes a lower hemmed section **120** having a weighted insert as described in subsequent paragraphs herein with respect to other drawings. The weighted insert within the lower hemmed section **120** may also be utilized for purposes of “shape holding.” With respect to the rail **106**, hanger clips **108** and support rods **110**, various types of configurations may be utilized. One type of configuration is disclosed in the commonly assigned U.S. Provisional Patent Application Ser. No. 60/408,149, entitled “Rail System” and filed on Sep. 4, 2002.

[0119] FIG. 2 illustrates a plan view of an office environment showing various configurations of space dividers of a space division system according to the invention, in differing configurations. For example, FIG. 2 illustrates use of a wall curtain **130** having somewhat of a “hooked” configuration. A further space divider **132** is illustrated as showing a series of “S-shaped” configurations, which may be utilized to provide a series of computer workstations or the like. Conference tables **134** are illustrated as being somewhat enclosed through the use of the space dividers **130**, **132**.

[0120] In addition to the foregoing, space divider **136** is shown as primarily enclosing a privacy station **138**, which may be utilized for telephone calls or the like. Other areas may be partitioned or otherwise have space dividers of the space division system in a manner so as to provide aesthetics, such as space dividers **140** and **142**. The various configurations of the space dividers illustrated in FIG. 2 can provide for various types of spaces. With the interconnection of space dividers such as **130**, **132** and **140**, **142**, the interconnections can be provided through the use of splines. The spline interconnections are illustrated within the drawings. With the spline interconnections, reconfigurations of the various space dividers is not limited to movement along specific line segments. Instead, with the use of the splines, movement can occur with respect to the space dividers and the configurations to configurations having a curve of any reasonable radius.

[0121] FIG. 3 illustrates a side-elevation view of a space divider in accordance with the invention. FIG. 4 illustrates a partial sectional end view of the same. With reference to FIGS. 3 and 4, the space divider **150** may be comprised of a translucent and stretchable material. FIG. 4 illustrates how the material **152** may be woven into the wall configuration. The space divider **150** may also have a power batten **154** positioned at the top thereof, for purposes of carrying power such as low voltage DC power. The power batten **154** may provide power to a DC power cable **156** or, alternatively, an AC power cable **158**. The DC power cable **156** may carry DC low voltage power and is accessible through power batten openings **160**. The power batten openings **160** would be accessible to internal linear voids existing within the three-dimensional knitting of the main body **150**. The linear voids are illustrated as voids **162** in FIGS. 3 and 4.

[0122] FIG. 5 illustrates another space divider **170** which may be formed of a woven fabric material. For example, one type of woven material which may be utilized is commonly referred to in the industry as “cattle mattress” material. The cattle mattress material of the space divider **170** provides linearly directed pockets **172** which may be segmented by the use of brackets **174**, as illustrated in FIG. 6.

[0123] FIG. 7 is a perspective view of two curved space dividers, forming a space division system **180**. The space division system **180** includes a first space divider **182** and a second space divider **184**. In general, FIG. 7 illustrates a structural configuration which may be achieved with respect to aesthetic curvature, through the use of the space dividers **182**, **184**. Also, FIG. 7 illustrates use of not only the rails **106**, but also the use of a cross rail **186**. The configuration of a cross rail **186**, with the use of vertically disposed partitions, is described in the commonly assigned U.S. Provisional Patent Application Ser. No. 60/408,149, entitled “Rail System” and filed on Sep. 4, 2002.

[0124] FIG. 8 illustrates a sectional end view of the space divider 184. This view shows the structural batten 112 at the top end thereof, with the fabric extending downwardly therefrom. Linear or substantially horizontal voids 188 are provided at spaced-apart intervals downwardly along the space divider 184.

[0125] The space divider 184 terminates at its lower portion with the lower hem 120. The lower hem 120 is shown as having a weighted insert 190. The weighted insert 190 is utilized to maintain the space divider 184 in a stable position. That is, the weighted insert 190 provides for “shape holding” for the space dividers of the space division system 100. In a particular example illustrated in FIG. 8, the weighted insert 190 may be a tubular section 192 fitted within the hem 120, and filled with material such as sand.

[0126] FIG. 8A is similar to FIG. 8, but shows the lower hem 120 as capturing a tubular insert 192. The tubular insert 192 may be a flexible sheath 194 consisting of rubber or the like. The sheath 194 may be of relatively substantial weight in and of itself or, alternatively, may be weighted by the use of sand or other materials carried within the sheath 194. The weighted insert 192 can include an end tab 196 which may be interconnected to a cooperating recess or similar connecting means in the weighted insert 192 associated with an adjacent space divider 184. In this manner, the weighted inserts of adjacent space dividers may be interconnected together.

[0127] FIG. 9 is a sectional end view (taken along section lines 9-9 of FIG. 7) showing an end portion of the space divider 184. In this particular configuration, a power batten 200 extends downwardly so as to form an end hem of the space divider 184. A low voltage DC power cable 202 may be extended downwardly through the power batten 200. In addition, it is also possible to extend a communication cable 204 through the batten 200. The batten 200 is formed by taking the space divider 184 and turning it rearward upon itself, and then connecting the end of the space divider 206 to another portion of the space divider 184 through the use of a spring clip 208 or a similar releasable securing means.

[0128] FIG. 10 illustrates an interconnection between the space divider 182 and 184 which may be employed in accordance with the invention. In this particular embodiment, a power batten 210 (having communication cables 204) is formed at the intersection of the space dividers 182 and 184. The space dividers 182 and 184 are releasably coupled together through the use of a pair of spring clips 208.

[0129] In accordance with the foregoing, the space division system 100 in accordance with the invention provides for the rapid addition and deletion of space dividers. In addition, the elements of the space division system 100 exhibit internal stretch characteristics, with respect to space divider surfaces, battens and frames. These internal stretch characteristics provide for a continuum of configurations, with the spline interconnections providing for curvature of any reasonable radius.

[0130] FIG. 11 is a close up section of the end portion of the space divider 184, similar in form to FIG. 9. However, FIG. 11 further illustrates the use of 3D translucent material for the space divider 184. Further, FIG. 11 illustrates communication cables 212 which may extend through a pre-woven pocket 214 of the translucent space divider 184.

[0131] FIG. 12 illustrates a “close up” view of the intersection between the space dividers 182, 184. FIG. 12 is a view similar in scope to FIG. 10, but further illustrates power/communication cables 216 extending through pre-woven pockets 218 of the space dividers 182, 184.

[0132] FIG. 13 is a close up section view of an end portion of the space divider 184 (similar to FIG. 11), but illustrating the space divider 184 as comprising a woven fabric material 220. Various types of woven materials may be utilized as material 220. For example, in the particular embodiment described and illustrated herein, the woven material 220 may be a material which is characterized as “cattle mattress” material. FIG. 14 is a close up section similar in scope to the close up section illustrated in FIG. 12, but showing the two space dividers 182, 184 as employing cattle mattress material 220.

[0133] FIG. 15 is an elevational view of space dividers 230. More specifically, the space dividers 230 include a series of internal linear voids 232 through which linear LED lighting strips may be inserted. Referring to both FIGS. 15 and 16, such an LED lighting strip is illustrated in FIG. 16 as LED strip 234. LED strip 234 will have a sequential series of LED lights 236 extending along the lighting strip 234. The lighting strip 234 will be positioned within the linear void 232. For purposes of carrying other elements, such as power cables or communication cables, additional linear voids, such as linear voids 238 and 240, may also be horizontally located within the space dividers 230. FIG. 15 also illustrates the use of a series of LED power supplies 242 which may be connected to LED power lines 234. In turn, the LED power lines 234 may be connected in any appropriate manner to the LED lighting strips 236. Further, additional power may be provided, such as with the utilization of a 12-volt DC utility power supply line 246.

[0134] The particular LED lighting strips 234 may comprise, for example, yellow linear flex side LED lighting strips, having a configuration of approximately 2 inches by 24 feet. Other interconnections may also be employed with the space dividers 230, such as Internet connections and the like. FIG. 17 is a side elevational view of a similar set of space dividers 250. The sections 250 are similar to the sections 230 previously described with respect to FIG. 15. In addition, these sections carry LED power supplies 242 and LED power lines 244, in addition to a DC power line 246. However, as illustrated in FIG. 18, the LED lighting strips 260 are turned in a different direction from the LED lighting strips 234 illustrated in FIG. 16. In this manner, the actual light intensity and light diffusion at the opposing surfaces of the space dividers 250 will be different than that of the sections 230. Further, FIGS. 17 and 18 illustrate the use of two LED lighting strips 260.

[0135] FIG. 19 is a further embodiment of a pair of space dividers 270, with FIG. 19 showing a side elevational view thereof. With respect to FIGS. 19 and 20, a series of LED power supplies 242 are shown, interconnected to LED power lines 244. Correspondingly, a DC power line 246 is also illustrated. With the space dividers 270, linear voids 272 are provided, one of which carries an LED lighting strip 274 having the substantially “flat” configuration illustrated in FIG. 20. In this particular configuration, a differing light intensity and light dispersion will be seen on the left side surface of the space divider 270 (as viewed in FIG. 20),

while a relatively opaque view will be found from the right side of the space divider 270 (again as viewed in FIG. 20).

[0136] FIGS. 21, 22 and 23 illustrate similar space dividers utilizing LED internal lighting technology. FIG. 21 illustrates space dividers 290, having linear voids 292 positioned at the lower portion thereof. As illustrated in FIG. 22, each of the linear voids 292 carries a flat-configured LED lighting strip 296 facing toward the left side of the space divider 290 illustrated in FIG. 22. Alternatively, FIG. 23 is similar in form to FIG. 22, and illustrates the upper LED flat-configured lighting strip 298 as facing to the right side of the space divider 290, while the lower LED flat-configured lighting strip 298 faces toward the left side of the space divider 290. Again, the particular light intensity, diffusion and color “wash” which will be associated with the space dividers 290 will be dependent upon the spacing and the configuration of the LED lighting strips. It should be understood that the lighting strip configurations described herein are merely examples of those which may be utilized with a space division system in accordance with the invention. Numerous other LED lighting strip configurations could be utilized, without departing from the spirit and scope of the novel concepts of the invention.

[0137] FIG. 24 illustrates a pair of space dividers 300 having a linear or horizontal void 302 wherein an LED lighting strip 304 is embedded. The LED lighting strip 304 includes a series of arrows which can be utilized for emergency directional lighting, and may be sequentially “pulsed” so as to illustrate a direction of egress for emergency evacuation. For purposes of emergency directional lighting, various additional electrical equipment may be required. For example, it is not uncommon for electrical and other building codes and regulations to require the use of separate power sources for emergency lighting. In such event, such power sources may be required to be electrically interconnected with the LED lighting strip 304. Also, the lighted arrows of the LED lighting strip 304 may be utilized for purposes other than emergencies. As an example, the arrows of the LED lighting strip 304 may be utilized to provide “wayfinding” for purposes of directing visitors to the commercial interior to appropriate locations within the interior, as well as for purposes of emergencies. Along with other appropriate power and lighting equipment, the arrows of the LED lighting strip 304 may be utilized, for example, to direct visitors in a library to appropriate book classification sections. Numerous other wayfinding uses may also employ the use of arrows or similar directional indicators of the LED lighting strip 304. For example, and as earlier mentioned, lighting may be utilized for indication of external and internal situations. For example, lighting may be associated with the space dividers in a manner so as to indicate whether an individual is “in” a particular workspace.

[0138] FIGS. 25 and 26 illustrate a pair of space dividers 310, with LED lighting technology utilized externally of the space dividers 310. More specifically, the space dividers 310 include a curtain 314 mounted from the top portion of the space divider 310. Depending forwardly and horizontally from the space dividers 310 is an LED lighting strip support 316, which may be appropriately secured to a linear void 312 of the space dividers 310. Positioned downwardly from the support 316 is a series of LED lights. The LED lights may be of appropriate colors, and will provide what may be characterized as an external “wash” and a color “wash” over

the lower portion of the side surfaces of the space dividers 310, below the curtain 314. This color wash can be modified in intensity and with respect to diffusion dependent upon the intensity and color of the LED lights 318, and of the particular materials from which the space dividers 310 are constructed.

[0139] FIG. 27 illustrates a pair of space dividers 320 showing a low voltage DC power line 328, communications cabling 326, AC power 322 and AC power line 324. The AC power line 324 terminates in a pair of electrical receptacles 330. A computer 332 may be energized through the electrical receptacles 330. Data and communication signals may be transmitted from the computer 332 through a communications signal junction box or modem 334, and outwardly through the communications cabling 326. In this manner, the space dividers 320 provide power and networking technology. FIG. 28 is a side elevational view of space dividers 340, similar in structure to the space dividers 320 illustrated in FIG. 27. In this particular instance, the space dividers 340 are illustrated showing use of wall-connected task lighting technology. The configuration employs a task light 342 illustrated in FIGS. 28 and 29. The task light 342 utilizes low voltage DC power and LED lighting technology. As illustrated in FIGS. 28 and 29, the LED task light 342 includes a rectangular LED marker 344 at the terminus of the task light 342. Extending downwardly from the marker 344 is a rigid foam core 346. The rigid foam core 346 is adjacent a flexible joint 348. A fabric cover 350 extends downwardly and angularly from the flexible joint 348. The fabric cover 350 is interconnected to an appropriate securing bracket 352, which is secured to the space divider 340 by appropriate means. For example, Velcro or a similar securing means could be employed. The task light 342 may be utilized to provide appropriate light for use of a computer screen 354.

[0140] In addition to the foregoing, the space dividers and associated channel voids can be utilized with data storage technology. For example, the computer 332 or other types of computerized or communications equipment could be releasably attached to a data storage device embedded within voids of the space dividers. These data storage devices could be in the form of disks or similar devices. Also, for example, data storage and programming devices such as microprocessors could also be embedded within voids of the space dividers, for releasable interconnection to other types of equipment, such as sound management technology and the like. With respect to all the foregoing, the space division system 100 in accordance with the invention provides for actual data storage embodied and embedded within the space division system itself. In this manner, the space dividers themselves are not merely fabrics within frames having battens and the like, but are elements which take advantage of today’s miniaturization and advancements in technology, so as to provide data storage, access to programmable devices and the like.

[0141] FIG. 30 illustrates a curved configuration of a space divider 360 showing the use of the task light 342 therewith. FIG. 31 is an elevational view of a pair of space dividers 370, showing the use of DC low voltage technologies with a pair of task lights 342. FIG. 31 further shows the energizing of a coffee maker 343, through the power supplied to the space dividers 370. FIG. 32 illustrates another pair of space dividers 380, showing the space dividers 380 in use in an office environment with technologies. For

example, this office environment may include a telephone **382**, MP3 player **384**, laptop **386** and fan **388**. FIG. **33** illustrates another pair of space dividers **390**, showing use with technology which may be associated with a temporary work or gathering space. For example, the configuration illustrated in FIG. **33** includes a phone **382**, a set of wireless headphones **384**, teleconferencing screen **386** and various other accessories.

[0142] FIG. **34** is substantially similar to FIG. **2**, but further illustrates the use of a projector **400** in use with a screen **402** secured to the space divider **130**. The foregoing drawings illustrate interconnections of various types of technological and other functional accessories through the space dividers. Further, the drawings illustrate the use of velcro clips at attachment points. As earlier stated, data storage devices and switches can also be employed with the space dividers.

[0143] Still further, other types of equipment may be utilized. For example, both wired and wireless headphones may be employed and energized through the DC power distribution systems. Still further, projection equipment may be utilized, with projection screens releasably attached to fabrics of the space dividers. This was illustrated with respect to projector screen **402**, coupled to the space divider **130**. Still further, however, projection may occur upon fabric surfaces of the space dividers themselves. This can be provided through the use of monofilaments.

[0144] FIGS. **35**, **36** and **37** illustrate alternative embodiments and configurations of space dividers **410**, **420** and **430**, respectively, and illustrate various plan views of these space dividers so as to provide visual privacy. These space dividers may be in the form of what is characterized as “technology curtains,” and create flexible spaces for individual and small group uses. In addition, the enclosures provided by these space dividers exhibit daily flexibility for project teams. FIGS. **38** and **39** show other configurations of the technology curtains, identified as technology curtains **432** and **434**. These technology curtains can be characterized as being configured in a “flutter” form configuration. FIGS. **38** and **39** show two alternative embodiments of the “flutter” form configuration. With these configurations of the technology curtains, relatively more efficient place making is provided. In addition, these configurations essentially maximize characteristics which tend to be unique to “hung” fabric. These arrangements also afford a greater variety of space division, and also more or a greater spatial “sense.” In addition, these “flutter” form configurations create more receptacle spaces than what are characterized as “booth” walls. The “flutter” form configurations also provide relatively greater flexible niche scale. In general, the embodiments of FIGS. **35**, **36** and **37** show movement from “shared” to “separate” configurations. The enclosures formed by the space dividers within these drawings provide for substantial flexibility for project teams and the like. Still further, the configurations in FIGS. **38** and **39** provide for individuals’ space along edges, in addition to collective action. That is, adjacency is provided, but with relatively more privacy.

[0145] FIGS. **40** and **41** illustrate technology curtain configurations **436** and **438**. These configurations may be characterized as “quad-place” configurations. In these illustrations, the spaces shown move collectively to a less flexible,

central passageway which grow so as to accommodate group work. The configurations comprise technology curtains which would provide both visual privacy and sound absorption. Advantages associated with “quad-place” configurations relate to the responsiveness to fluid conditions of collaborative work practices. In addition, these configurations provide daily flexibility for project teams, and can be grouped as “sub-centers” around what may be characterized as a “silent center.”

[0146] FIGS. **42**, **43** and **44** illustrate the use of technology curtains **440**, **442** and **444**, respectively, and exemplify what can be characterized as “triplace” configurations. These technology curtain configurations provide both visual privacy and sound absorption. Benefits include responsiveness to fluid conditions of collaborative work practices, in addition to daily flexibility for project teams. In addition, these triplace configurations can be grouped as “sub-centers” around a silent center. More specifically, FIG. **42** illustrates a configuration having three spaces. Correspondingly, FIG. **44** illustrates a configuration with two spaces, while FIG. **43** illustrates a single space configuration.

[0147] FIG. **45** illustrates the actual use of a translucent space divider **450**.

[0148] As earlier referenced herein, the space division system **100** with technology provides a means for facilitating control and reconfiguration of control relationships among various functional components which may be utilized with the space division system **100**. For purposes of describing the concept of establishing controlling relationships among various controlled and controlling components which may be associated with the space division system **100**, reference is made to the commonly assigned U.S. Provisional Patent Application Ser. No. 60/374,012, entitled “Switching/Lighting Correlation System” and filed on Apr. 19, 2002. The contents of the aforesaid patent application are hereby incorporated by reference herein.

[0149] In this regard, it is relatively apparent that it would be favorable to establish control relationships among switches and lights, and have the capability of reconfiguring the same. Other control relationships may also be worthwhile. For example, FIG. **46** illustrates a user employing a control wand **460** (to be described in subsequent paragraphs herein) for purposes of establishing control of an LED lighting strip **462**. FIG. **46** also illustrates the location of a wall-attached task light **464**. These elements are associated with a space divider **466**. FIG. **47** is similar to FIG. **46**, but further illustrates the user employing the control wand **460** for purposes of establishing control of the task light **464**. An example of the control wand **460** is illustrated in FIGS. **48**, **49** and **50**. With reference thereto, the control wand **460** may be of an elongated configuration. At one end of the control wand **460** is a light source **470** which, preferably, would generate a substantially collimated beam of light. In addition to light source **470**, the control wand **460** may also include an infrared (IR) emitter **472**, for transmitting infrared transmission signals to corresponding IR receivers associated with the LED lights **462** or task light **464**, in addition to switches or the like which may control these functional accessories.

[0150] The control wand **460** may also include a trigger **474**, for purposes of initiating transmission of IR signals. Still further, the wand **460** may include mode select switches

such as mode select switch **476** and mode select switch **478**. These mode select switches may be utilized to allow manual selection of particular commands which may be generated using the wand **460**. The control wand **460** may also utilize controllers (not shown) or similar computerized devices for purposes of providing electronics within the wand **460** for use with the trigger **474**, mode select switches **476**, **478**, light source **470** and the IR emitter **472**. As earlier mentioned, an example of the use of such a wand, with the attendant commands which may be generated using the same, is described in the commonly assigned U.S. Provisional Patent Application Ser. No. 60/374,012, entitled "Switching/Lighting Correlation System" and filed on Apr. 19, 2002.

[0151] Referring back to FIGS. **46** and **47**, the user may employ the wand **460** to transmit signals to controllers (not shown) associated with the LED lights **462** and task light **464**. The capability of essentially "programming" controlled relationships among the various accessories associated with the space division system **100** requires the capability of transmitting and receiving communication signals among the various functional accessories. In this regard, infrastructure systems may be employed. An example of such an infrastructure system which may be employed with the space division system **100** in accordance with the invention is described in detail in the commonly assigned U.S. Provisional Patent Application Ser. No. 60/408,149, entitled "Rail System" and filed on Sep. 4, 2002.

[0152] FIG. **51** is a perspective view of a particular configuration utilizing space divider **500** in a curved configuration, with task lights **502**. Such an arrangement could be utilized within a library, study hall or restaurant configuration. Also, mention should be made that space divider **500**, as well as other space divider configurations illustrated and described herein, may be utilized with various types of ceiling structures. One such ceiling structure is illustrated in the commonly assigned U.S. Design Pat. application Ser. No. 29/166,803, entitled "Design for Articulating Ceiling" and filed Sep. 4, 2002.

[0153] Various types of appliances and technologies may be utilized with the space dividers of the space division system **100**, in addition to those that have been expressly described in detail herein. For example, sound apparatus such as speakers and the like may be integrated into the various space dividers of the space division system **100**. Such speakers may be energized through power and communication sources described herein, or through other energizing means, including batteries and the like. Still further, the speakers could be selectively enabled as desired, and controlled with the control wand **460** and control processes described earlier herein.

[0154] Still further, noise masking processes could be employed with the use of these speakers, in addition to general acoustical control arrangements. Still further, the noise masking arrangements employing the speakers could be integrated within a virtual structure associated with the space division system **100**. In general, various types of speakers, noise masking, acoustical control and other equipment and processes could be employed with the technologies of the space division system **100**, and powered with the method and apparatus described herein, as well as with other energizing arrangements (e.g. batteries).

[0155] Still further, the space dividers of the space division system **100** may have application in situations which require the employment of security measures. In this regard, it may be advantageous to construct space dividers of the space division systems with materials having a substantial capability of resisting penetration. An example of one such material is known as Kevlar® brand fiber, with the term Kevlar® being a registered trademark of E.I. duPont de Nemours and Company. Kevlar® brand fiber is p-phenylene-teterephthalamide. Kevlar® brand fiber combines relatively high strength with light weight. Kevlar® brand fiber is within a family of nylon fibers known as Aramids. Specifically, and is within a polyamide, with amide groups attached at carbons 1 and 4. For purposes of security, various of the space dividers of the space division system **100** may be constructed of Kevlar® brand fiber.

[0156] Still further, will respect to security and safety, the space dividers of the space division system **100** may be constructed of fire resistant or fire proof materials. One such material which also falls within the family of Aramids is known as Nomex® brand fiber. The term Nomex® is also a trademark of E.I. duPont de Nemours and Company. Nomex® brand fiber is commonly utilized for purposes of making fire proof clothing. Unlike Kevlar® brand fiber, Nomex® brand fiber has amide groups attached at carbons 1 and 3. It is not uncommon to construct materials which are blends of both Nomex® and Kevlar® brand fibers. It may therefore be advantageous to construct the space dividers of the space division system **100** with materials employing Nomex® brand fiber or other materials having fire proof properties, in addition to Kevlar® brand fiber or other materials which substantially resist penetration.

[0157] Another configuration of the space division system **100** may also be important with regard to security and safety. Specifically, it may be advantageous to incorporate means in the space division system **100** for releasably securing space dividers and other elements of the space division system **100** to a floor structure. Various types of securing means could be employed with the space dividers, lower battens and the like. However, it would be preferable to insure that the means for securing elements of the space division system **100** to the floor structure still permit release of these elements from the floor structure without significant effort.

[0158] Turning to other apparatus and concepts which may be employed with a space division system in accordance with the invention, the lighting configurations described herein (such as LED lighting strip **462**, task light **464** and the like) may employ various types of controlling apparatus in the form of enabling switches for controlling the state of the lighting elements or other electrical apparatus, appliances, computerized equipment and the like. In this regard, various types of switches may be employed. These switches may be in the form of conventional switches having differing spatial positions for "on" and "off" states. However, other types of switches may also be employed. For example, the space division system **100** in accordance with the invention may employ optical switches for controlling lighting elements, electrical appliances and the like. With respect to use of the control wand **460** previously described herein, the switches may be associated with sensors which can detect spatial signals transmitted from the wand **460**. Further, physically operable switches such as pressure switches may also be employed. Still further, various types of motion sensing

devices may be employed to enable and disable switches and associated equipment. These and other types of switches may also be employed with the use of radio frequency identification (“RFID”) systems, whereby, for example, an individual entering a room with a specific RFID badge may cause switches and their associated sensors to identify the individual and configure lighting elements and other equipment associated with the space division system **100** to specific states. Still further, all of these types of switches and other controlling devices may be communicatively coupled to a power and communications network associated with the space division system **100**. Such a network is generally described in the commonly assigned U.S. Provisional Patent Application Ser. No. 60/408,149, entitled “Rail System” and filed Sep. 4, 2002.

[0159] In summary, a space division system **100** has been disclosed in accordance with the invention, which provides for movable and internally reconfigurable space dividers, incorporates various technologies and is not limited in size or expansion capability. The system is internally reconfigurable, light weight and employs quick-release elements. In this regard, joined space dividers can be rapidly added and deleted, and the use of splines provides for movement from line segment configurations to configurations having a curve of any radius.

[0160] In the same regard, internal stretch characteristics are exhibited by space divider surfaces, battens and frames. Digital storage is also provided within voids of fabrics associated with the space dividers. Still further, digital programming and switching is also provided. In this manner, space division systems in accordance with the invention harness the effect of miniaturization, through the embedment and integration of electronic components. In addition, solid state lighting is integrated within the system, having capabilities such as changing color appearances of space dividers and the like. In addition, signaling of interior and exterior circumstances is provided. In the same regard, space division systems in accordance with the invention incorporate integration and distribution of power, particularly DC power and the flexible use of 12-volt applications.

[0161] With regard to structure, channel voids are provided within space dividers at differing heights. Space divider fabrics can be modified in appearance, such as providing color changes using solid state lighting. Color appearance can also be modified through the functional control of conventional lighting. Space division systems in accordance with the invention can also exhibit acoustical ameliorations, through the use of physical sound attenuation material, functional control of sound management systems and the like.

[0162] It will be apparent to those skilled in the pertinent arts that other embodiments of space division systems in accordance with the invention may be designed. That it, the principles of a space division system for configuring control among functional accessories and for the connection of functional accessories through a space division system are not limited to the specific embodiments described herein. For example, various configurations of certain components of the space division system **100** may be utilized, without departing from the spirit of the invention. Further, numerous types of technologies may be utilized with the space division system **100**, without departing from the novel concepts of

the invention. Such technologies may include the use of sound design, radio frequency identification (“RFID”), infrared spatial transmissions and other technologies. Accordingly, it will be apparent to those skilled in the art that modifications and other variations of the above-described illustrative embodiments of the invention may be effected without departing from the spirit and scope of the novel concepts of the invention.

What is claimed is:

1. A space division system for use with a supporting infrastructure, with the supporting infrastructure providing for distribution of electrical and communication signals, said space division system comprising:

a plurality of vertically disposed space dividers;

support means coupled to said supporting infrastructure and to said space dividers for moveably supporting said space dividers from said supporting infrastructure;

means for relocating said space dividers at selected locations relative to said supporting infrastructures; and

means for effecting a plurality of spatial configurations among said space dividers.

2. A space division system in accordance with claim 1, characterized in that said space dividers comprise pocketed dividers within a three dimensional knit in a layered structure.

3. A space division system in accordance with claim 1, characterized in that said space division system comprises splines for interconnecting space dividers in a manner so that said space dividers can be configured with varying radius.

4. A space division system in accordance with claim 1, characterized in that said means for effecting a plurality of spatial configurations among said space dividers comprises means for effecting non-modular and flexible configurations.

5. A space division system in accordance with claim 1, characterized in that at least one space divider comprises a three-dimensional knit having relatively large pockets.

6. A space division system in accordance with claim 1, characterized in that said plurality of spatial configurations comprises a plurality of said space dividers having a curvilinear structure as a function of stretching material of said space dividers.

7. A space division system in accordance with claim 1, characterized in that a subset of said plurality of configurations comprises a plurality of said space dividers having a curvilinear structure.

8. A space division system in accordance with claim 1, characterized in that said supporting means are adjustable in a manner so that a height of at least a subset of said plurality of space dividers may be adjustable.

9. A space division system in accordance with claim 1, characterized in that at least one of said plurality of space dividers comprises:

an upper structural batten;

a main body extending downwardly from said structural batten; and

said main body being constructed of a fabric which is substantially opaque.

10. A space division system in accordance with claim 8, characterized in that said space divider comprises a lower hemmed section having a weighted insert.

11. A space division system in accordance with claim 1, characterized in that said space dividers comprise at least one space divider having a hook configuration.

12. A space division system in accordance with claim 1, characterized in that said partitions comprise at least one space divider having a configuration with a series of S-shaped curvatures, where said S-shaped curvatures form partially enclosed workstations.

13. A space division system in accordance with claim 1, characterized in that said space dividers comprise at least one space divider consisting of a translucent and stretchable material.

14. A space division system in accordance with claim 1, characterized in that at least one of said space dividers comprises a space divider formed of a woven material.

15. A space division system in accordance with claim 13, characterized in that said woven material consists of a cattle mattress material.

16. A space division system in accordance with claim 1, characterized in that at least one of said space dividers comprises a space divider having a weighted insert consisting of a tubular section fitted within a lower hem of said at least one partition.

17. A space division system in accordance with claim 16, characterized in that said tubular section is filled with sand.

18. A space division system in accordance with claim 16, characterized in that said tubular section comprises a flexible sheath consisting of rubber.

19. A space division system in accordance with claim 16, characterized in that said weighted insert comprises an end cap interconnected to a cooperating means of a weighted insert associated with an adjacent space divider.

20. A space division system in accordance with claim 1, characterized in that at least two adjacent ones of said space dividers are releasably coupled together through a quick release and quick connect mechanism.

21. A space division system in accordance with claim 20, characterized in that said mechanism comprises spring clips.

22. A space division system in accordance with claim 1, characterized in that at least one of said space dividers comprises a space divider consisting of three-dimensional translucent material.

23. A space division system in accordance with claim 1, characterized in that at least one of said space dividers comprises a space divider structured in a flutter form configuration.

24. A space division system in accordance with claim 1, characterized in that at least one of said space dividers comprises a space divider having a quad-place configuration.

25. A space division system in accordance with claim 1, characterized in that at least one of said space dividers comprises a space divider having a tri-place configuration.

26. A space division system for use with a supporting infrastructure, with the supporting infrastructure providing

for distribution of electrical and communication signals, said space division system comprising:

a plurality of vertically-disposed space dividers;

support means coupled to said supporting infrastructure and to said partitions for supporting said space dividers from said supporting infrastructure;

means for relocating said space dividers at selected locations relative to said supporting infrastructure; and

electrical and communication connection means for transmitting and/or receiving said electrical and communication signals from said supporting infrastructure, and so as to apply said electrical and communication signals to functional accessories releasably coupled to said subset of said space dividers.

27. A space division system in accordance with claim 26, characterized in that said subset of said space dividers comprises main bodies having lighting means embedded within said main bodies, in a manner so as to be visible to a person substantially adjacent said space dividers.

28. A space division system in accordance with claim 27, characterized in that said lighting means comprises solid state lighting technology.

29. A space division system in accordance with claim 28, characterized in that said solid state lighting technology comprises a plurality of LED lights.

30. A space division system in accordance with claim 28, characterized in that said solid state lighting technology comprises arrow lighting positioned adjacent a lower portion of said main bodies.

31. A space division system in accordance with claim 30, characterized in that said space division system further comprises means for simultaneously activating all arrow lights of said arrow lighting or, alternatively, activating said arrow lights of said arrow lighting in a manner so that said arrow lights are sequentially pulsed so as to create an effective pointing in a particular direction;

32. A space division system in accordance with claim 31, characterized in that said connection means comprises means for interconnecting telephone apparatus to communication signaling of said supporting infrastructure.

33. A space division system in accordance with claim 26, characterized in that said subset of said space dividers comprise space dividers having power battens positioned at a top portion thereof, for purposes of carrying power.

34. A space division system in accordance with claim 33, characterized in that said power comprises both low voltage DC and AC power.

35. A space division system in accordance with claim 33, characterized in that said power battens have openings accessible to internal linear voids existing within knitting of said main bodies, and power cables may be extended within said voids.

36. A space division system in accordance with claim 26, characterized in that said subset of said space dividers comprises space dividers consisting of a structural batten at the top ends thereof, with fabric extending downwardly therefrom, and with linear voids formed within said fabric, in spaced apart intervals downwardly along said space dividers.

37. A space division system in accordance with claim 26, characterized in that said subset of said space dividers comprise space dividers having power battens extending

downwardly so as to form end hems of said space dividers, with low voltage DC power strips and/or communication cables extending through said power battens.

38. A space division system in accordance with claim 37, characterized in that said power battens are formed by taking sections of said space dividers and turning them rearward upon themselves, and then connecting ends of said space dividers to other portions of said space dividers through the use of releasable securing means.

39. A space division system in accordance with claim 26, characterized in that said subset of said space dividers comprises space dividers formed of translucent material and having communication cables extending through pre-woven pockets of said translucent space dividers.

40. A space division system in accordance with claim 26, characterized in that said subset of said space dividers comprises space dividers having a plurality of internal linear voids through which first linear LED lighting strips are inserted.

41. A space division system in accordance with claim 40, characterized in that said internal linear voids are horizontally located within said space dividers, and further carry power cables and communication cables.

42. A space division system in accordance with claim 41, characterized in that said first LED lighting strips comprise linear flex side LED lighting strips.

43. A space division system in accordance with claim 41, characterized in that said space dividers include global communications interconnections.

44. A space division system in accordance with claim 41, characterized in that said space dividers further comprise a second set of LED lighting strips turned in a different direction from said first LED lighting strips, so that actual light intensity and light diffusion at opposing surfaces of said space dividers may differ depending upon the particular sections.

45. A space division system in accordance with claim 35, characterized in that said linear voids carry LED lighting strips having a substantially flat configuration, with a particular light intensity and light dispersion as viewed on one surface of said space divider, while a relatively opaque view is produced on an opposing surface of said space divider.

46. A space division system in accordance with claim 26, characterized in that said subset of said space dividers comprises space dividers having LED lighting technology employed externally of said sections.

47. A space division system in accordance with claim 46, characterized in that said space dividers include curtains mounted from top portions of said space dividers, and LED lighting strip supports depend forwardly from said space dividers, and are appropriately secured to linear voids of said space dividers.

48. A space division system in accordance with claim 47, characterized in that positioned downwardly from said supports is a series of LED lights, having appropriate colors so as to provide an external color wash over a lower portion of said side surfaces of said space dividers, below said curtain.

49. A space division system in accordance with claim 47, characterized in that said color wash can be modified in intensity and with respect to diffusion dependent upon intensity and color of said LED lights, and dependent upon the particular materials from which said space dividers are constructed.

50. A space division system in accordance with claim 26, characterized in that said subset of said space dividers comprises space dividers having low voltage DC power lines, communications cabling, AC power and AC power lines.

51. A space division system in accordance with claim 50, characterized in that at least one of said AC power lines terminates in a pair of electrical receptacles, and conventional electrical appliances may be energized through said electrical receptacles.

52. A space division system in accordance with claim 50, characterized in that at least one of said AC power line terminates in a pair of electrical receptacles, and computerized apparatus may be energized through said electrical receptacles.

53. A space division system in accordance with accordance with claim 52, characterized in that data and communication signals are transmitted from said computerized apparatus through a communications signal junction box and outwardly through said communications cabling.

54. A space division system in accordance with claim 53, characterized in that said space dividers comprise electrical interconnections of at least one task light to said electrical signals of said supporting infrastructure.

55. A space division system in accordance with claim 54, characterized in that said task light comprises:

a rectangular LED marker at a terminus of said light;

a flexible joint;

a fabric cover extending downwardly and angularly from said flexible joint; and

said fabric cover is interconnected to a securing bracket which, in turn, is secured to one of said space dividers.

56. A space division system in accordance with claim 26, characterized in that said subset comprises space dividers having projection screens releasably secured thereto.

57. A space division system in accordance with claim 26, characterized in that at least a subset of surfaces of said space dividers comprises surfaces adapted for use as projection screens, with monofilaments.

58. A space division system in accordance with claim 26, characterized in that said system further comprises means for visually indicating external and internal circumstances associated with said space division system.

59. A space division system in accordance with claim 58, characterized in that said means for indicating external and internal circumstances comprises light means for visually indicating when an individual is within a particular workspace formed by said space dividers.

60. A space division system in accordance with claim 26, characterized in that said system further comprises data storage devices associated with said space dividers and releasably interconnectable to external electronic components.

61. A space division system in accordance with claim 26, characterized in that:

said system further comprises utilitarian elements associated with said space dividers, with said utilitarian elements comprising at least one controlling device;

said utilitarian elements further comprise at least one controlled device, with said controlled device having at least first and second states; and

said communications signals are utilized to effect a logical control relationship between said controlling device and said controlled device.

62. A space division system in accordance with claim 61, characterized in that said logical control relationship between said controlling device and said control device is reconfigured at least in part with said communications signals, in the absence of any physical relocation of any physical wiring associated with said controlling device and said controlled device.

63. A space division system in accordance with claim 61, characterized in that said system comprises at least one manually operable programming means for transmitting programming signals so as to effect said logical control relationship.

64. A space division system in accordance with claim 26, characterized in that:

said system further comprises a set of utilitarian elements associated with said space dividers; and

at least certain of said utilitarian elements are manually releasable from said space dividers.

65. A space division system in accordance with claim 26, characterized in that said system further comprises audio apparatus integrated with at least a subset of said plurality of vertically-disposed space dividers.

66. A space division system in accordance with claim 65, characterized in that said audio apparatus comprises a plurality of speakers energized from said electrical signals.

67. A space division system in accordance with claim 66, characterized in that:

said speakers comprise controlled devices;

said system further comprises at least one controlling device; and

said communication signals are utilized to effect a logical control relationship between said controlling device and said speakers.

68. A space division system in accordance with claim 67, characterized in that said system further comprises at least one manually operable programming means as said controlling device, for transmitting programming signals so as to effect said logical control relationship with said speakers.

69. A space division system in accordance with claim 26, characterized in that said system further comprises sound management apparatus for providing means for controlling perceptions of sound at spatial locations adjacent said space division system.

70. A space division system in accordance with claim 69, characterized in that said sound management apparatus is powered at least in part through said distribution of electrical signals.

71. A space division system in accordance with claim 66, characterized in that said speakers are utilized to generate noise masking audio signals for purposes of providing sound management at spatial locations around said space division system.

72. A space division system in accordance with claim 1, characterized in that said space division system is adapted for use with an articulating ceiling.

73. A space division system in accordance with claim 1) characterized in that at least a subset of said space dividers is constructed at least in part of materials having substantial capabilities of resisting penetration.

74. A space division system in accordance with claim 73, characterized in that said subset of said space dividers consist at least in part of materials within the group of Aramids.

75. A space division system in accordance with claim 74, characterized in that said subset of said space dividers are constructed at least in part of Kevlar®(D brand fiber.

76. A space division system in accordance with claim 1, characterized in that said plurality of partitions comprises at least a subset of said space dividers constructed at least in part of materials having substantial fire-resistant or fire-proof properties.

77. A space division system in accordance with claim 76, characterized in that said subset of said space dividers consist at least in part of materials within the group of Aramids.

78. A space division system in accordance with claim 77, characterized in that said subset of said space dividers are constructed at least in part of materials consisting of Nomex® brand fiber.

79. A space division system in accordance with claim 1, characterized in that said plurality of space dividers comprises at least a subset of said partitions consisting at least in part of materials comprising a blend of Kevlar® and Nomex® brand fibers.

80. A space division system in accordance with claim 1, characterized in that said system comprises means for securing at least a subset of said plurality of space dividers to a lower floor structure.

81. A space division system in accordance with claim 26, characterized in that said space division system further comprises switch means for controlling functional accessories associated with said partitions.

82. A space division system in accordance with claim 81, characterized in that said switch means comprise switches having differing spatial positions for generating "on" and "off" states.

83. A space division system in accordance with claim 81, characterized in that said switch means are electrically responsive to spatial signals so as to change between control states.

84. A space division system in accordance with claim 81, characterized in that said switch means comprise pressure switches.

85. A space division system in accordance with claim 81, characterized in that said switch means are responsive to signals indicative of motion within areas surrounding said switch means, for switching between control states.

86. A space division system in accordance with claim 81, characterized in that said switch means are responsive to radio frequency signals for switching between control states.

87. A space division system in accordance with claim 81, characterized in that said switch means are responsive to infrared signals for switching between control states.

88. A space division system in accordance with claim 61, characterized in that said at least one controlling device comprises at least one switch.

89. A space division system in accordance with claim 26, characterized in that said system further comprises means for generating and for sensing radio frequency identification signals.