

[54] **STRUCTURAL SLAB MEMBERS**

[72] Inventor: **Manuel Yeffal-Rueda, Mexico City, Mexico**

[73] Assignee: **Tridilosa International, Inc., Mexico D.F., Mexico**

[22] Filed: **July 20, 1970**

[21] Appl. No.: **56,260**

[52] U.S. Cl. **52/650, 52/648**

[51] Int. Cl. **E04c 3/09**

[58] Field of Search **52/650, 646, 648**

[56] **References Cited**

UNITED STATES PATENTS

| | | | |
|-----------|---------|--------------------|--------|
| 914,861 | 3/1909 | Muldoon | 52/648 |
| 1,273,344 | 7/1918 | Evers | 52/648 |
| 1,291,298 | 1/1919 | Walker | 52/648 |
| 1,349,868 | 8/1920 | Aherbury | 52/648 |
| 1,613,788 | 1/1927 | Dawson et al. | 52/648 |
| 2,140,283 | 12/1938 | Faber | 52/648 |
| 2,979,169 | 4/1961 | Yolles | 52/650 |
| 3,407,560 | 10/1968 | Baumann | 52/741 |
| 3,433,348 | 5/1969 | Papoyoti | 52/648 |

FOREIGN PATENTS OR APPLICATIONS

| | | | |
|-----------|--------|--------------|--------|
| 1,361,991 | 4/1964 | France | 52/650 |
|-----------|--------|--------------|--------|

812,464 7/1951 Germany.....52/650

Primary Examiner—Frank L. Abbott
Assistant Examiner—Leslie A. Braun
Attorney—Spencer & Kaye

[57] **ABSTRACT**

A structural slab element composed of two grid frames and a series of diagonal members extending between the two frames, with each diagonal member end being connected to an intersection point of a respective grid frame, wherein certain of the diagonal members and/or portions of the grid frames are removed to provide rectangular passages for conduits and the regions around the removed portions are strengthened by reinforcing members. Certain of the diagonal members are prolonged to extend out of the resulting slab perpendicular to the grid frames for reinforcing walls built on the slab. A basic slab of the type described has one side, corresponding to the location of a grid frame, embedded in a slab of concrete to provide a reusable, large-area, light weight construction mold form.

2 Claims, 12 Drawing Figures

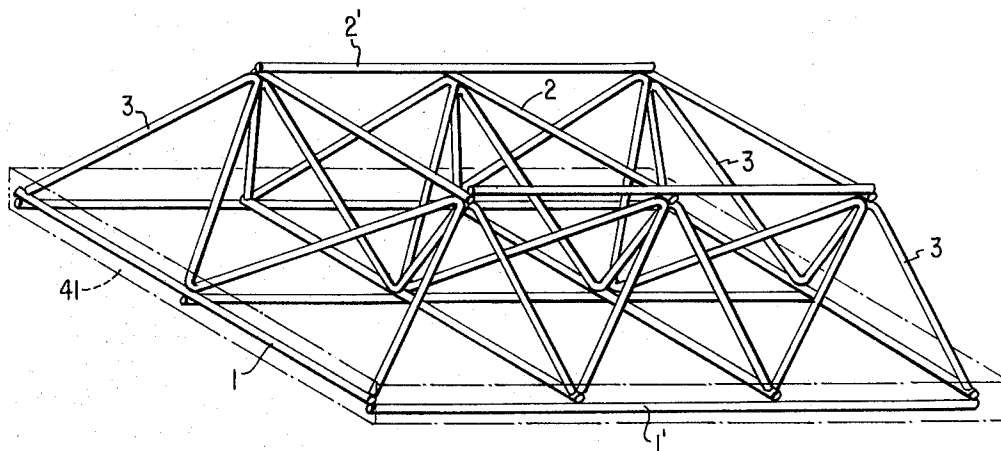

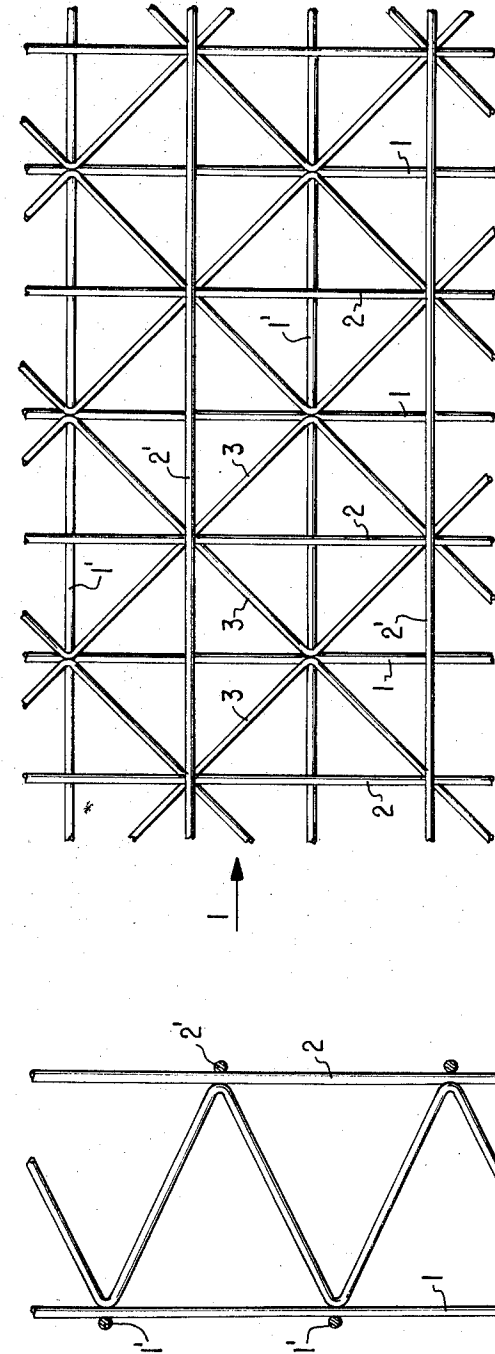

FIG. 1
(PRIOR ART)

FIG. 2
(PRIOR ART)

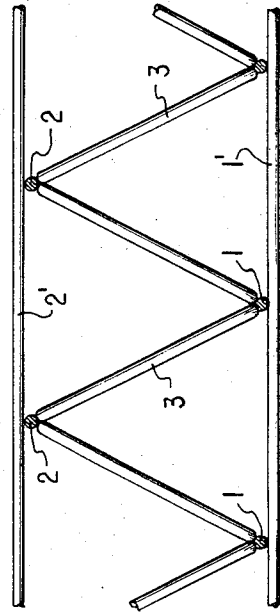

FIG. 3
(PRIOR ART)

INVENTOR
Manuel Yeffal-Rueda

BY *Spencer & Kays*
ATTORNEYS.

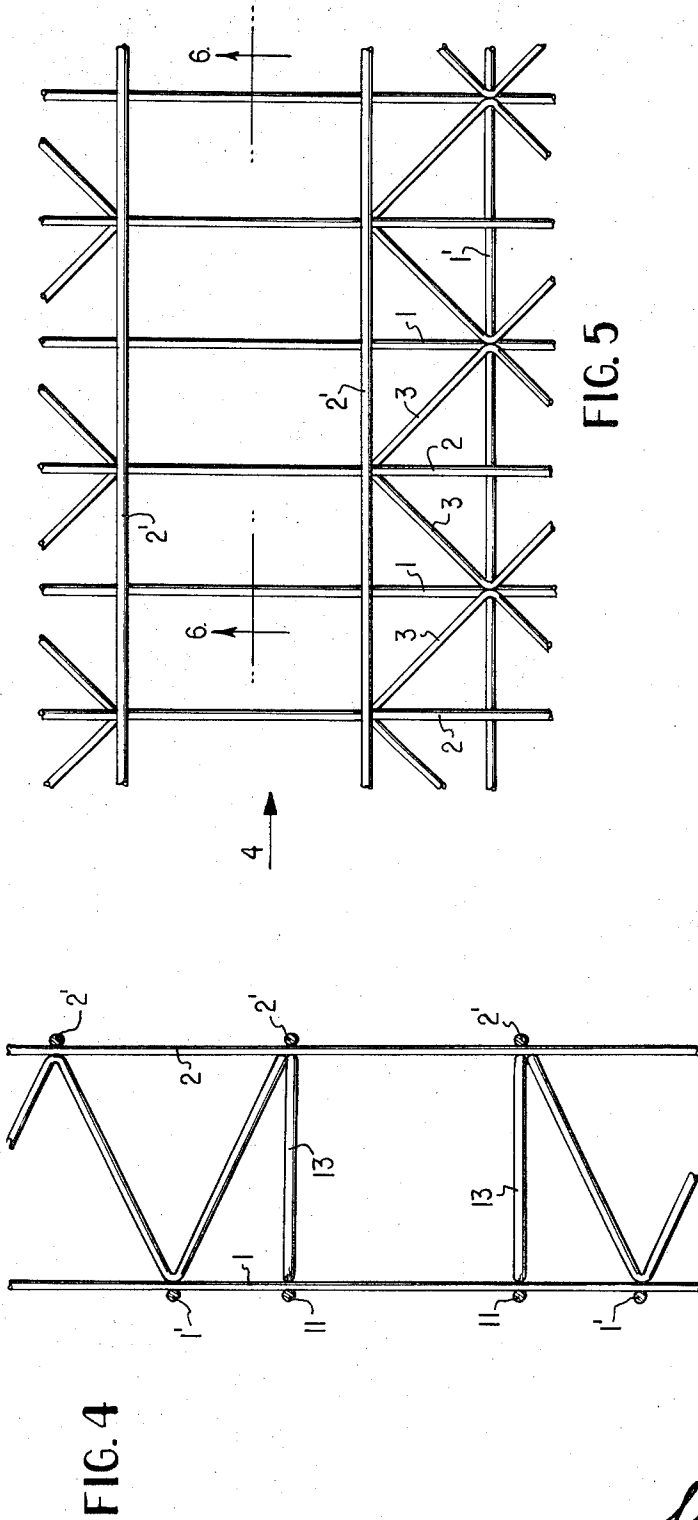

FIG. 4

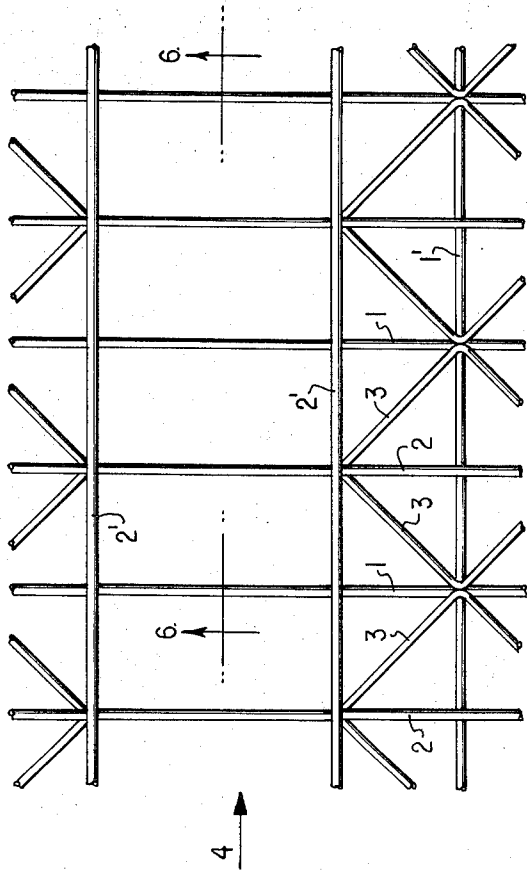

FIG. 5

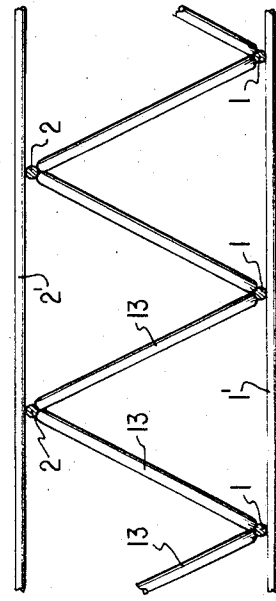

FIG. 6

INVENTOR
Manuel Yeffal-Rueda

BY *Spencer & Kaye*

ATTORNEYS.

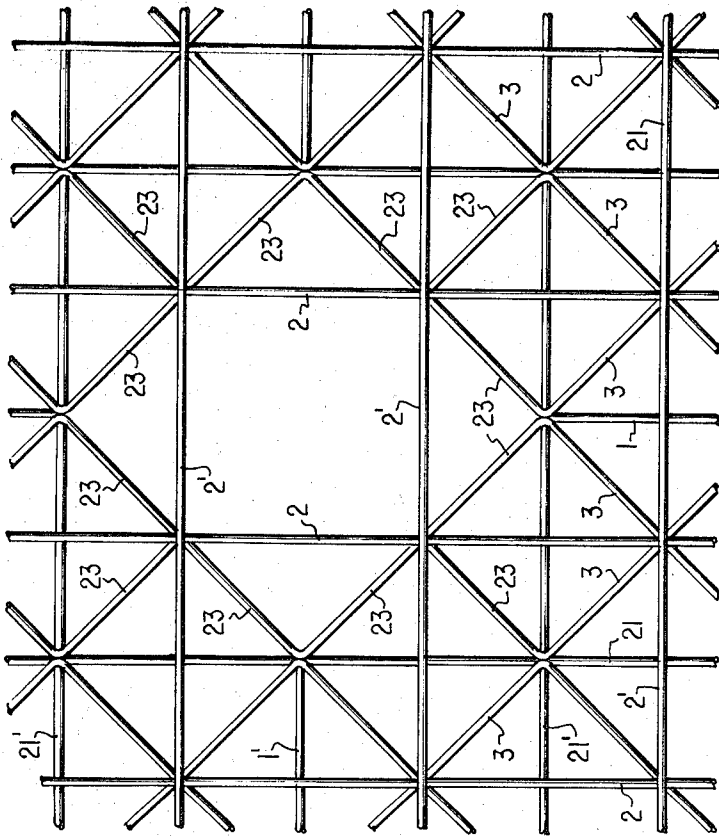

FIG. 9

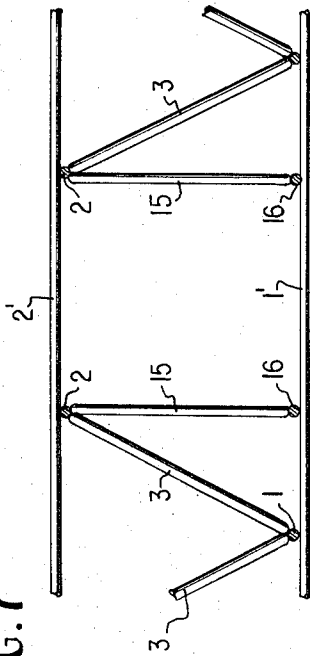

FIG. 7

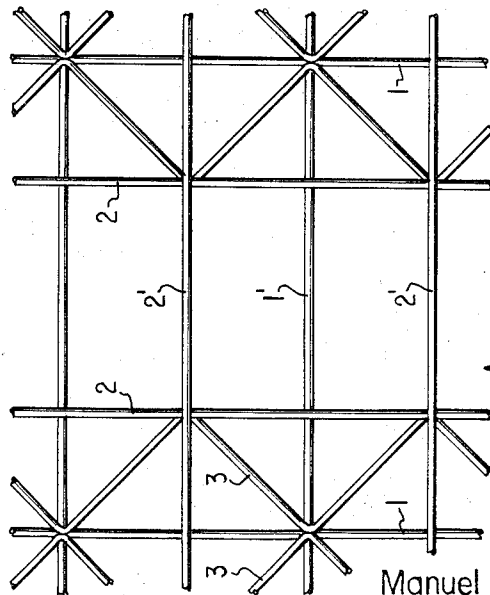

FIG. 8

INVENTOR
Manuel Yeffal-Rueda

BY *Spencer & Kaye*

ATTORNEYS.

FIG. 10

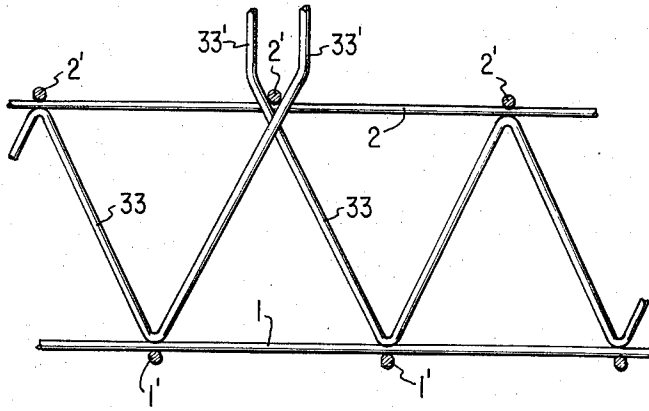

FIG. 11

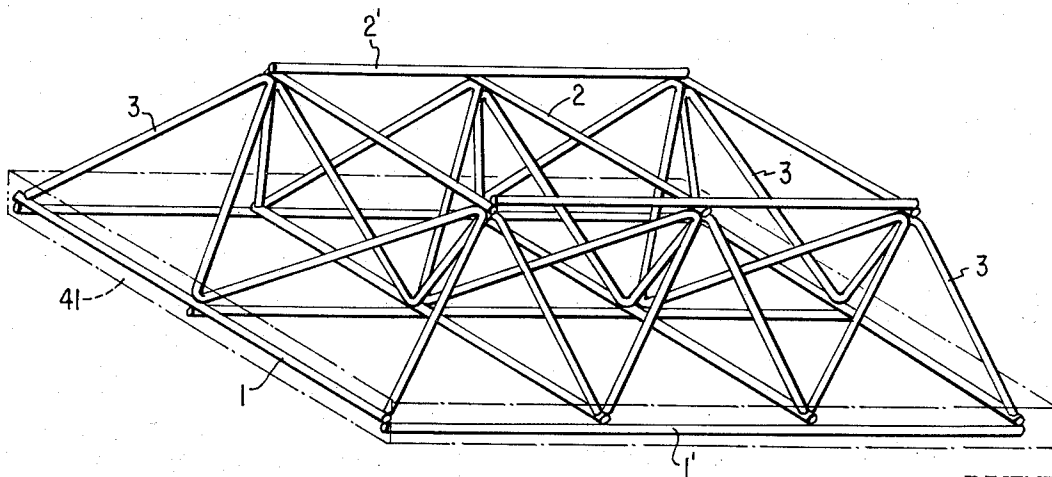
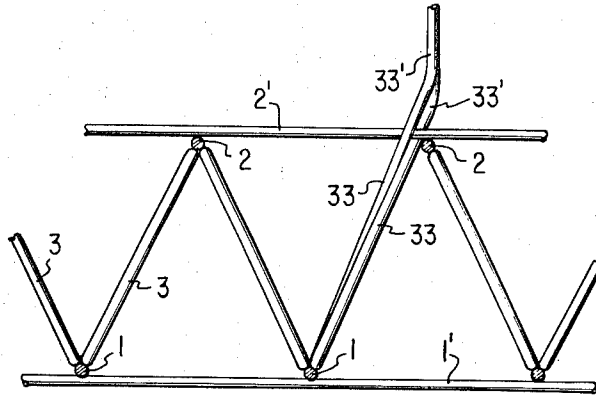

FIG. 12

INVENTOR
Manuel Yeffal-Rueda

BY *Spencer & Kaye*
ATTORNEYS.

STRUCTURAL SLAB MEMBERS

BACKGROUND OF THE INVENTION

The present invention relates to improvements in structural members composed of a framework, and particularly structural slabs of this type.

In the construction field, there is a continual demand for reducing the weight and fabrication cost of basic structural members capable of supporting the loads existing in buildings of all sizes and types, as well as bridges and the like. A notable contribution in this regard is disclosed in our Mexican Pat. No. 96,499, issued on Apr. 28, 1967.

That patent discloses structural slab members having an extremely low weight for a given load bearing capacity and capable of being fabricated in a rapid and simple manner either at the building side or in a fabrication installation. One basic embodiment of the slab structure disclosed in the patent is illustrated in FIGS. 1-3 of the drawings, FIGS. 1 and 3 being side views of the slab and FIG. 2 being a plan view thereof.

As is shown in FIGS. 1-3, the basic slab structure is constituted by a lower grid framework composed of parallel, longitudinal rods 1 and parallel transverse rods 1'. Rods 1' are disposed at right angles to rods 1 and are welded or otherwise attached thereto at each point of intersection of the grid. There is also provided a similar upper grid framework composed of parallel, longitudinal rods 2 and parallel transverse rods 2' welded together at each intersection point of the grid. The frameworks are arranged with respect to one another so that the intersection points of the lower framework are offset from the intersection points of the other framework, as is most clearly shown in FIG. 2. Between the two frameworks are disposed a series of bent rods 3, each forming a series of triangles. The rods 3 extend more or less in the same direction, roughly parallel to the rods 1 and 2. The rods 3 are disposed between the two frameworks so that successive vertices of each rod 3 are attached to intersection points of alternate frameworks. As a result, each straight leg of each rod 3 will extend diagonally between the frameworks.

In addition, each intersection point of each framework is connected to the apices of two adjacent rods 3.

The basic framework presents a high degree of rigidity and a low weight for a given load bearing capacity. In addition, since a great deal of free space exists between the framework, the resulting slab will, when the frameworks are covered with layers of concrete or other covering materials, contain a large volume of dead air which will serve as an effective sound and thermal insulator. In addition, the space between the frameworks can be employed for the passage of plumbing, electrical and heating the air conditioning units.

While the slabs illustrated in FIGS. 1-3 represent a valuable contribution to the art, the space between the tow frameworks is cut up by a regular array of diagonal rods which limit the maximum transverse dimensions of conduits which can pass through the slab. This is particularly troublesome when the building is to be provided with air conditioning, since air conditioning ducts normally have a relatively large rectangular cross section.

Furthermore, there is no simple and direct way to provide a reinforced connection between such slabs and vertical walls built thereon.

SUMMARY OF THE INVENTION

It is a primary object of the invention to overcome these drawbacks. Another object of the invention is to provide certain improvements in the above-described slabs.

Yet another object of the invention is to modify such slabs to permit the ready passage of large rectangular ducts. Still another object of the invention is to modify such slabs to provide for a direct reinforcing connection to overlying vertical walls.

A still further object of the invention is to produce mold forms from such slabs.

These and other objects according to the invention are achieved by eliminating certain diagonals and/or portions of one of the frameworks to permit the passage of large area rectangular ducts and by providing reinforced elements around the regions from which such elements have been eliminated. Objects according to the invention are also achieved by prolonging certain of the diagonals in a direction normal to the frameworks and into a region outside of the frameworks for reinforcing a wall disposed on the slab. Other objects according to the invention are achieved by forming a concrete plate, or slab, with one framework side of the slab embedded in the concrete so that the structural slab will support the concrete plate and the plate itself can serve as one side of a form in building construction.

BRIEF DESCRIPTION OF THE DRAWINGS

FIG. 1 is an elevational view of a prior art slab taken in the direction of the arrow 1 of FIG. 2.

FIG. 2 is a plan view of the slab of FIG. 1.

FIG. 3 is an elevational view of the slab taken in the direction of the arrow 3 of FIG. 2.

FIGS. 1-3 have already been described in detail.

FIG. 4 is an elevational view of one embodiment of the invention, taken in the direction of the arrow 4 of FIG. 5.

FIG. 5 is a plan view of the embodiment of FIG. 4.

FIG. 6 is a elevational view of the embodiment of FIG. 4 taken in the direction of the arrow 6 of FIG. 5.

FIG. 7 is an elevational view of another embodiment of the invention, taken in the direction of the arrow 7 of FIG. 8.

FIG. 8 is a plan view of the embodiment of FIG. 7.

FIG. 9 is a plan view of a further embodiment of the invention.

FIG. 10 is an elevational view of yet another embodiment of the invention.

FIG. 11 is an elevational view of the embodiment of FIG. 10, taken in a direction perpendicular to that of FIG. 10.

FIG. 12 is a perspective view of one further embodiment of the invention.

DESCRIPTION OF THE PREFERRED EMBODIMENTS

FIGS. 4-6 illustrate a first embodiment of the invention in which two adjacent rows of diagonal elements

are eliminated to provide a rectangular conduit channel in the direction of the arrow 4 of FIG. 5. In addition, the transverse rod of the lower framework to which the eliminated diagonals would be connected is also removed since, in the absence of connection diagonals, the contribution of this transverse rod to the strengthening of the slab would be minimal.

To compensate for the load supporting function which would be performed by the diagonals which have been eliminated, support members 13 are connected between the upper and lower frameworks and are disposed to define two opposed sides of the resulting conduit channel. The other sides of the channel are defined by the upper and lower frameworks. Support members 13 are oriented to be perpendicular to longitudinal framework rods 1 and 2 while being inclined to transverse rods 1' and 2', as is best illustrated in FIG. 6. The slab is also provided with additional transverse framework rods 11 forming part of the lower framework and disposed in line with the lower connection points of members 13. In contrast with rods 1', which are offset relative to rods 2', rods 11 are disposed to be in line with corresponding rods 2' of the upper framework.

These elements 11 and 13, which must be stronger and stiffer than the diagonal rods 3 and transverse rods 2', shall be constituted by structural shapes like angles, round or square steel pipes, or square rods. In some instances, when the dimensions of the duct are not too large, round steel rods of larger diameter could be used.

FIGS. 7 and 8 illustrate a modified version of the arrangement of FIGS. 4-6, wherein the rectangular channel is perpendicular to the channel of FIGS. 4-6. In this embodiment, two entire rods 3 are removed and replaced by zigzag rods 15 composed of straight portions which are perpendicular to framework rods 1' and 2' and inclined with respect to rods 1 and 2. In addition, one longitudinal rod of the lower grid framework is removed and in its place are provided two longitudinal rods 16. Each of the rods 16 is in line with the lower connecting points of a respective rod 15, and is also in line with a respective longitudinal rod 2 of the upper grid framework. Rods 15 and 16 thus take over the load supporting function of the eliminated rods 3 and the eliminated longitudinal rod of the lower framework. Rods 16 are connected to the rods 1' at their points of intersection. Rods 15 and 16 can be similar to the rods 11 and 13 of the embodiment of FIGS. 4-6.

FIG. 9 illustrates a further embodiment of the invention for the passage of a rectangular duct in a direction perpendicular to the planes of the upper and lower grid frameworks. In this embodiment, connecting members constituting portions of two adjacent diagonal rods 3 are removed, as are portions of a longitudinal rod 1 and a transverse rod 1' of the lower grid framework. This provides the desired rectangular channel for a vertical conduit.

In order to compensate for the load supporting function normally performed by the eliminated rod portions, the rods of the lower grid framework which are adjacent those rods having portions removed, are replaced by reinforced rods 21 and 21'. Similarly, portions of the diagonal rods surrounding the rectangular

channel are replaced by reinforced rod portions 23. The resulting assembly has substantially the same load supporting capability as a similar slab provided with the eliminated rod portions. The structure of this embodiment is essentially similar to the prior art structure in that the rods 21 and 21' and the diagonal rod portions 23 occupy the same positions as the rods and rod portions which they replace.

Elements 21, 21', and 23 must be stronger than the eliminated rod portions. Therefore, round reinforcing bars of larger diameter; and structural shapes like angles, angles, round or square steel pipes or square steel bars must be used.

Another feature of the present invention is illustrated in FIGS. 10 and 11. According to this feature, one zig-zag rod 3 is removed and replaced by two rods 33 each of which extends across a portion of the length of the slab. These rods 33 meet at one intersection point of the upper grid framework and from that point are extended upward to form extensions 33'. Rods 33 are disposed and connected in such a manner that extensions 33' will extend into the region to be occupied by a vertical wall supported by the slab. After the slab has been put in place in the building under construction, the vertical wall can be formed, from poured concrete for example, to enclose the extensions 33'. Thus, the wall will be reinforced by extensions 33', in addition to other reinforcements provided therein, and will automatically be securely connected to the slab itself, and hence to concrete flooring formed about the upper grid framework of the slab. If desired, the zig-zag rod 3 which is connected to the same point of intersection of the upper grid framework as the rods 33 could also be replaced by rods 33 having extensions 33' to provide four vertical extensions for reinforcing a vertical wall at that point. For providing reinforcing extensions at several points across the length of a slab, a plurality of rods 33 each providing a vertical extension at each end could be substituted for one or several of the zig-zag rods 3.

FIG. 12 illustrates another feature of the present invention according to which a basic slab unit composed of an upper grid framework, a lower grid framework and zig-zag support rods 3 has its lower framework 1,1' embedded in a concrete plate 41, represented in outline by broken lines to permit the entire slab to be visible, to produce one wall of a construction mold form. Such an arrangement can be fabricated by first assembling the structural slab, positioning the slab in a concrete mold, for example of the extrusion machine, vibrating table or prestressed bed type, so that the lower framework is in the region to be filled with concrete, and then forming the concrete plate 41.

The dimensions of such a form can be selected according to the size of the available transport vehicles and the facilities available for handling the form at the building site.

Such a mold form has certain distinct advantages in that it can be employed with a minimum of shoring and the concrete plate can be made to cover a larger contact surface, and to be flatter, than conventional construction mold forms. The mold form illustrated in FIG. 12 has the further advantage that it is easily reusable.

While all of the embodiments according to the invention have been illustrated in the drawings as being com-

5

posed of cylindrical rods, it should be appreciated that basic elements having other configurations can also be employed. For example, the slabs could be built up from angle irons, channel pieces, rectangular rods, or even wooden bars.

In addition, in the embodiments of FIGS. 4-6 and 7-8, the diagonals could be removed only along a portion of the slab to form a rectangular channel which ends within the slab when a duct is to extend only to a corresponding point of the slab and is then to pass through one of the grid frameworks.

It will be understood that the above description of the present invention is susceptible to various modifications, changes and adaptations, and the same are intended to be comprehended within the meaning and range of equivalents of the appended claims.

I claim:

1. In a structural member comprising: first and second spaced grid frameworks each composed of two mutually perpendicular sets of parallel, elongated framework elements with the elements of one set connected to the elements of the other set at the points of intersection of the two sets; and a plurality of elongated diagonal elements each having one end connected to a point of intersection of one framework and its other end connected to an adjacent point of intersection of the other framework, each diagonal element being inclined with respect to both sets of framework elements of each framework so that the points of intersection of one framework are offset, with respect to the plane of each framework, from the points of intersection of the other framework in the directions of both sets of framework elements and each set of framework elements of one framework is oriented in the same direction as a respective set of framework elements of the other framework, there being two diagonal elements connected to each point of intersection of each said framework, the improvement wherein the diagonal elements connected to at least one said point of intersection comprise extensions extending from the ends of said diagonal elements which are connected to that point of intersection and projecting out of said structural member and perpendicular thereto for connecting said elements to a body of material formed around said extensions, wherein said member is made free of elements in a three-dimensional region to define a clear channel extending at least partially through said member and having a square cross section one dimension of which coincides with the area enclosed by two adjacent framework elements of one set of said first framework, said channel extending parallel to one set of framework elements of each said framework, and wherein said member further comprises two reinforcing framework elements connected on said second framework and disposed parallel to, and in line with, said two adjacent framework elements of said first framework to define therewith the corners of said

6

channel, and reinforcing diagonal elements, each connected between one of said reinforcing framework elements, at a point of intersection of that framework element with a framework element of the other set of said second framework and that one of said adjacent elements which is at the same side of said channel, at a point of intersection of said first framework, each said reinforcing diagonal element being parallel to a plane defining one side of said channel and being inclined to said reinforcing framework elements, said reinforcing elements have a greater load bearing capacity than the other elements of said member.

2. In a structural member comprising: first and second spaced grid frameworks each composed of two mutually perpendicular sets of parallel, elongated framework elements with the elements of one set connected to the elements of the other set at the points of intersection of the two sets; and a plurality of elongated diagonal elements each having one end connected to a point of intersection of one framework and its other end connected to an adjacent point of intersection of the other framework, each diagonal element being inclined with respect to both sets of framework elements of each framework so that the points of intersection of one framework are offset, with respect to the plane of each framework, from the points of intersection of the other framework in the directions of both sets of framework elements and each set of framework elements of one framework is oriented in the same direction as a respective set of framework elements of the other framework, there being two diagonal elements connected to each point of intersection of each said framework, the improvement wherein the diagonal elements connected to at least one said point of intersection comprise extensions extending from the ends of said diagonal elements which are connected to that point of intersection and projecting out of said structural member and perpendicular thereto for connecting said elements to a body of material formed around said extensions, wherein said member is made free of elements in a three-dimensional region to define a clear channel extending at least partially through said member and having a square cross section one dimension of which coincides with the area enclosed by two adjacent framework elements of one set of said first framework, and wherein said channel extends perpendicular to said frameworks, and the two mutually perpendicular framework elements of said second framework whose projections intersect in the region defining said channel are each constituted by two partial elements disposed wholly outside of said region, said framework elements of said first framework and said diagonal elements adjacent said region are constituted by reinforced elements having a greater load bearing capacity than the other elements of said member.

* * * * *