



- (51) International Patent Classification:
A61N 5/10 (2006.01) *G01R 33/48* (2006.01)
G01R 33/387 (2006.01)
- (21) International Application Number:
PCT/US2014/023556
- (22) International Filing Date:
11 March 2014 (11.03.2014)
- (25) Filing Language: English
- (26) Publication Language: English
- (30) Priority Data:
13/801,680 13 March 2013 (13.03.2013) US
- (71) Applicant: **VIEWRAY INCORPORATED** [US/US]; 2 Thermo Fisher Way, Oakwood Village, OH 44146 (US).
- (72) Inventors: **SHVARTSMAN, Shmaryu, M.**; 2 Thermo Fisher Way, Oakwood Village, OH 44146 (US). **DEMPSEY, James, F.**; 2 Thermo Fisher Way, Oakwood Village, OH 44146 (US). **NIKOLY, David**; 2 Thermo Fisher Way, Oakwood Village, OH 44146 (US).

(74) Agents: **VANLOY, Michael, D.** et al.; Mintz Levin Cohn Ferris Glovsky and Popeo, P.C., 3580 Carmel Mountain Road, Suite 300, San Diego, CA 92130-6768 (US).

(81) Designated States (unless otherwise indicated, for every kind of national protection available): AE, AG, AL, AM, AO, AT, AU, AZ, BA, BB, BG, BH, BN, BR, BW, BY, BZ, CA, CH, CL, CN, CO, CR, CU, CZ, DE, DK, DM, DO, DZ, EC, EE, EG, ES, FI, GB, GD, GE, GH, GM, GT, HN, HR, HU, ID, IL, IN, IR, IS, JP, KE, KG, KN, KP, KR, KZ, LA, LC, LK, LR, LS, LT, LU, LY, MA, MD, ME, MG, MK, MN, MW, MX, MY, MZ, NA, NG, NI, NO, NZ, OM, PA, PE, PG, PH, PL, PT, QA, RO, RS, RU, RW, SA, SC, SD, SE, SG, SK, SL, SM, ST, SV, SY, TH, TJ, TM, TN, TR, TT, TZ, UA, UG, US, UZ, VC, VN, ZA, ZM, ZW.

(84) Designated States (unless otherwise indicated, for every kind of regional protection available): ARIPO (BW, GH, GM, KE, LR, LS, MW, MZ, NA, RW, SD, SL, SZ, TZ, UG, ZM, ZW), Eurasian (AM, AZ, BY, KG, KZ, RU, TJ, TM), European (AL, AT, BE, BG, CH, CY, CZ, DE, DK, EE, ES, FI, FR, GB, GR, HR, HU, IE, IS, IT, LT, LU, LV, MC, MK, MT, NL, NO, PL, PT, RO, RS, SE, SI, SK, SM,

[Continued on next page]

(54) Title: SYSTEMS AND METHODS FOR RADIOTHERAPY WITH MAGNETIC RESONANCE IMAGING

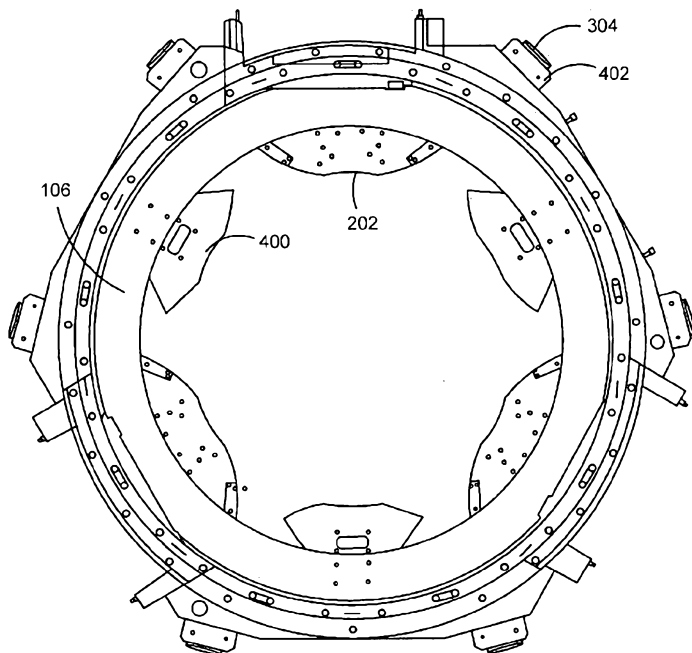

FIG. 4

(57) Abstract: Systems and methods for delivery of radiotherapy in conjunction with magnetic resonance imaging in which various conductors, shields and shims may be used to solve issues occurring when radiation therapy equipment is placed in the vicinity of an magnetic resonance imaging system.



TR), OAPI (BF, BJ, CF, CG, CI, CM, GA, GN, GQ, GW, KM, ML, MR, NE, SN, TD, TG). **Published:**

— with international search report (Art. 21(3))

**SYSTEMS AND METHODS FOR RADIOTHERAPY WITH MAGNETIC
RESONANCE IMAGING**

CROSS-REFERENCE TO RELATED APPLICATION

[0001] The present PCT application claims priority to U.S. Pat. App. Ser. No. 13/801,680, filed March 13, 2013, entitled “Systems and Methods for Radiotherapy With Magnetic Resonance Imaging,” the filing date and full disclosure of which is incorporated herein by reference.

TECHNICAL FIELD

[0002] The present disclosure relates to systems and methods for the delivery of radiotherapy in conjunction with magnetic resonance imaging.

BACKGROUND

[0003] It is desirable to combine radiation therapy with repetitive real-time imaging using a magnetic resonance imaging system (MRI) in order to better locate and treat therapy targets while sparing nearby healthy tissue. While MRIs and radiation treatment systems such as linear accelerators or radioisotope beams have operated separately from one another for quite some time, combining the two technologies presents many significant technological challenges. Examples of such challenges include the magnetic fields and eddy currents generated in ferromagnetic and conductive radiotherapy equipment through the MRI’s main and gradient magnets, both of which can destroy an MRI’s ability to provide quality images.

SUMMARY

[0004] Disclosed herein are systems and methods for combining radiotherapy with magnetic resonance imaging.

[0005] In one embodiment, a system may include a magnetic resonance imaging system, a gantry, one or more radiation therapy heads fixed to the gantry, one or more collimating devices associated with the one or more heads, including a plurality of leaves, one or more leaf drive motors for moving the leaves, the one or more leaf drive motors including one or more position sensors, and a magnetic shield substantially surrounding the one or more position sensors, one or more permanent magnets adjacent the one or more leaf drive motors, the one or more permanent magnets oriented so as to counteract the MRI's main magnetic field, and one or more additional conductive elements disposed around the gantry in a substantially symmetrical manner. The one or more additional conductive elements may have a shape, volume or material permeability designed to substantially match the shape, volume or material permeability of the collimating devices. In addition, the one or more additional conductive elements may be substantially similar to the outer housings of the collimating devices. In one embodiment, only one radiation therapy head is fixed to the gantry and only one collimating device is associated with the one radiation therapy head and the one or more additional conductive elements is a single conductive element extending substantially around the portion of the gantry not occupied by the one collimating device. Furthermore, the magnetic shield may be made of steel and may be cylindrical in shape.

[0006] In another embodiment, a system may include a magnetic resonance imaging system, a gantry, one or more radiation therapy heads fixed to the gantry, one or

more collimating devices associated with the one or more heads and one or more additional conductive elements disposed around the gantry in a substantially symmetrical manner. The one or more additional conductive elements may be additional collimating devices or may be substantially similar to the outer housings of the collimating devices. In addition, the one or more additional conductive elements may have a shape, volume or material permeability designed to substantially match the shape, volume or material permeability of the collimating devices. In another embodiment, the one or more radiation therapy heads may be three radioisotopic sources, and the one or more additional conductive elements may be three conductors substantially similar to the outer housings of the collimating devices. In yet another embodiment, only one radiation therapy head is fixed to the gantry and only one collimating device is associated with the one radiation therapy head and the one or more additional conductive elements comprises a single conductive element extending substantially around the portion of the gantry not occupied by the one collimating device.

[0007] In still another embodiment, the system may include a magnetic resonance imaging system, a gantry, one or more radiation therapy heads fixed to the gantry, one or more collimating devices associated with the one or more heads, including a plurality of leaves, one or more leaf drive motors for moving the leaves, the one or more leaf drive motors including one or more position sensors and a magnetic shield substantially surrounding the one or more position sensors. The magnetic shield may have a cylindrical shape and may be made out of ferromagnetic material, such as steel.

[0008] In another embodiment, the system may include a magnetic resonance imaging system, a gantry, one or more radiation therapy heads fixed to the gantry, one or

more collimating devices associated with the one or more heads, including a plurality of leaves, one or more leaf drive motors for moving the leaves and one or more permanent magnets adjacent the one or more leaf drive motors, the one or more permanent magnets oriented so as to counteract the MRI's main magnetic field. Permanent magnets may be placed on either side of the one or more leaf drive motors and may be made from Neodymium.

[0009] These and other features, aspects, and advantages of the present disclosure will become better understood with reference to the following description and claims.

BRIEF DESCRIPTION OF DRAWINGS

[0010] Features, aspects, and implementations of the disclosure are described in conjunction with the attached drawings, in which:

[0011] FIG. 1 is a simplified diagram illustrating aspects of a radiation therapy device operating in conjunction with a magnetic resonance imaging system consistent with implementations of the current subject matter;

[0012] FIG. 2 is a simplified diagram illustrating an example of a treatment system consistent with implementations of the current subject matter;

[0013] FIG. 3 illustrates an exemplary collimating device, specifically a multi-leaf collimator;

[0014] FIG. 4 illustrates one example of an arrangement of conductive elements consistent with implementations of the current subject matter;

[0015] FIG. 5A is a simplified diagram illustrating a leaf motor combined with an example magnetic shield consistent with implementations of the current subject matter;

[0016] FIG. 5B is a simplified representation of the effect of a magnetic shield on an MRI's main magnetic field;

[0017] FIG. 6 is a simplified illustration of permanent magnets being placed adjacent a bank of leaf motors consistent with implementations of the current subject matter;

[0018] FIG. 7 illustrates an exemplary magnetic orientation of permanent magnets with respect to an MRI's main magnetic field consistent with implementations of the current subject matter; and

[0019] FIG. 8 shows a process flow chart illustrating features of a method consistent with implementations of the current subject matter.

DETAILED DESCRIPTION

[0020] Disclosed herein are systems and methods for combining radiotherapy with magnetic resonance imaging. FIG. 1 is a simplified schematic view of an implementation of a radiation therapy system including a radiation therapy head 104 mounted on a gantry 106, which can rotate to different positions to enable radiation delivery from different angles. The exemplary system depicted in FIG. 1 also includes an MRI 102, which may be used for real-time imaging during radiation therapy and maybe of the split or open type of MRI as shown. Radiation therapy head 104 can be used to direct a treatment beam at a target within patient 108 lying on couch 110.

[0021] FIG. 2 depicts an example of a radiation therapy system that may be used with the disclosed systems and methods. The example depicted includes three radioisotopic sources 200, such as Cobalt-60, mounted on gantry 106, directing three radiotherapy beams at patient 108. While this example utilizes radioisotopic beams, this disclosure contemplates and is applicable to other radiotherapy beam types such as linear accelerators, proton beams, etc. In addition, while the example of FIG. 2 shows three radiotherapy heads spaced in an equidistant manner around the gantry, the systems and methods disclosed herein apply to any number of radiotherapy heads (i.e., one or more).

[0022] FIG. 2 also depicts collimating devices 202 attached to gantry 106 and associated with each of the sources 200. Collimating devices 202 may, for example, be multi-leaf collimators (MLCs), as shown in further detail in FIG. 3. MLCs typically have two banks of opposing pairs of leaves 302, which move independently and can open to form apertures of various shapes and sizes. The number of leaves 302 can vary. Leaves 302 may be made of tungsten or any suitable material or materials for blocking radiation. MLCs may also employ a tongue and groove arrangement on the long sides and front of the leaves 302 to limit interleaf radiation leakage and can be configured for interdigitiation of the leaves 302 in the closed position.

[0023] Each leaf 302 of each bank of leaves may be capable of independent motion and may be driven by leaf motors 304 through connecting rods 306. An MLC control system can control the two opposing banks of leaves 302 to independently position the edge of each leaf 302 to a specified location in order to block a radiation beam and form a field size of a specific shape.

[0024] The MLC leaves 302, motors 304, and other components may be supported by housing 308 that then attaches to gantry 106. Housing 308 may be, for example, made from aluminum.

[0025] FIG. 4 depicts an exemplary gantry 106 layout for the example radiation therapy system depicted in FIG. 2 having three radioisotopic sources 200 along with three corresponding collimating devices 202. The embodiment of FIG. 4 further includes additional conductive elements 400. Conductive elements 400 may be made of a single material or combine multiple materials. The conductive elements preferably have a shape, volume and material permeability (i.e., the degree of magnetization that a material obtains in response to an applied magnetic field) designed to substantially match those of collimating devices 202 in such respects as are pertinent to the generation of eddy currents during energizing of the MRI's gradient coils. For example, in the embodiment depicted in FIG. 4, conductive elements 400 could comprise identical multi-leaf collimators.

[0026] Because including additional sets of identical multi-leaf collimators would be expensive, and because eddy currents are primarily generated in the outer housings 308 of collimating devices 202, conductive elements 400 may merely be substantially similar to the housings 308 of collimating devices 202. For example, conductive elements 400 may be pairs of aluminum multi-leaf collimator housings. Alternatively, conductive elements 400 may be other shapes or other materials that substantially mimic the eddy current properties of the collimating devices 202 or housings 308.

[0027] Conductive elements 400 are preferably placed in positions around gantry 106 to create a substantially symmetrical pattern, as depicted in FIG. 4. The positions and number of conductive elements 400 may vary, but the resulting arrangement is preferably symmetrical about the circumference of gantry 106. As noted above, this disclosure contemplates and is applicable to any type of radiotherapy device. In the case where there is a single radiation therapy head, for example, a linear accelerator, the same principles for the additional conductive elements 400 described above apply. In one example, there may be five conductive elements 400 substantially equally spaced around gantry 106, along with the single collimating device 202. In another example, a single conductive element 400 may extend around substantially the entire portion of the circumference of gantry 106 not occupied by collimating device 202. While a number of examples have been given for the design and layout of conductive elements 400, any design and layout meeting the spirit of this disclosure is contemplated.

[0028] Leaf motors 304 associated with collimating devices 202, typically include one or more position sensors 500 capable of determining the position of associated leaves 302, as shown in FIG. 5A. For example, position sensor 500 may be a Hall effect encoder, which is capable of determining how many times a motor has rotated. A preferred embodiment includes magnetic shields 502 substantially surrounding sensors 500. Magnetic shield 502 is preferably cylindrically shaped and made of a ferromagnetic material, in one example. One such ferromagnetic material may be steel, but other materials and shapes suitable for magnetic shielding can be used. In one embodiment, the wall thickness of a steel cylinder is in the range of 1.5-2.0 mm and reduces the magnetic field within the shield to below 140 Gauss. In one preferred

embodiment, the wall thickness of the steel cylinders 1.6 mm. FIG. 5B demonstrates how magnetic shield 502 can decrease the magnetic field to which sensor 500 is subjected from that of the main magnet magnetic field 504 to a reduced magnetic field 506 observed within the shield.

[0029] Position sensors 500 are preferably oriented within magnetic shield 502 so as to be in the location at which the magnetic field is weakest, as shown in FIG. 5B as the top and bottom of magnetic shield 502.

[0030] In one embodiment of the disclosure, permanent magnets 600 may be placed adjacent to the bank of motors 304, as shown in FIG. 6. Permanent magnets 600 may be held in place by housings 402 and, in one embodiment, may be made from Neodymium (NdFeB). The polar orientation of the permanent magnets 600 should be such that it counteracts the MRI's main magnetic field and the magnetic field induced in the motors and motor shields 304. FIG. 7 illustrates this orientation of permanent magnets 600 amidst the MRI's main magnetic field 700, showing the north-south polarity of permanent magnets 702 opposing the main magnet's magnetic field 700.

[0031] One embodiment of the disclosure contemplates one permanent magnet being placed on either side of the bank of motors 304 as shown in FIG. 6. However, any number and arrangement of properly oriented permanent magnets 600 may be used that results in substantial cancellation of the magnetic field induced in motor shields 304 and other ferromagnetic materials in the area (for example, the motor housings). As an alternative to permanent magnets 600, active windings could be used as well. The canceling effect of the magnet design's strengths, field orientations, and locations can be determined utilizing modeling software such as FARADAY, available

from Integrated Engineering Software, or any other appropriate software such as VectorField, for example, and with further analysis of results potentially being performed in a program such as MATLAB or any other appropriate software such as FORTRAN, for example.

[0032] In one embodiment of the systems and methods of the disclosure, the leaf motors 304 may also be oriented so that the permanent magnets stators within them either cancel out the group of motors' magnetic field, or may alternatively be oriented in a manner that causes the group's magnetic field to be known or predictable.

[0033] While placing permanent magnets 600 adjacent the banks of leaf motors 304 substantially improves field homogeneity, the main magnetic field can be further improved, and the effect of radiation therapy equipment on MRI 102 further decreased. In addition to the leaf motors 304, magnetic shields 502, motor housings, stators within the motors and the like, the collimating devices 202 contain leaves 302 that may also have ferromagnetic properties. For example, leaves 302 may be made from a material such as tungsten, which has a relatively low permeability of approximately 1.03, but which, due to the large volume of the leaves, may also have a significant effect on the MRI's magnetic field. Magnetic field homogeneity may be in further improved, for example, by placing additional permanent magnet shims within the system. For example, in the embodiment depicted in FIG. 4 and discussed above, additional permanent magnets may be placed on the three conductive elements 400. While such location has proven beneficial for this embodiment, there are numerous other locations that would prove beneficial to field homogeneity, as can be determined using modeling software such as FARADAY or any other appropriate software such as VectorField, for example. Other

locations could include, for example, on the collimating devices 202 themselves. In addition, active windings could be used in place of, or in conjunction with, the permanent magnets. Finally, standard ferromagnetic shims may be used.

[0034] FIG. 8 shows a process flow chart 800 illustrating features of a method consistent with implementations of the current subject matter. At 802, images of a subject are captured using a magnetic resonance imaging system. At least one radiation beam is delivered to the subject from one or more radiation therapy heads fixed to a gantry at 804. A radiation delivery field size of a specific shape is formed at 806 by partially blocking the radiation beam with a collimating device. The collimating device includes a position sensor and a motor. The position sensor determines how many times the motor is rotated. The method can optionally include either or both of counteracting a magnetic field to which the position sensor is subjected at 810 and mimicking an eddy current property of at least one of the collimating device and a housing of the collimating device at 812. The counteracting of the magnetic field can include shielding the position sensor with a magnetic shield to achieve a reduced magnetic field relative a main magnet magnetic field of the magnetic resonance imaging system. The mimicking of the eddy current can include disposing additional conductive elements symmetrically about the gantry.

[0035] The subject matter described herein can be embodied in systems, apparatus, methods, and/or articles depending on the desired configuration. The implementations set forth in the foregoing description do not represent all implementations consistent with the subject matter described herein. Instead, they are merely some examples consistent with aspects related to the described subject matter.

While various implementations in accordance with the disclosed principles have been described above, it should be understood that they have been presented by way of example only, and are not limiting. Thus, the breadth and scope of the invention(s) should not be limited by any of the above-described exemplary implementations, but should be defined only in accordance with the claims and their equivalents issuing from this disclosure. The present disclosure contemplates that the calculations disclosed in the implementations herein may be performed in a number of ways, applying the same concepts taught herein, and that such calculations are equivalent to the implementations disclosed. Furthermore, the above described advantages are not intended to limit the application of any issued claims to processes and structures accomplishing any or all of the advantages.

[0036] Additionally, section headings shall not limit or characterize the invention(s) set out in any claims that may issue from this disclosure. Specifically, and by way of example, although the headings refer to a “Technical Field,” such claims should not be limited by the language chosen under this heading to describe the so-called technical field. Further, the description of a technology in the “Background” is not to be construed as an admission that technology is prior art to any invention(s) in this disclosure. Neither is the “Summary” to be considered as a characterization of the invention(s) set forth in issued claims. Furthermore, any reference to this disclosure in general or use of the word “invention” in the singular is not intended to imply any limitation on the scope of the claims set forth below. Multiple inventions may be set forth according to the limitations of the multiple claims issuing from this disclosure, and

such claims accordingly define the invention(s), and their equivalents, that are protected thereby.

[0037] Although a few variations have been described in detail above, other modifications or additions are possible. In particular, further features and/or variations can be provided in addition to those set forth herein. For example, the implementations described above can be directed to various combinations and subcombinations of the disclosed features and/or combinations and subcombinations of several further features disclosed above. In addition, the logic flows depicted in the accompanying figures and/or described herein do not necessarily require the particular order shown, or sequential order, to achieve desirable results.

[0038] In the descriptions above and in the claims, phrases such as “at least one of” or “one or more of” may occur followed by a conjunctive list of elements or features. The term “and/or” may also occur in a list of two or more elements or features. Unless otherwise implicitly or explicitly contradicted by the context in which it used, such a phrase is intended to mean any of the listed elements or features individually or any of the recited elements or features in combination with any of the other recited elements or features. For example, the phrases “at least one of A and B;” “one or more of A and B;” and “A and/or B” are each intended to mean “A alone, B alone, or A and B together.” A similar interpretation is also intended for lists including three or more items. For example, the phrases “at least one of A, B, and C;” “one or more of A, B, and C;” and “A, B, and/or C” are each intended to mean “A alone, B alone, C alone, A and B together, A and C together, B and C together, or A and B and C together.”

[0039] Use of the term “based on,” above and in the claims is intended to mean, “based at least in part on,” such that an unrecited feature or element is also permissible.

WHAT IS CLAIMED IS:

1. A system comprising:
 - a magnetic resonance imaging system;
 - a gantry;
 - one or more radiation therapy heads fixed to the gantry;
 - one or more collimating devices associated with the one or more heads, including a plurality of leaves;
 - one or more leaf drive motors for moving the leaves, the one or more leaf drive motors including one or more position sensors, and a magnetic shield substantially surrounding the one or more position sensors;
 - one or more permanent magnets adjacent the one or more leaf drive motors, the one or more permanent magnets oriented so as to counteract the MRI's main magnetic field; and
 - one or more additional conductive elements disposed around the gantry in a substantially symmetrical manner.
2. The system of claim 1, wherein the one or more collimating devices have a first shape, a first volume, and a first material permeability, and the one or more additional conductive elements have a second shape, a second volume, or a second material permeability designed to substantially match the first shape, the first volume, or the first material permeability of the one or more collimating devices.

3. The system of any of claims 1 to 2, wherein the one or more collimating devices include outer housings and the one or more additional conductive elements are substantially similar to the outer housings of the collimating devices.

4. The system of any of claims 1 to 3, wherein only one radiation therapy head is fixed to the gantry and only one collimating device is associated with the one radiation therapy head, and the one or more additional conductive elements comprises a single conductive element extending substantially around the portion of the gantry not occupied by the one collimating device.

5. The system of any of claims 1 to 4, wherein the magnetic shield comprises steel and has a cylindrical shape.

6. A system comprising:
a magnetic resonance imaging system;
a gantry;
one or more radiation therapy heads fixed to the gantry;
one or more collimating devices associated with the one or more heads; and,
one or more additional conductive elements disposed around the gantry in a substantially symmetrical manner.

7. The system of claim 6 wherein the one or more additional conductive elements comprise additional collimating devices.

8. The system of any of claims 6 to 7, wherein the one or more collimating devices include outer housings and the one or more additional conductive elements are substantially similar to the outer housings of the collimating devices.

9. The system of any of claims 6 to 8, wherein the one or more collimating devices have a first shape, a first volume, and a first material permeability, and the one or more additional conductive elements have a second shape, a second volume, or a second material permeability designed to substantially match the first shape, the first volume, or the first material permeability of the one or more collimating devices.

10. The system of any of claims 6 to 9, wherein the one or more radiation therapy heads comprises three radioisotopic sources, and the one or more additional conductive elements comprise three conductors substantially similar to the outer housings of the collimating devices.

11. The system of any of claims 6 to 10, wherein only one radiation therapy head is fixed to the gantry and only one collimating device is associated with the one radiation therapy head, and the one or more additional conductive elements comprises a single conductive element extending substantially around the portion of the gantry not occupied by the one collimating device.

12. A system comprising:
a magnetic resonance imaging system;
a gantry;
one or more radiation therapy heads fixed to the gantry;

one or more collimating devices associated with the one or more heads, including a plurality of leaves;

one or more leaf drive motors for moving the leaves, the one or more leaf drive motors including one or more position sensors and a magnetic shield substantially surrounding the one or more position sensors.

13. The system of claim 12 wherein the magnetic shield has a cylindrical shape.

14. The system of any of claims 12 to 13 wherein the magnetic shield comprises a ferromagnetic material.

15. The system of claim 14 wherein the ferromagnetic material comprises steel.

16. A system comprising:
a magnetic resonance imaging system;
a gantry;
one or more radiation therapy heads fixed to the gantry;
one or more collimating devices associated with the one or more heads, including a plurality of leaves;
one or more leaf drive motors for moving the leaves; and,
one or more permanent magnets adjacent the one or more leaf drive motors, the one or more permanent magnets oriented so as to counteract the MRI's main magnetic field.

17. The system of claim 16, further comprising a permanent magnet disposed on either side of the one or more leaf drive motors.

18. The system of claim 17 wherein the permanent magnet comprises Neodymium.

19. A method, comprising:
capturing images of a subject using a magnetic resonance imaging system;
delivering at least one radiation beam to the subject from one or more radiation therapy heads fixed to a gantry;
forming a radiation delivery field size of a specific shape by partially blocking the radiation beam with a collimating device, the collimating device comprising a position sensor and a motor, the position sensor determining how many times the motor is rotated;
and
counteracting a magnetic field to which the position sensor is subjected and/or mimicking an eddy current property of at least one of the collimating device and a housing of the collimating device.

20. A method of claim 19, wherein the counteracting of the magnetic field comprises shielding the position sensor with a magnetic shield to achieve a reduced magnetic field relative a main magnet magnetic field of the magnetic resonance imaging system.

21. The method of any of claims 19 to 20, wherein the mimicking of the eddy current comprises disposing additional conductive elements symmetrically about the gantry.

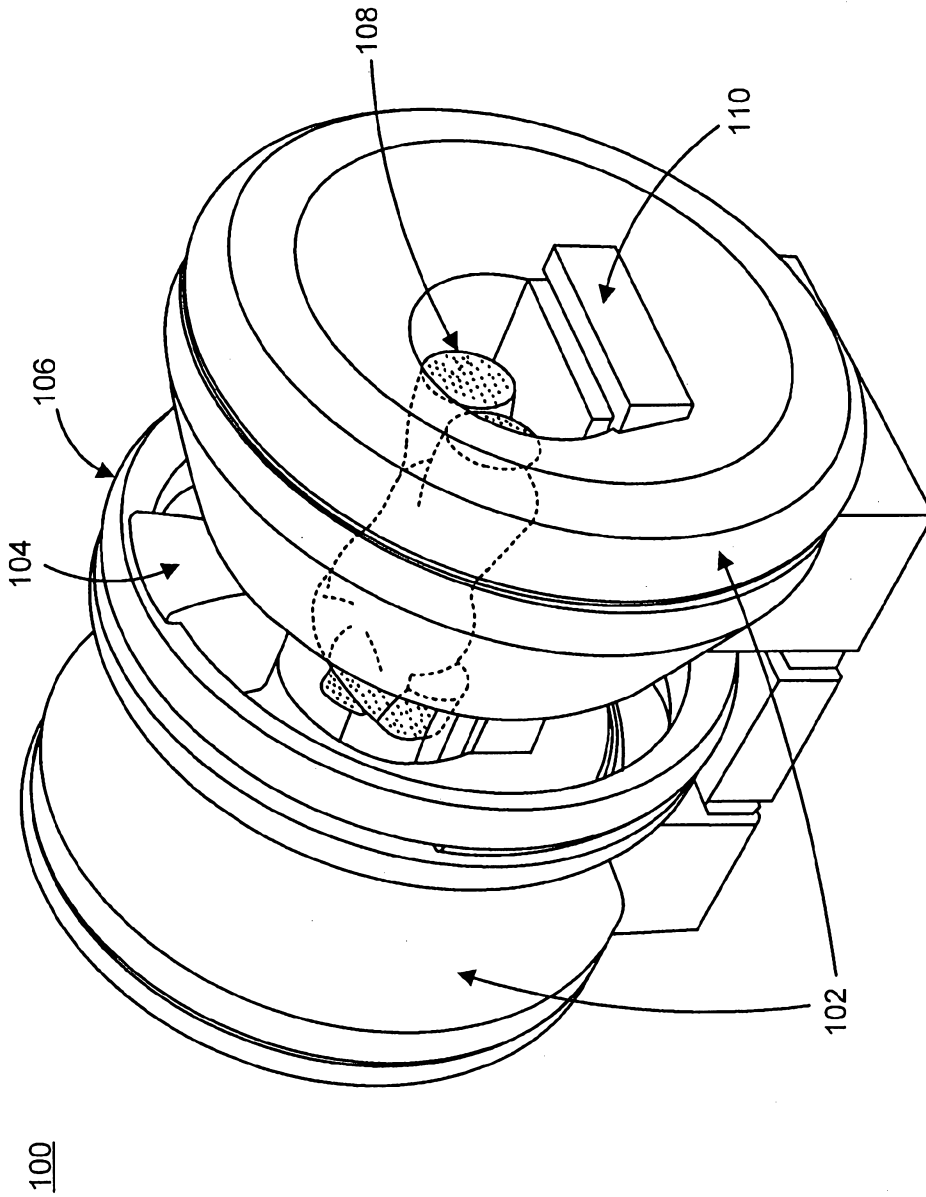

FIG. 1

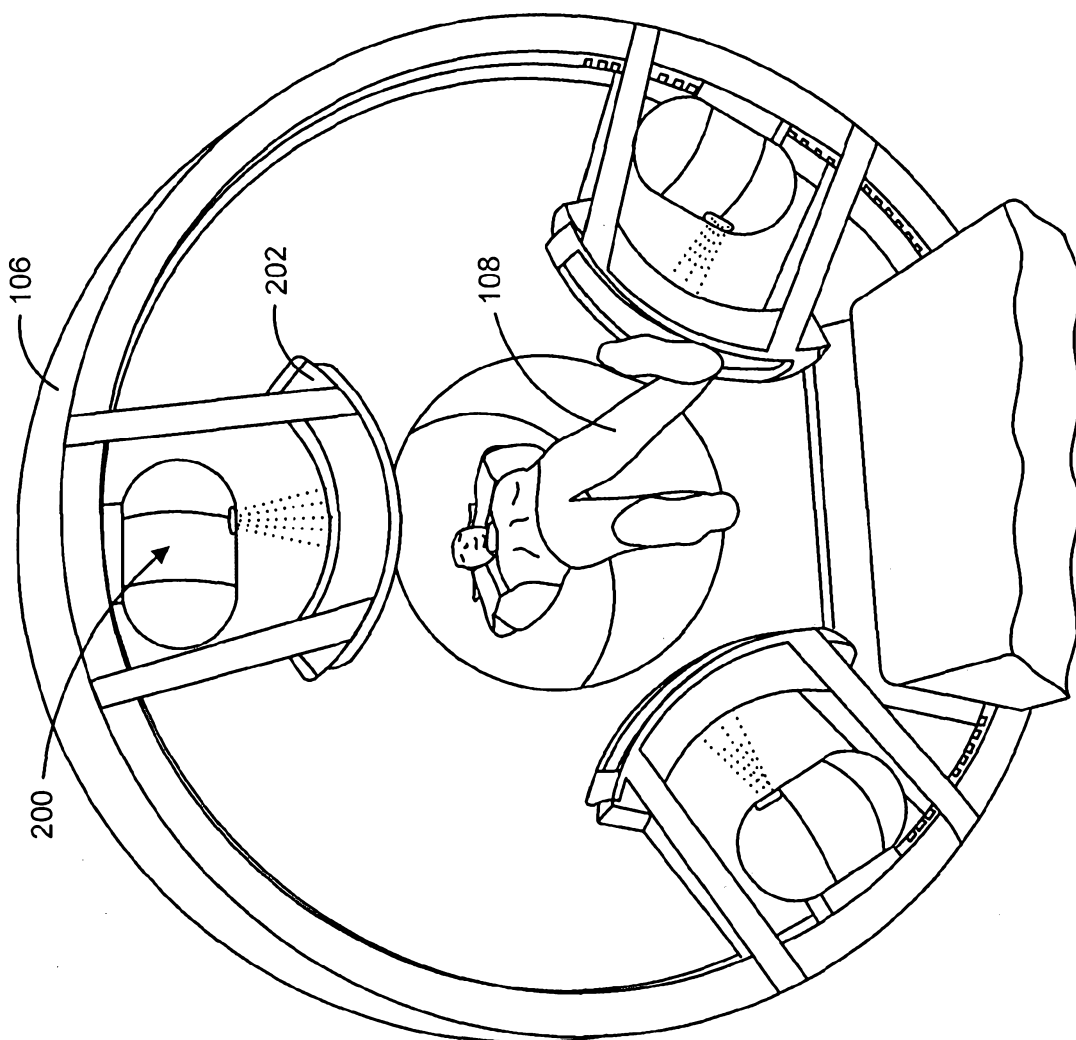

FIG. 2

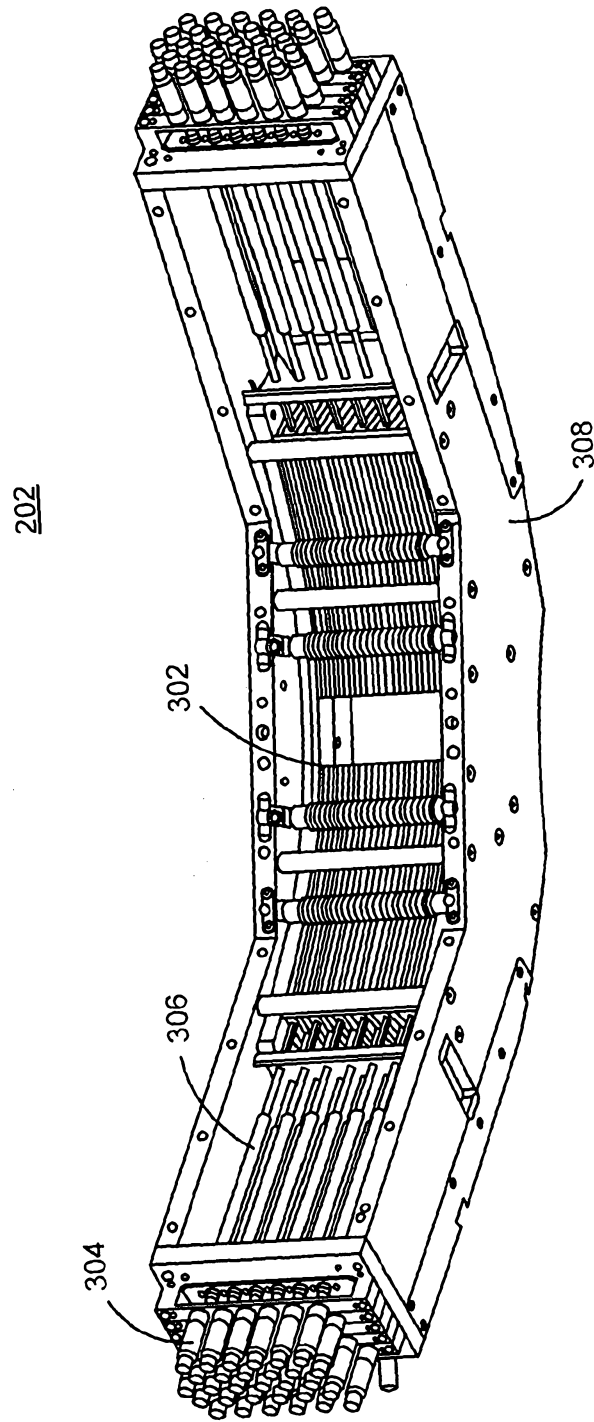

FIG. 3

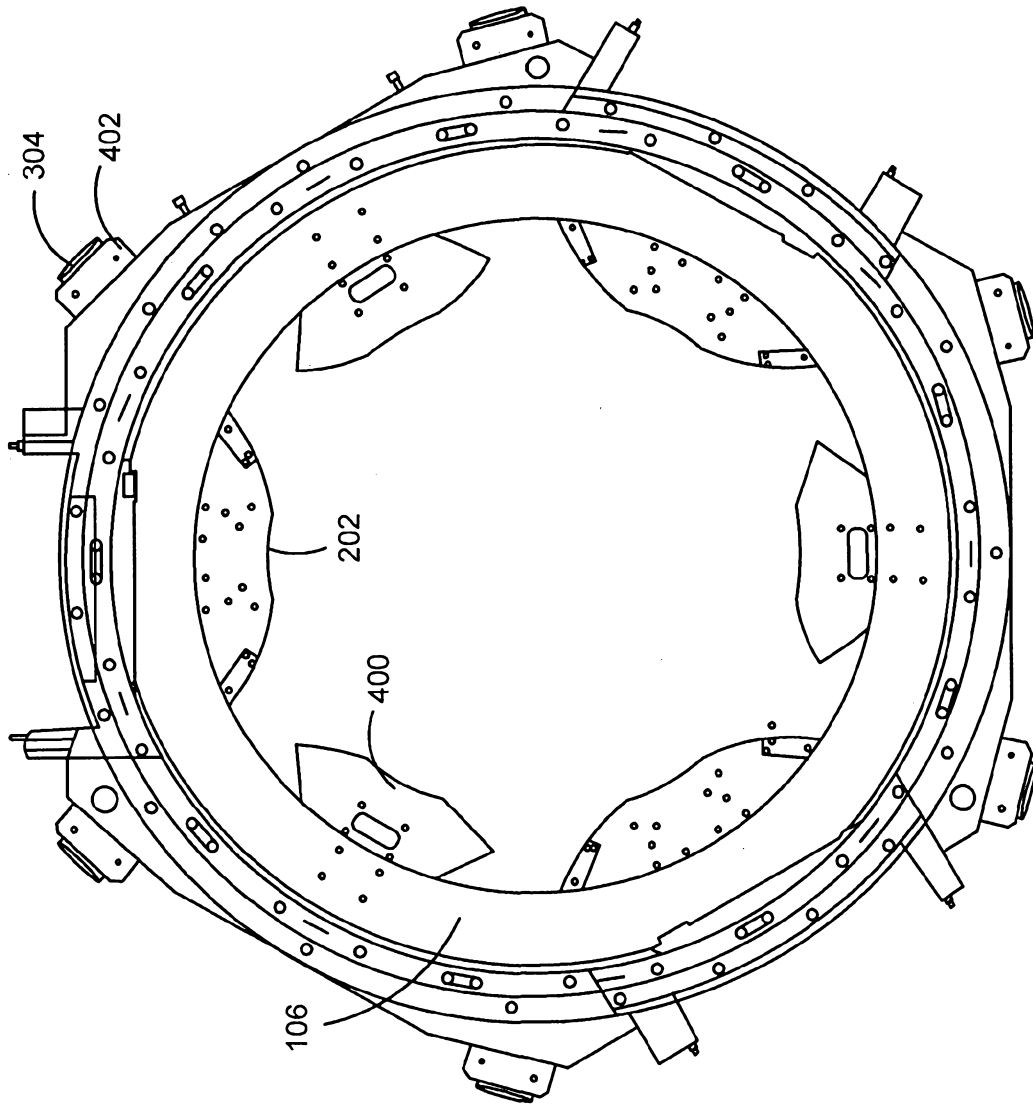

FIG. 4

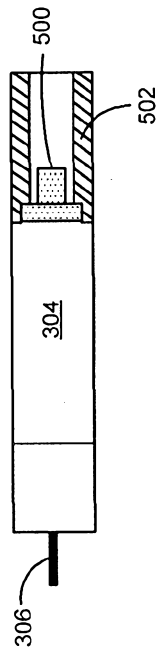

FIG. 5A

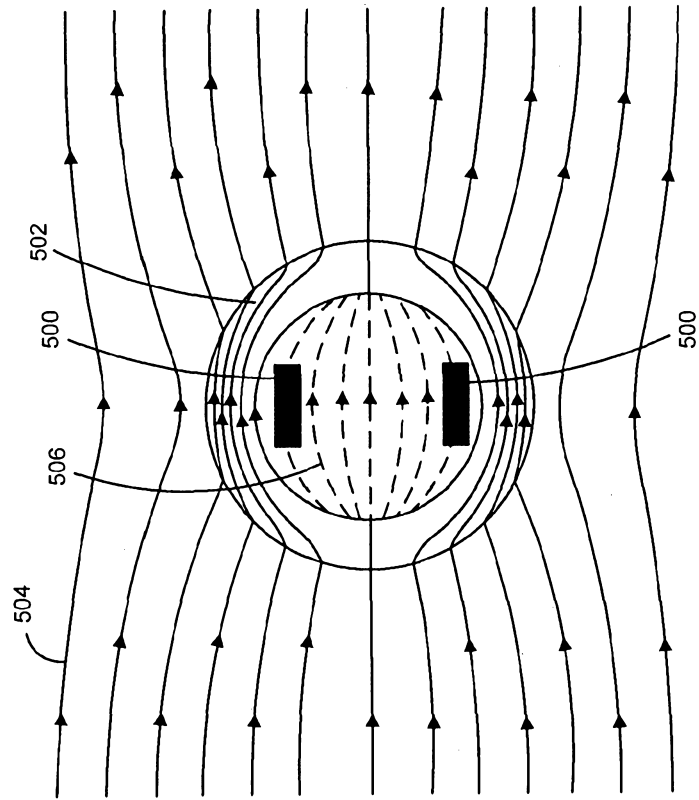

FIG. 5B

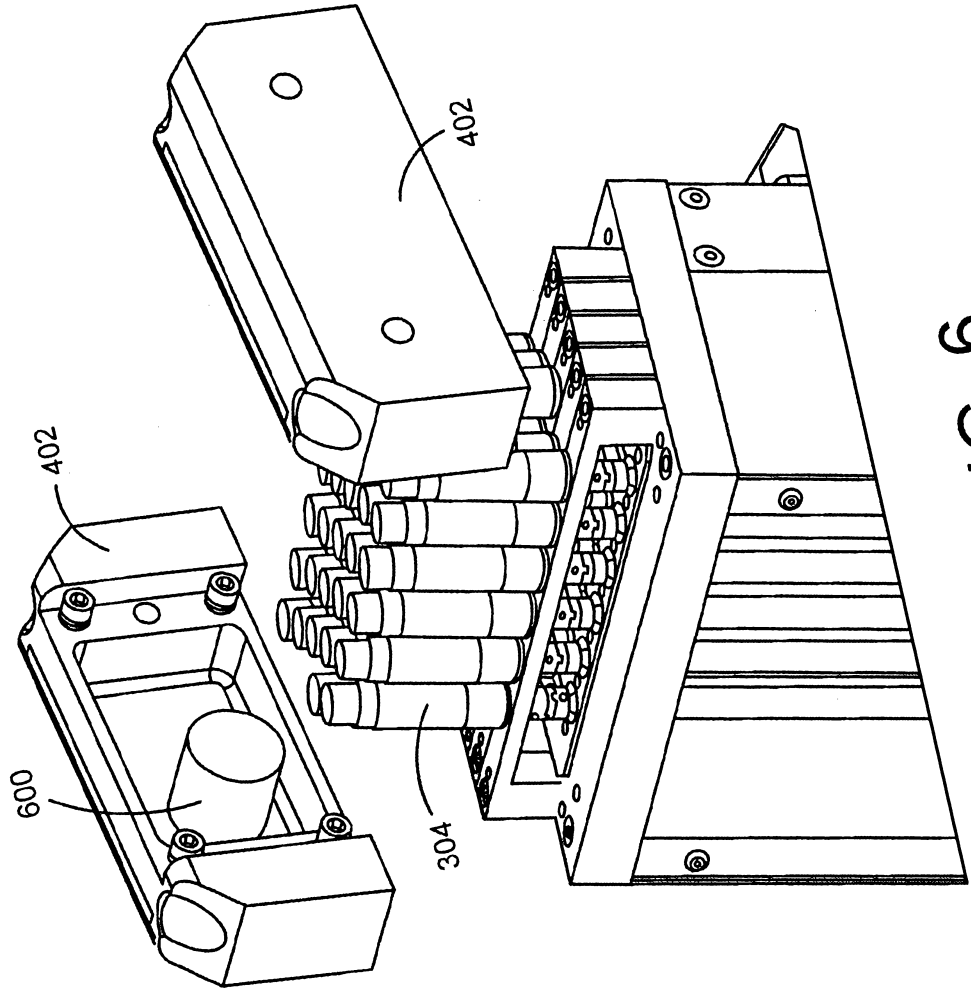

FIG. 6

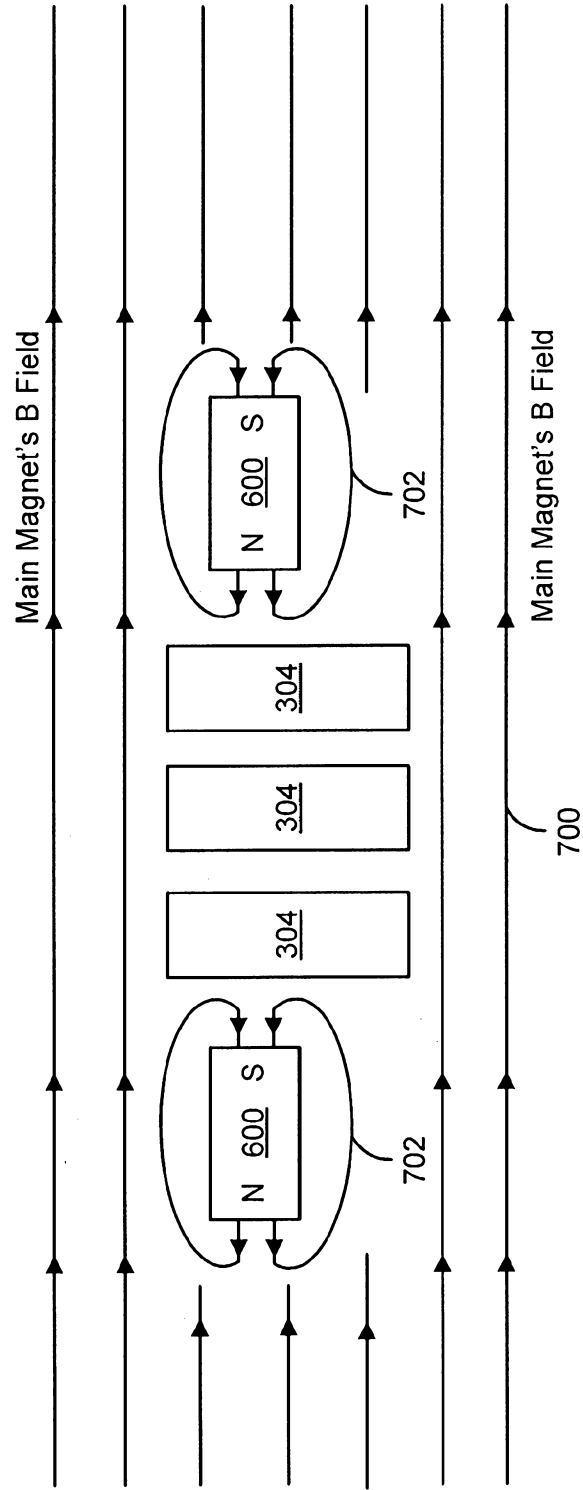



FIG. 7

800 

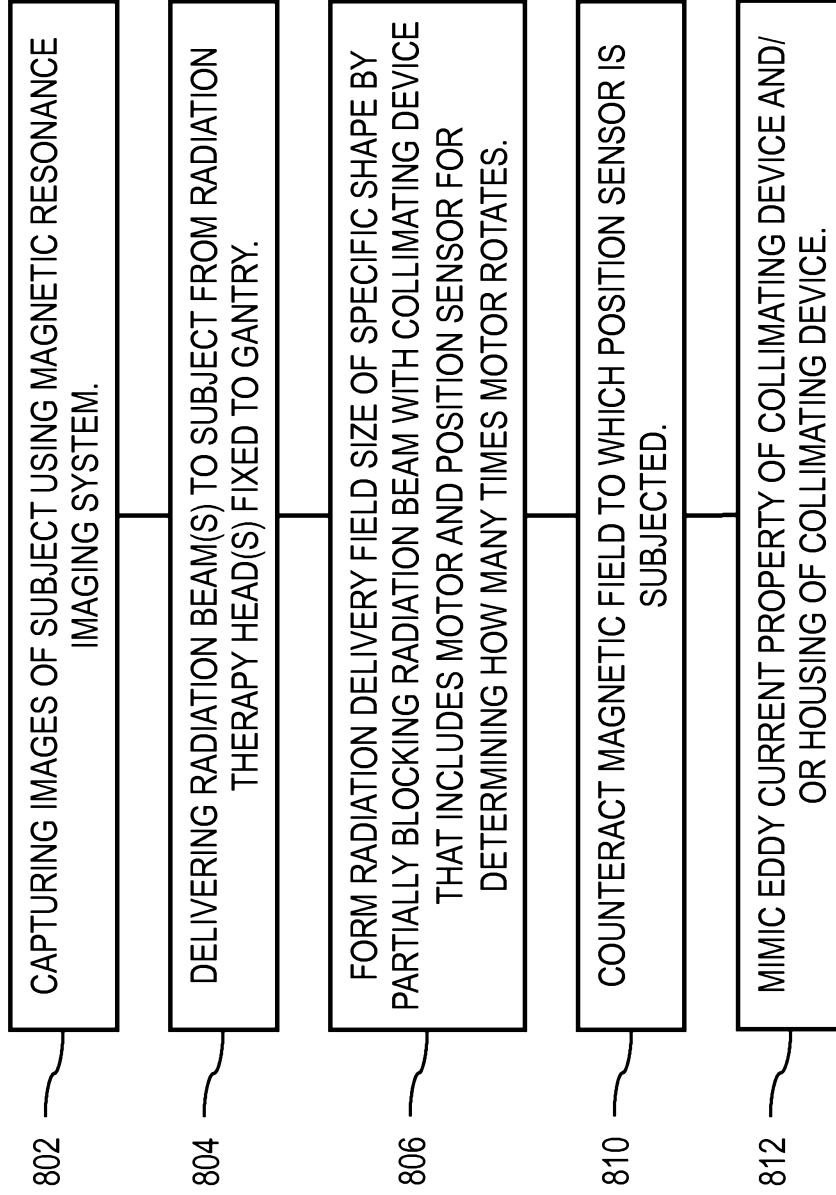

FIG. 8