

(19)
(12)

(KR)
(A)

(51) 。 Int. Cl.7
H01L 27/112
H01L 21/8246

(11)
(43)

2003-0063641
2003 07 31

(21) 10-2002-0003871
(22) 2002 01 23

(71) 3 416

(72) 8 1657-46 B1

836 1601

(74)

:

(54)

가

가

7

1 3

4 6

(Mask ROM) 가 가
 (flat NOR-type ROMs) 가 가
 (NAND-type ROMs) 가 가
 (NOR-type ROMs) 가 가

1 3
 1 (10) (20), (30) (30) (40)
 (40) (30) (SiON) (30) (40)

0) (50) (10) (40) (As) (30) (20) (10) (50)

2 (50) (40) (30) (30) (30)
 (H₂PO₄) (30) (20) (20)

가 / 가
 (10) 가

3 (60, 65) (10) (20) (60, 65)

(50) 850 (50) (55) (50)

(55) / / (55)

(60, 65) 2 (30) (t_{ox}) (10)
 (As) (60) t_{ox} (55) (short channel effect)가

(50) (l₁)가 가

(50)

(65)

(50)

(60)

가

10

$^{18} \text{ atoms/cm}^3$

가

3

4 6

4

(100)

(110),

(120)

()

(135)

(130)

(135)

(135)

(120)

(110) , (100) ,
 (110) 850 (110)
 (120) (130) (anti-reflection)
 (120) 가 , (120)
 (120) 10 1000
 (120) (120) (SiON)
 (ARC,)
 5 (120) (130) (135) (135)
 (120) (120) (135) (120)
 (121)
 (130) (135)
 (100) (As) (140) 10¹⁴ atoms/cm²
 (dose) (110) (100) (120)
 (121)
 (140) (100) (110)
 (120) 가 (110)
 6 (120) (140) (120) (130)
 (130) (130) 4
 (110) (120) (110)
 (110) (120) (110)
 (110)
 (120) ()
 (140) 가 (120) (110)
 (150, 125) (150) (125) (200)
 (110) (200)

, (110) (140) (110) (140) ,
 (110) (200) (140) ,
 , (110) ,
 , (200) , ,
 7 ,
 7 (140) (100) (140) (As)
 (140) 10¹⁸ atoms/cm³ /
 , (140) ,
 (200) (140) (200) (140) 가
 (200) (125) (150) (150) (150)
 (125) (150) ()
 , (125) , (140) , 가
 (125) (140) (140) (140)
 10 (125) (140)
 (110) (100) (125) (110) 가
 (110) (200) ,

(57)

1.

1 2. ,

1 3. ,

1 4. ,

1 5. ,

5 6. ,

1 7. ,

1 8. ,

9.

가 ;

9 10. ,

10^{18} atoms/cm³

9 11. ,

11 12.

11 13.

11 14.

1
(종래 기술)

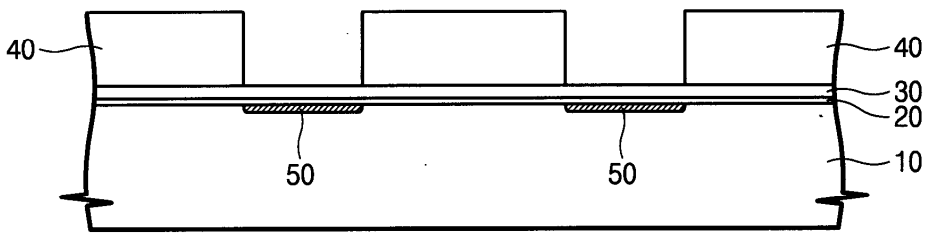

2
(종래 기술)



3
(종래 기술)

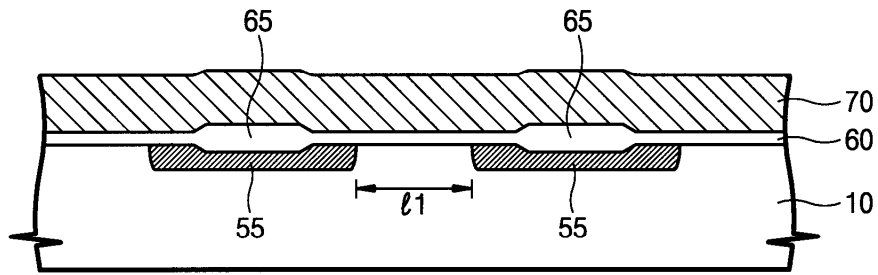

4

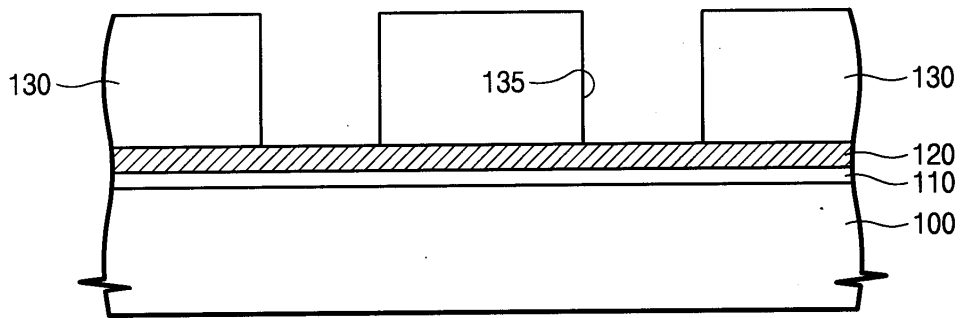

5

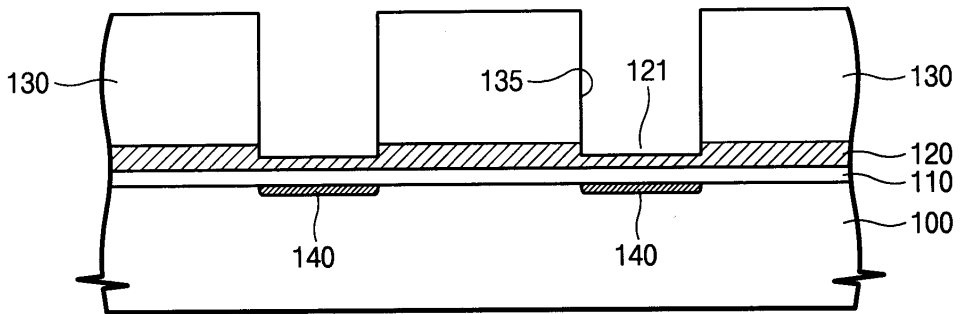

6

