



US00D793300S

(12) **United States Design Patent**
Krieg et al.

(10) **Patent No.:** **US D793,300 S**

(45) **Date of Patent:** **** Aug. 1, 2017**

- (54) **VEHICLE REAR LOWER BUMPER**
- (71) Applicant: **GM GLOBAL TECHNOLOGY OPERATIONS LLC**, Detroit, MI (US)
- (72) Inventors: **Robin Krieg**, Bloomfield Hills, MI (US); **Brian J. Smith**, Farmington Hills, MI (US)
- (73) Assignee: **GM Global Technology Operations LLC**, Detroit, MI (US)
- (**) Term: **15 Years**
- (21) Appl. No.: **29/552,644**
- (22) Filed: **Jan. 25, 2016**
- (51) **LOC (10) Cl.** **12-16**
- (52) **U.S. Cl.**
USPC **D12/169**
- (58) **Field of Classification Search**
USPC D12/169, 216, 90-92, 86, 171, 196, 163;
293/102, 113, 115, 117, 120; 296/180.1,
296/180.2
CPC B60R 19/02; B60R 19/04; B62D 25/08
See application file for complete search history.

- D608,690 S 1/2010 Folden et al.
- D608,691 S 1/2010 Zak, Jr. et al.
- D609,608 S 2/2010 Boniface et al.
- D611,387 S 3/2010 Thompson et al.
- D611,879 S 3/2010 Kim et al.
- D612,297 S 3/2010 Peters et al.
- D613,645 S 4/2010 Song et al.
- D615,458 S 5/2010 Thompson et al.
- D618,595 S 6/2010 Ware et al.
- D623,090 S 9/2010 Cox et al.
- D627,262 S 11/2010 Ikeda et al.
- D635,488 S 4/2011 Phipps
- D644,147 S 8/2011 Suh et al.
- D644,567 S 9/2011 Kozub
- D657,718 S 4/2012 Zipfel et al.
- D659,052 S 5/2012 Ware et al.
- D659,053 S 5/2012 Ware et al.
- D668,182 S 10/2012 Barba Franco et al.
- D668,183 S 10/2012 Smart
- D678,820 S 3/2013 Son et al.
- D678,821 S 3/2013 Ikeda et al.
- D680,909 S 4/2013 Munson et al.

(Continued)

Primary Examiner — Melody N Brown
(74) *Attorney, Agent, or Firm* — Reising Ethington P.C.

(57) **CLAIM**

The ornamental design for a vehicle rear lower bumper, as shown and described.

DESCRIPTION

FIG. 1 is a perspective view of the vehicle rear lower bumper;
FIG. 2 is a front view thereof;
FIG. 3 is a top view thereof; and,
FIG. 4 is a left side elevation view thereof, the right side is a mirror image thereof.
The broken lines shown in the drawings depict portions of the vehicle rear lower bumper that form no part of the claimed design.

1 Claim, 2 Drawing Sheets

(56) **References Cited**
U.S. PATENT DOCUMENTS

- D570,742 S 6/2008 Takagi et al.
- D592,105 S 5/2009 Dean et al.
- D597,447 S 8/2009 Folden
- D600,595 S 9/2009 Nakamura et al.
- D601,925 S 10/2009 O'Donnell
- D603,755 S 11/2009 Peters
- D604,203 S 11/2009 O'Donnell
- D605,082 S 12/2009 Munson
- D605,083 S 12/2009 Manoogian, II et al.
- D605,977 S 12/2009 Zipfel et al.
- D605,978 S 12/2009 Wolff et al.
- D608,249 S 1/2010 Peters

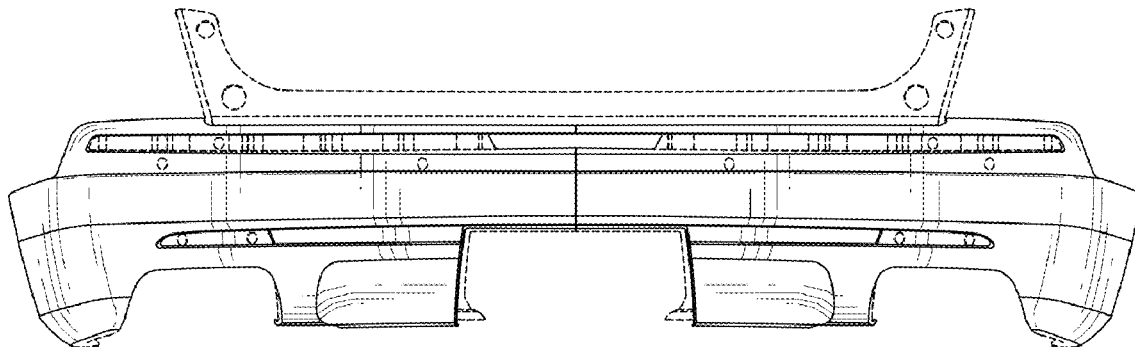

(56)

References Cited

U.S. PATENT DOCUMENTS

D680,910 S	4/2013	David	D732,431 S	6/2015	Loeb	
D684,899 S	6/2013	Baker	D732,432 S	6/2015	Aengenheyster	
D686,536 S	7/2013	McCabe et al.	D732,433 S	6/2015	Aengenheyster	
D692,798 S	11/2013	Thurber	D732,435 S	6/2015	Mackay	
D692,799 S	11/2013	Smith et al.	D733,002 S	6/2015	Loeb	
D696,157 S	12/2013	Loeb	D735,611 S	8/2015	Aengenheyster	
D699,629 S	2/2014	Ikeda et al.	D735,627 S	8/2015	Smith	
D700,871 S	3/2014	O'Donnell et al.	D736,451 S	8/2015	Smith	
D703,103 S	4/2014	Lee	D739,306 S	9/2015	McMahan et al.	
D704,103 S	5/2014	Mack et al.	D739,317 S	9/2015	McMahan et al.	
D705,132 S	5/2014	Ware et al.	D741,223 S	10/2015	Kim et al.	
D705,699 S	5/2014	Ware et al.	D743,309 S	11/2015	Thole et al.	
D708,994 S *	7/2014	Thurber D12/169	D743,313 S	11/2015	Smith et al.	
D713,298 S	9/2014	Dyson	D743,314 S	11/2015	Thole et al.	
D713,764 S	9/2014	Ferlazzo et al.	D743,857 S	11/2015	McMahan et al.	
D716,696 S	11/2014	Thole et al.	D744,158 S	11/2015	Willett et al.	
D716,706 S	11/2014	Thole et al.	D745,086 S	12/2015	Finos et al.	
D716,709 S	11/2014	Thole et al.	D745,719 S	12/2015	Boniface et al.	
D717,696 S	11/2014	Thole et al.	D745,725 S	12/2015	McMahan et al.	
D718,189 S	11/2014	Krieg et al.	D745,726 S	12/2015	McMahan et al.	
D718,683 S	12/2014	Thole et al.	D745,837 S	12/2015	Smith et al.	
D722,282 S	2/2015	Loeb	D746,726 S	1/2016	Smith et al.	
D722,533 S	2/2015	Thole et al.	D746,727 S	1/2016	Smith et al.	
D722,534 S	2/2015	Munson et al.	D746,728 S	1/2016	Smith et al.	
D724,510 S	3/2015	McMahan et al.	D746,729 S	1/2016	Boniface et al.	
D725,001 S	3/2015	McMahan et al.	D746,730 S	1/2016	Kim et al.	
D726,591 S	4/2015	Jacob	D747,514 S	1/2016	McMahan et al.	
D730,776 S	6/2015	Smart	D747,515 S	1/2016	McMahan et al.	
D730,783 S	6/2015	Henriques et al.	D747,819 S	1/2016	Thole et al.	
D732,427 S	6/2015	Loeb	D760,129 S *	6/2016	Whang D12/169	
D732,429 S	6/2015	Loeb	D766,789 S *	9/2016	Kapitonov D12/169	
D732,430 S	6/2015	Loeb	D773,352 S *	12/2016	Munakata D12/169	
			D773,353 S *	12/2016	Munakata D12/169	
			D775,038 S *	12/2016	Frascella D12/169	

* cited by examiner

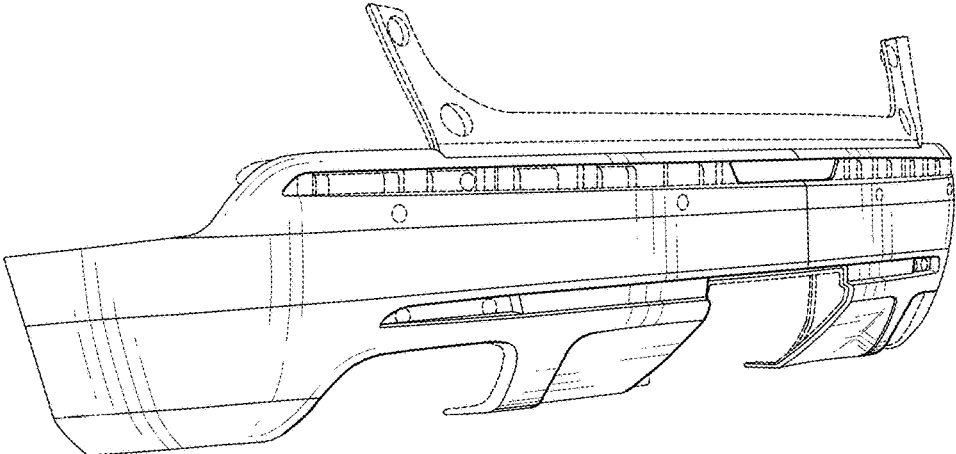

Fig. 1

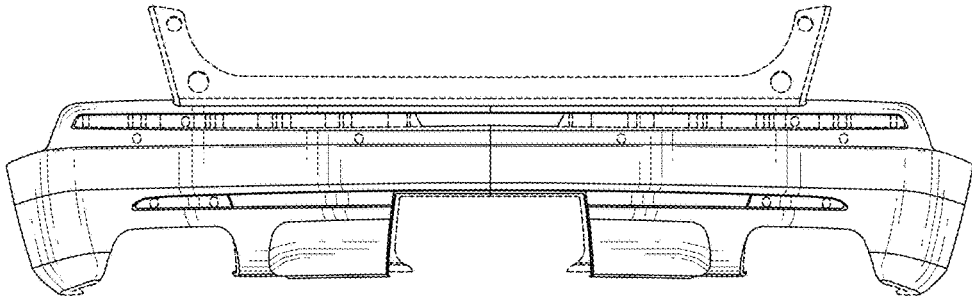

Fig. 2

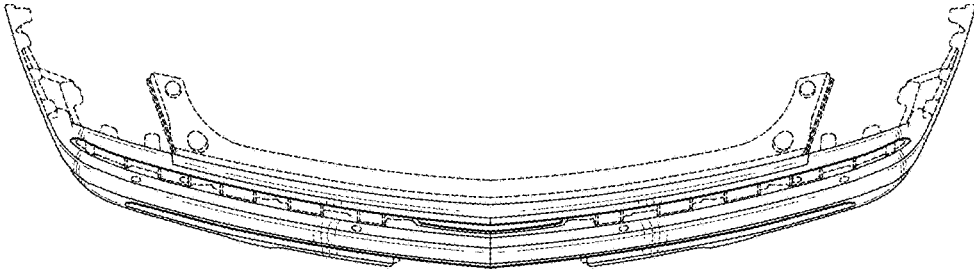

Fig. 3

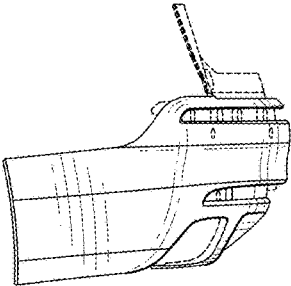

Fig. 4