

(12) **UK Patent Application** (19) **GB** (11) **2 367 512** (13) **A**

(43) Date of A Publication **10.04.2002**

(21) Application No **0116411.0**

(22) Date of Filing **05.07.2001**

(30) Priority Data

| | | |
|---------------------|------------------------|----------------|
| (31) 0016501 | (32) 06.07.2000 | (33) GB |
| (31) 0016503 | (32) 06.07.2000 | |
| (31) 0027593 | (32) 13.11.2000 | |
| (31) 0016504 | (32) 06.07.2000 | |
| (31) 0022610 | (32) 15.09.2000 | |

(51) INT CL⁷

B04C 7/00 // B04C 9/00

(52) UK CL (Edition T)

B2P P1A

(56) Documents Cited

GB 2169822 A **GB 2020205 A**

(58) Field of Search

UK CL (Edition T) **B2P P1A P1B P10B2C**

INT CL⁷ **B04C**

ONLINE: WPI, JAPIO, EPODOC

(71) Applicant(s)

John Herbert North
21 Briar Court, Guardian Road, NORWICH, Norfolk,
NR5 8PR, United Kingdom

(72) Inventor(s)

John Herbert North

(74) Agent and/or Address for Service

Keith W Nash & Co
90-92 Regent Street, CAMBRIDGE, CB2 1DP,
United Kingdom

(54) Abstract Title

Multiple cyclone separation unit

(57) A multistage air-particle separator comprises at least two separation stages in (18, fig 1) 114 which particle-laden air is drawn through a succession of chambers in turn by suction applied to the last of the chambers. Heavier than air particles are separated from the airstream in each chamber by centrifugal force, and conveyed to a collecting bin (26 or 66, fig 1) and particle depleted air is drawn from each chamber by suction. An intermediate separation stage comprises a cylindrical chamber, having a port (48, fig 10) through which air from an earlier stage enters the chamber. The port is arranged so that air entering the chamber does so generally tangentially, and a hollow spindle 90 extends centrally of the chamber and communicates with an opening in a closed end wall of the chamber, leading to the next separation chamber. A turbine 94, 96 is mounted for rotation about the chamber axis and is generally aligned with the port through which air enters the chamber, the incoming air causing the turbine to rotate. At least one opening 62 is provided at or near the end of the hollow spindle through which air can leave the chamber to pass therealong into the next separation stage, and a particle collecting bin (66, fig 1) is provided at the end of the chamber remote from the turbine. The hollow spindle may be stationary and the turbine rotates therearound, or the turbine is attached to the spindle so that the two rotate together. Small openings may be provided in the spindle wall around one end thereof, in which event the turbine is mounted at a position axially distant from the openings. The turbine containing region of the chamber may be separated from the region of the chamber which communicates with the interior of the hollow spindle, by means of an annular baffle 88 containing at least one opening therein through which air can pass from the one region to the other. The rotating spindle imparts rotation to the air passing into the next chamber. In this last chamber the air enters axially and is deflected on entry. A first exit port 118 removes clean air to the suction source 10. A second port 112 may be provided in the wall of the chamber circumferentially spaced from the first port, to allow particles separated in the final stage to be returned via a passage for separation in the rotating airstream in the intermediate chamber. Collecting bin (26, fig 1) is separated from the cyclone chamber (18, fig 1) by a baffle (56, fig 1) to prevent the re-entrainment of

(57) continued overleaf

At least one drawing originally filed was informal and the print reproduced here is taken from a later filed formal copy.

GB 2 367 512 A

(57) cont

particles. Collecting bin (66, fig 1) may be replaced by a valve (see fig 4) which is constructed such that downstream suction forces maintain it in a closed position during operation of the unit, but allows the valve to open when no suction is present. On opening of the valve the collected particles are able to fall into the collecting bin (26, fig 1).

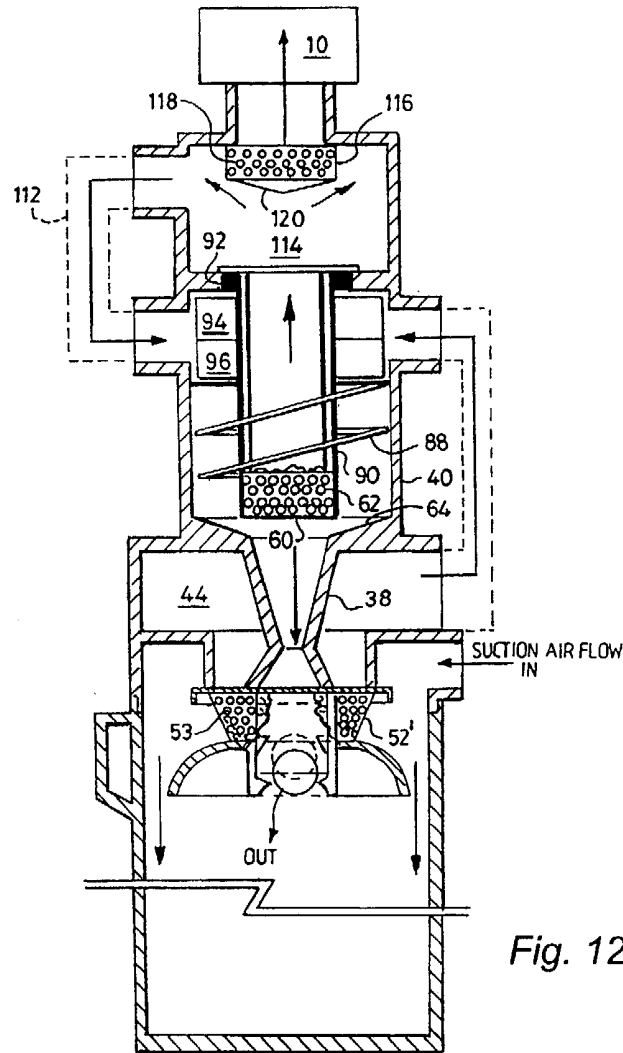

Fig. 12

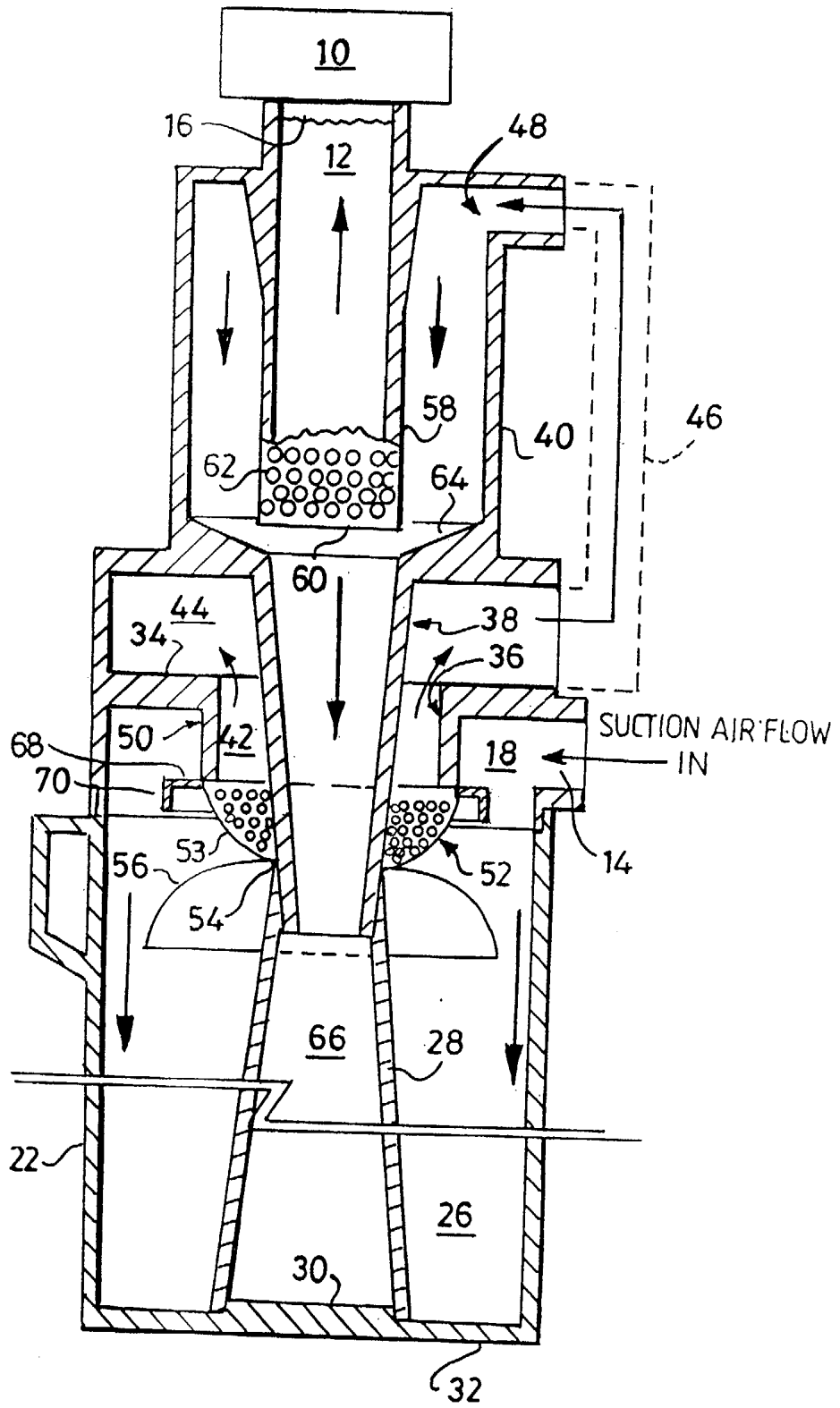

Fig. 1

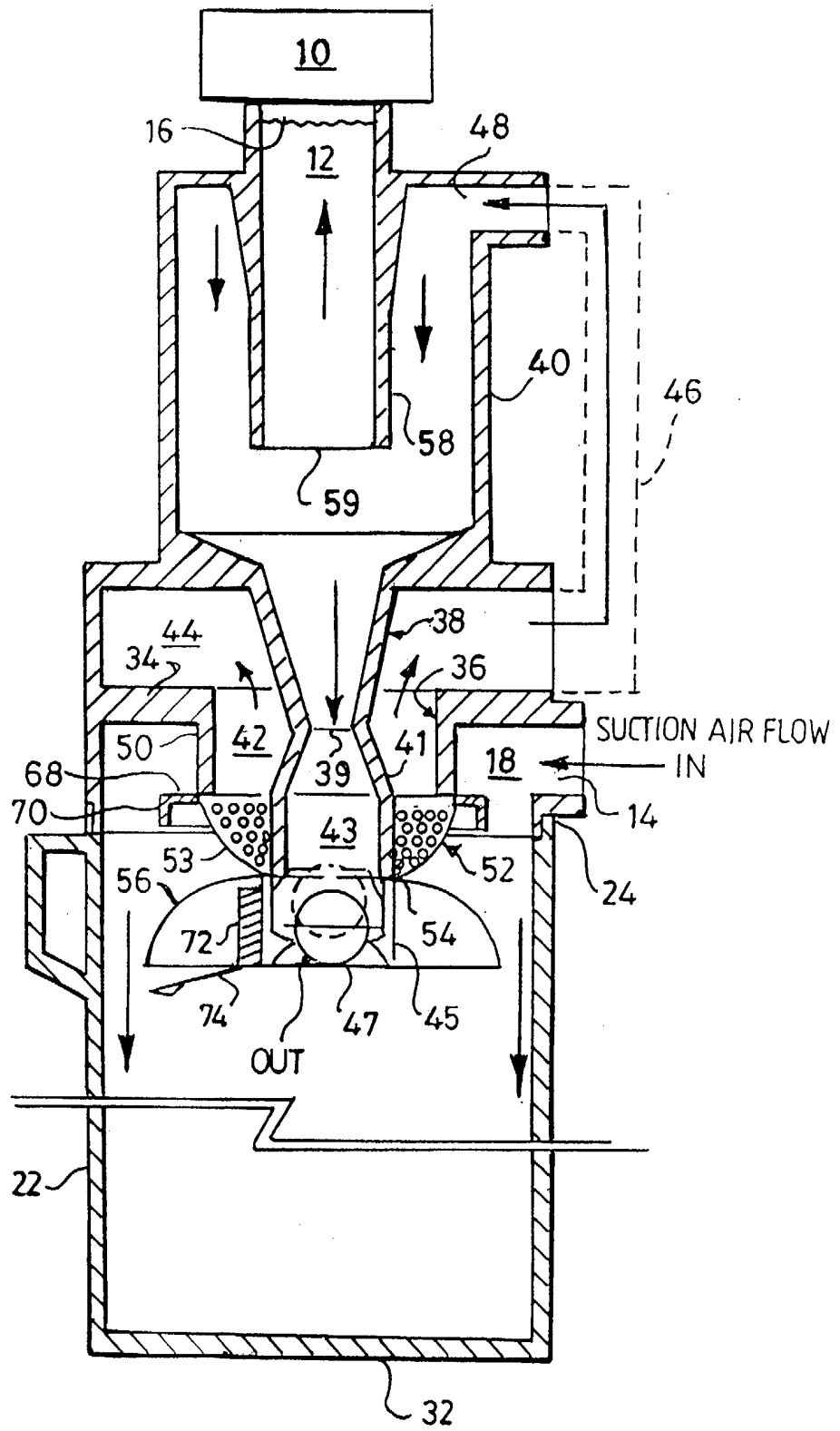

Fig. 2

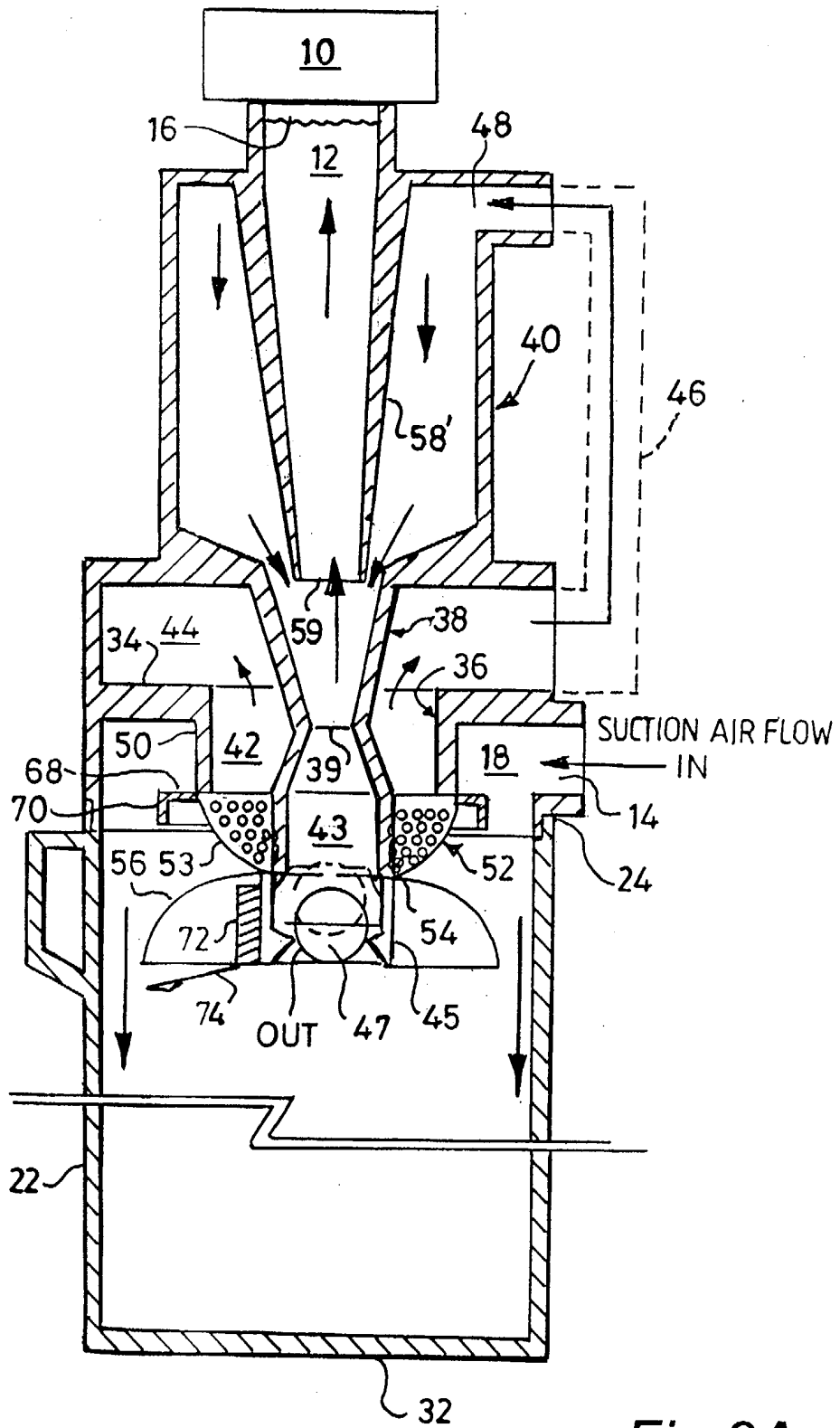

Fig. 2A

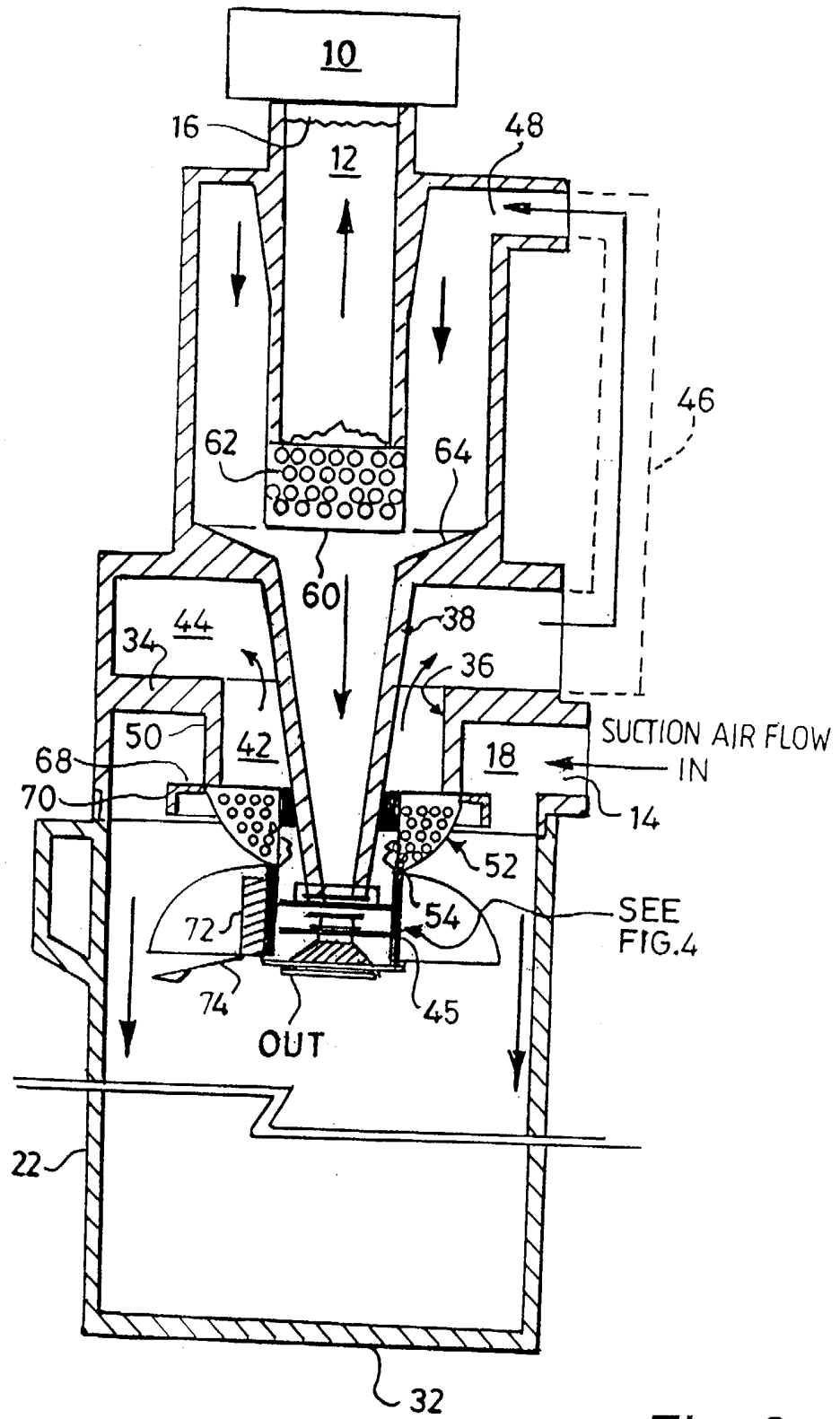

Fig. 3

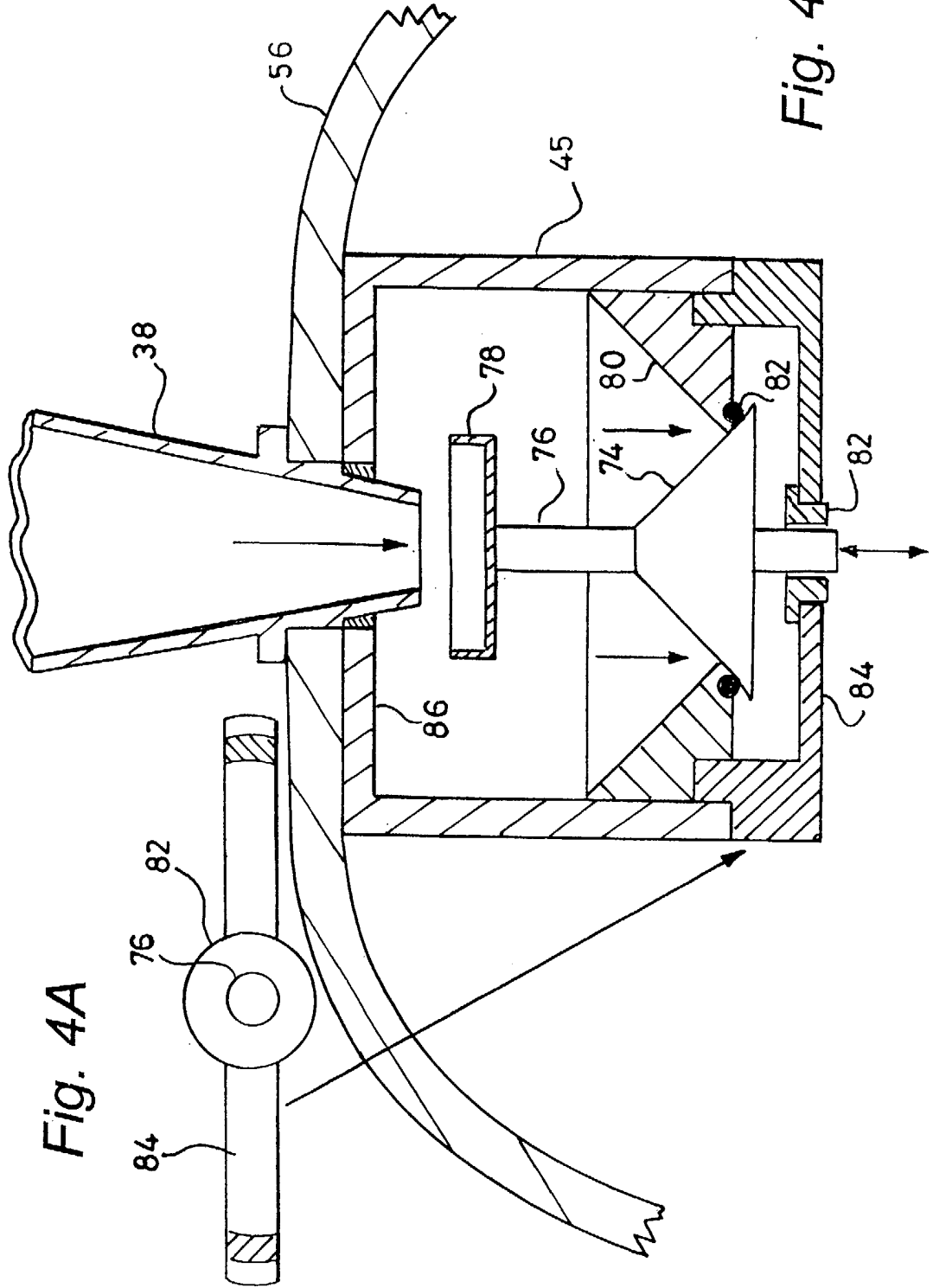

Fig. 4A

Fig. 4

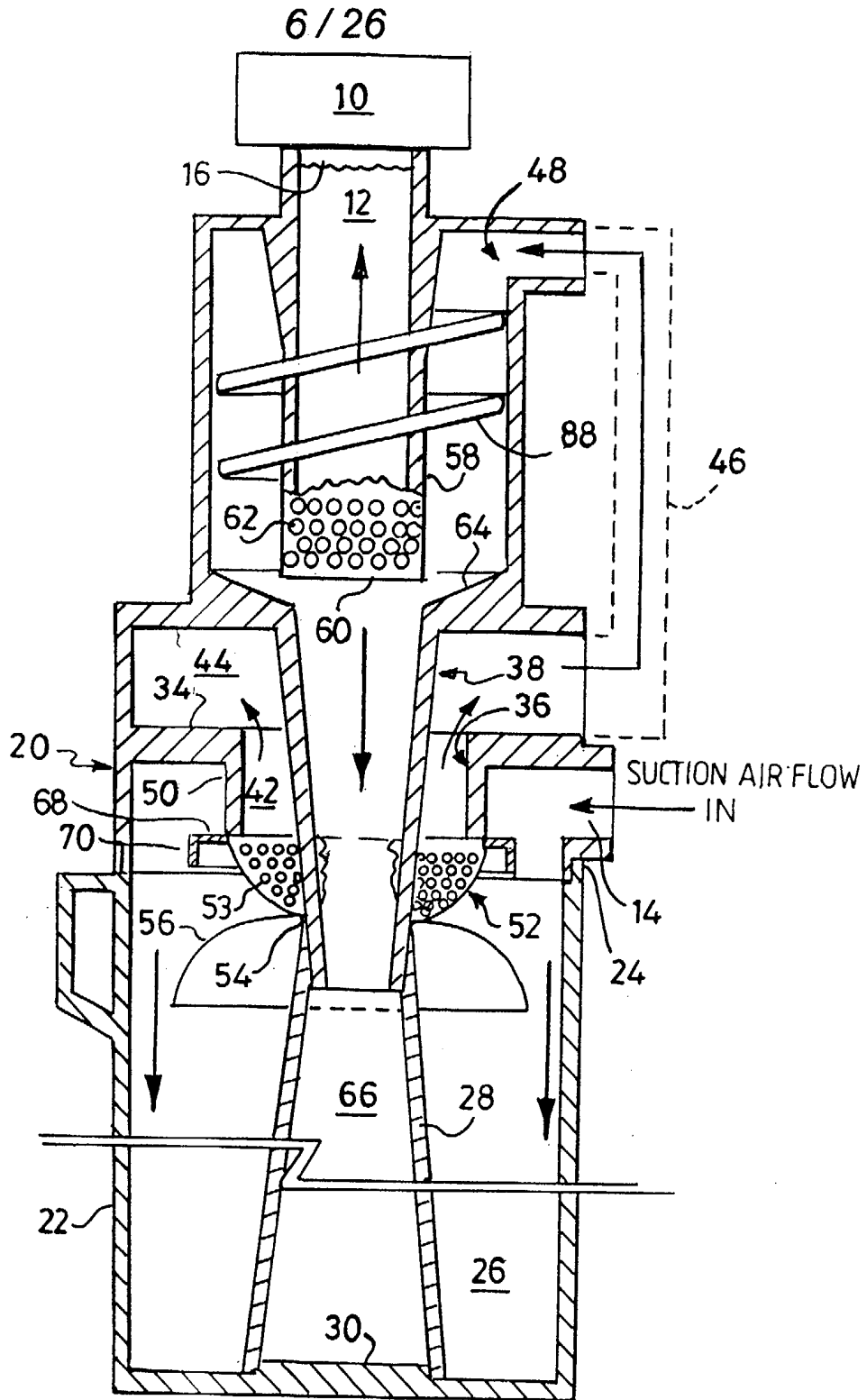

Fig. 5

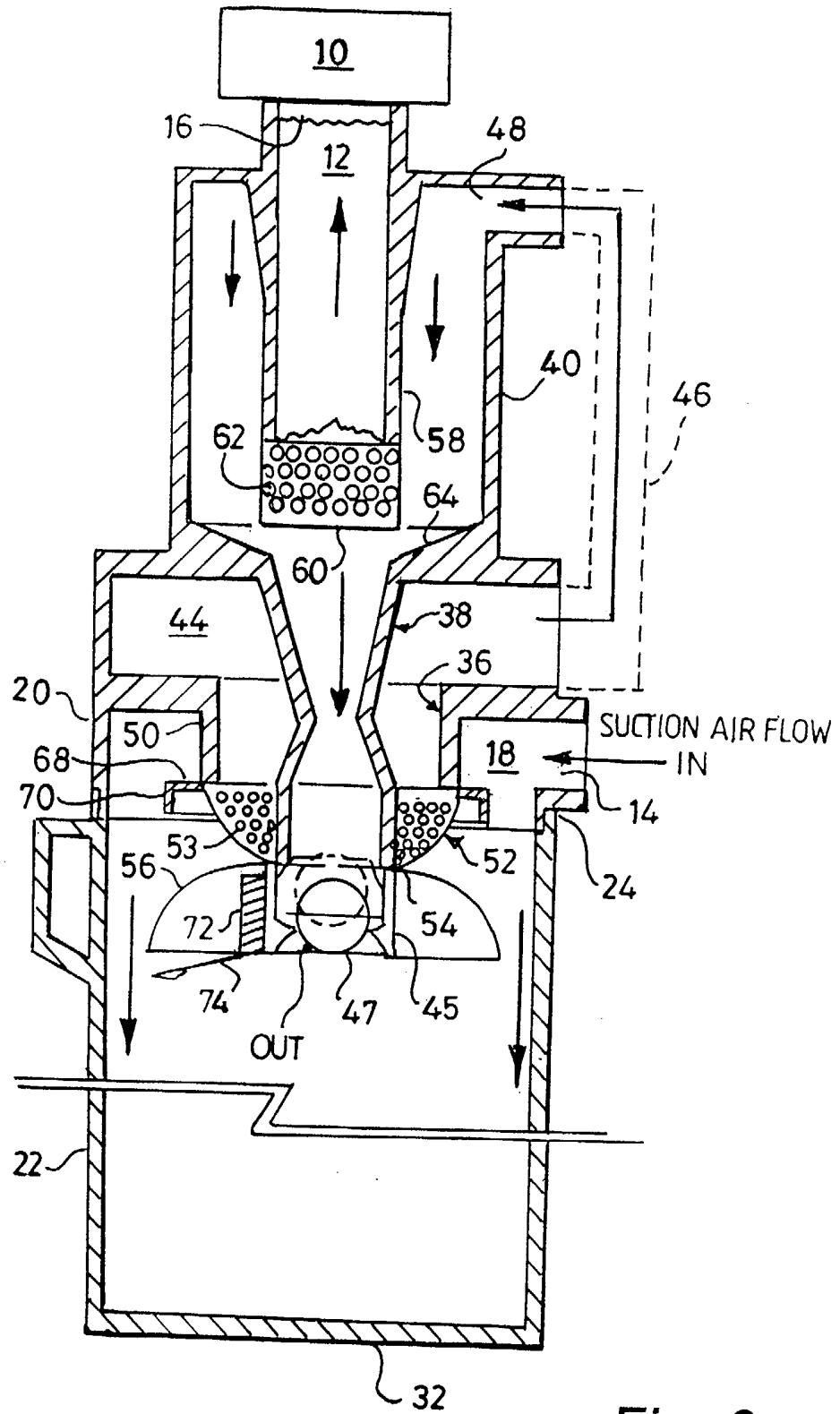

Fig. 6

8/26

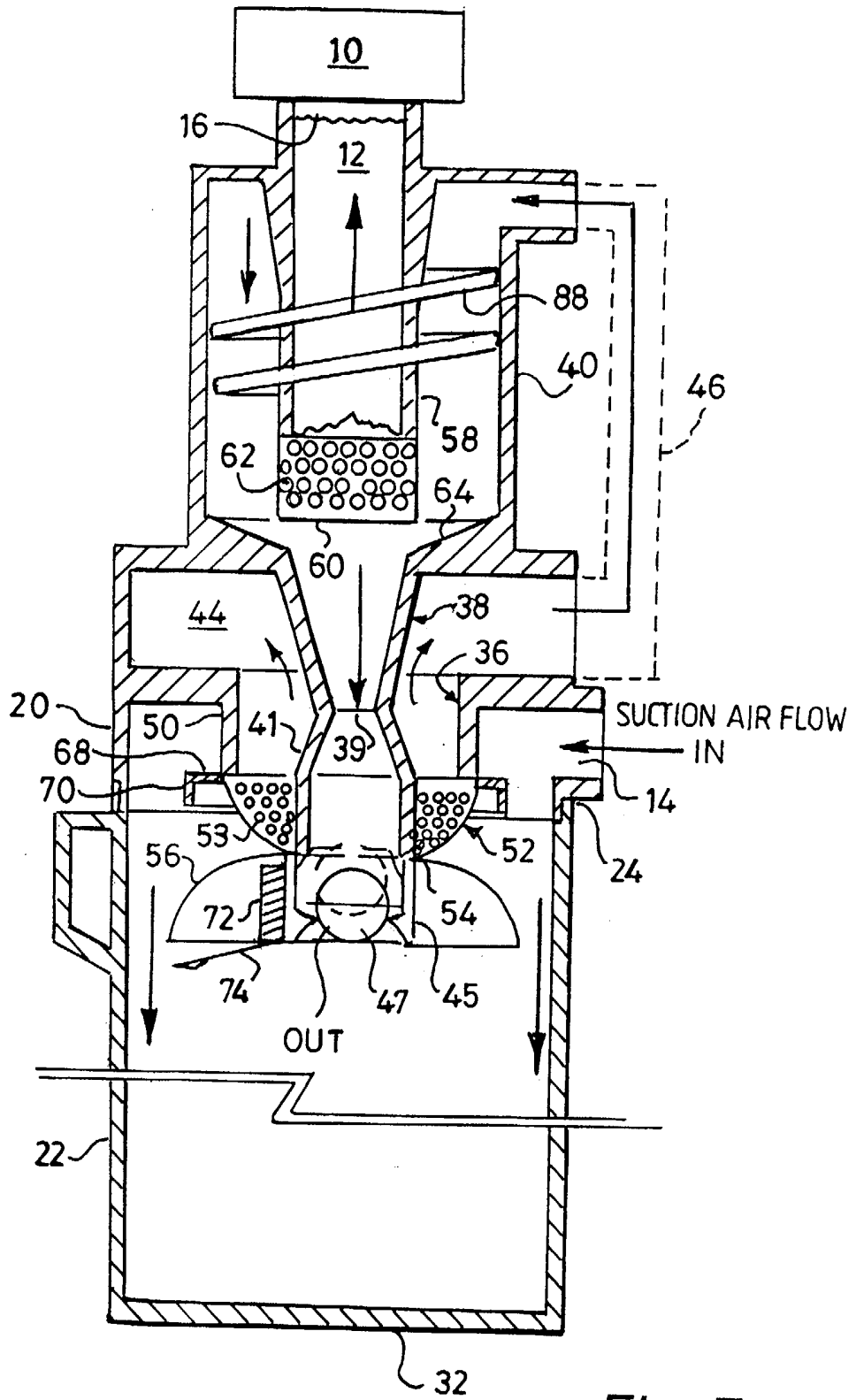

Fig. 7

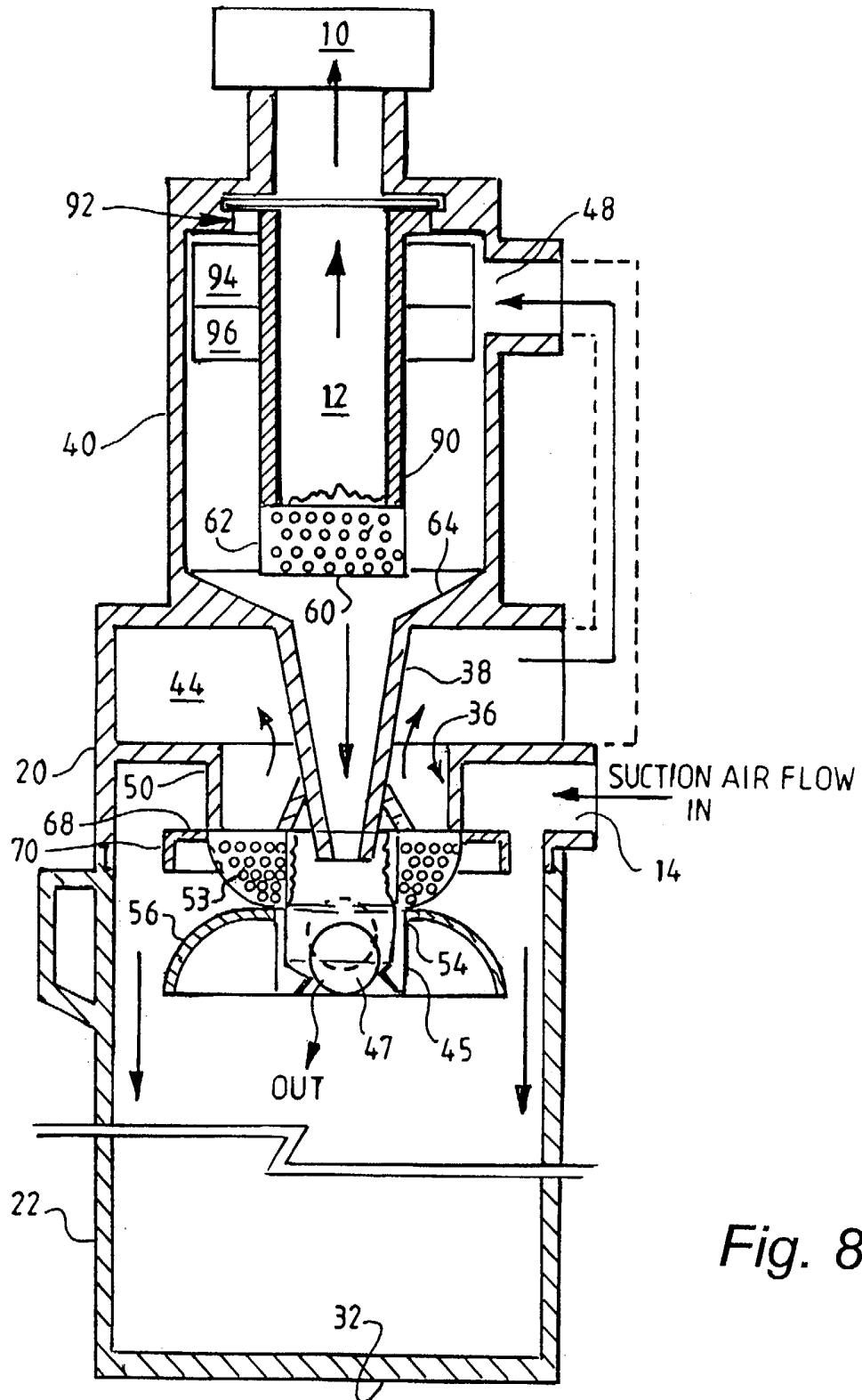

Fig. 8

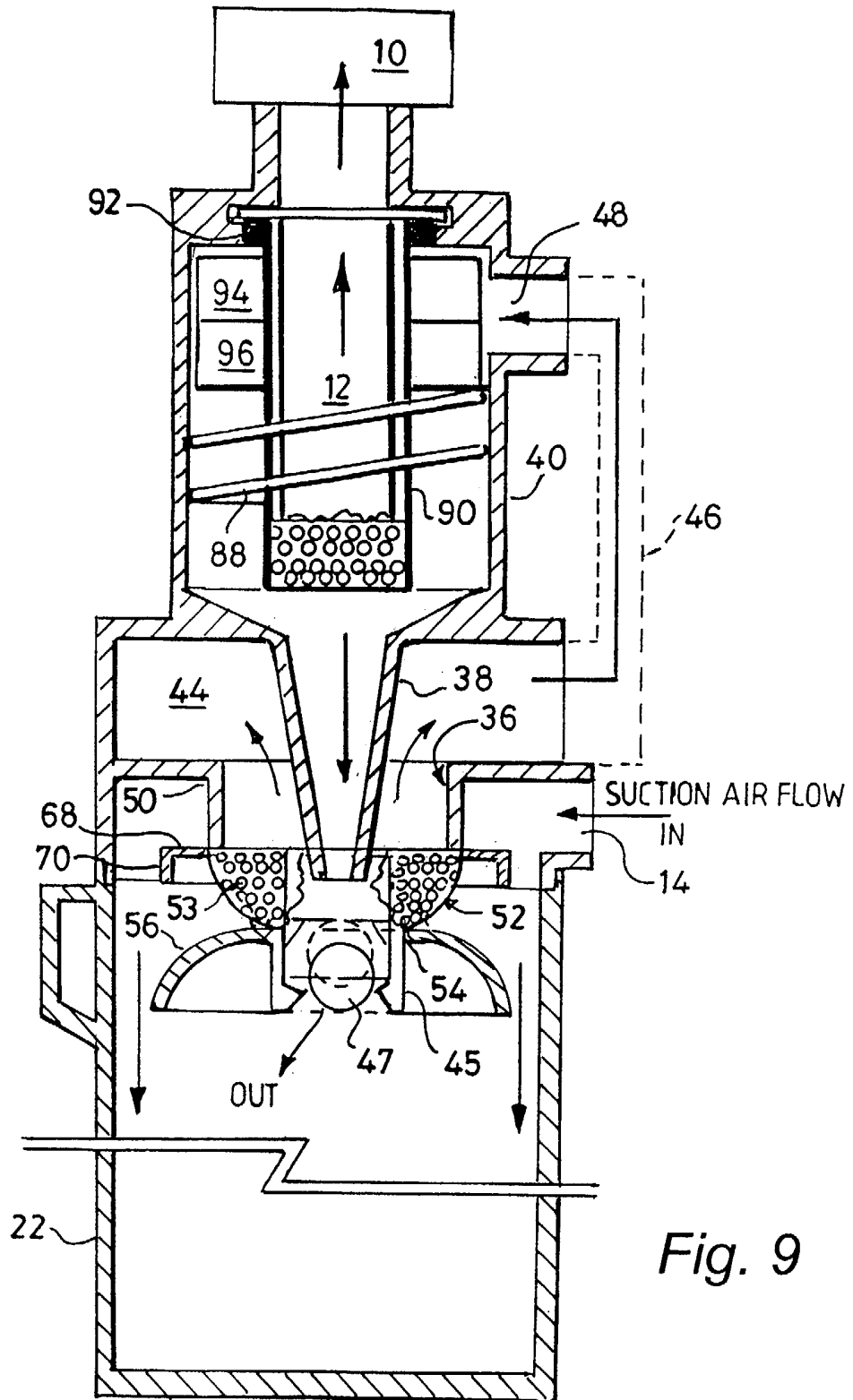

Fig. 9

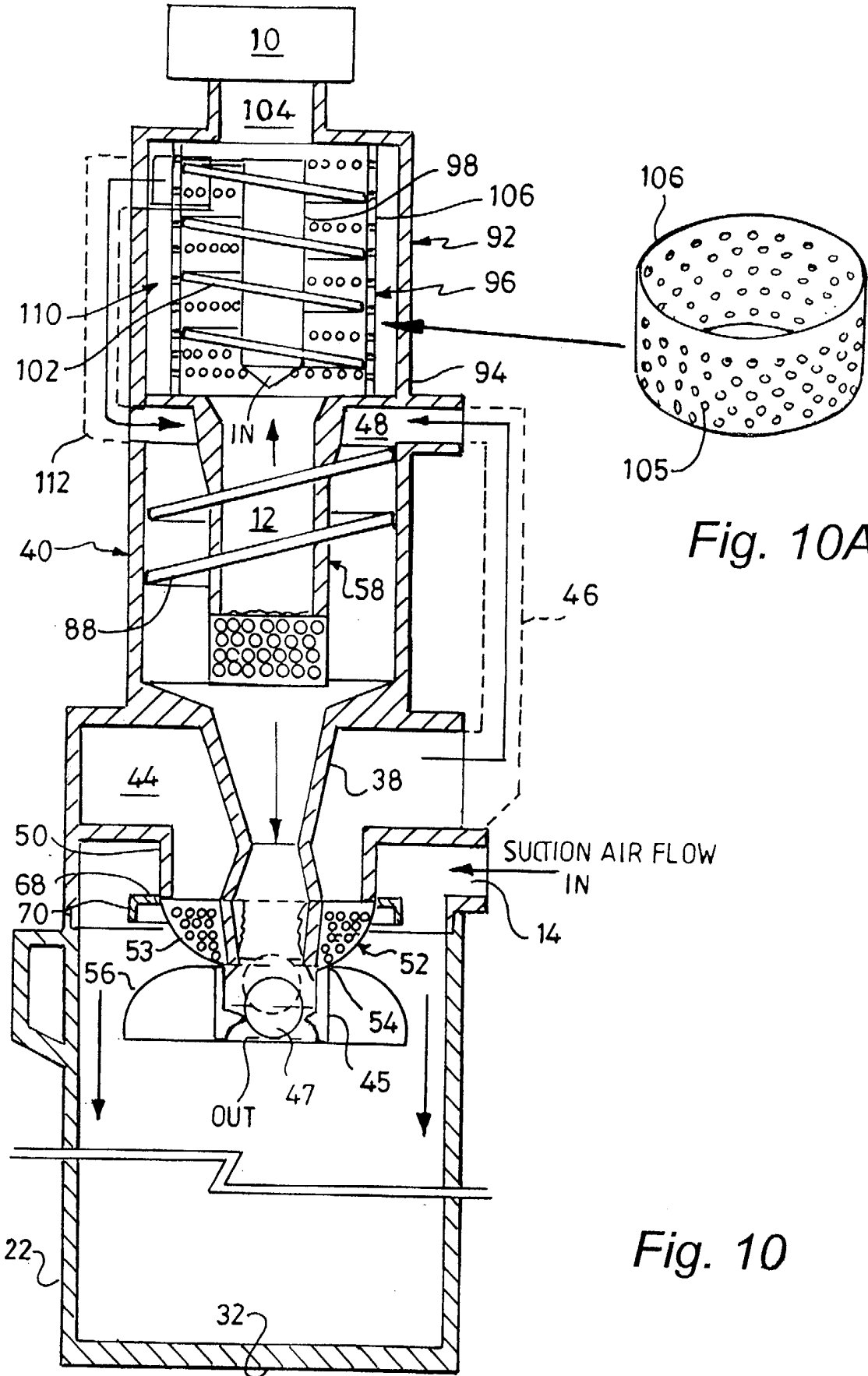

Fig. 10A

Fig. 10

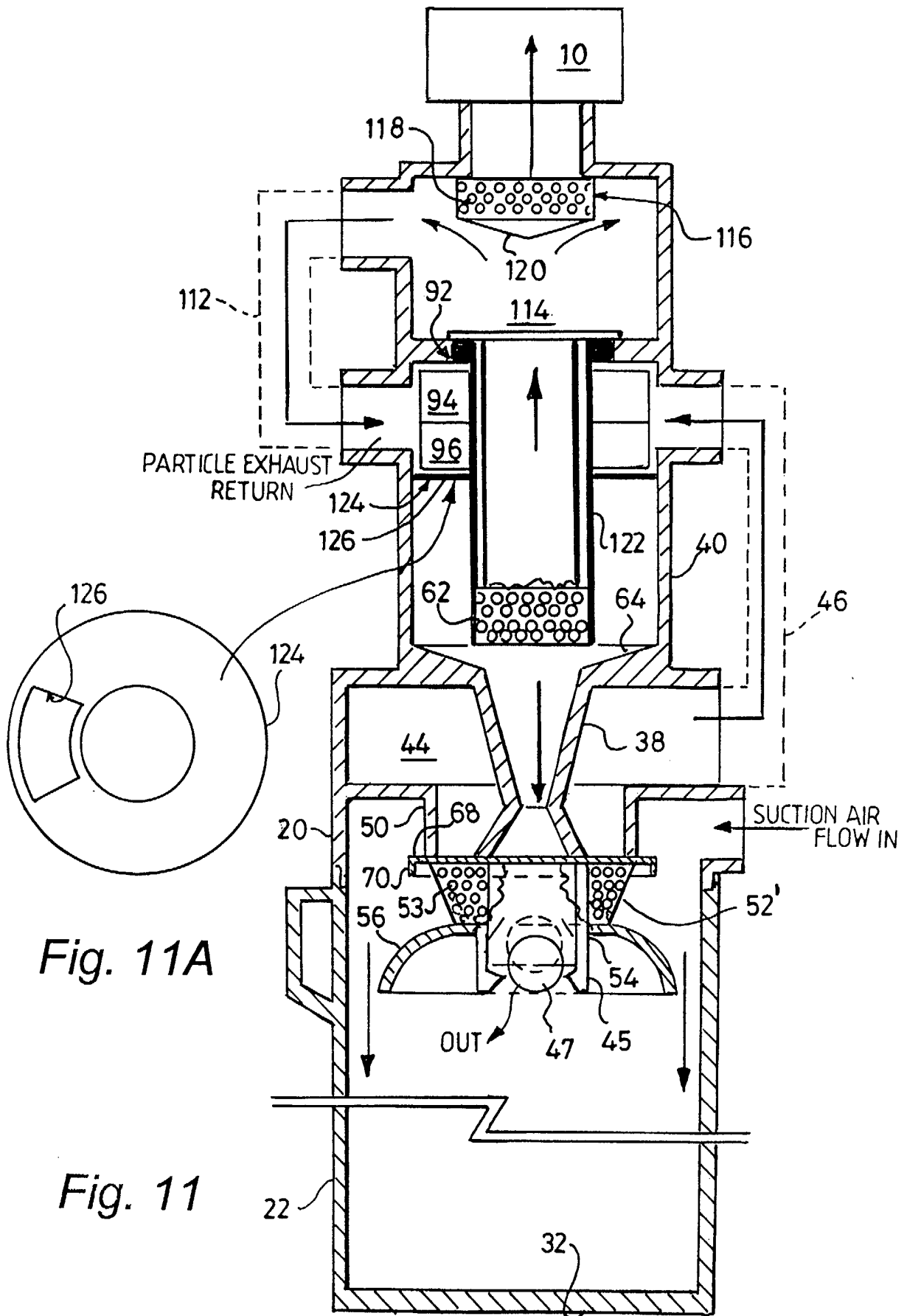

Fig. 11A

Fig. 11

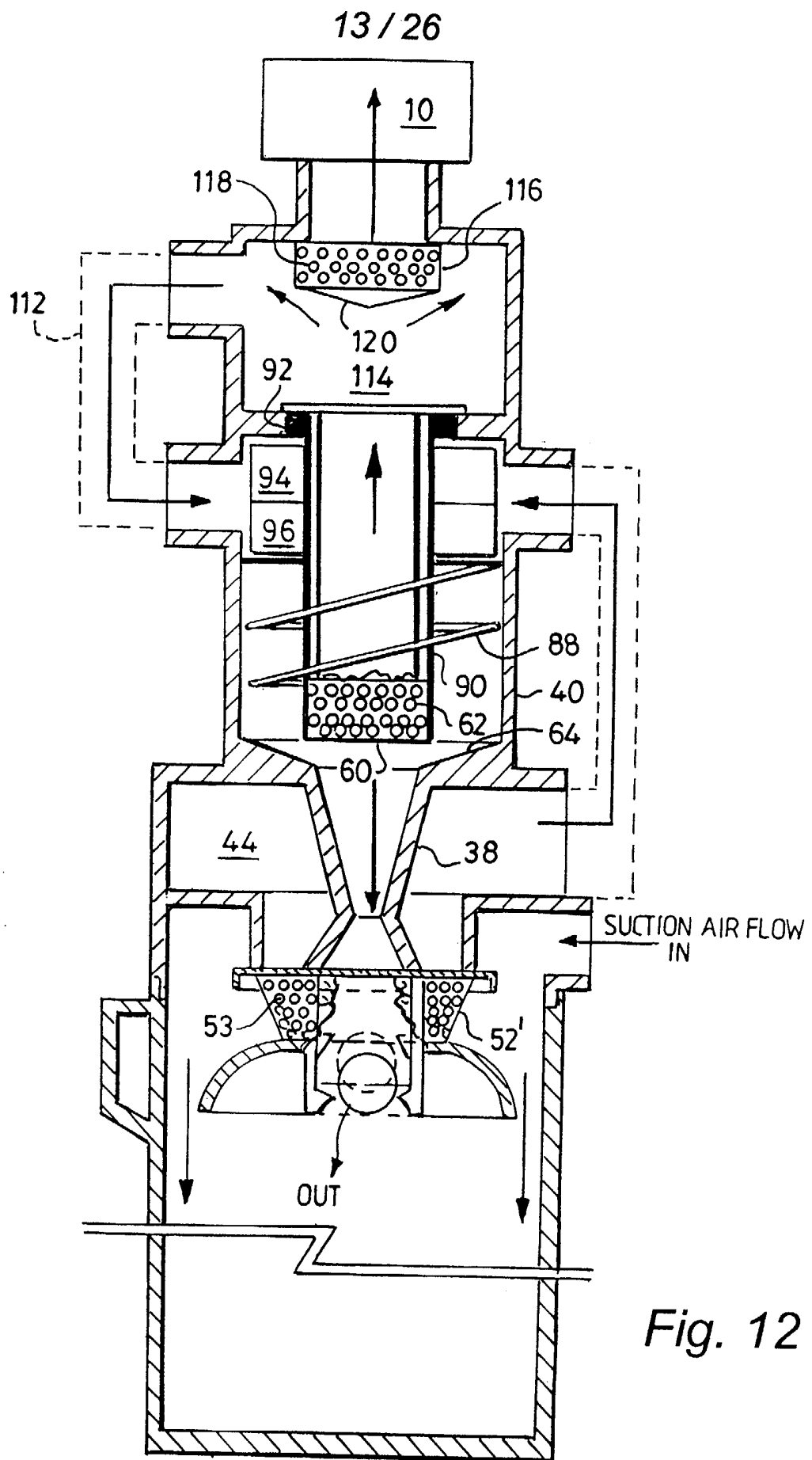

Fig. 12

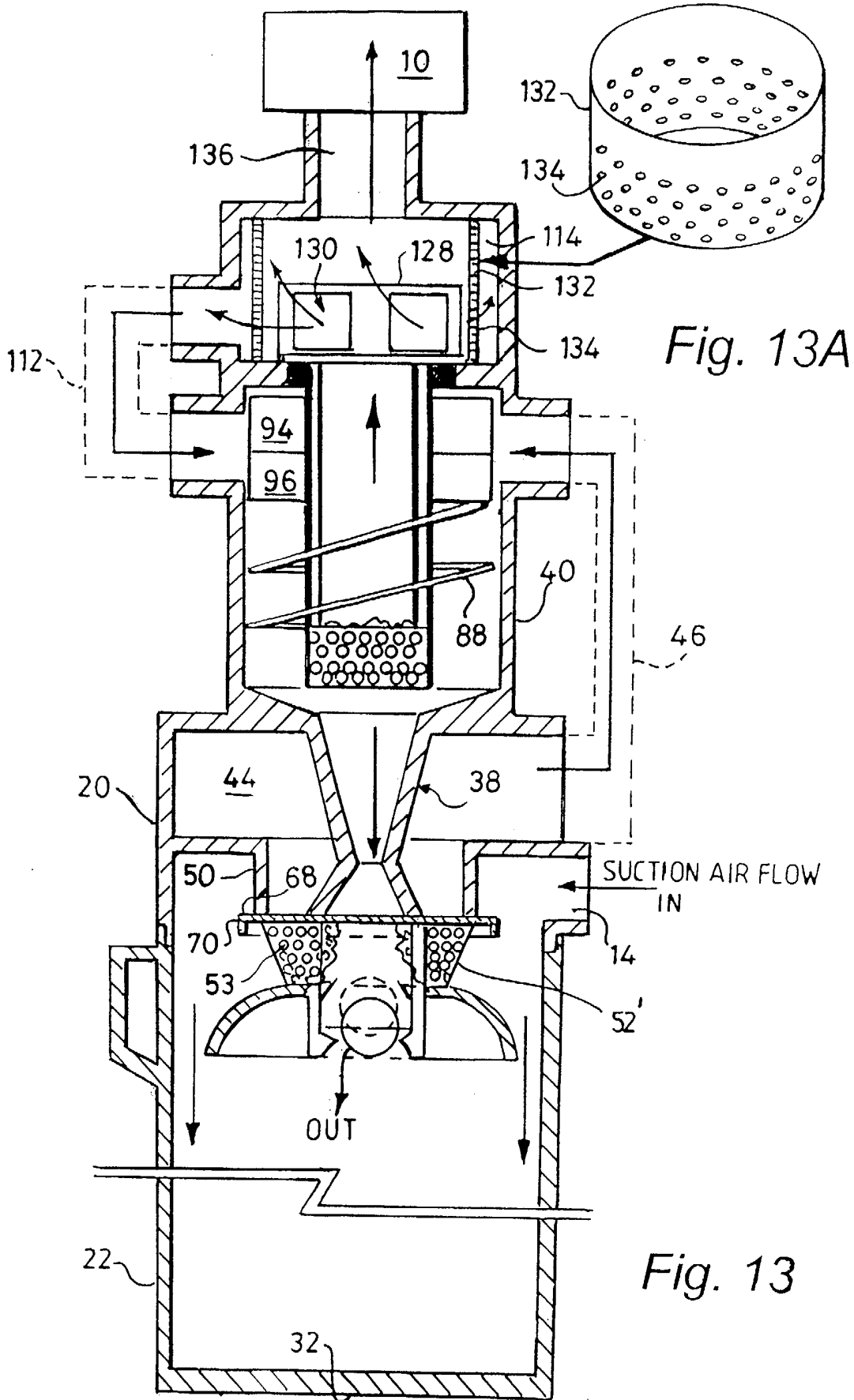

Fig. 13A

Fig. 13

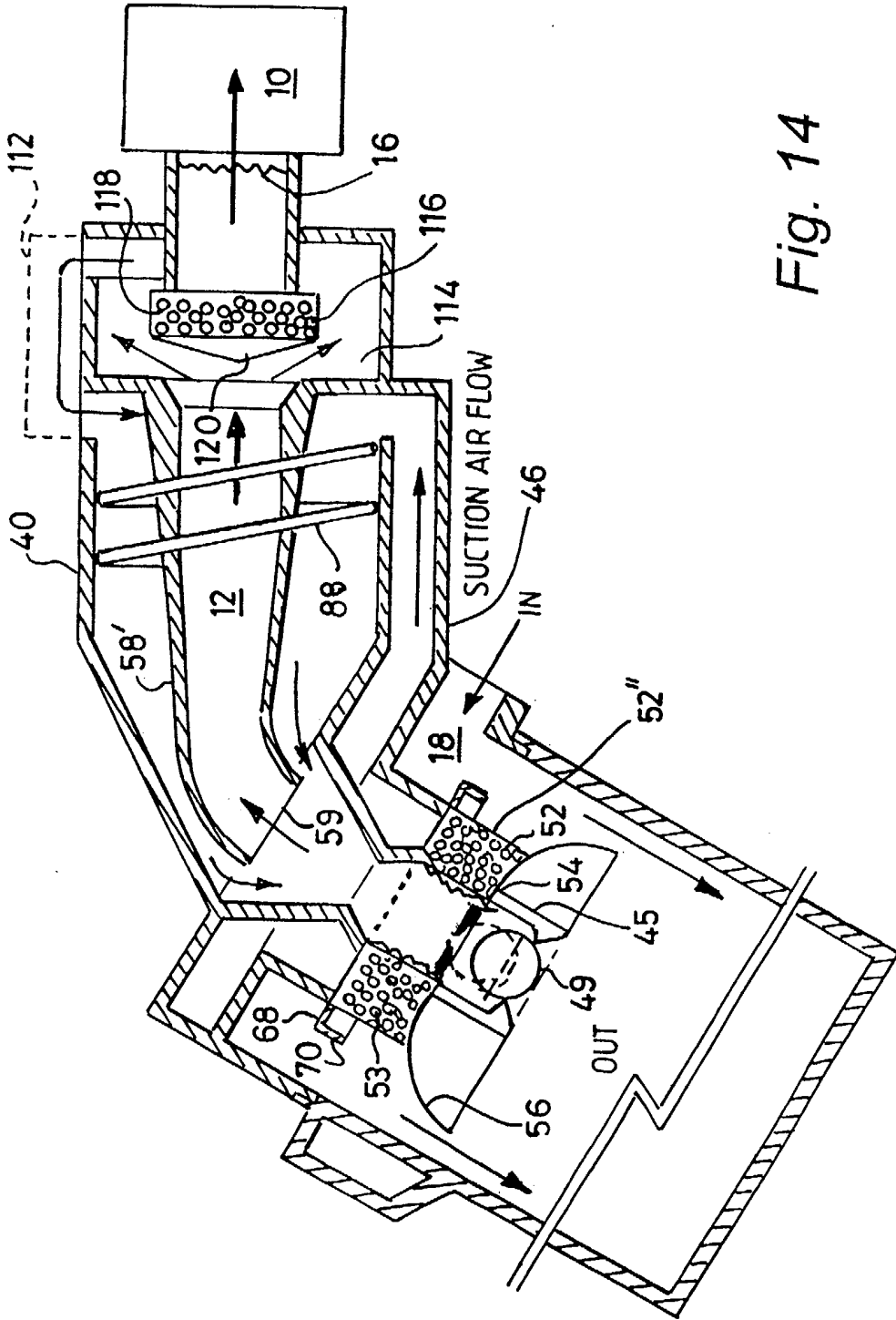

Fig. 14

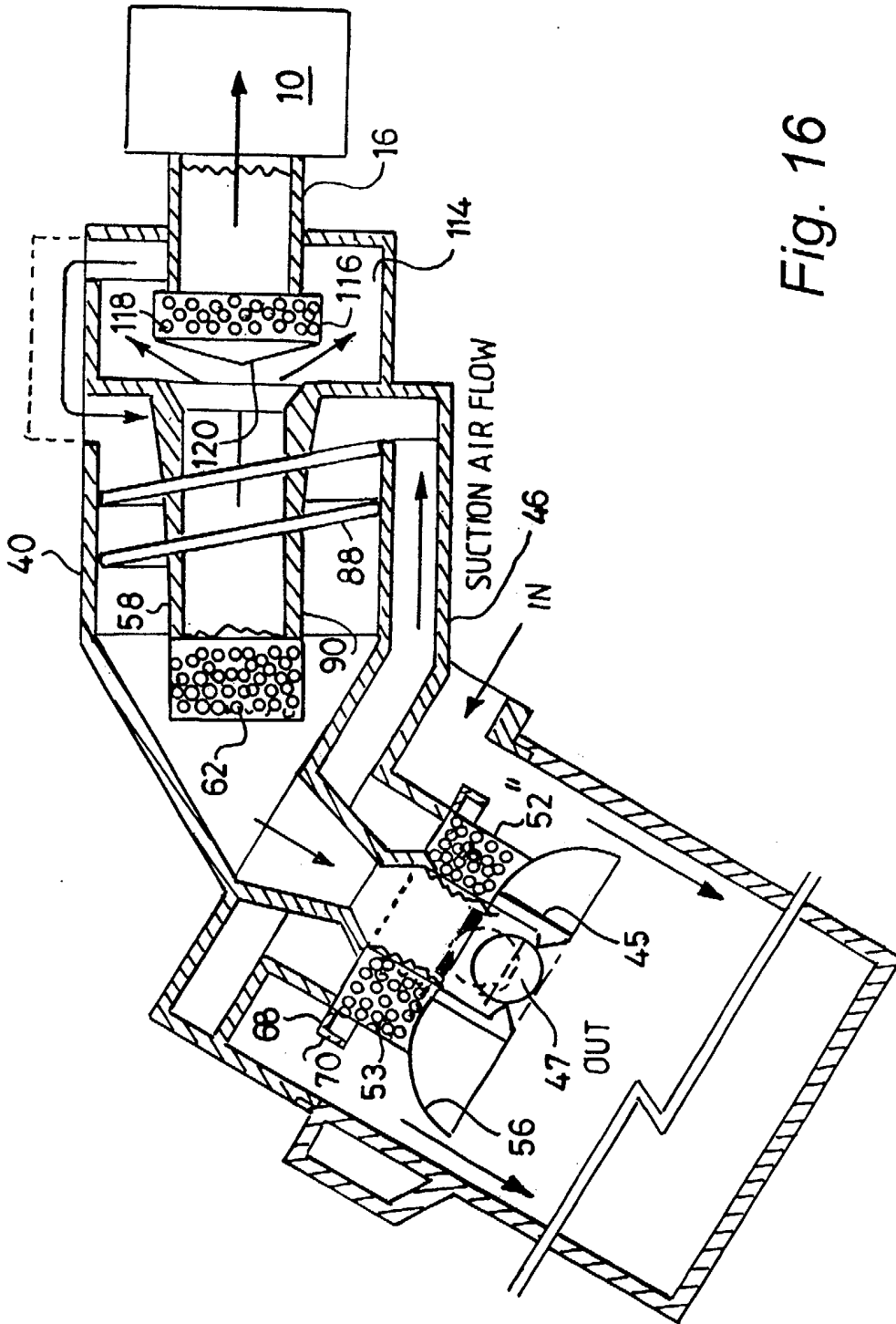
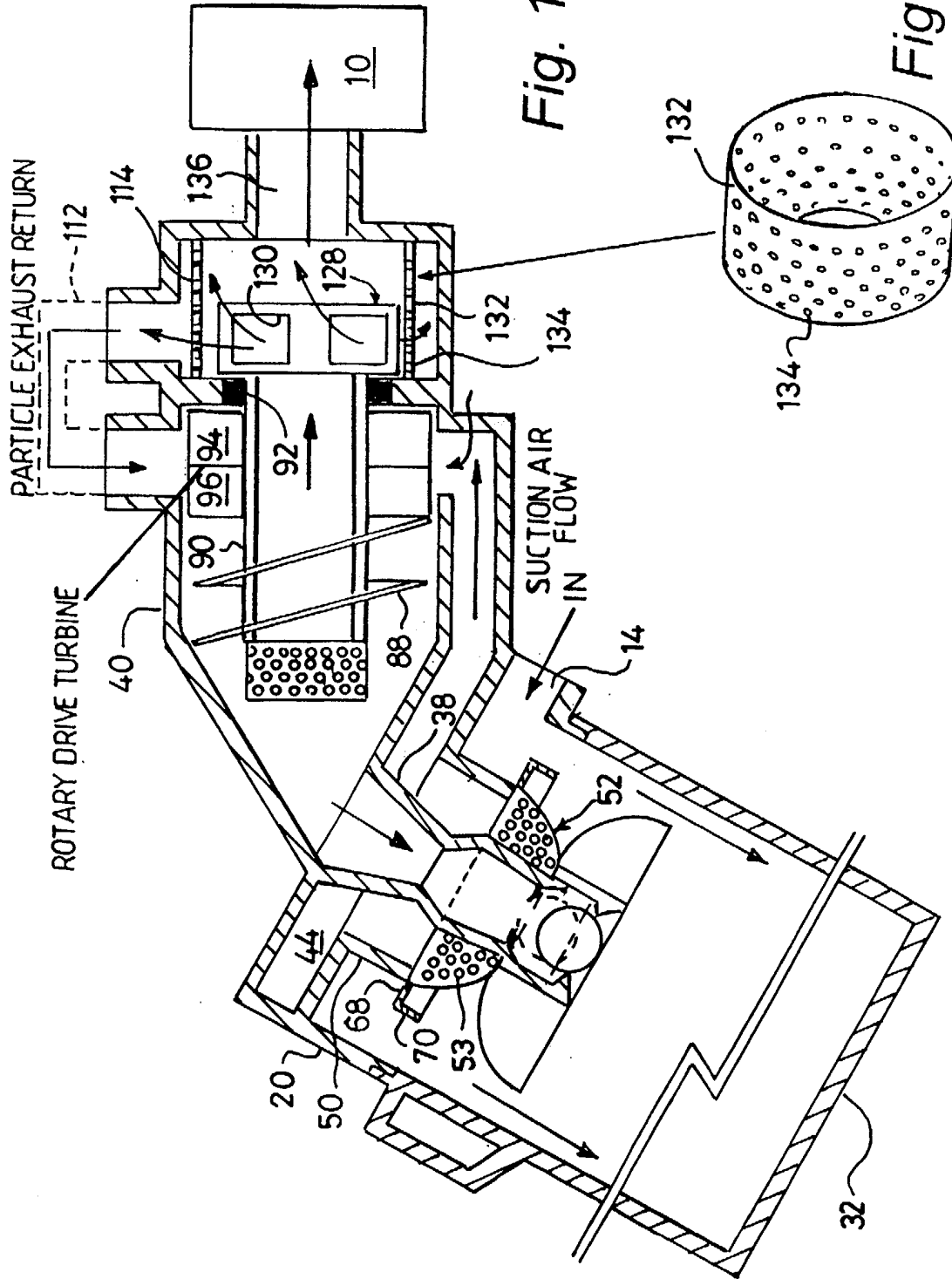

Fig. 16



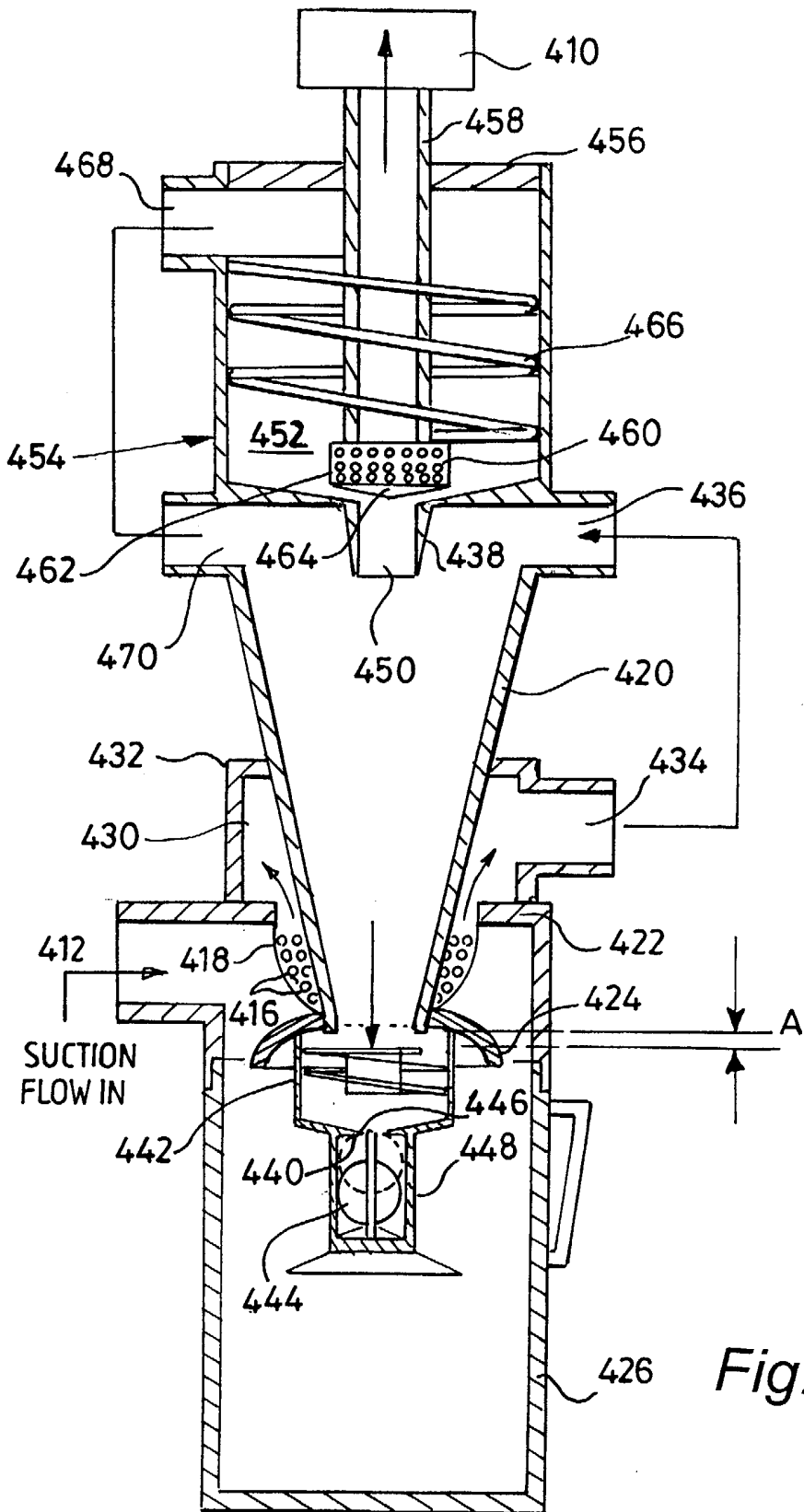

Fig. 18

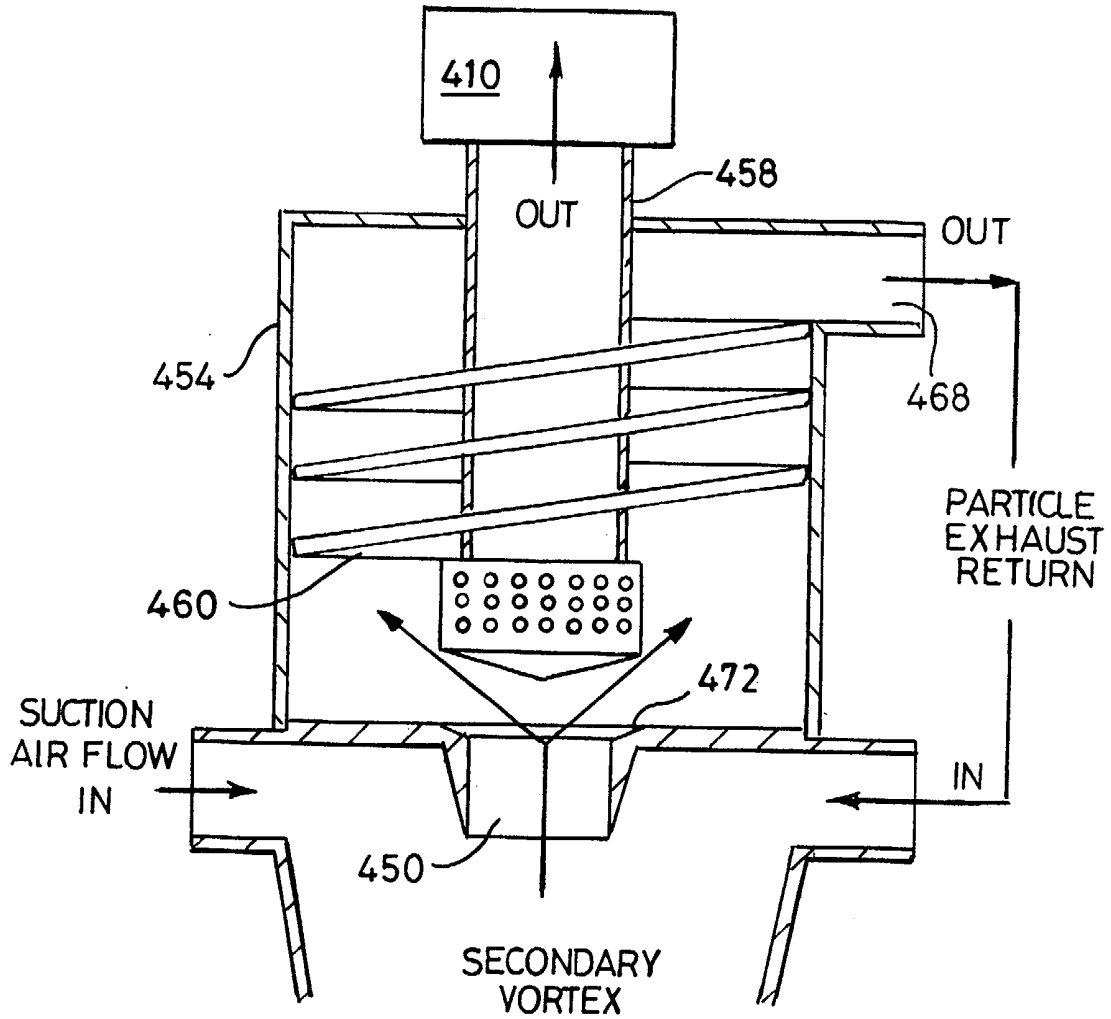

Fig. 19

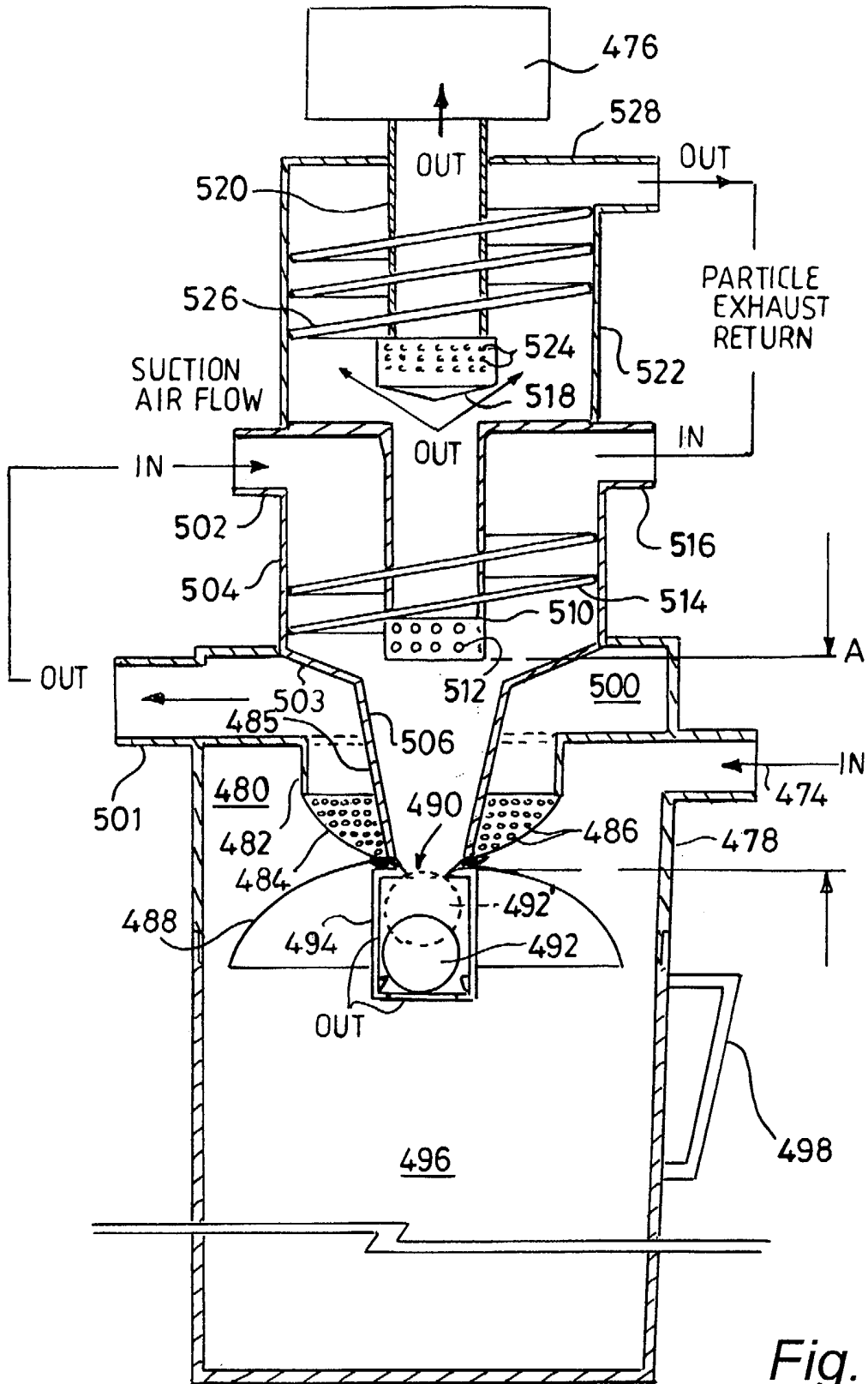

Fig. 20

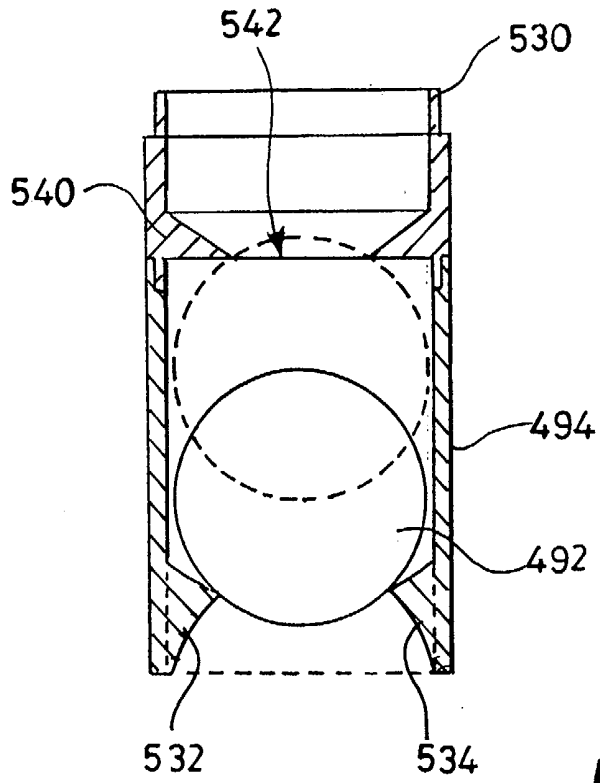

Fig. 21

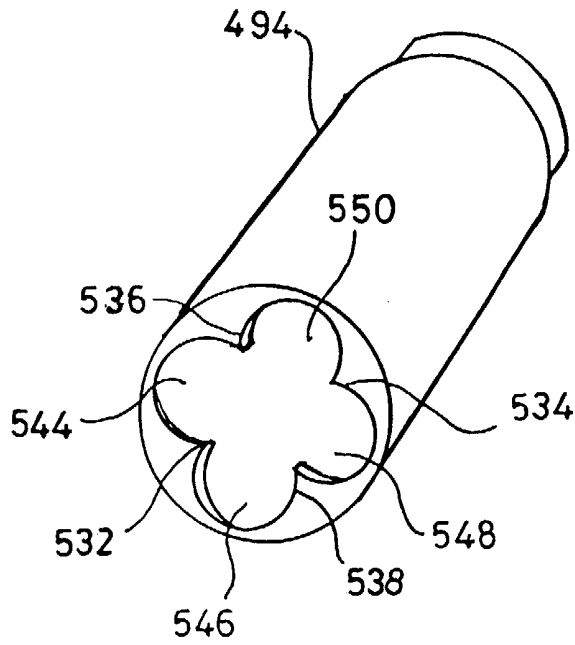

Fig. 22

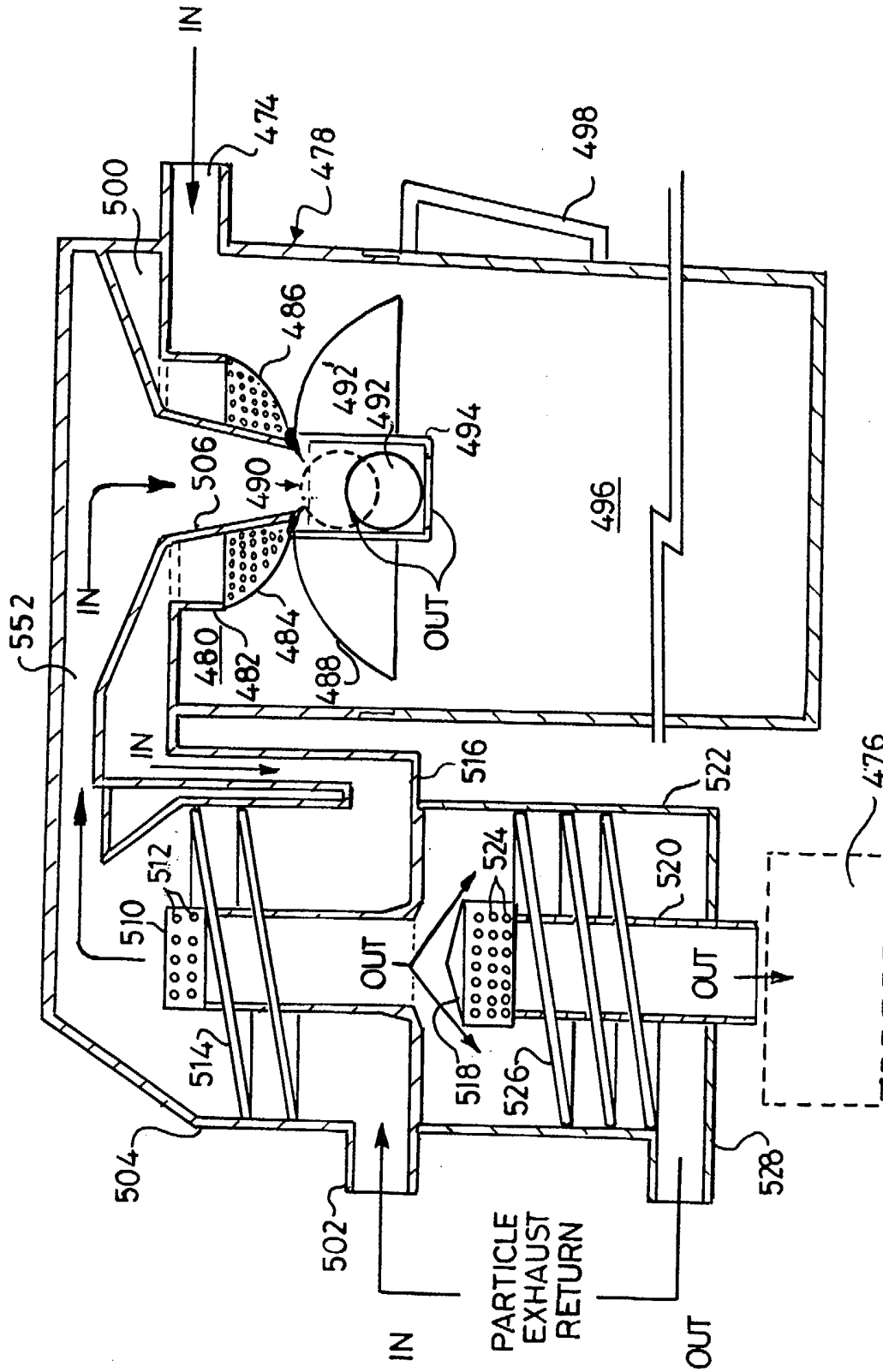

Fig. 23

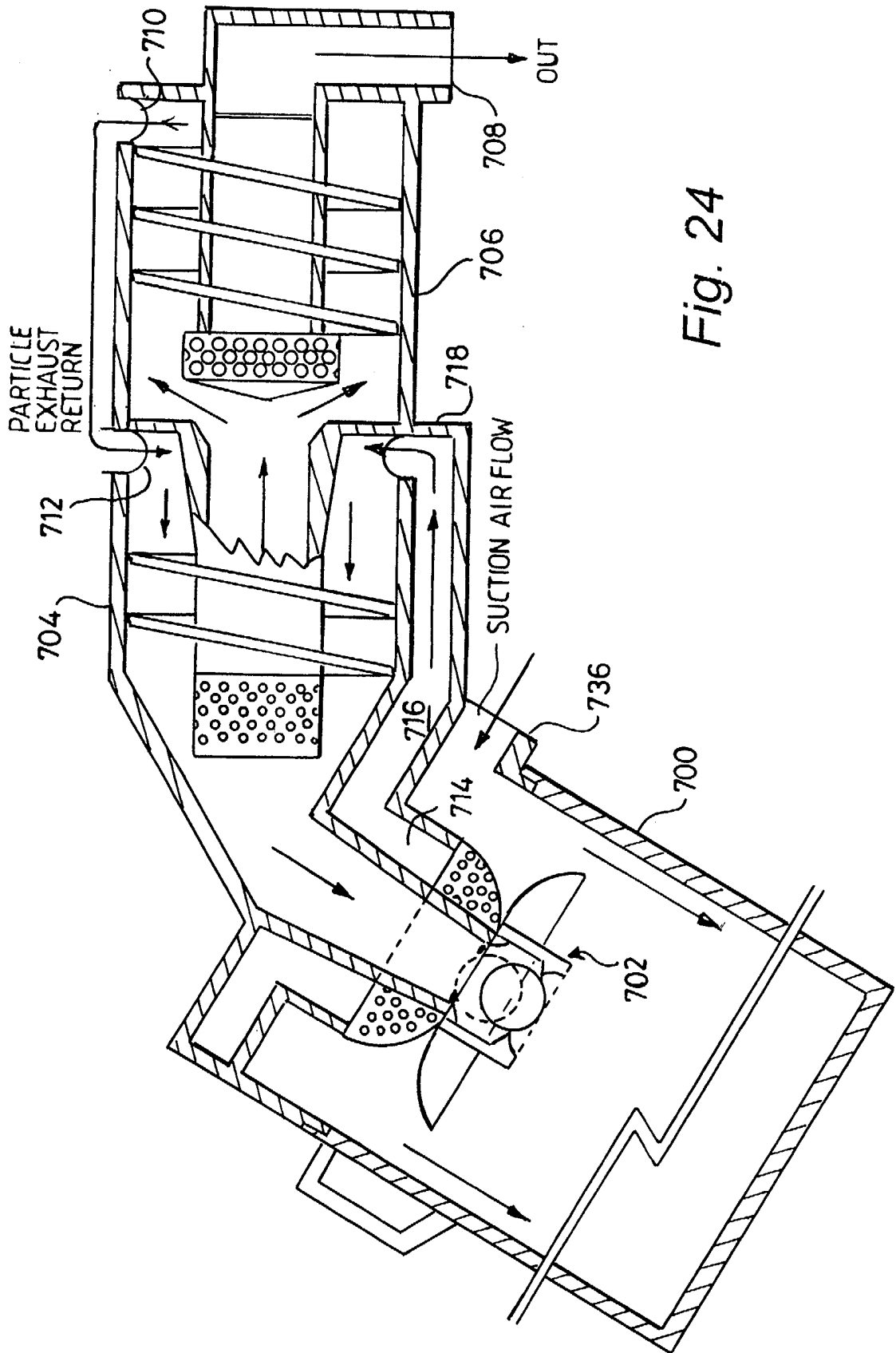

Fig. 24

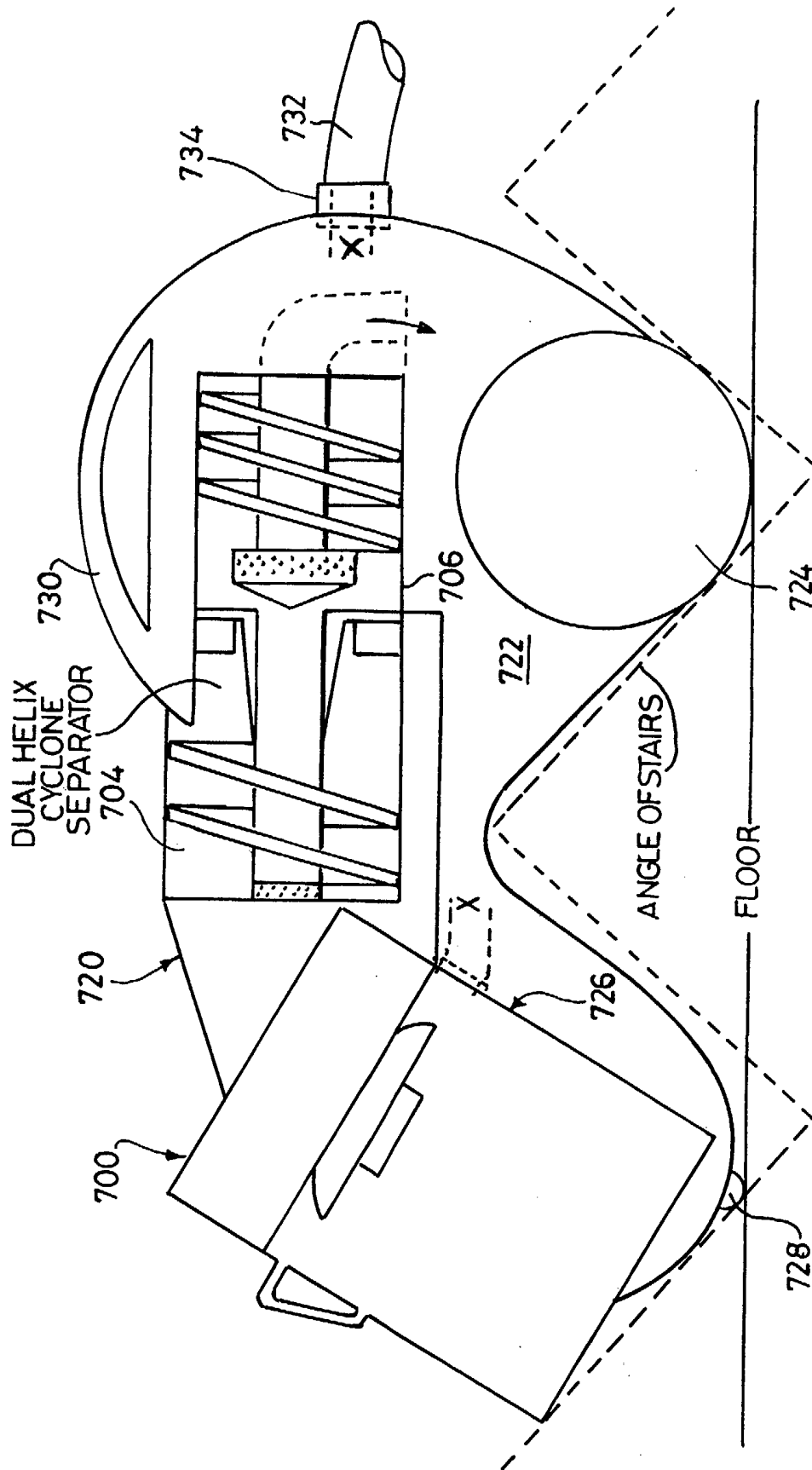

Fig. 25

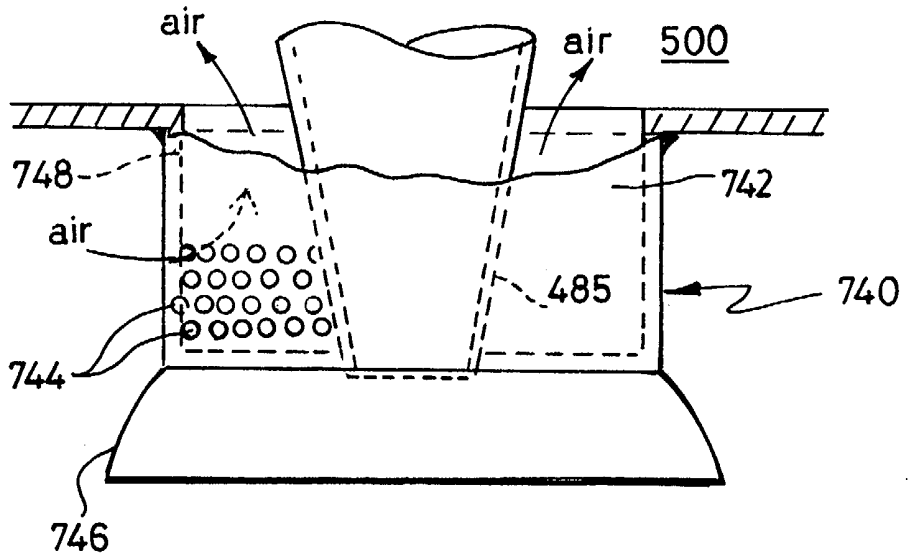

Fig. 26

C809/H

Title: Improved air/particle separator

Field of the invention

The invention concerns separators which separate one material from another based on their relative densities. In a domestic context a cyclone-based vacuum cleaner is a separator for separating dirt and dust particles from air. Similar devices are employed in industrial and commercial processes, in laboratories and in clinical and hospital environments for separating particulate material from fluids – normally air or gaseous mixture; or particulate material for liquids. In particular, but not exclusively the invention is applicable to vacuum cleaners in which one or more cyclones are set up within the apparatus for the purpose of efficiently separating dust and dirt particles from an incoming airstream.

Background to the invention

Various designs of vacuum cleaner have been developed over the years. The conventional cleaner draws dust laden air through a cloth or paper container in which all particles larger than the pore size of the material forming the wall of the container, will be retained.

Finer particles will pass through the porous wall and one or more filters are provided prior to the source of vacuum (usually an electrically powered motor driven fan or turbine), to trap these fine particles and prevent them being recirculated into the environment from which they have been removed by suction in the first place.

These filters will eventually become clogged and have to be cleaned and/or replaced. Long before that stage is reached however, the partial clogging of the filter(s) will reduce the airflow therethrough and thereby reduce the suction and the ability of the cleaner to

collect larger particles of dirt/dust particularly when deeply embedded in carpets and the like.

Objects of the invention

It is an object of the present invention to provide a more efficient means for separating fine particles from an airstream in a vacuum based particle suspension system.

It is a second object of the invention to provide a particle separation system in which the particle removal from the airstream is such as to significantly extend the useful life of the final filter normally provided before the suction producing electric motor driven fan.

Definition

In the following text and in the claims (except where the context does not admit) references to air are to be construed to mean any fluid whether gaseous or liquid and particles to mean any particulate or fibre like material which has a greater density than that of the fluid.

Summary of the invention

According to one aspect of the present invention, a method of separating particles from an airstream which is established by suction and which has already undergone at least one earlier particle separation step, involves:

- (1) introducing the airstream in a generally axial sense into a generally cylindrical chamber having two exits for air to leave the chamber, a first which preferentially exits particle-free air in a direction towards the suction source, and a second for returning particles to an earlier separation stage;
- (2) radially deflecting the incoming air on entry;

- (3) constraining the air to follow a helical path before it can leave via the second exit, and
- (4) forcing the air to change its general direction of movement in the chamber before it can leave via the first exit.

In the foregoing method the axis of the chamber may be generally vertical and the movement of the air in the chamber is in a generally upward sense, whereby particles entrained in the airflow will tend to be elevated into and follow the helical path and leave via the second exit for recirculation to the earlier separation stage.

According to another aspect of the present invention, there is provided a multi-stage air/particle separator in which the final stage comprises:

- (1) a generally cylindrical chamber provided with a central aperture at one end through which particle laden air from an earlier separation stage is introduced into the chamber;
- (2) an air deflector adapted to radially deflect incoming air in a radially outward sense towards the internal wall of the chamber;
- (3) a first exit for air from the chamber, located centrally of the chamber so that radially deflected air has to change its direction of flow within the chamber to exit via the first exit;
- (4) a second exit, located remote from the first, and separated therefrom by a baffle which defines a helical path through the chamber leading to the second exit;
- (5) a first passage for connecting the first exit to a suction source, and a second passage for returning particles to an earlier separation stage of the apparatus.

Typically the second exit is connected to an input to the separation stage immediately preceding the final stage.

The first exit may be provided in the wall of a tube which extends centrally of the chamber from the upper end thereof, towards the central aperture air inlet, and which has a closed lower end which is spaced from the inlet aperture.

The first exit may comprise a plurality of small apertures in the tube wall which communicate with the interior of the tube.

The air deflector preferably has a conical surface, the apex of which points towards the air inlet aperture in the said one end of the chamber.

The conical surface may be formed at or carried by the lower end of the central tube.

The baffle may comprise an annular helix situated between the central tube and the cylindrical inside of the chamber.

The second exit may comprise an opening in the wall of the chamber leading to a passage which extends generally tangentially of the chamber, and the position of the opening and the direction of the passage is such that particles leaving the helix can enter and travel therealong without change of direction.

The preceding separation stage typically comprises a vortex separator comprising a frusto-conical chamber into the large diameter end of which particle-laden air enters tangentially to form a primary vortex which as it rotates as it simultaneously travels axially of the frusto-conical chamber towards the smaller diameter end thereof, at which a secondary vortex is established which returns axially and centrally of the frusto-conical housing towards the larger diameter end thereof, which end includes a central opening through which the rising secondary vortex can pass unimpeded axially into the chamber containing the final separation stage, the change of direction from primary to secondary vortex producing a precipitation of particles from the airstream, to produce separation in the preceding stage.

In such an arrangement, preferably the central opening in the larger diameter end of the frusto-conical housing communicates directly with the central opening in the chamber of the final separation stage.

Typically one end of the cylindrical chamber of the final separation stage comprises the larger diameter end of the aforementioned frusto-conical housing of the preceding separation stage.

Typically the vortex separator forming the earlier separation stage is itself supplied with particle-laden air from a preliminary separator into which an air-particle mixture is drawn by the suction effect, and in which heavier than air particles in the incoming airstream are removed centrifugally before transfer to the inlet to the vortex separator.

Preferably the central opening in the larger diameter end of the frusto-conical housing of the preceding separation stage is surrounded by a cylindrical collar which protrudes axially of the housing and forms a vortex initiator for the airstream tangentially entering the second stage housing.

The external surface of the collar is preferably frusto-conical.

Typically the said preceding stage comprises a generally cylindrical chamber, similar to that of the final stage, but in which the airflow is in the opposite sense to that in the final stage, and wherein the inlet to the chamber for particle-laden air is at the one end thereof, and introduces the air in a tangential manner so as to produce a circulating airflow at that end of the chamber, and a central tube extends axially from that end of the chamber towards the opposite end, at which end it is formed with at least one opening which serves as an exit for air to leave the chamber to transfer to the final separation stage, and the airflow in the chamber of the said earlier stage is forced to follow a helical path axially of the chamber due to the presence of an annular helical baffle located between the exterior of the central tube and the inside of the chamber wall between the inlet and exit ends of the chamber, and an axial extension to the chamber is provided which communicates with the

interior thereof in the region of the end of the central tube, which extension serves to collect particles precipitated from the airstream as the latter changes direction to leave via the central tube.

The helical baffle can have less than one complete turn, or between one and three turns, preferably two turns.

A second inlet may be provided at the same end of the previous stage chamber as the first mentioned inlet, to allow particle-bearing air from the final stage to be recirculated to the preceding stage chamber.

The second inlet preferably also introduces air into the earlier stage chamber in a tangential manner.

The first and second tangential inlets are preferably arranged so that both establish circulation of air in the chamber in the same sense.

Typically the second inlet is circumferentially remote from the first inlet, and conveniently the first and second inlets are 180° apart.

The final stage chamber is preferably mounted vertically above a chamber containing the said preceding separation stage, and the latter is located vertically above a preliminary centrifugal separator.

Where provided the axial extension to the said earlier stage chamber, preferably extends axially into the preliminary centrifugal separator.

The final and preceding separation stages may be situated to the side of the preliminary centrifugal separator, with the final stage located below the preceding stage, and a passage extends from the upper end of the said preceding stage chamber to convey particles separated from the airflow in the preceding stage chamber, to a particle collection region.

The passage can leave the upper end of the preceding stage chamber in a tangential manner, or in a radial manner.

The preliminary centrifugal separator is preferably located at the upper end of a particle collecting bin, and a valve may be provided, which is closed whilst suction induced airflow exists through the apparatus, but which when opened, allows particles gathered above the valve to fall into the bin, to join other particles which have entered the bin due to centrifugal separation.

Preferably particle level sensing means is provided together with a switch, whereby when the particle content of the bin reaches a given level therein, the power to the suction producing device is shut off, to stop continued operation of the apparatus until the bin is emptied, and/or an alarm signal is generated.

The switch may be a microswitch activated through a membrane type of diaphragm and located in a small housing below a cage containing a valve closure member.

Alternatively the switch may be a microswitch located to the side of the said housing with an extension of the microswitch actuator extending down below the housing, to form a lightweight paddle which is lifted as the particle content rises, until the switch is actuated.

An annular gap between an opening in the upper end of the bin and the outside of the lower end of a frusto-conical housing vortex separation stage (constituting the said preceding stage) serves as the air outlet from the primary centrifugal separation stage and the annular gap is blinded by a shell which extends from the opening in a downward sense to merge with the wall of the frusto-conical housing. The shell is typically generally cylindrical and solid walled in an upper section thereof, to form a vortex starter at the upper end of the bin, which itself is also cylindrical, and the shell is apertured below the vortex starter section to allow air to pass into the shell and up the internal annular gap to pass to the next particle separation stage of the apparatus. A radially extending annular

ridge may be provided between the upper solid walled vortex starter section of the shell and the lower apertured region, so that the rotating mass of air is forced radially outwardly before it registers with the lower apertured region, to assist in centrifugally separating particles from the air before the latter is drawn inwardly under suction to exit through the openings in the shell.

According to a particularly preferred feature of the invention an apertured cylindrical sleeve surrounds the helical baffle in the final stage.

Where such a sleeve is provided an annular region exists around the sleeve, between it and the cylindrical wall of the final stage chamber, into which heavier than air particles will tend to pass through the apertures in the sleeve, for return to an earlier separation stage.

The invention will now be described by way of example, with reference to the accompanying drawings, in which:

Figs 1-17 illustrate a variety of different multi-stage cyclone air/particle separators, some of which embody the invention; and in which:

Figure 18 is a cross-sectional elevation of a three stage separator, the third stage of which embodies the invention;

Figure 19 is an enlarged section through the third stage, showing minor alterations to the structure which may be incorporated;

Figure 20 is a cross-sectional elevation of another three stage separator embodying the invention;

Figure 21 is a cross-sectional elevation of a ball-valve assembly of the type shown in Figures 20;

Figure 22 is a perspective view from the lower end of the ball valve enclosure of Figure 21;

Figure 23 is a cross-section elevation of a further three stage separator embodying the invention, to which the final and preceding stages are arranged one above the other to the side of a centrifugal preliminary stage, and particle collecting bin;

Figure 24 is a side elevation schematic of a vacuum separator system suitable for fitting within a cylinder-type domestic vacuum cleaner which is adapted for resting on the treads of a staircase as well as a horizontal flow;

Figure 25 is a side elevation showing how the component parts of Figure 7 can be fitted within the typical housing of such a vacuum cleaner; and

Figure 26 is an elevation of an alternative construction of air flow initiator and shroud for use in the preliminary separation stage of a device such as shown in Figure 3, 6 or 7.

In Fig 1 an electric motor driven fan or turbine 10 provides a source of suction at the upper end of passage 12 to draw air through the different stages of the apparatus, as will be described, from an inlet passage 14.

In the case of a domestic or commercial vacuum cleaner 14 will be connected to a hose (not shown) having a dust collecting head of known design (not shown) at its far end. The last part of the hose may in known manner be rigid.

In the case of a device for separating particles from air from apparatus such as in a laboratory or industrial or commercial environment, the inlet 14 will be connected to the enclosure from which dust/particle laden air is to be extracted.

A filter 16 (which may be removable for cleaning or replacement) may be located immediately prior to the suction source 10, although in some embodiments this may be

dispensed with in view of the very high efficiency of such embodiments at removing particles from the incoming air.

The inlet passage 14 introduces air into the upper end 18 of a two part cylindrical chamber 20, 22, sealingly joined at 24 but separable to allow particles collected from the airstream to be emptied.

Particles are collected from a first separation step (which occurs within 20, 22) in the annular space 26 at the lower end of 22 formed by a central hollow frusto-conical housing 28 which extends centrally of 20, 22 to sealingly engage around a circular platform 30 upstanding from the flat, closed end 32 of 22. The space within 28 serves as a second particle-collecting region, for retaining particles separated from the airflow by a second separation step (to be described).

The upper end of 20 is closed at 34 but includes a central circular opening 36 through which a frusto-conical extension 38 of a second cylindrical chamber 40 can pass in a downward manner. An annular space 42 between the wall of the opening 36 and the extension 38 allows air to leave 20, 22 and pass into an annular manifold 44 from which it can pass via a passage (shown dotted at 46) to an inlet port 48 at the upper end of the chamber 40.

Inlet 48 introduces air into the interior of 40 in a tangential manner in a similar way to that in which 14 introduces air into the region at the upper end of 20, 22.

Centrally of 18, a collar 50 extends axially down onto 20, the interior of the collar communicating with the opening 36 in the end 34 of 20. The collar is generally cylindrical and terminates in a part hemispherical dome 52 which extends down to and surrounds the frusto-conical extension 38, where it is sealingly joined at 54. A skirt 56 which is also generally part hemispherical and open at its lower end, extends from the join 54.

The dome 52 is perforated by a large number of very small holes 53. The skirt is non-perforated.

In operation, the incoming tangential rush of air through 18 sets up a rotating mass of air around 50 which can only exit via holes 53, which are axially displaced from the region into which the air is introduced. This causes the rotating mass of air to migrate axially as it rotates, so setting up a so-called vortex flow within 20, 22 and heavier than air particles will be flung towards the cylindrical wall of the chamber 20. The particles will axially migrate with the vortex and once in a downwardly spiralling trajectory will tend to continue in that manner axially down the chamber 20, 22 through the annular gap between the skirt 56 and the interior of 22.

Once the particles are below the skirt 56, there is little tendency for them to migrate back up the chamber, even if turbulence exists below the skirt, and they will tend to congregate in the annular region 26.

Thus although air entering at 18 may be laden with heavier than air particles (dust, hairs, grit and the like in the case of a vacuum cleaner), muck of these particles will be separated from the air before it passes through the openings 53 in the inverted dome structure 52. Therefore the air passing up through 42 and via 44, 46 and 48 into the upper end of the second separation stage, will be substantially depleted of particles, relative to that entering at 14.

As mentioned earlier, suction is applied to the upper end of passage 12, which is formed by a hollow generally cylindrical housing 58 which extends axially of the cylindrical chamber 40 to terminate near its lower end.

The lower end of housing 58 is closed at 60 but around that closed end, the wall of 58 is perforated with a large number of small holes 62, so that suction applied at 12 will cause air from within 40 to be sucked into the interior of 58 to pass axially therethrough in an upward sense.

This suction causes air to be drawn in through 48 from 44 so establishing the airflow through the chambers and passage 46, from inlet 14 to the suction device 10. The latter includes an outlet through which air, removed from the apparatus can exit to the atmosphere.

The external surface of the upper end of housing 58 is frusto-conical, and in combination with the tangential inflow of air, creates a rotating mass of air around the housing 58, which, since it must pass axially down the housing 40 before it can leave via holes 62, becomes a vortex which accelerates as it reaches the lower end of the cylindrical region of 40 due to a sudden frusto-conical reduction in the internal cross-section of 40, as denoted by 64. The acceleration increases the centrifugal forces on any heavier than air particles relative to the air molecules, so causing any such particles to carry on spiralling downwardly accelerating as they do due to the frusto-conical cross-section of the interior of extension 38 of the chamber 40.

The particles spiral down into the interior 66 of the housing 28, where they tend to remain.

If the airflow through 40 is high enough, the rotating and axially descending vortex of air may substantially bypass the openings 62 in the wall of 58 and continue to spiral downwards carrying the particles in the spiralling airstream. At some point the effect of the closed end 30 and the enlarging cross-section of housing 28 will cause the rotating mass of air to invert and begin ascending centrally of the downward spiral of air passing through 38 and 28, but in order to do so, the sudden deceleration and acceleration of the air molecules as they change direction, will in general be too sudden to allow heavier than air particles present in the airstream, to follow the same tortuous path as the air does, and such particles will become separated from the airstream and remain trapped in 28.

The two stages of separation so achieved, result in substantially all heavier than air particles remaining in 26 or 28 and largely particle-free air passing out through 12 and 10.

An improved separation can be achieved in the first stage by providing an annular flange 68 around the collar 50 at the junction between the perforated and unperforated wall sections. This serves to accelerate the rotating mass of air just before it reaches the perforated region 52, thereby forcing any heavier than air particles to migrate radially even further from the collar.

The effect is further enhanced by extending the periphery of the flange 68 in an axial manner to form a cylindrical lip 70 which extends in the direction of movement of the vortex in the chamber 20, 22.

Typically the diameter of the collar 50 is in the range of 5-8 cm and the radial extent of the flange will be of the order of 1cm and the lip can extend axially from the flange by a similar distance of the order of 1cm.

The separator may be used to separate particles from air which also contains liquid droplets such as water. The presence of the flange 68 and lip 70 reduces the risk of liquid droplets from being entrained in the air exiting via holes 52, since they, like any heavier than air particles, will be forced to adopt a high rotational speed to pass around flange 68 and will therefore be even further removed by centrifugal force from the inner regions of the chamber 20, 22.

Fig 2 illustrates an alternative 2-stage separator in which air flow is established in a similar way as in Fig 1 from inlet 14 to suction device 10, and the same reference numerals are employed to denote parts which are common to the two arrangements.

The main operational difference is the shortening of the length of housing 58 and the removal of the closed end 60 and apertures 62. The lower end of 58 is now open at 59.

Secondly the frusto-conical extension 38 of housing 40 now converges more sharply to define a small diameter neck 39 below which the extension reverses the frusto-conical configuration to form a trumpet-like end 41 which terminates in a cylindrical region 43.

From below 43 (although not shown as such) the 2-bin configuration of Fig 1 may be employed, so that particles from 43 drop into a region 66 and those from around the skirt 56 into an annular region 26. As shown, a single bin or valve may be employed. Thus as shown, the lower end of 43 is formed as a cage 45 for a light weight ball 47, which when airflow is established, is drawn up to close off the lower end of 43 (as shown in dotted outline), the junction between 43 and 45 being of reduced diameter to form a valve seating. The lower end of 45 is partially obstructed to retain the ball.

A microswitch 72 is also shown in Fig 2 having an actuator arm 74, such that when particulate material in the chamber 20, 22 becomes high enough to lift the arm 74, the switch is operated and an alarm is initiated (audible or visible or both), (not shown) and/or power to the suction source 10 (e.g. current to the fan motor) is cut off to prevent further operation until the chamber 20, 22 has been emptied.

The level detecting switch may be fitted to the Fig 1 embodiment if desired, and one may be located in the space 66 and another in the space 26, or one in the space that, from experience, always fills up first. In general this will be the annular region 26.

Better separation in the chamber 40 is achieved if the housing 58 is extended and tapered to protrude into the upper end of 38 as shown at 58' in Fig 2A.

Fig 3 illustrates a further alternative 2-stage separator similar to Fig 1 (and to that end the same reference numerals have been employed as appropriate), in which a valve has been incorporated, as in Fig 2, but in which a different type of valve is shown from that shown in Fig 2. The valve is shown in more detail in Fig 4, and comprises a conical poppet 74 at the lower end of a spindle 76 at the upper end of which is a cup 78. A valve seating 80 retains an O-ring 82 against which the conical surface of the poppet 74 is forced, to close the valve once airflow has been established through the apparatus. The spindle 76 extends through the poppet and is slidingly received in a guide 82 in a cross member 84 which extends across the open lower end of the housing 45. The cross member 84 and guide 82 are shown in the scrap view of Fig 4A.

Particles can pass down through the open end of tube 38 during operation, and remain above the poppet 74 until airflow ceases, whereupon the poppet drops and particles can fall past the conical surface of the poppet and around the cross member 84, into the common bin 22.

A spring (not shown) may be fitted between the conical surface 74 and the upper end of the enclosure 86, (or between the cup 78 and the end 86) so that as soon as airflow drops, the poppet valve opens under the action of the spring.

Fig 5 shows an arrangement that is similar to that of Fig 1 (and similar reference numerals have been employed throughout to denote similar components). Particles are collected in two bins as in Fig 1, so there is no need for a valve such as shown in Figs 2 to 4, although it is to be understood that mixing of the separated particles in bin 66 with air circulating in the frusto-conical vortex separation stage 38 is better prevented if a valve were to be provided between 38 and 66.

The main difference between Figs 5 and 1 is the provision of a helical baffle 88 around the central hollow member 58 in the second separation stage housed in chamber 40. This prevents air entering the chamber 40 from passing in a straight line to the openings 62 at the lower end of 58 and forces the airstream to continue to describe a circular route (albeit while progressing axially via the turns of the helix). This introduces centrifugal forces on the rotating air mass and thereby on heavier than air particles in that airstream, which will therefore migrate to the radially outer regions of the helical path followed by the airstream, and will be less likely to be caught up in the radially inward flow of air through the openings 62 to enable it to exit the chamber under the suction force from 10.

Fig 6 shows a variation on Fig 2 in which the lower end 60 of tube 58 (in the second stage) is closed off and the exit for the air from the chamber 40 is provided by a large number of small openings 62 in the wall of the tube, as provided in the embodiment shown in Figs 1 and 5. The arrangement benefits from the simplicity of the single particle collecting bin but

therefore requires the addition of a valve as described in relation to Fig 2 and a level sensing microswitch 72 is also shown associated with the bin.

Fig 7 shows how the helical baffle of Fig 5 can be combined with the simplicity of the single bin and the improved second stage separation associated with the necked frusto-conical vortex separation chamber 38, 41 described in relation to Fig 2, to achieve a further overall improvement in particle separation for a given airflow and particle size distribution. As before items which are common to earlier embodiments are identified by the same reference numerals as have been employed in earlier figures.

Figs 8 and 9 show how the designs of Figs 6 and 7 respectively can be modified to further improve separation in the second stage. In each case the stationary tube 58 is replaced by a rotatable tube 90 supported for rotation about its central axis by a bearing 92 in the upper end wall of the housing 40. Situated in general alignment with the air inlet 48 and fixed to the tube 90 is a two element turbine 94, 96 (although it is to be understood that a single turbine element such as 94 or 96 may be used in place of the two element arrangement). Where two elements are employed the one is mounted with its blades out of phase relative to those in the other, so as to effectively double the number of turbine blades on which the incoming airstream acts. This increases the speed of rotation.

Being attached to 90, the rotation of the turbine(s) causes 90 to rotate. Air entering the chamber is also forced to rotate with the turbine(s) before it can begin its passage down the interior of chamber 40 to exit via openings 62 in the wall of the tube 90. The rotation of the tube 90 will also help to keep air near the surface of the tube rotating in a similar manner, so that centrifugal forces will be active in heavier than air particles in the suction induced airflow through the chamber 40 as the latter migrates down the chamber.

This in turn assists in separating remaining in the airstream, from the air, which latter changes direction near the bottom of the chamber to exit, virtually particle-free, through the openings 62. Separated particles continue to rotate around the chamber close to the wall thereof, until they are accelerated by the radially reducing regions of 64 and 38 where

they progress through via the valve arrangement into the common bin 22, as previously described.

The arrangement of Fig 9 differs from that of Fig 8 by the inclusion of the helical baffle 88 which is attached to the rotatable tube 90 similarly to the manner in which it is attached to the stationary tube 58. However, as the tube 90 rotates the helical baffle will similarly rotate and perform somewhat like a screw-conveyor and continue to rotate as well as axially move the incoming air and particles through the chamber 40.

In practice the separation efficiency of the Fig 9 embodiment is somewhat better than that of the Fig 8 embodiment.

Although not shown a level-sensing switch such as 72, 74 can also be employed in the arrangements shown in Figs 5, 6, 8 or 9.

Fig 8 also demonstrates diagrammatically how the necked form of vortex tube such as shown in Fig 2 may be used in place of the simple frusto-conical tube shown in Fig 1, and it is to be understood that either form of tube may be employed in the second stage of any of the different embodiments shown in the drawings.

A further improvement in separation efficiency, but which does not involve rotating parts, is shown in Fig 10. This embodiment incorporates a third separation stage in an extension 92 of the chamber 40. This arrangement is based on the arrangement shown in Fig 7 in which the central hollow tube 58 extends axially of the chamber 40 and carries a helical baffle 88. The upper end of the chamber 40 is closed by a wall 94 from which the tube 58 extends, the wall being apertured to communicate with the interior of the tube 58, so that (as in Fig 7) air entering 58 can pass axially up the interior 12 to enter the suction producing device 10.

In the Fig 10 embodiment, the airflow leaving the upper end of the tube 58 now enters the chamber 96 (within the extension 92) and centrally of the chamber extends an elongate

cylindrical member 98 the lower end of which is conically shaped at 100 with the apex of the cone pointing towards the incoming airflow from 58. The angle of the cone and the diameter of 98 are selected so as to cause the incoming air to be radially deflected so that any heavier than air particles in the airflow will tend to be displaced radially outwardly as well.

Around the member 98 is a helical baffle 102, which as shown is oppositely handed relative to the baffle 88.

The suction source 10 communicates with the upper end of chamber 96 via opening 104 so that air entering 96 from 58 in general has to pass up the helical path defined by the helical baffle 102, before it can exit via 104 to 10. In so doing, the rotation imparted to the ascending mass of air will cause heavier than air particles to migrate to the radially outer regions of the turns of the helix.

Surrounding the helix is a cylindrical shroud 106 having a large number of small openings 108 through which air and particles can pass into the annular region 110 between the shroud 106 and the inside surface of the wall of the chamber 92.

A return path for particle bearing air from this annular space is provided via a passage 112 to exit tangentially into the upper region of the chamber 40 generally opposite the tangential entrance 48 by which particle bearing air from the first stage enters, the airflow from 112 entering the rotating air flow (created by the inflow through 48) in the same direction as it is rotating in 40.

Particles which pass through the holes 108 will tend not to return through them, so that once separated from the rotating airstream in the helix within the shroud, the particles will tend to migrate via passage 112 to mix with the particles at the top of 40, where they will tend to be separated by the action of the vortex established in 40 as previously described.

The central member 98 is secured to the helix 102, which in turn is secured within the shroud 106, which in turn is secured at opposite ends to the top and bottom of the extension 92.

Figs 11, 12 and 13 show how turbine arrangements of Figs 8 and 9 can be modified to supply air and any remaining particles to a third stage separation unit which may be similar to what is shown in Fig 10, or may be a simple cavity 114 having a return path 112 as described in relation to Fig 10 with a central hollow deflecting collector 116 comprising a cylindrical shell 118 having a large number of small openings in the wall thereof and a conical closed lower end 120 which acts in the same way as the conical lower end 100 of the central member 98 in Fig 10.

In Figs 11-13 the perforated hemispherical shell 52 of the previous embodiments is now shown as a hollow frusto-conical shell 52' also formed with perforations 53 through which air and small particles can pass. In common with the hemispherical shell 52, the size of the openings formed by the perforations in the shell wall is selected so as to generally impede particles greater than a given size, to prevent them from passing into region 44. The larger particles are collected in the bin 22 (in the case of a single bin arrangement such as Fig 10) and in the outer region 26 of a 2 bin arrangement such as shown in Fig 1.

The shell 52' is shown cut-away to reveal the lower end of 38 in the same way as the hemispherical shell 52 in the earlier figures.

As shown in Fig 11, the lower part 122 of tubular member 58 may be separate from, so as not to rotate with, the upper end to which the turbine sections are attached, and may be supported in place by a circular plate 124 having an opening 126 therein (see the scrap plan view of Fig 11A).

Fig 13 shows how a radial and circular motion can be imparted to the airflow entering 96 by a hollow cap 128 attached to the upper end of the tube 58, so as to rotate therewith.

The wall of the cap is apertured by means of a plurality of windows, such as shown at 130. As the cap spins around its axis air leaves the windows with radial and rotational motion in the direction in which the cap spins.

A cylindrical shroud 132 which is stationary and extends from top to bottom of the chamber 114 includes a large number of openings such as 134 through which particles and air can pass. In order to pass to the suction source 10, the air has to reverse direction beyond the shroud and return via other of the openings 134, to allow it to pass via the central opening in the upper end of chamber 114 and through passage 136 to suction source 10. In so doing any heavier than air particles will tend to be left outside the shroud to be gathered up in the airflow returning to the second stage via passage 112.

The use of the rotating cap 128 obviates the need for the shell 118 of Figs 11 and 12.

In the case of the Fig 11, 12 and 13 embodiments, the passage 112 and the ports by which it communicates with 114 and 40 are typically 32mm diameter, the angle of the cone 120 (where employed) is 160° , the diameter of the holes 62 are in the range 2 - 2.5 mm, the gap between closed end 60 and the frusto-conical surface 64 is in the range 3mm to 18mm, and will depend on the diameter of the chamber 40, which typically lies in the range 65-80mm diameter. The gap referred to, and the necking of the tube 38 both resist back flow of the secondary vortex, and the diameter of the necked region is in the range 10mm to 18mm.

Although as shown in Fig 13 the holes 108 are shown as extending only over the lower part of the shroud 106, they may be (and preferably are) provided over most or all of the wall of the shroud as depicted in Fig 10, so that any air which is sucked in an axial and radial sense, due to the suction at 136, will not tend to pass back through holes which register with the windows 130 in 128, but will tend to migrate inwardly through holes nearer the upper end of the shroud.

It is to be understood that the two-bin collector of Fig 1 (with or without a valve or other device resisting mixing of particles in the inner bin with air in the descending or ascending vortex in 38) may be employed in conjunction with any of the second and/or third stage arrangements shown in Figs 2 to 13.

It is also to be understood that a particle level detector and switch such as shown in Fig 2 may be employed in any of the arrangements shown in any of the Figs (including Fig 1) for the purpose of at least alerting the user to the fact that the bin (or one of two bins) is full and needs to be emptied – if not also interrupting the power to the suction source.

It is also to be understood that the single bin and valve arrangement of Fig 2 may be employed with any of the second and/or third stage separators shown in any of the figures in the drawings.

The arrangements shown in the figures hitherto all relate to an upright vacuum powered air/particle separator, such as an upright vacuum cleaner. To reduce the overall height of such a device one or more of the 2nd and 3rd stages may be angled relative to the first stage such as shown in Figs 14 to 17. In all other regards they operate in just the same way as if the stages were mounted vertically one above the other. The opportunity has been taken to illustrate further variations on the make up of the second and third stages previously shown in earlier figures.

Fig 14 corresponds to the Fig 2 arrangement, as modified by Fig 2A, in which the end of the vortex tube 58 is bent around so as to enter the open end of the frusto-conical region 38.

Fig 15 corresponds to Fig 11 in so far as air and particles remaining near the wall of the third chamber will tend to return via a path 112 due to the depression at the other end of path 112 caused by the rotating mass of air in the second stage. However Fig 15 shows that the turbine of Fig 11 may be omitted. Fig 16 corresponds to Fig 12 in that a helix is

provided in the second stage (albeit stationary) and no turbine is provided in the second stage.

In Figs 14 to 16 the perforated shell 52" is shown of cylindrical configuration as distinct from the hemispherical and frusto-conical configurations in earlier figures.

Figs 17 and 17A correspond to Figs 13 and 13A.

In Figure 18 a vacuum source (such as a fan) 410 draws air from the upper end of the third stage of a three stage particle separator apparatus, to which dust/particle laden air is input at 412, to the first stage.

In the first stage the inlet 412 causes the incoming air to enter a cylindrical chamber 414 tangentially and to swirl therearound, so that larger particles entrained therein will tend to migrate to the wall of the chamber and air substantially free of larger particles will tend to migrate to the centre of the chamber and pass through apertures 416 in a curved shroud 218 which encloses a central annular space at the lower end of a frusto-conical housing 420 between it and an opening in the otherwise closed upper end 422 of the chamber 414.

A second similarly but oppositely curved baffle 424 extends from the junction of the curved shroud with the frusto-conical housing wall. Larger particles which under centrifugal force have been spun out to the wall of the chamber 414 and then fallen into the collection bin 426 (which forms the lower part of the chamber 414) are generally prevented from being sucked up in an upward direction, even when the bin 426 is full, by the pressure of the baffle 424. A handle 428 allows the bin to be detached from the chamber 414 for emptying.

Air which migrates through the holes 416 may still contain particles, which have to be removed, and this air is sucked into the annular region 430 surrounding the frusto-conical housing 420, and bonded by a cylindrical wall 432, exits via port 434. A conduit (not shown) conveys air exiting from 434 to an inlet 436 at the upper end of the frusto-conical

housing 420. Inlet 436 communicates tangentially with the interior of the upper end of the housing 420, so that air entering 420 is caused to describe a circular path therearound.

A vortex initiator in the form of an axially downwardly protruding collar 438, assists in converting the rotating airflow into a downwardly spiralling vortex which as it reaches the lower end of the housing 420, inverts in manner known per se, and begins to spiral in a central column, up the centre of the housing 420 towards the collar 438.

The sudden change of direction at the lower end of the housing 420 causes particles to be spun out of the vortex so as to fall through the open end of 420 into an intermediate collection chamber 440 entry to which is gained via a helix 442, the central upper end of which is spaced a given distance below the end of the frusto-conical internal surface of the housing 420. This distance will alter the position of the vortex inversion, and therefore the overall function of the vortex separation stage within 420, which forms the second separation stage in the apparatus.

Particles which enter the intermediate chamber 440 remain trapped therein until the vacuum source is removed or turned off, whereupon the ball valve formed by ball 444 and opening 446 at the lower end of chamber 440 opens, as the ball 444 falls down to the position shown in Figure 18, at the bottom of the cage 448 which extends below the chamber 440 to retain the all in close proximity to the opening 446 so that when vacuum is once again applied by 410, the initial air flow through the cage 448 and opening 440 will lift the ball and shut off that airflow, thereby sealing the lower end of chamber 440 from the bin 426.

Any particles collected in 440 while the ball 444 closes opening 446, will of course fall into the bin when the vacuum is removed at the end of a cleaning cycle.

The presence of the helix 442 ensures that if any particles are sucked into the chamber 40 (when the vacuum is first applied) from the bin 426, there is little chance of them rising into the vortex chamber 420 before the ball 444 closes the opening 446 and cuts off the

flow of air. Any particles which might have gained entry to chamber 440 remain therein, until the end of the cleaning cycle, when they will fall back into 426 together with any that have been collected in 440 from the vortex separation stage acting during the cleaning cycle.

The secondary vortex is enabled to leave the housing 420 by providing an opening 450 through the collar 438 into the upper chamber 452 absorbed by the cylindrical wall 454. The upper end of 452 is closed at 456 and a hollow tube 458 passes through an opening in 456 to extend axially of 454 and terminates in a hollow cylindrical canister 460 the wall of which is apertured by a plurality of small openings 462, and the lower end of which is a vertical cone 464 just above the opening 450. The conical end 464 deflects incoming air in a circularly radial manner, in all directions, and prevents the incoming air from directly reaching the apertures 462 in the wall of the canister 460.

Any particles and the associated airflow will tend to migrate into the lower end of a helical baffle 466 and progress upwardly to the second exit 468 (which leaves the upper end of the cylindrical housing 460 tangentially) whilst air that is free of particles can change direction through 180° and migrate radially inwardly before reaching the helix, and pass through the apertures 462 into the hollow canister 460 and from there up and through the hollow tube 458 to the source of vacuum 410.

Particle laden air exiting at 468 is returned via a pipe (not shown) to inlet 470 also at the upper end of the vortex chamber 420, where it is entrained into the circulating airstream at the upper end of 420 and becomes part of the primary and secondary vortices in 424, so that particles therein are again subjected to separation forces and the primary vortex changes direction to become the secondary vortex.

The upper chamber 454, cone 464 and helix 466 forms the third (final) separation stage.

The function of chamber 454, cone 464 and helix 466 is to convey to the vacuum source virtually particle free air from the incoming airstream at 450, and recycle air which still contains particles via 468 and 470 to the earlier separation stage in 420.

Very high separation efficiencies have been observed using apparatus as shown in Figure 18.

Figure 19 merely shows the third stage chamber to a larger scale and shows how the entrance 450 to the upper chamber can be varied to advantage, from that shown in Figure 18, by chamfering the upper edge of the inside wall of 450 as shown at 472 in Figure 19.

Figure 19 has also been shown oppositely handed to Figure 18, but in all other respects functions as described with reference to Figure 18.

In Figure 20, particle laden air is sucked into inlet 474 once a vacuum is established by operating a motor-driven vacuum primary fan/turbine 476. The incoming airflow is generally tangential to the wall of the cylindrical housing 478 and is thereby caused to form a circulating air mass around the region 480, at the upper end of the housing. Centrally is located a cylindrical vortex inducer 482 which extends into a hemispherical shell 484 containing a large number of very small openings 486 through which air can pass.

Below the surface 484 is located a similarly but oppositely convex curved shroud 488, which extends almost to the internal wall of the housing 478. Centrally of 482 and 484 a frusto-conical tubular surface 485 extends in an axially downward manner to communicate with an opening 490 in the centre of the shroud 484. A lightweight ball 492 which will normally occupy the lower end of housing 494, will, under the effect of a rising airflow through the housing 494, rise to engage and close off the opening 490 as shown in dotted outline at 492'.

The rapid circulation of the air around 480 will tend to separate particles in the airstream from the air by virtue of centrifugal forces, so that the particles will migrate to the wall of the housing 478 and fall under gravity, past the shroud 88, into the particle collating region 496 of the housing 478. The latter is in two parts, the upper part 480 and the lower part 496, and the latter has a handle 498 to assist in carrying it when full to be emptied.

The vacuum-source 476 inducing an airflow through 474, does so via the openings 486, so that the incoming airflow will eventually change direction and pass through the openings 488 and pass via the hollow interior of the shell 484 and vortex actuator 480 into a manifold 500 which has an exit at 501 from where the now largely particle-free air is conveyed via a pipe (not shown) to an inlet 502 of a further separation stage contained within a cylindrical housing 504 mounted coaxially above the housing 478 and manifold 500. The housing 504 includes a first downwardly extending frusto-conical axial extension 503 which leads to a second frusto-conical member 506. The interior of 504 communicates with the particle collecting bin 496 when the ball valve 490, 492 is open, and the frusto-conical member 506 provides the frusto-conical surface 485 previously referred to.

Centrally of the housing 504 is a downwardly extending tube 508 the lower end of which is capped at 510, the cylindrical wall of the cap being apertured at 512.

Above the cap 510 is a two-turn helical baffle 514 and at the upper end of 504, circumferentially remote from 502 in a second inlet 516 to which particle-containing air from the third stage is returned.

Although a helical baffle 442 has been shown as required above the ball valve in Figure 18, it has been found that provided there is a sufficient distance between the underside of 510 and the opening 490 in Figure 20, no helical baffle is required in the Figure 20 arrangement.

The tube 508 serves as the air outlet from 104 and the airstream passing up through 508 is circularly deflected in all directions by a downwardly facing conical end closure 518 of a further downwardly axial, extending tubular member 520 in a cylindrical housing 522. The closure is apertured as at 524 to provide an outlet from the interior of 522.

Particle-containing air from 508 tends to give up the particles as the radially deflected air abruptly changes direction and returns in a radial sense towards the openings in the cap 518. However, air which reaches the wall of 522 will tend to be deflected differentially to enter this lower end of a three turn helix 526. After traversing the helix the now circulating airstream leaves the housing 522 via exit 528 to be returned via a pipe (not shown) to inlet 516 to 504, for further processing.

In general air which reaches the wall of 522 will tend to be heavier due to the presence of particles and thus the air which migrates up the helix will tend still to be particle laden, and the reprocessing of this air is to remove the remaining particles.

Substantially particle free air exits via openings 524 and tube 520 to the vacuum source.

Advantageously it is found that the separation is so effective that there is no need for any filter in the path to the vacuum source.

As shown in Figure 21, the ball is freely contained within a cylindrical housing 494 the upper end 530 of which is sealingly secured to the lower open end of the shroud 484 of Figure 20. Radial protrusions 532, 534 prevent the ball from falling through the lower open end of the housing 494 – and as shown in Figure 23, four such radial protrusions are provided, 532, 534, 536 and 538. Near the open upper end of the housing 494 is an annular protrusion 540 which forms a valve seat which compensates with the ball 492 to close off the passage of air through the opening 542 defined by the annular protrusions 540, when the ball is lifted (as by airflow in an upward sense) when vacuum is first applied to the system.

Particles which collect above the ball 492 (when in the upper position) can fall past the ball (the diameter of which is somewhat less than that of the interior of the housing 494) and the spaces such as 544, 546, 548 and 550 allow the particles to pass out of the housing into the bin 496.

In Figure 23, the different parts of the separator shown in Figure 20 are shown rearranged. The same reference numerals have been employed to denote similar items which are common to the two Figures.

In general, the only difference is that instead of progressing in a downward sense, the airflow 504 and 522 will move in a generally upward manner and particles reaching the top of the helix 514 have to enter the passage 552 and migrate therealong before they can reach the collection region 506. The high velocity of the particles in the rotating airstream around the apertured cap 510 ensures that although there is no airflow along passage 552, the particles will nevertheless traverse the passage.

The advantage of the layout of the parts in Figure 23 is the lower profile obtained. As shown in Figure 23, the unit could be accommodated more readily in a so-called "cylinder" vacuum cleaner, whereas the layout of Figure 20 is more appropriate for a so-called upright vacuum cleaner.

The apparatus described herein may also be used for separating liquids (eg water) from gases (eg air) since in general liquids are more dense than gases. If solid particles are also present of material having a density greater than the gaseous phase (and more probably also the liquid phase), these can also be separated in the same manner from the gaseous phase along with the liquid phase, and in a second pass through the apparatus or during the passage through a second similar apparatus, the solids can be separated from the liquid phase, provided the relative densities are sufficiently different.

In any situation where liquid is involved, a liquid trap or filter must be provided if the vacuum fan is driven by an electric motor, or steps taken to separate any liquid from the motor, or a non-electric vacuum pump should be used.

As shown in Figure 24 the collecting bin 700 containing the first separation stage and ball-valve 702 is angled at approximately 45° to the axis of the second and third separation stages 704, 706. The electric motor driven fan for providing the air flow is not shown, but the air outlet which leads to it is denoted at 708.

Recirculation of particle laden air is achieved from outlet 710 to outlet 712 and particle laden air from the first stage separator is fed from manifold 714 via passage 716 to inlet 718.

Figure 25 shows how the three sections 700, 704 and 706 can be fitted within a conventional cylinder vacuum cleaner housing 720, in which the fan and motor (generally designated 722) are mounted in the foot of the lower forward part of the overall housing between the two longer wheels (one is shown at 724). The removable dust-bin 726 is located in the lower rear end of the housing between the two smaller wheels (one is shown at 728). The housing includes a carrying handle 730 and a vacuum hose 732 is fitted to a connection 734 at the front end of the housing from where it communicates with an inlet (not shown in Figure 25) to the first stage 700 (denoted by 736 in Figure 24).

The curved shroud 488 and apertured part hemispherical surface 484 and cylindrical region 482 of Figure 20 may be replaced by the arrangement shown in Figure 26. Here the incoming particle-laden airflow from 474 initially is caused to circulate around a cylindrical shell 740, an upper section 742 of which is solid walled and shown partly cut away and the remainder of which is perforated as at 744 with circular openings in the range 1-2mm diameter (typically 1.7mm diameter). Below the cylindrical shell 740 is a flared shell 746 which can if desired house a dump valve as previously described. It is believed this alternative arrangement for exiting air into an annular outlet passage 748

(shown dotted) around the frusto-conical tube 485 may assist in separating fibrous particles from the incoming airstream.

Where shown, the helixes have an angle of between 2° and 10° typically of the order of 4° , and the apertures such as 86, 112, 124 and 344 (as mentioned above) are circular and have a diameter in the range 1-2mm – typically 1.7mm.

C809.00/H

CLAIMS

1. A method of separating particles from an airstream which is established by suction and which has already undergone at least one earlier particle separation step, involves:
 - (1) introducing the airstream in a generally axial sense into a generally cylindrical chamber having two exits for air to leave the chamber, a first which preferentially exits particle-free air in a direction towards the suction source, and a second for returning particles to an earlier separation stage;
 - (2) radially deflecting the incoming air on entry;
 - (3) constraining the air to follow a helical path before it can leave via the second exit, and
 - (4) forcing the air to change its general direction of movement in the chamber before it can leave via the first exit.

2. A method as claimed in claim 1 wherein the axis of the chamber is generally vertical and the movement of the air in the chamber is in a generally upward sense, whereby particles entrained in the airflow will tend to be elevated into and follow the helical path and leave via the second exit for recirculation to the earlier separation stage.

3. A multi-stage air/particle in which the final stage comprises:
 - (1) a generally cylindrical chamber provided with a central aperture at one end through which particle laden air from an earlier separation stage is introduced into the chamber;
 - (2) an air deflector adapted to radially deflect incoming air in a radially outward sense towards the internal wall of the chamber;

- (3) a first exit for air from the chamber, located centrally of the chamber so that radially deflected air has to change its direction of flow within the chamber to exit via the first exit;
- (4) a second exit, located remote from the first, and separated therefrom by a baffle which defines a helical path through the chamber leading to the second exit;
- (5) a first passage for connecting the first exit to a suction source, and a second passage for returning particles to an earlier separation stage of the apparatus.

4. Apparatus as claimed in claim 3, wherein the second exit is connected to an input to the separation stage immediately preceding the final stage.

5. Apparatus as claimed in claim 3 or 4, wherein the first exit is provided in the wall of a tube which extends centrally of the chamber from the upper end thereof, towards the central aperture air inlet, and which has a closed lower end which is spaced from the inlet aperture.

6. Apparatus as claimed in claim 5, wherein the first exit comprises a plurality of small apertures in the tube wall which communicate with the interior of the tube.

7. Apparatus as claimed in any of claims 3 to 6 wherein the air deflector has a conical surface, the apex of which points towards the air inlet aperture in the said one end of the chamber.

8. Apparatus as claimed in any of claims 5 to 7 wherein the conical surface is formed at or carried by the lower end of the central tube.

9. Apparatus as claimed in any of claims 3 to 8, wherein the baffle comprises an annular helix situated between the central tube and the cylindrical inside of the chamber.

10. Apparatus as claimed in any of claims 3 to 9, wherein the second exit comprises an opening in the wall of the chamber leading to a passage which extends generally

tangentially of the chamber, and the position of the opening and the direction of the passage is such that particles leaving the helix can enter and travel therealong without change of direction.

11. Apparatus as claimed in any of claims 3 to 10, wherein the preceding separation stage comprises a vortex separator comprising a frusto-conical chamber into the large diameter end of which particle-laden air enters tangentially to form a primary vortex which as it rotates as it simultaneously travels axially of the frusto-conical chamber towards the smaller diameter end thereof, at which a secondary vortex is established which returns axially and centrally of the frusto-conical housing towards the larger diameter end thereof, which end includes a central opening through which the rising secondary vortex can pass unimpeded axially into the chamber containing the final separation stage, the change of direction from primary to secondary vortex producing a precipitation of particles from the airstream, to produce separation in the preceding stage.

12. Apparatus as claimed in claim 11. wherein the central opening in the larger diameter end of the frusto-conical housing communicates directly with the central opening in the chamber of the final separation stage.

13. Apparatus as claimed in claim 11, wherein one end of the cylindrical chamber of the final separation stage comprises the larger diameter end of the frusto-conical housing of the preceding separation stage.

14. Apparatus as claimed in any of claims 11 to 13, wherein the vortex separator forming the earlier separation stage is itself supplied with particle-laden air from a preliminary separator into which an air-particle mixture is drawn by the suction effect, and in which heavier than air particles in the incoming airstream are removed centrifugally before transfer to the inlet to the vortex separator.

15. Apparatus as claimed in any of claims 11 to 14, wherein the central opening in the larger diameter end of the frusto-conical housing of the preceding separation stage is

surrounded by a cylindrical collar which protrudes axially of the housing and forms a vortex initiator for the airstream tangentially entering the second stage housing.

16. Apparatus as claimed in claim 15, wherein the external surface of the collar is itself frusto-conical.

17. Apparatus as claimed in claim 11, wherein the said preceding stage comprises a generally cylindrical chamber, similar to that of the final stage, but in which the airflow is in the opposite sense to that in the final stage, and wherein the inlet to the chamber for particle-laden air is at the one end thereof, and introduces the air in a tangential manner so as to produce a circulating airflow at that end of the chamber, and a central tube extends axially from that end of the chamber towards the opposite end, at which end it is formed with at least one opening which serves as an exit for air to leave the chamber to transfer to the final separation stage, and the airflow in the chamber of the said earlier stage is forced to follow a helical path axially of the chamber due to the presence of an annular helical baffle located between the exterior of the central tube and the inside of the chamber wall between the inlet and exit ends of the chamber, and an axial extension to the chamber is provided which communicates with the interior thereof in the region of the end of the central tube, which extension serves to collect particles precipitated from the airstream as the latter changes direction to leave via the central tube.

18. Apparatus as claimed in claim 17, wherein the helical baffle has less than one complete turn, or has between one and three turns, preferably two turns.

19. Apparatus as claimed in claim 18, wherein a second inlet is provided at the same end of the previous stage chamber as the first mentioned inlet, to allow particle-bearing air from the final stage to be recirculated to the preceding stage chamber.

20. Apparatus as claimed in claim 19, wherein the second inlet also introduces air into the earlier stage chamber in a tangential manner.

21. Apparatus as claimed in claim 20, wherein the first and second tangential inlets both establish circulation of air in the chamber in the same sense.

22. Apparatus as claimed in claim 21, wherein the second inlet is circumferentially remote from the first inlet.

23. Apparatus as claimed in claim 22, wherein the first and second inlets are 180° apart.

24. Apparatus as claimed in any of claims 17 to 23, wherein the final stage chamber is mounted vertically above a chamber containing the said preceding separation stage, and the latter is located vertically above a preliminary centrifugal separator.

25. Apparatus as claimed in claim 24, insofar as it depends from claim 17, wherein the axial extension to the said earlier stage chamber, extends axially into the preliminary centrifugal separator.

26. Apparatus as claimed in any of claims 17 to 23, wherein the final and preceding separation stages are situated to the side of the preliminary centrifugal separator, with the final stage located below the said preceding stage, and a passage extends from the upper end of the said preceding stage chamber to convey particles separated from the airflow in the preceding stage chamber, to a particle collection region.

27. Apparatus as claimed in claim 26, wherein the passage leaves the upper end of the preceding stage chamber in a tangential manner, or in a radial manner.

28. Apparatus as claimed in any of claims 17 to 27, wherein the preliminary centrifugal separator is located at the upper end of a particle collecting bin, and a valve is provided, which is closed whilst suction induced airflow exists through the apparatus, but which when opened, allows particles gathered above the valve to fall into the bin, to join other particles which have entered the bin due to centrifugal separation.

29. Apparatus as claimed in claim 28, wherein particle level sensing means is provided together with a switch, whereby when the particle content of the bin reaches a given level therein, the power to the suction producing device is shut off, to stop continued operation of the apparatus until the bin is emptied, and/or an alarm signal is generated

30. Apparatus as claimed in claim 29, wherein the switch is a microswitch activated through a membrane type of diaphragm and located in a small housing below a cage containing a valve closure member.

31. Apparatus as claimed in claim 29, wherein the switch is a microswitch located to the side of the ball housing with an extension of the microswitch actuator extending down below the ball housing, to form a lightweight paddle which is lifted as the particle content rises, until the switch is actuated.

32. Apparatus as claimed in any of claims 28 to 31, wherein an annular gap between an opening in the upper end of the bin and the outside of the lower end of a frusto-conical housing vortex separation stage (constituting the said preceding stage) serves as the air outlet from the primary centrifugal separation stage and the annular gap is blinded by a shell which extends from the opening in a downward sense to merge with the wall of the frusto-conical housing.

33. Apparatus as claimed in claim 32, wherein the shell is generally cylindrical and solid walled in an upper section thereof, to form a vortex starter at the upper end of the bin, which itself is also cylindrical, and the shell is apertured below the vortex starter section to allow air to pass into the shell and up the internal annular gap to pass to the next particle separation stage of the apparatus.

34. Apparatus as claimed in claim 33, wherein a radially extending annular ridge is provided between the upper solid walled vortex starter section of the shell and the lower apertured region, so that the rotating mass of air is forced radially outwardly before it registers with the lower apertured region, to assist in centrifugally separating particles

from the air before the latter is drawn inwardly under suction to exit through the openings in the shell.

35. Apparatus as claimed in any of claims 3 to 34, wherein an apertured cylindrical sleeve surrounds the helical baffle in the final stage.

36. Apparatus as claimed in claim 33, wherein an annular region exists around the apertured sleeve between it and the cylindrical wall of the final stage chamber, into which heavier than air particles will tend to pass through the apertures in the sleeve for return to an earlier separation stage.

37. Methods and apparatus for separating particles from air substantially as herein described or with reference to the accompanying drawings.

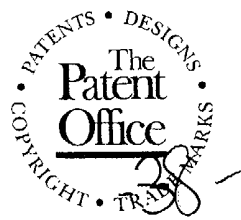

INVESTOR IN PEOPLE

Application No: GB 0116411.0
Claims searched: 1-37

Examiner: Jason Scott
Date of search: 30 January 2002

Patents Act 1977 Search Report under Section 17

Databases searched:

UK Patent Office collections, including GB, EP, WO & US patent specifications, in:

UK Cl (Ed. T): B2P

Int Cl (Ed.7): B04C

Other: ONLINE: WPI, JAPIO, EPODOC

Documents considered to be relevant:

| Category | Identity of document and relevant passage | Relevant to claims |
|----------|-----------------------------------------------------------------------------------------------------|--------------------|
| A | GB 2169822 A WESTINGHOUSE ELECTRIC CORP. See whole document | |
| X | GB 2020205 A KRAFTWERK See whole document and in particular page 1, line 118 to page 2, line 22. | 1 & 2 |

| | | | |
|---|-----------------------------------------------------------------------------------------------------------|---|------------------------------------------------------------------------------------------------------------------|
| X | Document indicating lack of novelty or inventive step | A | Document indicating technological background and/or state of the art. |
| Y | Document indicating lack of inventive step if combined with one or more other documents of same category. | P | Document published on or after the declared priority date but before the filing date of this invention. |
| & | Member of the same patent family | E | Patent document published on or after, but with priority date earlier than, the filing date of this application. |