

(12) PATENT
(19) AUSTRALIAN PATENT OFFICE

(11) Application No. AU 200038282 B2
(10) Patent No. 763089

(54) Title
Lockable container

(51)⁷ International Patent Classification(s)
E05B 073/00

(21) Application No: **200038282**

(22) Application Date: **2000.04.10**

(87) WIPO No: **WO00/61899**

(30) Priority Data

(31) Number	(32) Date	(33) Country
9908080	1999.04.09	GB

(43) Publication Date : **2000.11.14**

(43) Publication Journal Date : **2001.01.11**

(44) Accepted Journal Date : **2003.07.10**

(71) Applicant(s)
Robert Malcolm Broadhead

(72) Inventor(s)
Robert Malcolm Broadhead; David Frank Whitehead

(74) Agent/Attorney
CULLEN and CO,GPO Box 1074,BRISBANE QLD 4001

(56) Related Art
EP 616103
WO 95/14841
EP 640737



INTERNATIONAL APPLICATION PUBLISHED UNDER THE PATENT COOPERATION TREATY (PCT)

(51) International Patent Classification⁷:
E05B 73/00

A1

(11) International Publication Number: WO 00/61899

(43) International Publication Date: 19 October 2000 (19.10.00)

(21) International Application Number: PCT/GB00/01302

(22) International Filing Date: 10 April 2000 (10.04.00)

(30) Priority Data:
9908080.6 9 April 1999 (09.04.99) GB

(71)(72) Applicant and Inventor: BROADHEAD, Robert, Malcolm [GB/US]; 14921 North Applegate Road, Grants Pass, OR 97527 (US).

(72) Inventor, and

(75) Inventor/Applicant (for US only): WHITEHEAD, David, Frank [GB/GB]; Whitehead Precision Engineering Ltd., Units 1 & 2, Spring Gardens Industrial Estate, Romford, Essex RM7 9LD (GB).

(74) Agents: GEMMELL, Peter, Alan et al.; Dummett Copp, 25 The Square, Martlesham Heath, Ipswich IP5 3SL (GB).

(81) Designated States: AE, AG, AL, AM, AT, AU, AZ, BA, BB, BG, BR, BY, CA, CH, CN, CR, CU, CZ, DE, DK, DM, DZ, EE, ES, FI, GB, GD, GE, GH, GM, HR, HU, ID, IL, IN, IS, JP, KE, KG, KP, KR, KZ, LC, LK, LR, LS, LT, LU, LV, MA, MD, MG, MK, MN, MW, MX, NO, NZ, PL, PT, RO, RU, SD, SE, SG, SI, SK, SL, TJ, TM, TR, TT, TZ, UA, UG, US, UZ, VN, YU, ZA, ZW, ARIPO patent (GH, GM, KE, LS, MW, SD, SL, SZ, TZ, UG, ZW), Eurasian patent (AM, AZ, BY, KG, KZ, MD, RU, TJ, TM), European patent (AT, BE, CH, CY, DE, DK, ES, FI, FR, GB, GR, IE, IT, LU, MC, NL, PT, SE), OAPI patent (BF, BJ, CF, CG, CI, CM, GA, GN, GW, ML, MR, NE, SN, TD, TG).

Published

With international search report.

(54) Title: LOCKABLE CONTAINER

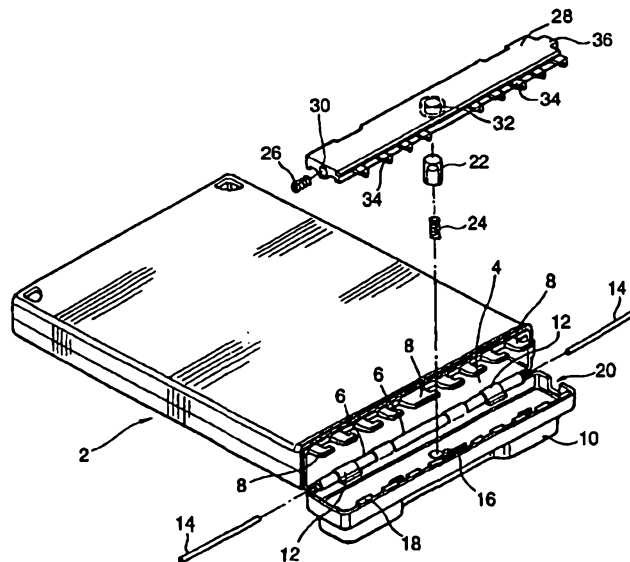

(57) Abstract

A lockable container for an article comprises a frame (2) which has an access opening (4), a closure member (10) which is pivotally mounted in relation to the frame (2), and a latch member (28) which is axially movable within the closure member (10) between a latched position and an unlatched position. The latch member (28) and the frame (2) are each provided with one or more interengageable detents (8, 34) whereby when the closure member (10) is in a closed position and the latch member (28) is in the latched position the detents (8, 34) are engaged and prevent pivoting of the closure member (10). Movement of the latch member (28) to the unlatched position causes the detents to disengage and permit pivoting of the closure member. The closure member (10) is provided with a locking member (22) for engaging the latch member (28) to retain it against axial movement.

- 1 -

LOCKABLE CONTAINER

FIELD OF THE INVENTION

5 The present invention relates to a lockable container, notably a lockable container for displaying pre-recorded storage media such as digital versatile discs (DVDs), video cassettes or compact discs (CDs).

10 BACKGROUND TO THE INVENTION

Pre-recorded storage media such as CDs and video cassettes are usually put up for sale in a plastic case or the like, which carries information about the disc
15 or tape as well as carrying sales promotional material or artwork to attract a purchaser. To prevent theft of the media from a shop various lockable display containers have been proposed which house the disc or tape in its case and prevent a thief gaining access to
20 the disc or tape without breaking the container or removing the container from the shop. The container can be fitted with alarm means so that it cannot be removed from the shop without actuating an alarm. One type of known container employs a spring loaded pin or
25 the like which locates in a recess in a wall of the case, for example as disclosed in EP 0 312 172. Such containers can only be used with cases of a specific size, which have a recess which registers with the pin. Other types of container employ a spring loaded pin to
30 retain a stop member over part of an access opening in the container, displacement of the pin by a magnet permitting the stop member to move out of the way of the access opening by translation or by translation and pivoting, for example as disclosed in EP 0 541 733 and
35 EP 0 666 954.

- 2 -

Most lockable display containers have an access opening which is at least partly open at all times, to permit insertion and removal of the disc or tape in its case. A problem with such containers is that the disc or tape is only protected from damage at the opening by its case, which therefore needs to be tough. For cost reasons, however, it is desirable to make cases from more frangible materials such as cardboard or vacuum-formed plastics materials. Many DVDs, for example, are sold in soft, vacuum-formed plastics cases.

It has been proposed, in WO95/14841, to provide an anti-theft box comprising a cassette with an elongate opening at one face. The cassette has a lid which can be locked to cover the open end of the cassette. To lock the lid on the cassette, a lock mechanism is provided which comprises a lock slide which has lock bolts for engaging in holes in the lid and in a long side wall of the cassette. The lock slide is moved transversely to the long axis of the opening to lock and unlock the lid. The lock slide is moved by an operating slide which slides transversely to the movement of the lock slide, or by an operating pin which is passed from the lower side of the lock slide through a transverse slot in the lock slide and attached to the lock slide.

The present invention seeks to provide an improved lockable container for DVDs and other valuable items.

30

SUMMARY OF THE INVENTION

According to an aspect of the present invention there is provided a lockable container for an article, comprising a frame which has an access opening whereby an article can be inserted into or removed from the

35

- 3 -

frame, and a closure member which is pivotally mounted in relation to the frame and pivotable between an open position in which an article can be inserted into or removed from the frame through the access opening and a
5 closed position in which the closure member blocks substantially all of the access opening, the closure member housing an elongate latch member which is axially movable within the closure member between a latched position and an unlatched position, the latch
10 member and the frame each being provided with one or more interengageable detents whereby when the closure member is in the closed position and the latch member is in the latched position the detents are engaged and prevent pivoting of the closure member, movement of the
15 latch member to the unlatched position causing the detents to disengage and permit pivoting of the closure member, the closure member being provided with a locking member adapted to move between a locked position at which the locking member engages the latch
20 member so as to retain it against axial movement, and an unlocked position at which the locking member permits axial movement of the latch member.

The latch member may be of unitary construction for
25 simplicity of manufacture. It may be moved to the latched position by pushing with a user's finger.

The frame could be a skeletal frame, but it is preferred that the frame has no openings other than the
30 access opening, so that when the closure member is in the closed position an article contained within the frame cannot be tampered with.

The container of the invention is of particular use for
35 storing and displaying DVDs and other media which are fragile or which have frangible or scratchable cases.

- 4 -

The frame preferably comprises two rectangular or square flat sides and four narrow sides, one of which provides the access opening.

5 The entire locking mechanism may be housed in the closure member, which may have external features to enable the container to be mounted in a display rack. This permits a plurality of containers to be stacked side by side without any part of the locking mechanism
10 projecting sideways or upwards. Alternatively, the closure member could be provided with hanging means, for example a hook, to permit the container to be hung up without projections from the bottom or sides of the container taking up space.

15

The locking member can be a spring biased jaw or clamp which acts to grip the latch member. However it is preferred that the locking member positively engages with the latch member, for example by engaging in a
20 slot or recess so that the latch member is positively secured in position once it reaches the latched position. A leaf spring or a spring-biased magnetic pin may be used. In a preferred embodiment, the locking member is a pin which is spring biased in a
25 bore or recess in a basal wall of the closure member. The exposed head of the pin may locate in a hole in the latch member in a similar manner to the engagement of the pin and sliding rail in EP 0 541 733. The pin may be withdrawn from the latch member by means of a
30 magnet, to permit the latch member to be slid to the unlatched position.

In a preferred embodiment, the latch member is biased to either the latched or the unlatched position by
35 spring means. To facilitate opening of the container, it is preferred that the latch member is biased to the

- 5 -

unlatched position, so that when the locking member is moved to the unlocked position the latch member moves to the unlatched position.

5 When in the latched position, the latch member preferably prevents pivoting of the closure member to the open position by engagement of at least one of the detents with at least one tab on the closure member. This permits the container to be assembled by simply
10 placing the latch member in the closure member. However, the invention is not limited to this embodiment, and other means could be used for preventing pivoting. For example, the closure member may be provided with a pocket or groove in which the
15 latch member is slidably received.

BRIEF DESCRIPTION OF THE DRAWINGS

The invention will now be further described, by way of
20 example, with reference to the following drawing in which:

Figure 1 is a perspective view of a lockable container for display of a DVD case in accordance
25 with one aspect of the present invention;

Figure 2 is a perspective view of the lockable container of Figure 1 in a locked state;

30 Figures 3 and 4 are perspective views of the frame of the lockable container of Figure 1;

Figures 5 and 6 are perspective views of the closure member of the lockable container of Figure
35 1;

- 6 -

Figures 7 and 8 are perspective views of the latch member of the container of Figure 1;

5 Figure 9 is an exploded view of the lockable container of Figure 1;

10 Figure 10 is a perspective view of the container of Figure 9 when assembled, with the closure member in an open position;

Figures 11 and 12 are enlarged partial X-ray views of details of the container of Figure 10; and

15 Figure 13 shows a known magnetic device for releasing the locking member in a container in accordance with the present invention.

DETAILED DESCRIPTION

20 The display container comprises a tough, transparent frame 2, for example of polycarbonate, a closure member 10 and a latch member 28.

The frame 2 is in this example a generally
25 parallelepipedic box having an elongate access opening 4 along one face. For manufacturing convenience, the frame 2 has two small wedge-shaped apertures at the bottom corners of one face. These apertures are not important or necessary for the functioning of the
30 container, and could be eliminated so that the frame 2 has only a single opening. The frame 2 is dimensioned so that a case 3 for a DVD, shown in broken lines in Figure 1, is a sliding fit within the container.

35 To lock the DVD case 3 in the container, the case 3 is fully inserted into the frame 2 in the direction of the

- 7 -

arrow A. The frame is then pivoted about a hinge in the direction of the arrow B so that its access opening 4 is covered by the closure member 10. Finally, the elongate latch member 28 is pushed axially in the direction of arrow C to lock the closure member 10 to the frame 2 as will be explained below.

The frame 2 has hinge members 6 along one long edge of the access opening 4, and a plurality of generally L-shaped detent members 8 formed along the opposed edge, as best shown in Figure 4. The closure member 10 has hinge members 12 along one long edge, as best shown in Figure 6. The respective hinge members 6, 12 butt together side by side to form a pair of hinge housings having blind tubular bores into each of which is inserted a hinge pin 14. The hinge pin 14 is a close fit for the insides of the hinge members 6, 12 and, once inserted, cannot be removed without breaking the container.

The latch member 28 is slidably housed in the closure member 10, retained by tabs 18 on the closure member 10. At one end of the latch member 28 is a blind bore 30 for receiving a spring 26. When the latch member 28 is housed in the closure member 10, the spring 26 biases the latch member to the right as shown in Figure 10.

The closure member 10 has a blind bore 16 and the latch member 28 has a blind bore 32. A magnetically movable pin 22 sits in the bore 16 on the closure member, biased towards the latch member 28 by a spring 24. If the latch member is pushed to the left as shown in Figure 10, for example by the action of a user's finger on a nub 36 which projects through an aperture 20 in the closure member, the bores 16, 32 move into register

- 8 -

and the pin 22 is urged transversely to locate in the bore 32 in the latch member thereby preventing axial movement of the latch member.

5 To protect an article in the frame 2, the closure member 10 is pivoted about the hinge members 6, 12, with the latch member 28 in the unlatched position so that the closure member 10 completely blocks the access opening 4. In this closed position, the tabs 18 on the
10 closure member and the detents 34 on the latch member are disposed in spaces adjacent to the detents 8 on the frame 2. The user pushes the nub 36 until the pin 22 engages in the latch member 28 as described above, thereby locking the latch member and preventing sliding
15 movement of the latch member. In this position, the detents 34 on the latch member 28 engage with the detents 8 on the frame 2, thereby preventing pivoting of the closure member 10 away from the closed position.

20 To open the container, a known magnetic release device 38 (Figure 13) is used by the sales person. The magnetic release device 38 comprises a base plate 40 having screw holes 42 by which it is secured to a work surface (not shown). The base plate 40 carries a
25 circular magnet 44 having a transverse diametric groove 46 cut in it. When the closure member 10 is inserted into the groove 46 the magnet 44 pulls the locking pin 22 to cause the pin 22 to withdraw fully from the bore 32 in the latch member 28. The spring 26 pushes the
30 latch member 28 to the unlatched position, allowing the container to be opened by pivoting of the closure member to the open position.

The external face of the closure member 10 may be
35 shaped to enable the container to stand up in a rack, or to be hung on a hook.

The invention provides a lockable container for protecting and displaying an article at point of sale, for example a DVD or a video cassette, optionally with
5 packaging material to brace the product inside the container.

All the components of the container, except for the pin
22 and springs 24, 26 can be fabricated from injection
10 moulded plastics materials which may be transparent or translucent. It is also envisaged that, as known per se, the interior of the container would be provided with a magnetic strip or the like which activates an
alarm system if the container is removed without proper
15 authorisation.

- 10 -

CLAIMS

1. A lockable container for an article, comprising a frame (2) which has an access opening (4) whereby an article can be inserted into or removed from the frame (2), and a closure member (10) which is pivotally mounted in relation to the frame (2) and pivotable between an open position in which an article can be inserted into or removed from the frame (2) through the access opening (4) and a closed position in which the closure member (10) blocks substantially all of the access opening (4), the closure member (10) housing a latch member (28) which is axially movable within the closure member (10) between a latched position and an unlatched position, the closure member (10) being provided with a locking member (22) adapted to move between a locked position at which the locking member (22) engages the latch member (28) in the latched position so as to retain it against axial movement, and an unlocked position at which the locking member (22) permits axial movement of the latch member (28), wherein:

the frame (2) is provided with a detent (8) and the closure member is provided with a tab (18) disposed adjacent to the detent (8) when the closure member (10) is in the closed position, and

the latch member (28) is provided with a detent (34) disposed between and engaging with the detent (8) of the frame (2) and the tab (18) when the latch member (28) is in the latched position so as to prevent pivoting of the closure member (10) to the open position, the detent (34) on the latch member (28) disengaging from the detent (8) on the frame (2) when the latch member (28) is moved to the unlatched position, thereby permitting the closure member to be pivoted to the open position.

35

- 11 -

2. A lockable container as claimed in claim 1, wherein the frame (2) is provided with a plurality of detents (8), and the closure member (10) is provided with a plurality of tabs (18) which are disposed adjacent to the said
5 detents (8) when the closure member (10) is in the closed position, and wherein the latch member (28) is provided with a plurality of detents (34) which are disposed between and engage with the detents (8) of the frame (2) and the tabs (18) when the latch member (28) is in the
10 latched position so as to prevent pivoting of the closure member (10) to the open position, the detents (34) on the latch member (28) disengaging from the detents (8) on the frame (2) when the latch member (28) is moved to the unlatched position, thereby permitting the closure member
15 to be pivoted to the open position.

3. A lockable container as claimed in claim 1 or claim 2, wherein the locking member is a pin (22) biased by spring means (24) and movable in response to a magnetic
20 field of suitable magnitude.

4. A lockable container as claimed in any one of the preceding claims, wherein the latch member (28) is urged to the unlatched position by spring means (26).
25

5. A lockable container as claimed in any one of the preceding claims, wherein the latch member (28) is provided with a region (36) which is accessible to a user's finger whereby pushing on that region causes the
30 latch member to move axially to the latched position.

6. A lockable container as claimed in any one of the preceding claims, wherein the blocking member (10) is pivotally connected to the frame (2) by a hinge comprising
35 at least one hinge housing (6, 12) and at least one hinge

- 12 -

pin (14) journalled in a blind bore in the housing, no part of the hinge pin projecting beyond the entrance to the housing.

5 7. A lockable container as claimed in claim 1, wherein the access opening (4) is the only opening to the inside of the frame (2).

10 8. A lockable container as claimed in any one of the preceding claims, wherein the latch member (28) is of unitary construction.

15 9. A lockable container as claimed in any one of the preceding claims, wherein the said detents (8, 34) are L-shaped or hook shaped.

20 10. A lockable container as claimed in any one of the preceding claims, wherein the closure member has external features which enable the container to be mounted in a display rack.

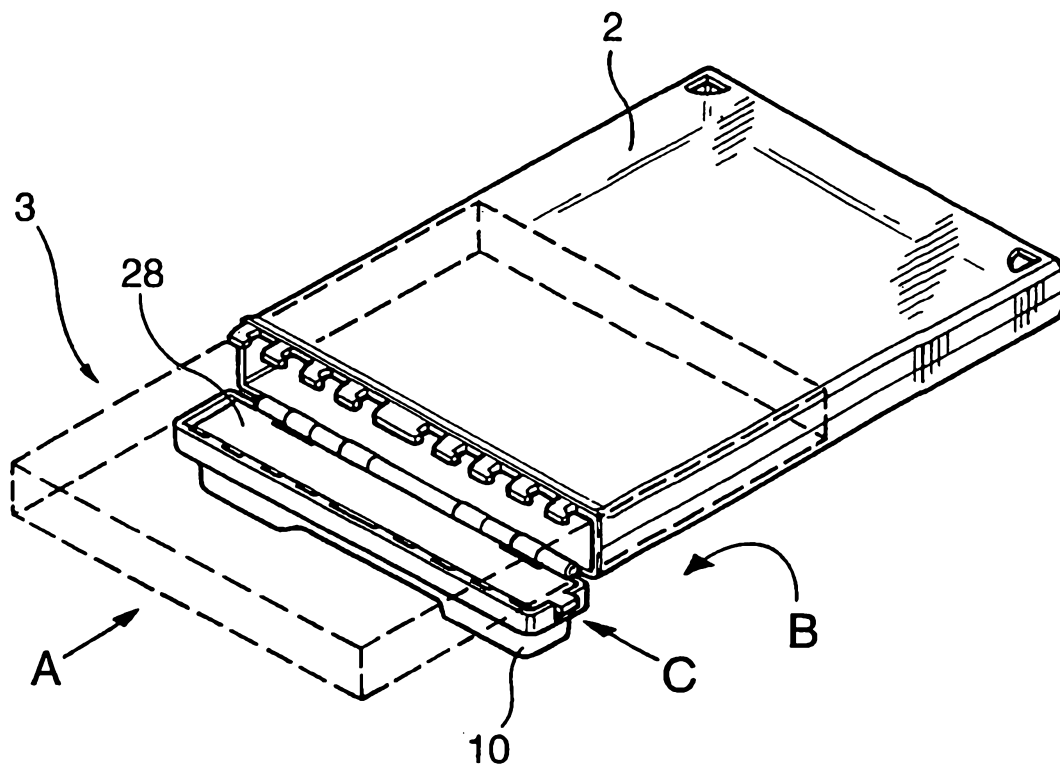

Fig.1

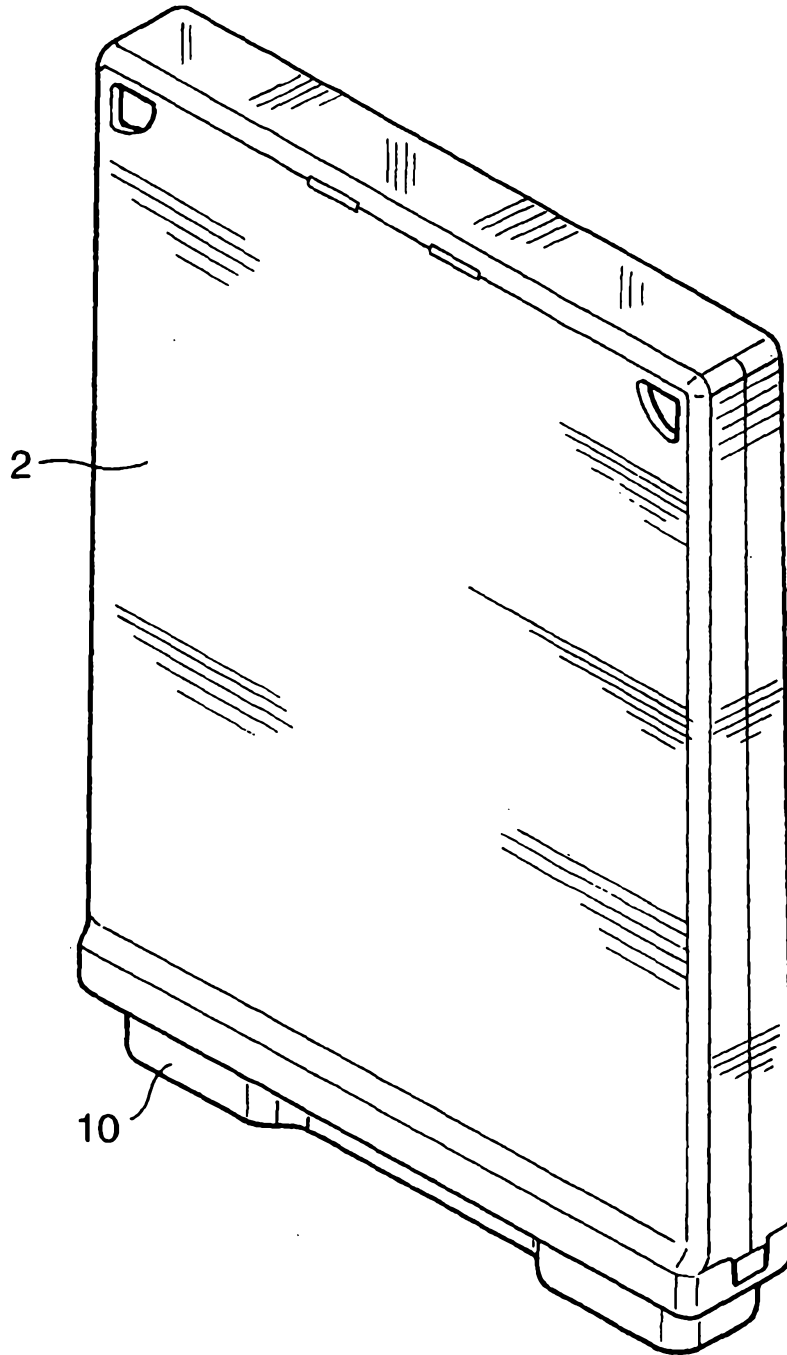

Fig.2

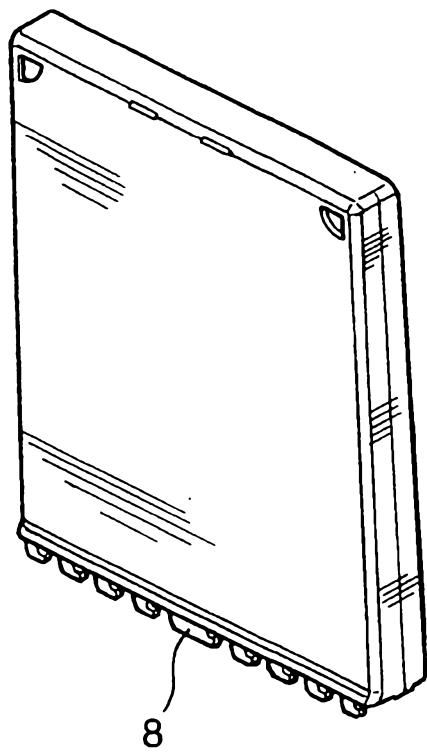

Fig.3

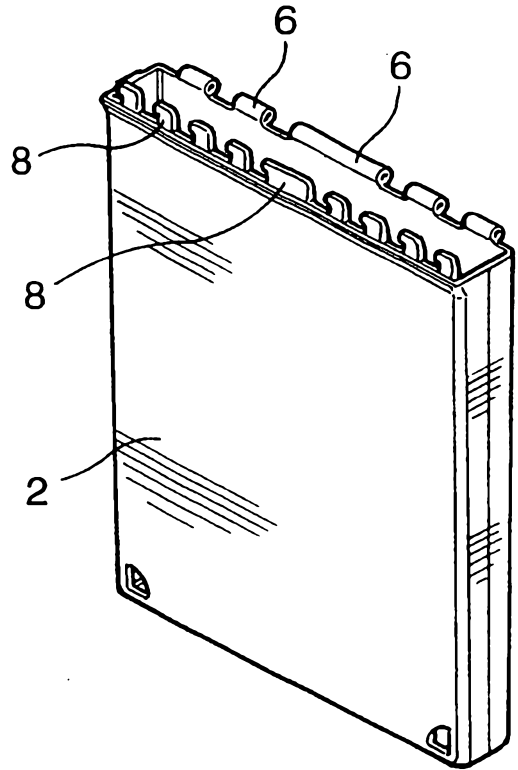

Fig.4

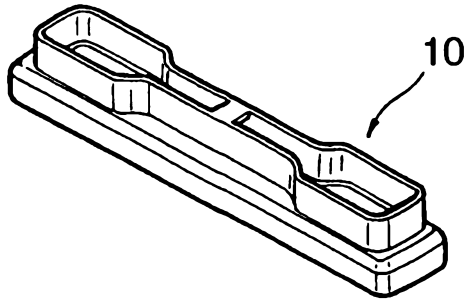

Fig.5

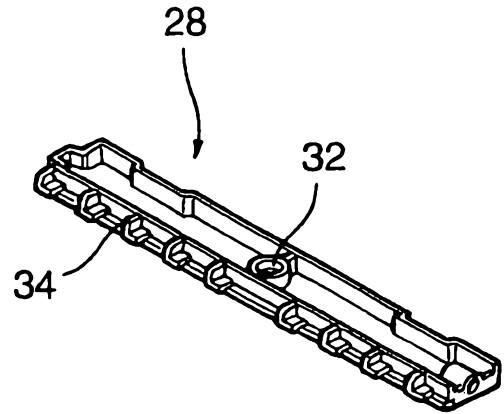

Fig.7

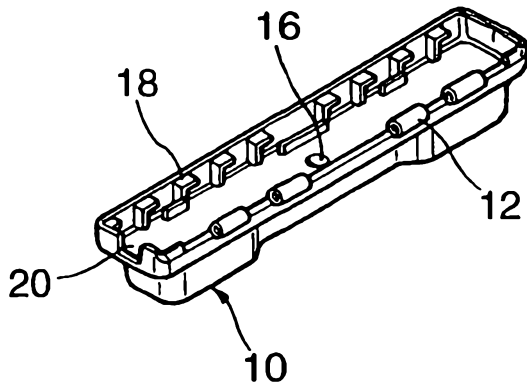

Fig.6

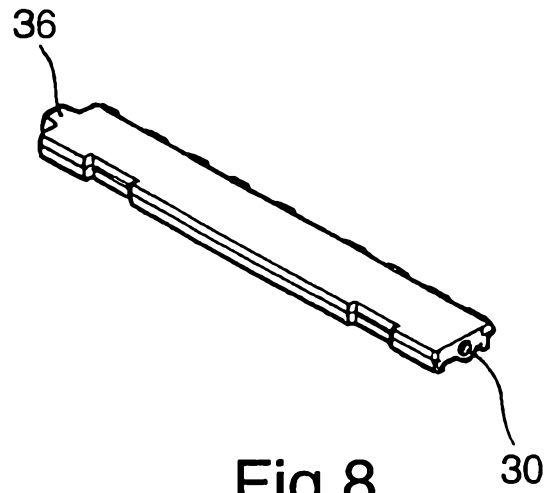

Fig.8

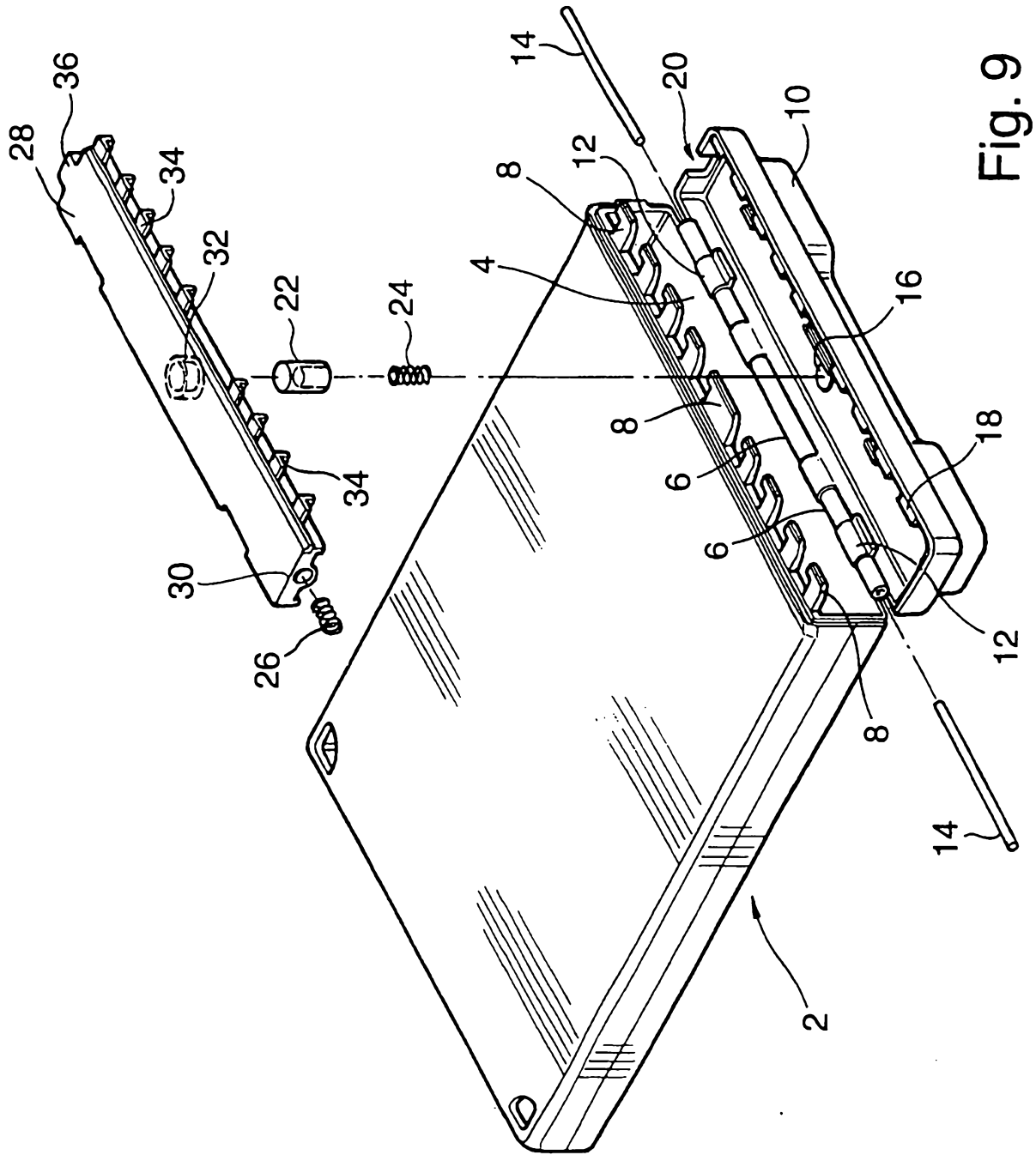

Fig. 9

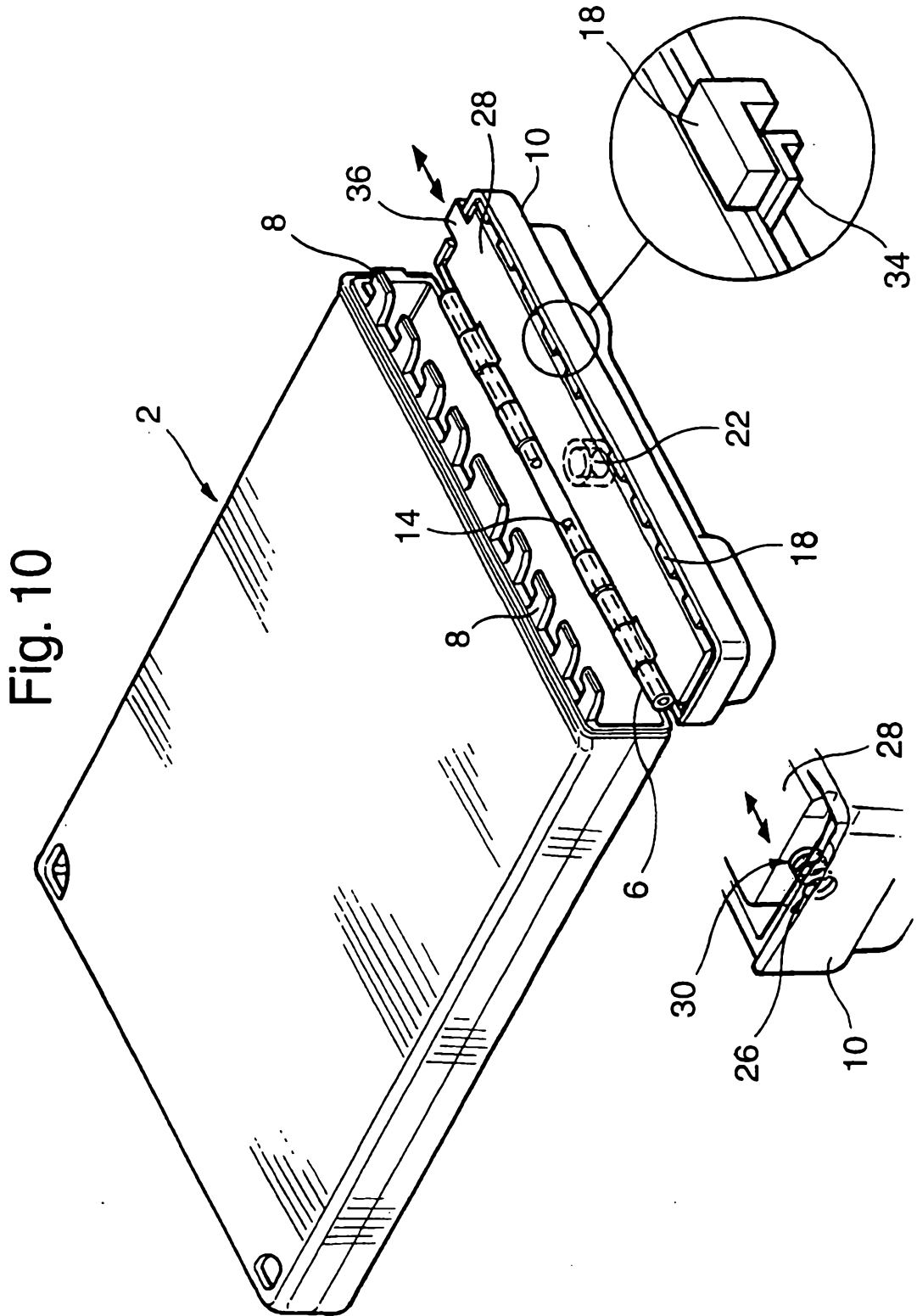

Fig. 10

Fig. 11

Fig. 12

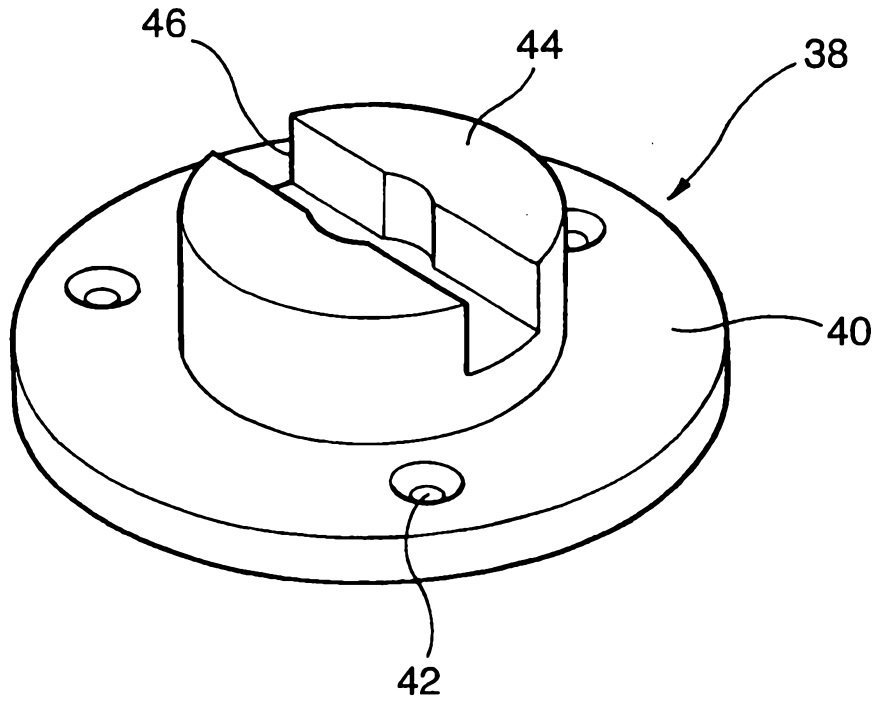

Fig. 13