

(12) STANDARD PATENT
(19) AUSTRALIAN PATENT OFFICE

(11) Application No. **AU 2021240291 B2**

(54) Title
HARD-SHELL LUGGAGE SYSTEMS

(51) International Patent Classification(s)
A45C 5/00 (2006.01) **A45C 5/06** (2006.01)
A45C 5/03 (2006.01) **A45C 5/14** (2006.01)
A45C 5/04 (2006.01)

(21) Application No: **2021240291** (22) Date of Filing: **2021.10.01**

(43) Publication Date: **2021.10.28**

(43) Publication Journal Date: **2021.10.28**

(44) Accepted Journal Date: **2023.07.06**

(62) Divisional of:
2020239694

(71) Applicant(s)
JRSK, Inc.

(72) Inventor(s)
Korey, Stephanie;Rubio, Jennifer;Recor, Bret;Murray, Seth;Weber, Charles;Park, Ahyoung

(74) Agent / Attorney
Pizzeys Patent and Trade Mark Attorneys Pty Ltd, PO Box 291, WODEN, ACT, 2606, AU

(56) Related Art
US 2014/0076679 A1
CN 202035634 U
CN 204336082 U

ABSTRACT

Improvements in luggage systems that better address the ways in which many people like to travel, in a style they feel most comfortable, while enjoying an unprecedented level of convenience which they will naturally welcome, while overcoming the shortcomings and drawback of prior art luggage systems, methods and technologies. Amongst such improvements are a telescopic - handle assembly supports a recharge able battery power module, a set of USB DC electrical power supply ports and a DC power recharging port configured with the rechargeable battery module, as well as compression pad subsystem and a laundry bag subsystem which cooperate to provide improved performance and reduced complexity .

2021240291 01 Oct 2021

2021240291 01 Oct 2021

APPLICANT: JRSK, INC.

TITLE OF INVENTION

HARD-SHELL LUGGAGE SYSTEMS

TECHNICAL FIELD

The present invention relates to new and improved hard-shell luggage systems for helping individuals transport their personal items through airports, terminals, and other transportation systems, while overcoming the shortcomings and drawbacks associated with prior art technologies.

BACKGROUND ARTBrief Overview of the State of Knowledge and Skill In The Art

Luggage systems have evolved greatly over the past 100 years in step with developments in transportation systems (i.e. airports, terminals, bus stations and railways, and ocean liners), electronic communication and computing technologies, and evolving consumer behaviors and lifestyles. Consequently, particular groups of travelers have developed particular sets of expectations when it comes to particular classes of travel. At the same time, manufacturers of luggage systems have worked hard to ensure their evolving lines of luggage systems and related products will meet and satisfy these evolving expectations relating to utility, functionality, aesthetics as well as beauty.

While thousands of luggage systems have been designed, developed, manufactured and sold throughout the global marketplace over the past three decades, for both carry-on and check-in luggage systems alike, there still remains, however, a great need for new and improved luggage systems that address the new ways in which many people like to travel, in styles they feel most comfortable, and with unprecedented levels of convenience which they naturally welcome.

In view, therefore, of these facts and circumstances of the global luggage system marketplace, there is a great need in the art for new and improved luggage

01 Oct 2021

2021240291

systems that that better address the ways in which many people like to travel, in a style they feel most comfortable, while enjoying an unprecedented level of convenience which they will naturally welcome, while overcoming the shortcomings and drawback of prior art luggage systems, methods and technologies.

SUMMMARY OF INVENTION

Accordingly, a primary object of the present invention is to provide improved luggage systems that that better address the ways in which many people like to travel, in a style they feel most comfortable, while enjoying an unprecedented level of convenience which they will naturally welcome, and overcoming the shortcomings and drawback of prior art luggage systems, methods and technologies.

In furtherance of this primary object, a new and improved hard-shell luggage system is provided comprising a set of four spinner wheels mounted in the four corners of a hard-shell housing assembly, wherein a telescopic-handle assembly supports a rechargeable battery power module, a set of USB-type DC electrical power supply ports and a USB-type DC power recharging port configured with the rechargeable battery module.

Another object of the present invention is to provide such a new and improved hard-shell luggage system, wherein when its telescopic handle assembly is arranged in a retracted configuration, its USB-type DC electrical power supply ports and USB-type DC power recharging port are not accessible, and when the telescopic handle assembly is arranged in a protracted configuration, the USB-type DC electrical power supply ports and the USB-type DC power recharging port are accessible for supplying electrical power to electrical power consuming devices and/or recharging the rechargeable battery module aboard the luggage system.

Another object of the present invention is to provide such a new and improved luggage system, wherein the telescopically extendable handle and rechargeable power supply assembly includes a GPS-based luggage position tracking device that is recharged with electrical power from said rechargeable battery storage module, and includes a GSM transceiver.

Another object of the present invention is to provide such a new and improved hard-shell luggage system comprising a set of four spinner wheels mounted in the four corners of the luggage system in an inset manner, and wherein its first and

second hard-shell housing portions are hinged together using the same front flexible panel structure that extends to cover the front access opening formed in the front hard-shell housing portion, providing access to a front accessible interior storage volume, isolated from the interior storage volume within the rear hard-shell housing portion, where a laptop or other electronic device can be stored in a pouch formed on the back of the front opening cover structure while traveling, while the first and second hard-shell housing portions can remain securely locked using a conventional TSA-approved combination lock assembly.

Another object of the present invention is to provide such a new and improved hard-shell luggage system, wherein the front cover flap structure is completely flush with (i.e. disposed in substantially the same plane as) the front surface of the front hard-shell housing in which the front access opening is formed, thereby allowing users to more easily access their on-the-go necessities (e.g. laptop, tablet, passport, headphones, etc.) while traveling without the ugly bulk other bags create.

Another object of the present invention is to provide such a new and improved hard-shell luggage system, wherein a compression-pad structure is fastened and strapped down to the interior volume of the rear hard-shell housing portion, so as to compress shirts, pants and other garments against the bottom surface of the rear hard-shell housing portion of the luggage system when the straps are buckled and tightened to generate compression forces between the compression pad and the bottom surface of the rear hard-shell housing portion.

Another object of the present invention is to provide such a new and improved hard-shell luggage system, wherein the compression-pad structure can be quickly unfastened and folded back away from the bottom of the rear hard-shell housing structure to reveal the interior volume of the rear hard-shell housing portion, allowing the user to access the interior storage volume of the luggage system and stack shirts, pants and other garments which are compressed when strapped down using the compression-pad structure.

Another object of the present invention is to provide such a new and improved hard-shell luggage system, wherein the front and rear hard-shell housing portions are sealable using an integrated zipper mechanism arranged in a zipped configuration, while its front cover flap can be manually opened to reveal the front access port opening formed through the top surface of the front hard-shell housing portion.

Another object of the present invention is to provide such a new and improved hard-shell luggage system, wherein a single piece of multi-ply material is used to form the hinge structure of the front and rear hard-shell housing portions of the luggage system, and as well as the flexible front cover flap structure that is used to cover the front access opening formed in the front hard-shell housing portion.

Another object of the present invention is to provide such a new and improved hard-shell luggage system, wherein the single piece of multi-ply material used to form the hinge structure of the front and rear hard-shell housing portions of the system, and flexible front cover flap structure comprises a sheet of dense flexible foam bonded to a layer of exterior fabric, a rigid plastic panel in the shape of a laptop perimeter to support the laptop sleeve and Velcro strap, and a pair of rigid plastic panels to form a hinge axis for the front and rear hard-shell housing portions, and a hinge axis for the front cover flap panel.

Another object of the present invention is to provide such a new and improved hard-shell luggage system comprising front first and rear hard-shell housing portions (i.e. shells) hinged together and sealed using its integrated zipper mechanism, a front access opening formed in the front hard-shell housing portion providing access to the interior volume of the front hard-shell housing portion bounded by its interior lining structure, a set of four spinner wheels mounted in the four corners of the luggage system, a telescopic-handle assembly supporting a USB rechargeable battery power supply, and a front cover flap structure (i) providing a hinge structure for the front and rear hard-shell housing portions, (ii) providing a front cover flap panel for the front access opening, (iii) employing a magnetic-stripe based front cover panel retention mechanism for retaining the front cover flap panel securely in place over the front access opening when arranged in its closed configuration, (iv) supporting a Velcro-locked laptop computer (or iPad) pouch on the inside of the front cover flap structure, and (v) allowing access to an interior storage volume within the front hard-shell housing portion of the luggage system, wherein the interior liner structure mounted within the interior volume of the front hard-shell housing portion supports a shallow zippered pouch for storing power adapters, memory sticks, and other items, and a divided un-zippered mesh pouch for holding items that need to be quickly grabbed during travel, such a mobile phone, bottle of water, snacks etc.

Another object of the present invention is to provide such a new and improved hard-shell luggage system comprising front and rear hard-shell housing portions

2021240291 01 Oct 2021

hinged together and sealed using a two-part zippering mechanism, wherein a front cover flap portion is disposed over a front access opening formed in the front hard-shell housing portion, and a telescopic-handle assembly is mounted in the rear hard-shell housing portion and having a base housing assembly supporting a rechargeable battery power module, a set of USB-type DC electrical power supply ports and a USB-type DC power recharging port configured with the rechargeable battery module, wherein a USB-type DC power port cover panel is hinged to a base housing component and covers the USB-type DC power ports and USB-type DC power recharging port formed in the base housing component.

Another object of the present invention is to provide a hard-shell luggage system having front and rear hard-shell housing portions hinged together using a zipper system, a telescoping handle assembly mounted within the rear hard-shell housing portion, and a set of four spinner wheels for easy mobility on a floor surface, wherein the front hard-shell portion has a molded recessed region of substantially rectangular geometry, wherein a front accessible pouch subsystem is mounted within the molded recess region and comprises (i) a substantially-planar front access panel, (ii) base portion stitched to the recessed rectangular molded portion of the front hard-shell housing portion, about the perimeter boundaries of the molded recess, (iii) a two part zipper system having first and second zipper portions connected between the front access panel, (iv) a first mesh-type pouch, made from elastic nylon material, mounted on the front panel for storing a first set of articles and objects allowing quick access during travel, (v) a second mesh-type pouch, made from elastic nylon material, mounted on the base portion, for storing a second set of articles and objects allowing quick access during travel, and (vi) an open-type pouch structure supported between the first and second mesh-type pouches, and adapted for storing a small mobile computer or iPad device.

Another object of the present invention is to provide such a new and improved hard-shell luggage system, comprising (i) a front hard-shell housing portion with a molded port for mounting a first TSA-approved combination lock assembly and a second TSA-approved combination lock assembly, (ii) a rear hard-shell housing portion with a set of molded ports for mounting the top handle structure and a side handle structure, and a molded port for mounting the base housing component of the telescoping handle and DC power supply assembly, (iii) a two-part zipper subsystem having a first zipper structure stitched to the lip portion of the opening around the

2021240291 01 Oct 2021

front hard-shell housing portion and a second zipper portion stitched to the lip portion of the opening around the rear hard-shell housing portion, (iv) a flexible cover flap structure functioning as a first hinge structure for the front and rear hard-shell housing portions, and a second hinge structure for a front cover flap panel for covering the front access opening formed in the front surface of the front hard-shell housing portion and supporting on its interior side, a pouch for storage of a laptop computer and/or other articles without opening up the front and rear hard-shell housing portions, and (v) a set of indented wheel-wells formed in each of the corners of the bottom portion of the front and rear hard-shell housing portions, for mounting a set of four spinner wheels.

Another object of the present invention is to provide such a new and improved hard-shell luggage system comprising (i) a front hard-shell housing portion, (ii) a rear hard-shell housing portion hinged to the front hard-shell housing portion, (iii) a set of four spinner wheels mounted in the front and rear hard-shell housing portions, (iv) a handle assembly for pulling the system about on its set of spinner wheels, and (v) a compression pad subsystem installed in the interior volume region of the rear hard-shell housing portion, wherein said compression pad subsystem comprises a compression pad like structure for holding a stack of shirts, pants and other garments in the interior volume region, beneath the pad structure while it is strapped down under tension using a set of buckle straps that pass through compression pad structure and are fastened to the rear hard-shell housing portion using screw or other fasteners known in the art, while a laundry bag subsystem supported at the bottom surface of the rear hard-shell housing portion is also compressed in volume using the compression-pad structure of the compression pad subsystem.

Another object of the present invention is to provide such a new and improved hard-shell luggage system comprising (i) a front hard-shell housing, (ii) a rear hard-shell housing portion hinged to the front hard-shell housing portion, (iii) a set of four spinner wheels mounted in the front and rear hard-shell housing portions, (iv) a handle assembly for pulling the system about on its set of spinner wheels, (v) a compression pad subsystem installed in the interior volume region of the rear hard-shell housing portion, and (vi) a laundry bag subsystem installed in the interior volume region of the rear hard-shell housing portion, wherein the laundry bag subsystem further comprises (i) a laundry bag component of expandable pouch-like geometry and having a capacity to store soiled clothes, and (ii) a laundry bag storage

pouch (i.e. compartment) formed between a set of wheel wells molded into the rear hard-shell housing portion of the hard-shell luggage system, for containing the laundry bag component when empty of soiled clothes and folded in a compact manner for storage in the laundry bag storage pouch.

Another object of the present invention is to provide such a new and improved hard-shell luggage system comprising (i) a front hard-shell housing, (ii) a rear hard-shell housing portion hinged to the front hard-shell housing portion, (iii) a set of four spinner wheels mounted in the front and rear hard-shell housing portions, (iv) a handle assembly for pulling the system about on its set of spinner wheels, (v) a compression pad subsystem installed in the interior volume region of the rear hard-shell housing portion, and (vi) an interior lining subsystem installed in the interior volume region of the front hard-shell housing portion, supporting an upper mesh pocket structure with a zippered access opening, and a lower mesh pocket structure with a zippered access opening.

Another object of the present invention is to provide such a new and improved hard-shell luggage system comprising (i) a front hard-shell housing portion, (ii) a rear hard-shell housing portion hinged to the front hard-shell housing portion, (iii) a set of four spinner wheels mounted in the front and rear hard-shell housing portions, (iv) a handle assembly for pulling the system about on its set of spinner wheels, and (v) a laundry bag subsystem is mounted inside the rear hard-shell housing portion between a pair of wheel wells molded in the rear hard-shell housing portion, wherein the laundry bag subsystem includes laundry bag storage pouch mounted between the wheel wells and ready to be un-zippered to reveal its pull-out and releasable laundry bag for containing soiled laundry while traveling, and releasably removed from its laundry bag storage pouch by way of a button or like fastener during laundry operations.

Another object of the present invention is to provide such a new and improved hard-shell luggage system, wherein the laundry bag subsystem also cooperates with a compression pad subsystem installed in the rear hard-shell housing portion by compressing (i) the laundry bag rolled out onto the bottom surface of the rear hard-shell housing portion and containing (in a separated manner) soiled clothes stored therein, as well as (ii) shirts, pants and other garments stacked or placed on top of the rolled-out laundry bag, using a set of compression belts with buckles and pull straps

2021240291 01 Oct 2021

that are pulled taut to create the desired degree of compression for the application at hand.

Another object of the present invention is to provide such a new and improved hard-shell luggage system, wherein the hard-shell luggage system is supported by a set of four spinner wheels mounted in the four corners of the luggage system, wherein its front and rear hard-shell housing portions are hinged together and sealed using its integrated zipper mechanism, and wherein when its telescopic-handle assembly is arranged in its retracted configuration, the handle structure is disposed over a hinged power port cover panel that conceals and protects a set of USB DC electrical power supply ports and DC power recharging port from rain, spilled fluids and debris.

Another object of the present invention is to provide a new and improved hard-shell luggage system, comprising (i) front and rear hard-shell housing portions are hinged together and sealed with its integrated zipper mechanism, (ii) set of four spinner wheels mounted in the four corners of the luggage system, (iii) a telescopic-handle assembly that can be arranged in a retracted configuration with a power port cover panel closed to conceal both its USB DC electrical power supply ports, and DC power recharging port, and also in protracted configuration where the power port cover panel can be opened to reveal both the USB DC electrical power supply ports, and DC power recharging port while the user pulls (i.e. trolleys) the luggage system around during travel, and (iv) a series of horizontally-formed, evenly spaced-apart ridges (i.e. corrugations) formed around the circumference of the front and rear hard-shell housing portions molded from durable plastic material, and up and down along the longitudinal axis of the luggage system, to provide added strength to the housing portions and create an attractive business-like appearance for its user.

Another object of the present invention is to provide a new and improved hard-shell luggage system, wherein a USB rechargeable DC battery power supply subsystem is integrated within the luggage system, and comprises (i) an AC/DC power adapter connected to a 100-120 volt (60Hz) or like AC power receptacle by way of a conventional power cord, (ii) a battery recharging circuit operably connected to the AD/DC power adapter by way of a USB or like power cord, (iii) a battery power storage module operably connected to the battery recharging circuit by way of electrical conductors, (iv) a power switching control circuit operably connected to the battery power storage module, the battery recharging circuit and the AC/DC power adapter, and also a set of USB power output ports for receiving the USB plugs of

electrically-powered devices (e.g. smartphones, laptops iPads, etc.) and supplying electrical DC power to these devices in a regulated manner.

Another object of the present invention is to provide a new and improved hard-shell luggage system, comprising (i) front and rear hard-shell housing portions hinged together and sealed with its integrated zipper mechanism, (ii) a set of four spinner wheels mounted in the four corners of the luggage system, (iii) a telescopic-handle assembly that can be arranged in a retracted configuration with a USB power port cover panel closed to conceal both its USB DC electrical power supply ports, and DC power recharging port, and also in protracted configuration where the power port cover panel can be opened to reveal both the USB DC electrical power supply ports, and DC power recharging port while the user pulls (i.e. trolleys) the luggage system around during travel, wherein while a user is pulling the luggage system along a rainy surface, while talking on a mobile phone that is being recharged with the telescopic handle assembly protracted and a USB power plug cable connected between the mobile phone and a USB power port in the luggage system, the USB power port cover panel will automatically close down on the USB power plug and unused USB power ports, so as to minimize pouring rain from seeping into the USB power ports of the luggage system.

Another object of the present invention is to provide a luggage system comprising: a front housing portion, and a rear housing portion, being hinged together to provide a luggage housing assembly and sealed using a zipper subsystem; a set of spinner wheels mounted to the luggage housing assembly; a telescopically-extendable handle and rechargeable power supply assembly mounted in the rear housing portion, and having a handle structure connected to a pair of telescopically-extending rods substantially disposed in a common plane, and arrangeable in either a retracted configuration and a protracted configuration; wherein the telescopically-extendable handle and rechargeable power supply assembly includes a base housing component supporting one or more USB-type DC electrical power supply ports and a USB-type DC power recharging port operably connected to a rechargeable battery storage module disposed substantially in the same plane as the pair of telescopically-extending rods; wherein when the handle structure is configured in the retracted configuration, the one or more USB-type DC electrical power supply ports and the USB-type DC power recharging port are disposed beneath and substantially covered by the handle structure; and wherein when the handle structure is configured in the

2021240291 01 Oct 2021

protracted configuration, the handle structure can be used to pull the luggage system around on the four spinner wheels, and the one or more USB-type DC electrical power supply ports and the USB-type DC power recharging port are accessible for supplying DC electrical power to one or more electrical power consuming devices and also recharging the rechargeable battery storage module.

Another object of the present invention is to provide a luggage system comprising: front and rear housing portions hinged together and sealed with its integrated zipper mechanism, to provide a housing assembly with indented wheel wells; a set of four spinner wheels mounted in the four indented wheel wells; and a telescopic-handle assembly mounted within the rear housing portion and having a handle structure with a pair of spaced apart telescopically-extendable rods, for pulling the luggage system on its four the spinner wheels; wherein the telescopic handle assembly includes a rechargeable battery storage module disposed substantially in the same plane as the pair of spaced apart telescopically-extendable rods, and one or more USB power ports disposed beneath the handle structure for supplying electrical power to one or more electrical power consuming devices such as a smartphone or mobile computing system, and a USB recharging port for recharging the rechargeable battery power module using an external electrical power source; wherein the telescopic handle assembly has a retracted configuration and a protracted configuration, wherein during the retracted configuration, the handle structure is disposed closely above and covering the USB power ports during power supplying operations; and wherein during the protracted configuration, the handle structure is disposed above and away from the USB power ports allowing power supplying operations, while the handle structure can be used to pull the luggage system around on the four spinner wheels.

Another object of the present invention is to provide a luggage system comprising: front and rear housing portions hinged together and sealed with an integrated zipper mechanism, to provide a housing assembly having corners with indented wheel wells; a set of spinner wheels mounted in the indented wheel wells; and a telescopic handle assembly mounted within the rear housing portion and having a handle structure with a pair of spaced apart telescopically-extendable rods, for pulling the luggage system on its the spinner wheels; wherein the telescopic handle assembly includes a rechargeable battery storage module of planar geometry disposed substantially in the same plane as the pair of spaced apart telescopically-extendable rods, one or more USB power ports disposed beneath the handle structure for

supplying electrical power to one or more electrical power consuming devices including mobile computing systems, and a USB recharging port for recharging the rechargeable battery power module using an external electrical power source.

Another object of the present invention is to provide a hard-shell luggage system comprising: a front hard-shell housing portion, and a rear hard-shell housing portion hinged together with the front hard-shell housing portion so as to form a hard-shell housing assembly having at least four corners; a set of spinner wheels mounted in the at least four corners of the hard-shell housing assembly; a compression pad subsystem installed in the rear hard-shell housing portion and including a compression-pad structure fastened and strapped down to the interior volume of the rear hard-shell housing portion using a set of compression straps; wherein the set of compression straps compress shirts, pants and other garments against the bottom surface of the rear hard-shell housing portion when the compression straps are configured and tightened to generate compression forces between the compression-pad structure and the bottom surface of the rear hard-shell housing portion; and a laundry bag subsystem supported above the bottom surface of the rear hard-shell housing portion, and including (i) a laundry bag component of expandable pouch-like geometry and having a capacity for storing soiled clothes, and (ii) a laundry bag storage pouch for containing the laundry bag component when empty of soiled clothes and folded-up and stored in the laundry bag storage pouch; wherein the laundry bag subsystem cooperates with the compression pad subsystem using the set of compression straps that are pulled taut to create a desired degree of compression so that the compression-pad structure compresses (i) the laundry bag component rolled out above the bottom surface of the rear hard-shell housing portion and containing soiled clothes stored therein, and also (ii) shirts, pants and/or other garments stacked or placed on top of the rolled-out laundry bag component.

Another object of the present invention is to provide a hard-shell luggage system comprising: a front hard shell housing portion; a rear hard-shell housing portion hinged together with the front hard-shell housing portion to form a hard-shell housing assembly having at least four corners; a set of spinner wheels mounted in the at least four corners of the hard-shell housing assembly; a laundry bag subsystem supported at the bottom surface of the rear hard-shell housing portion, and including a laundry bag component of expandable pouch-like geometry and having a capacity for storing soiled clothes, and a laundry bag storage pouch for containing the laundry bag

2021240291 01 Oct 2021

component when empty of soiled clothes and folded-up and stored in the laundry bag storage pouch; a compression pad subsystem installed in the rear hard-shell housing portion and including a compression-pad structure fastened and strapped down to the interior volume of the rear hard-shell housing portion using a set of compression straps; wherein the laundry bag subsystem cooperates with the compression pad subsystem using the set of compression straps that are pulled taut to create a desired degree of compression so that the compression-pad structure compresses (i) the laundry bag component rolled out above the bottom surface of the rear hard-shell housing portion and containing soiled clothes stored therein, and also (ii) shirts, pants and/or other garments stacked or placed on top of the rolled-out laundry bag; and wherein the set of compression straps compress shirts, pants and other garments, as well as the rolled out laundry bag component, against the bottom surface of the rear hard-shell housing portion when the compression straps are configured and tightened to generate compression forces between the compression-pad structure and the bottom surface of the rear hard-shell housing portion.

Another object of the present invention is to provide a luggage system comprising: a front housing portion; a rear housing portion hinged together with the housing portion to form a housing assembly having at least four corners; a set of spinner wheels mounted in the at least four corners of the housing assembly; a laundry bag subsystem supported at the bottom surface of the rear housing portion, and including a laundry bag component of expandable pouch-like geometry and having a capacity for storing soiled clothes, and a laundry bag storage pouch for containing the laundry bag component when empty of soiled clothes and folded-up and stored in the laundry bag storage pouch; a compression pad subsystem installed in the rear housing portion and including a compression-pad structure fastened and strapped down to the interior volume of the rear housing portion using a set of compression straps; wherein the laundry bag subsystem cooperates with the compression pad subsystem using the set of compression straps that are pulled taut to create a desired degree of compression so that the compression-pad structure compresses (i) the laundry bag component rolled out over the bottom surface of the rear housing portion and containing soiled clothes stored therein, and also (ii) shirts, pants and/or other garments stacked or placed on top of the rolled-out laundry bag; and wherein the set of compression straps compress shirts, pants and other garments, as well as the rolled out laundry bag component, against the bottom surface of the rear

housing portion when the compression straps are configured and tightened to generate compression forces between the compression-pad structure and the bottom surface of the rear housing portion.

Another object of the present invention is to provide a hard-shell luggage system, comprising: a front hard-shell housing portion and a rear hard-shell housing portion, being hinged together to provide a hard-shell luggage housing assembly having at least four corners and sealed using two-part zipper subsystem; a set of spinner wheels mounted in the at least four corners of the hard-shell luggage housing assembly; a telescopically-extendable handle and rechargeable power supply assembly mounted in the rear housing portion, and having a handle structure connected to a pair of telescopically-extending rods substantially disposed in a common plane, and arrangeable in either a retracted configuration and a protracted configuration; wherein the telescopically-extendable handle and rechargeable power supply assembly includes a base housing component supporting one or more USB-type DC electrical power supply ports and a USB-type DC power recharging port operably connected to a rechargeable battery storage module having a substantially planar geometry disposed substantially in the same plane as the pair of telescopically-extending rods; a compression pad subsystem installed in the rear hard-shell housing portion and including a compression-pad structure fastened and strapped down to the interior volume of the rear hard-shell housing portion using a set of compression straps; wherein the set of compression straps compress shirts, pants and other garments against the bottom surface of the rear hard-shell housing portion when the compression straps are configured and tightened to generate compression forces between the compression-pad structure and the bottom surface of the rear hard-shell housing portion; and a laundry bag subsystem supported at the bottom surface of the rear hard-shell housing portion, and including (i) a laundry bag component of expandable pouch-like geometry and having a capacity for storing soiled clothes, and (ii) a laundry bag storage pouch for containing the laundry bag component when empty of soiled clothes and folded-up and stored in the laundry bag storage pouch; wherein the laundry bag subsystem cooperates with the compression pad subsystem using the set of compression straps that are pulled taut to create a desired degree of compression so as to compress (i) the laundry bag component rolled out above the bottom surface of the rear hard-shell housing portion and containing soiled clothes stored therein, and also (ii) shirts, pants and/or other garments stacked or placed on

2021240291 01 Oct 2021

top of the rolled-out laundry bag component; wherein when the handle structure is configured in the retracted configuration, the one or more USB-type DC electrical power supply ports and the USB-type DC power recharging port are disposed beneath the handle structure; and wherein when the handle structure is configured in the protracted configuration, the handle structure can be used to pull the luggage system around on the spinner wheels, and the one or more USB-type DC electrical power supply ports and the USB-type DC power recharging port are accessible for supplying DC electrical power to one or more electrical power consuming devices and also for recharging the rechargeable battery storage module.

Another object of the present invention is to provide a hard-shell luggage system, comprising: a front hard-shell housing portion hingedly connected to a rear hard-shell housing portion to form a hard-shell housing assembly having a set of wheel-wells for mounting a set of four spinner wheels; telescoping handle assembly with a handle structure mounted within the rear hard-shell portion, and capable of being telescopically extended and used to pull the hard-shell system over floor surfaces; a molded recess formed the front surface of the front hard-shell portion; a front accessible panel hinged from the bottom side of the front hard-shell housing portion and supporting a storage pouch for storing a mobile computing device and/or other articles during travel; wherein the storage pouch is adapted to fit at least partially within the molded recess when the front accessible panel is arranged in a closed configuration, and wherein the storage pouch is accessible for receiving and storing the mobile computing device and/or other articles when the front accessible panel is arranged in an open configuration; and a zipper structure for zippering the front accessible panel to the front hard-shell housing portion when the front accessible panel is arranged in a closed configuration.

Another object of the present invention is to provide a hard-shell luggage system, comprising: front and rear hard-shell housing portions hinged together to form a hard-shell housing assembly and sealed using an integrated zipper mechanism; a front access opening formed in the front hard-shell housing portion providing access to a front accessible interior storage volume supported within the front hard-shell housing portion; wherein the rear hard-shell housing portion has an interior storage volume supported within the rear hard-shell housing portion, that is partitioned and closed off from the front-accessible interior storage volume; a set of four spinner wheels mounted in four corners of the hard-shell housing assembly; a telescopic-

2021240291 01 Oct 2021

handle assembly formed in the rear hard-shell housing portion; a front panel structure providing a hinged front panel for covering the front access opening; and a zipper structure for zipping together the front panel structure to the front access opening; wherein the inside surface of the front panel structure supports a storage pouch for holding a mobile pad computer during travel.

Another object of the present invention is to provide a hard-shell luggage system, comprising: a front hard shell housing portion having a front access opening, providing access to a front storage recess within the front hard-shell housing portion; a rear hard-shell housing portion hinged together with the front hard-shell housing portion to form a hard-shell housing assembly having embedded wheel wells; a set of four spinner wheels mounted in the embedded wheel wells of the hard-shell housing assembly; a two-part zipper subsystem for sealing the front and rear hard-shell housing portions; a front panel hinged to the front hard-shell housing portion for covering the front access opening providing access to the front storage recess; and a pouch formed on one of (i) the inside surface of the front panel, and (ii) the inside of the front storage recess, for storing an electronic device that can be accessed while traveling.

Another object of the present invention is to provide a hard-shell luggage system, comprising: a front hard shell housing portion having a front access opening providing access to a recessed interior volume; a rear hard-shell housing portion hinged together with the front hard-shell housing portion to form a hard-shell housing assembly having molded wheel wells; a set of four spinner wheels mounted in the molded wheel wells of the hard-shell housing assembly; wherein the front and rear hard-shell housing portions are sealed using two-part zipper subsystem; a front panel hinged to the front hard-shell housing portion for covering the front access opening, and providing access to a front accessible interior storage volume, isolated from an interior storage volume supported within the rear hard-shell housing portion; and wherein a laptop or other electronic device can be stored in a pouch formed on one of (i) the inside surface of the front panel, and (ii) the inside of the front-accessible interior storage volume, and accessed while traveling.

Another object of the present invention is to provide a hard-shell luggage system, comprising: front and rear hard-shell housing portions hinged together to form a hard-shell housing assembly having molded wheel wells, and sealed using an integrated zipper mechanism; a front access opening formed in the front hard-shell

2021240291 01 Oct 2021

housing portion providing access to an interior volume supported within the front hard-shell housing portion; a set of four spinner wheels mounted in the molded wheel wells of the hard-shell housing assembly; a telescopic-handle assembly supporting a USB rechargeable battery power supply providing one or more USB-type DC power supply ports for charging batteries aboard electrical energy consuming devices such as smartphone and mobile computing devices; a front cover panel structure providing (i) a first hinge structure for the front and rear hard-shell housing portions, and (ii) a second hinge structure for a front cover flap panel for covering the front access opening; wherein the inside surface of the front cover flap panel supports a pouch for holding a laptop or pad computer pouch during travel; wherein the front access opening provides access to the interior storage volume within the front hard-shell housing portion; and wherein an interior panel is mounted in the interior storage volume, and supporting one or more of (i) a shallow zippered pouch for storing accessories and other objects, and (ii) a mesh pouch for holding items that need to be quickly grabbed during travel.

Another object of the present invention is to provide a hard-shell luggage system comprising: a first hard-shell housing portion with a molded port for mounting a combination lock assembly; a second hard-shell housing portion with a set of molded ports for mounting the top handle structure, and a molded port for mounting a base housing component associated with a telescoping handle and DC power supply assembly; a two-part zipper subsystem for hinging together the first and second hard-shell housing portions, and sealing the first and second hard-shell housing portions and locking the same using the combination lock assembly; a flexible cover flap structure functioning as a hinge structure for the first and second hard-shell housing portions, and a cover structure for covering a front access opening formed in the front surface of the first hard-shell housing portion/component for storage of a laptop computer and/or other articles without opening up the first and second hard-shell housing portions; and a set of indented wheel-wells formed in the corners of the bottom portion of the first and second hard-shell housing portions, for mounting a set of four spinner wheels.

Another object of the present invention is to provide a hard-shell luggage system comprising: a front and rear hard-shell housing portions hinged together using a zipper system, to form a hard-shell housing assembly having molded wheel wells; a set of spinner wheels mounted in the molded wheel wells for easy mobility across

2021240291 01 Oct 2021

floor surfaces; a telescoping handle assembly mounted within the rear hard-shell housing portion, for pulling the hard-shell luggage system across floor surfaces; a molded recessed region of substantially rectangular geometry molded in the front hard-shell portion; and a front accessible pouch subsystem mounted within the molded recess region including (i) a front access panel hinged from the bottom side of the hard-shell luggage system, and having an open configuration and a closed configuration; (ii) a base portion fastened to the molded recess region; (iii) a two-part zipper subsystem having first and second zipper portions connected between the front access panel and the base portion, respectively; and (iv) a pouch structure supported on the inside surface of the front access panel, and adapted for storing a small mobile computer or computing device; wherein the pouch structure is arranged within the recessed rectangular molded portion against the base portion when the substantially-planar front access panel is arranged in the closed configuration; and wherein the pouch structure is arranged outside of the recessed rectangular molded portion, and the front access panel is disposed away from the base portion, when the substantially-planar front access panel is arranged in the open configuration.

Another object of the present invention is to provide a hard-shell luggage system comprising: a front and rear hard-shell housing portions hinged together using a zipper system, to form a hard-shell housing assembly having molded wheel wells; a set of spinner wheels mounted in the molded wheel wells for easy mobility across floor surfaces; a telescoping handle assembly mounted within the rear hard-shell housing portion, for pulling the hard-shell luggage system across floor surfaces; a molded recessed region of substantially rectangular geometry molded in the front hard-shell portion; and a front accessible pouch subsystem mounted partially within the molded recess region, and projecting above the front surface of the front hard-shell housing portion, wherein the front accessible pouch subsystem includes (i) a front access panel hinged from the bottom side of the hard-shell luggage system, and having an open configuration and a closed configuration; (ii) a base portion fastened to the molded recess region; (iii) a two-part zipper subsystem having first and second zipper portions connected between the front access panel and the base portion, respectively; (iv) a pouch structure supported on the inside surface of the front access panel, and adapted for storing a mobile computing device; and (v) a first mesh-type pouch, made from elastic material, mounted on the base portion, for storing a first set of articles and objects allowing quick access during travel; wherein the pouch

structure is arranged within the recessed rectangular molded portion against the base portion when the substantially-planar front access panel is arranged in the closed configuration; and wherein the pouch structure is arranged outside of the recessed rectangular molded portion, and the front access panel is disposed away from the base portion, when the substantially-planar front access panel is arranged in the open configuration.

Another object of the present invention is to provide a new and improved Internet-based luggage tracking system comprising (i) a packet switched communication network, (iii) a plurality of mobile luggage systems containing GPS-based position tracking devices integrated therein, and (ii) a data center with communication, application and database servers supporting real-time luggage tracking operations using mobile smartphones (e.g. iPhone, Android phone, etc.) and mobile applications installed thereon.

These and other objects of the present invention will become apparent hereinafter and in view of the appended Claims to Invention.

BRIEF DESCRIPTION OF DRAWINGS

The Objects of the Present Invention will be more fully understood when read in conjunction with the Figure Drawings, wherein:

FIG. 1A is a front perspective view of a first illustrative embodiment of the hard-shell luggage system of the present invention, wherein the hard-shell luggage system is positioned on its set of four spinner wheels mounted in the four corners of the luggage system, wherein its front and rear hard-shell housing portions are arranged in a closed configuration and sealed using its integrated zipper mechanism, and wherein its telescopic-handle assembly is arranged in its retracted configuration over the hinged power port cover panel concealing its USB DC electrical power supply ports, and DC power recharging port;

FIG. 1B is a rear perspective view of a first illustrative embodiment of the hard-shell luggage system of the present invention, wherein the hard-shell luggage system is positioned on its set of four spinner wheels mounted in the four corners of the luggage system, wherein its front and rear hard-shell housing portions are arranged in a closed configuration and sealed using its integrated zipper mechanism, and wherein its telescopic-handle assembly is arranged in its retracted configuration

over the hinged power port cover panel concealing its USB DC electrical power supply ports, and DC power recharging port;

FIG. 1C is a side perspective view of the first illustrative embodiment of the hard-shell luggage system shown in FIGS. 1A and 1B;

FIG. 1D is a rear perspective view of the first illustrative embodiment of the hard-shell luggage system shown in FIGS. 1A through 1C, wherein the hard-shell luggage system is positioned on its set of four spinner wheels mounted in the four corners of the luggage system, wherein its front and rear hard-shell housing portions are arranged in a closed configuration and sealed using its integrated zipper mechanism, wherein its telescopic-handle assembly is arranged in its retracted configuration with the hinged power port cover panel opened to reveal both its USB DC electrical power supply ports and DC power recharging port of the present invention, and wherein a mobile smartphone (e.g. Apple iPhone device) is being charged with electrical power being delivered from its USB DC power port via a USB cable connected between the phone and the USB DC power port;

FIG. 1E is a rear perspective view of the first illustrative embodiment of the hard-shell luggage system shown in FIGS. 1A through 1D, wherein the hard-shell luggage system is positioned on its set of four spinner wheels mounted in the four corners of the luggage system, wherein its front and rear hard-shell housing portions are arranged in a closed configuration and sealed using its integrated zipper mechanism, wherein its telescopic-handle assembly is arranged in its retracted configuration with the power port cover panel opened to reveal both its USB DC electrical power supply ports, and DC power recharging port of the present invention, and wherein the onboard rechargeable DC battery module is being recharged with electrical power being delivered from an AC/DC power adapter supplying DC power to the recharge power port via a USB cable connected between the DC recharge port and the AC/DC power adapter;

FIG. 1F is a front perspective view of the first illustrative embodiment of the hard-shell luggage system shown in FIGS. 1A through 1E, wherein the hard-shell luggage system is positioned on its set of four spinner wheels mounted in the four corners of the luggage system, wherein its front and rear hard-shell housing portions are arranged in a closed configuration and sealed using its integrated zipper mechanism, wherein its telescopic-handle assembly is arranged in its retracted configuration, and wherein the front cover flap structure is arranged in its open

configuration revealing (i) its Velcro-locked laptop computer (or iPad) pouch on the inside of the front cover flap structure, (ii) interior storage volume of the front hard-shell housing portion of the luggage system, including its shallow zippered pouch for storing power adapters, memory sticks, and other items, and a lower divided mesh pouch for hold items that need to be quickly grabbed such a mobile phone, bottle of water, snacks etc., and (iii) its magnetic stripe based front cover panel retention mechanism for retaining the front cover flap panel securely in place over the front access opening when arranged in its closed configuration;

FIG. 2A-1 is a front perspective view of the first illustrative embodiment of the hard-shell luggage system shown in FIGS. 1A, 1B and 1C, wherein the hard-shell luggage system is positioned on its set of four spinner wheels mounted in the four corners of the luggage system, wherein its front and rear hard-shell housing portions are arranged in an open configuration and its integrated zipper mechanism being unzipped, wherein its telescopic-handle assembly is arranged in its retracted configuration, wherein a set of mesh pockets are supported on the interior lining structure installed within the interior volume of the front hard-shell housing portion of the luggage system, and wherein the compression-pad structure is fastened and strapped down to the interior volume of the rear hard-shell housing portion so as to compress items disposed between the compression pad structure and the bottom of the rear hard-shell housing portion, which may include shirts, pants and other garments alone or stacked upon an expandable laundry bag rolled out from a laundry bag storage pouch supported between the molded wheel wells of the rear hard-shell housing portion, and filled with soiled clothes;

FIG. 2A-2 is front perspective view of the first illustrative embodiment of the hard-shell luggage system shown in FIGS. 1A, 1B and 1C, wherein the hard-shell luggage system is positioned on its set of four spinner wheels mounted in the four corners of the luggage system, wherein its first and second hard-shell housing portions are arranged in an open configuration and its integrated zipper mechanism being unzipped, wherein its telescopic-handle assembly is arranged in its retracted configuration, wherein a set of mesh pockets are supported on the interior lining installed within the interior volume of the front hard-shell housing portion of the luggage system, and wherein the fabric compression straps and buckles associated with the compression-pad subsystem are un-fastened, and the compression pad structure is folded back and away from the bottom of the rear hard-shell housing

structure to reveal the interior volume of the rear hard-shell housing portion, allowing user to access to the interior storage volume of the rear hard-shell housing portion of the luggage system where stack shirts, pants and other garments can be stacked and subsequently compressed when strapped down using the compression-pad structure of the present invention;

FIG. 2B is a first perspective view of the first illustrative embodiment of the hard-shell luggage system shown in FIGS. 1A, 1B and 1C, positioned on its set of four spinner wheels mounted in the four corners of the luggage system, wherein its front and rear hard-shell housing portions are arranged in an open configuration with its integrated zipper mechanism arranged in an unzipped configuration and revealing the interior volume of the luggage system with its interior lining removed for purposes of illustration, wherein its telescopic-handle assembly is arranged in its retracted configuration, wherein the front cover flap is closed to conceal the front access port opening formed through the top surface of the front hard-shell housing portion, and wherein the interior lining structures have been removed from both the interior storage volumetric regions of the front and rear hard-shell housing portions of the luggage system;

FIG. 2C is a second perspective view of the first illustrative embodiment of the hard-shell luggage system shown in FIGS. 1A, 1B and 1C, positioned on its set of four spinner wheels mounted in the four corners of the luggage system and looking into its interior volume, wherein its front and rear hard-shell housing portions are arranged in an open configuration with its integrated zipper mechanism arranged in an unzipped configuration, wherein its telescopic-handle assembly is arranged in its retracted configuration with its power port cover panel closed to conceal and protect both its USB DC electrical power supply ports and DC power recharging port, wherein the front cover flap is closed to conceal the front access port opening formed through the top surface of the front hard-shell housing portion, and wherein the interior lining structures have been removed from both the interior storage volumetric regions of the front and rear hard-shell housing portions of the luggage system, for purposes of illustration;

FIG. 2D is a third perspective view of the first illustrative embodiment of the hard-shell luggage system shown in FIGS. 1A, 1B and 1C, positioned on the front and rear surfaces of the front and rear hard-shell housing portions, respectively, and revealing the interior volume of the luggage system with its interior lining removed

2021240291 01 Oct 2021

for purposes of illustration, wherein its first and second hard-shell housing portions are arranged in an open configuration with its integrated zipper mechanism arranged in an unzipped configuration, wherein its telescopic-handle assembly is arranged in its retracted configuration with its power port cover panel closed to conceal both its USB DC electrical power supply ports, and DC power recharging port, wherein its front cover flap is closed to conceal the access port opening formed through the top surface of the front hard-shell housing portion;

FIG. 3A is a first front perspective view of the first illustrative embodiment of the hard-shell luggage system shown in FIGS. 1A, 1B and 1C, positioned on its set of four spinner wheels mounted in the four corners of the luggage system and revealing its total interior volume, wherein its front and rear hard-shell housing portions are arranged in a closed configuration with its integrated zipper mechanism arranged in a zipped configuration and the interior volume of the luggage system having its interior lining removed for purposes of illustration, wherein its telescopic-handle assembly is arranged in its retracted configuration with the power port cover panel closed to conceal and protect both its USB DC electrical power supply ports, and DC power recharging port, and wherein its front cover flap panel is opened to reveal the front access opening formed through the top surface of the front hard-shell housing portion, allowing user access to the interior storage volume of the front hard-shell housing portion;

FIG. 3B is a second front perspective view of the first illustrative embodiment of the hard-shell luggage system shown in FIGS. 1A, 1B and 1C, positioned on its set of four spinner wheels mounted in the four corners of the luggage system and looking into its interior volume, wherein its front and rear hard-shell housing portions are arranged in a closed configuration with its integrated zipper mechanism arranged in a zipped configuration and the interior volume of the luggage system having its interior lining removed for purposes of illustration, wherein its telescopic-handle assembly is arranged in its retracted configuration with the power port cover panel closed to conceal and protect both its USB DC electrical power supply ports, and DC power recharging port, and wherein its front cover flap panel is opened to reveal the front access opening formed through the top surface of the front hard-shell housing portion, allowing user access to the interior storage volume of the front shard-shell housing portion;

FIG. 3C is a side perspective view of the first illustrative embodiment of the hard-shell luggage system shown in FIGS. 1A, 1B and 1C, positioned on its set of four spinner wheels mounted in the four corners of the luggage system and looking into its interior volume, wherein its front and rear hard-shell housing portions are arranged in a closed configuration with its integrated zipper mechanism arranged in a zipped configuration and revealing the interior volume of the luggage system with its interior lining removed for purposes of illustration, wherein its telescopic-handle assembly is arranged in its retracted configuration with the power port cover panel closed to conceal and protect both its USB DC electrical power supply ports, and DC power recharging port, wherein its front cover flap is opened to reveal the front access port opening formed through the top surface of the front hard-shell housing portion, allowing user access to the interior storage volume of the front hard-shell housing portion;

FIG. 3D is a side perspective view of the first illustrative embodiment of the hard-shell luggage system shown in FIGS. 1A, 1B and 1C, positioned on its set of four spinner wheels mounted in the four corners of the luggage system and looking into its interior volume, wherein its front and rear hard-shell housing portions are arranged in a closed configuration with its integrated zipper mechanism arranged in a zipped configuration and the interior volume of the luggage system having its interior lining removed for purposes of illustration, wherein its telescopic-handle assembly is arranged in its retracted configuration with the power port cover panel closed to conceal and protect both its USB DC electrical power supply ports, and DC power recharging port, wherein its front cover flap is opened to reveal the front access opening formed through the top surface of the front hard-shell housing portion, allowing user access to the interior storage volume of the front hard-shell housing portion;

FIG. 3E is a top view of the first illustrative embodiment of the hard-shell luggage system shown in FIGS. 1A, 1B and 1C, positioned on its set of four spinner wheels mounted in the four corners of the luggage system, wherein its front and rear hard-shell housing portions are arranged in a closed configuration with its integrated zipper mechanism arranged in a zipped configuration, wherein its telescopic-handle assembly is arranged in its retracted configuration, wherein its front cover flap panel is opened to reveal the front access opening formed through the top surface of the

front hard-shell housing portion, allowing user access to the interior storage volume of the front hard-shell housing portion;

FIG. 3F is a bottom view of the first illustrative embodiment of the hard-shell luggage system shown in FIGS. 1A, 1B and 1C, positioned on the top surface of the luggage system, wherein its front and rear hard-shell housing portions are arranged in a closed configuration with its integrated zipper mechanism arranged in a zipped configuration, wherein its telescopic-handle assembly is arranged in its retracted configuration, wherein its front cover flap panel is opened to reveal the access port opening formed through the top surface of the front hard-shell housing portion, allowing user access to the interior storage volume of the front hard-shell housing portion;

FIG. 4A is an elevated front view of the first illustrative embodiment of the hard-shell luggage system shown in FIGS. 1A, 1B and 1C, positioned on its set of four spinner wheels mounted in the four corners of the luggage system, wherein its first and second hard-shell housing portions are arranged in a closed configuration with its integrated zipper mechanism arranged in a zipped configuration, and wherein the flexible front cover flap panel is folded back to reveal (i) the laptop pouch provided on the interior side of the front cover flap panel and the magnetic-based front cover flap retention mechanism provided to releasably retain the front cover flap in its closed configuration over the front access opening, and (ii) the front access opening of the front hard-shell housing portion and the shallow zippered pouch supported on the upper portion of the interior lining structure mounted within the interior storage volume of the front hard-shell housing portion of the luggage system, and the unzipped and divided mesh pouches supported on the lower portion of the interior lining structure mounted therein;

FIG. 4B is a plan view of the inner component used to construct the flexible front cover flap panel structure of the illustrative embodiment, shown comprising a sheet of dense flexible foam bonded to (i) a rigid plastic panel in the shape of a laptop perimeter to support a laptop sleeve/pouch, and (ii) and a pair of rigid spaced-apart plastic panels riveted to the sheet of dense flexible foam, forming a hinge line for the flexible cover flap panel and a hinge line for the hard-shell housing portions when the front cover flap panel structure is mounted to the recessed side regions of the front and rear hard-shell housing portions of the luggage system as shown in FIGS. 3D, 5C, 5E, 5G, 5H, 6A, and 6C;

FIG. 4C is a perspective view illustrating the multi-ply construction of the flexible front cover flap structure formed by mounting the inner component described in FIG. 4B between (i) a layer of outer fabric, and (ii) a layer of dense neoprene foam in the shape of the laptop sleeve, and a layer of inner fabric, into which a Velcro-closed laptop pocket or sleeve is sewn, in a manner overlying the perimeter outlines of the neoprene foam layer and rigid plastic sheet, to provide stiffness and protection to a laptop held in the laptop sleeve, as shown in FIG. 4D;

FIG. 4D is a plan view of the flexible front cover flap structure of the illustrative embodiment of the present invention shown fully assembled and removed from the front hard-shell housing portion, supporting a laptop sleeve/pocket adapted for holding a suitably sized laptop or pad computer therein, using a manually-releasable Velcro-based strip structure;

FIG. 5A is a first exploded perspective view of the first illustrative embodiment of the hard-shell luggage system shown in FIGS. 1A, 1B and 1C, shown comprising (i) a set of four spinner wheels mounted in the four corners of the luggage system, (ii) front and rear hard-shell housing portions, (iii) a front cover flap panel structure mounted to the recessed side panel regions of the front and rear hard-shell housing portions providing a hinge structure for the front and rear hard-shell housing portions and a front cover flap panel for covering a front access opening formed in the front hard-shell housing portion, (iv) telescopic handle and USB DC power supply assembly having a telescopic handle base assembly supporting a rechargeable battery power module, a set of USB DC electrical power supply ports and a DC power recharging port configured with the rechargeable battery module, (v) a two-part zipper subsystem and associated TSA-approved combination lock subassembly for sealing and securing the front and rear hard-shell housing portions when arranged in a closed configuration, and (vi) a set of top and side handles for carrying the luggage system in one of two possible configurations (i.e. upright carrying configuration or side carrying configuration);

FIG. 5B is a first exploded side view of the first illustrative embodiment of the hard-shell luggage system shown in FIGS. 1A through 2A-2, showing the components described in FIG. 5A from different perspectives;

FIG. 5C is a second exploded side view of the first illustrative embodiment of the hard-shell luggage system shown in FIGS. 1A through 2A-2, showing the components described in FIG. 5A from different perspectives;

2021240291 01 Oct 2021

FIG. 5D is a second exploded perspective view of the first illustrative embodiment of the hard-shell luggage system shown in FIGS. 1A through 2A-2, showing the components described in FIG. 5A from different perspectives;

FIG. 5E is a third exploded perspective view of the first illustrative embodiment of the hard-shell luggage system shown in FIGS. 1A through 2A-2, showing the components described in FIG. 5A from different perspectives;

FIG. 5F is a fourth exploded perspective view of the first illustrative embodiment of the hard-shell luggage system shown in FIGS. 1A through 2A-2, showing the components described in FIG. 5A from different perspectives;

FIG. 5G is a fifth exploded perspective view of the first illustrative embodiment of the hard-shell luggage system shown in FIGS. 1A through 2A-2, showing the components described in FIG. 5A from different perspectives;

FIG. 5H is a sixth exploded perspective view of the first illustrative embodiment of the hard-shell luggage system shown in FIGS. 1A through 2A-2, showing the components described in FIG. 5A from different perspectives;

FIG. 5I is a seventh exploded side perspective view of the first illustrative embodiment of the hard-shell luggage system shown in FIGS. 1A through 2A-2, showing the components described in FIG. 5A from different perspectives;

FIG. 5J1 is a first front perspective view of the telescopic handle and USB DC power supply assembly of the present invention shown removed from the first illustrative embodiment of the hard-shell luggage system shown in FIGS. 1A through 2A-2, and comprising (i) a manually-releasable handle portion containing an internal lock and release mechanism triggered by a manually-depressible button located centrally on the handle portion, (ii) a base housing component having a set of spaced apart telescoping guide tubes, through which a set of telescoping rod members pass and connect on one end to mounting apertures formed in the handle portion, and on the other end to mounting apertures formed in a telescopic rod member mounting bracket mountable to the surface of the rear hard-shell housing portion of the luggage system, (iii) a set of USB DC power supply ports and a DC battery recharging port formed in the top surface of the base housing component, and operably connected to a PC board mounted in a replaceable and rechargeable DC battery power module contained in a battery module casing that is supported within the plane of and between the pair of spaced apart telescopic guide tubes, beneath the base housing portion, and (iv) a power port cover panel hinged to the base housing component for

covering the USB DC power ports and DC power recharging port formed through the top surface of the base housing component;

FIG. 5J2 is a rear perspective view of the telescopic handle and USB DC power supply assembly of the present invention shown in FIG. 5J1;

FIG. 5J3 is a second front perspective view of the telescopic handle and USB DC power supply assembly of the present invention shown in FIGS. 5J1 and 5J2;

FIG. 5J4 is an elevated side view of the telescopic handle and USB DC power supply assembly of the present invention shown in FIGS. 5J1 through 5J3;

FIG. 5J5 is a first perspective view of the underside of telescopic handle and USB DC power supply assembly of the present invention shown in FIGS. 5J1 through 5J4, with the telescopic rod members removed for purposes of illustration, showing the replaceable rechargeable DC battery power supply module;

FIG. 5J6 is a perspective view of the underside of telescopic handle and USB DC power supply assembly of the present invention shown in FIGS. 5J1 through 5J4, with the telescopic rod members removed for purposes of illustration, showing the replaceable rechargeable DC battery power supply module;

FIG. 5K1 is a perspective view of the underside of telescopic handle and USB DC power supply assembly of the present invention shown in FIGS. 5J1 through 5J4, with the telescopic rod members and hinged power port cover panel removed for purposes of illustration, showing the replaceable rechargeable DC battery power supply module and power ports of the telescopic handle and USB DC power supply assembly;

FIG. 5K2 is a perspective view of the underside of telescopic handle and USB DC power supply assembly of the present invention shown in FIGS. 5J1 through 5J4, with the telescopic rod members removed for purposes of illustration, showing the replaceable rechargeable DC battery power supply module and hinged power port cover panel concealing and sealing off the power ports from the environment;

FIG. 6A is a first front perspective view of the hard-shell housing assembly employed in the first illustrative embodiment of the hard-shell luggage system shown in FIGS. 1A, 1B and 1C, in a closed and assembled manner, disposed on its side surface, and comprising (i) a front hard-shell housing portion with a molded port for mounting a first TSA-approved combination lock assembly for use in locking the two-part zipper subsystem, and a second TSA-approved combination lock for use in locking the front cover flap panel when arranged in its closed configuration, (ii) a rear

2021240291 01 Oct 2021

hard-shell housing portion with a set of molded ports for mounting the top handle structure, a molded port for mounting the base housing component of the telescoping handle and DC power supply assembly, (iii) a two-part zipper subsystem and associated lock subassembly, (iv) a two-part zipper subsystem cooperating with the associated TSA-approved combination lock subassembly, (v) a flexible cover flap structure functioning as a hinge structure for the front and rear hard-shell housing portions, and a cover structure for covering the front access opening formed in the front surface of the front hard-shell housing portion/component for storage of a laptop computer and/or other articles without opening up the front and rear hard-shell housing portions, and (vi) a set of indented wheel-wells formed in each of the corners of the bottom portion of the front and second hard-shell housing portions, for mounting a set of four spinner wheels;

FIG. 6B is a second top end perspective view of the hard-shell housing assembly employed in the first illustrative embodiment of the hard-shell luggage system shown in FIGS. 1A, 1B and 1C, in a closed and assembled manner, disposed on its side surface, and shown comprising the elements described in FIG. 6A;

FIG. 6C is a second front perspective view of the hard-shell housing assembly employed in the first illustrative embodiment of the hard-shell luggage system shown in FIGS. 1A, 1B and 1C, in a closed and assembled manner, disposed on its bottom end surface, and shown comprising the elements described in FIG. 6A;

FIG. 6D is a first rear perspective view of the hard-shell housing assembly employed in the first illustrative embodiment of the hard-shell luggage system shown in FIGS. 1A, 1B and 1C, in a closed and assembled manner, disposed on its rear surface, and shown comprising the elements described in FIG. 6A;

FIG. 6E is a bottom perspective view of the hard-shell housing assembly employed in the first illustrative embodiment of the hard-shell luggage system shown in FIGS. 1A, 1B and 1C, in a closed and assembled manner, disposed on its top end surface, and shown comprising the elements described in FIG. 6A;

FIG. 7A is a schematic illustration providing a front view of the compression pad subsystem of the present invention installed in the interior volume region of the rear hard-shell housing portion, shown comprising a compression pad like structure for holding a stack of shirts, pants and other garments in the interior volume region, beneath the pad structure, while it is strapped down under tension using two spaced-apart sets of male-female snap-together-type releasable buckle straps that pass

through loops sewn or otherwise formed in the compression pad structure and are anchored (on both ends) to the rear hard-shell housing portion using screws or other fasteners known in the art, while a laundry bag subsystem supported at the bottom of the rear hard-shell housing portion is also compressed in volume using the compression-pad structure of the compression pad subsystem;

FIG. 7B is a schematic representation illustrating the rear view of the compression pad structure employed in the compression pad subsystem illustrated in FIG. 7A, showing a perimeter extending lip or ridge extending about the compression-pad structure to maintain shirts, slacks and other stacked items from slipping around while tightening the compression straps of the compression pad subsystem of the present invention;

FIG. 8A is a schematic illustration of the rear hard-shell facing side of the interior lining subsystem installed in the interior volume region of the front hard-shell housing portion, showing an upper mesh pocket structure with a zippered access opening for storing clothing and other goods, and a lower mesh pocket structure with a zippered access opening for storing clothing and other goods during travel;

FIG. 8B is a schematic illustration of the front access opening facing side of the interior lining subsystem installed in the interior volume region of the front hard-shell housing portion, showing an upper shallow zippered pocket structure for storing items such as power supplies, memory sticks, pens, and other items, and a lower divided un-zippered mesh pocket structure for storing items such as water bottles, snacks and other others allowing quick access during travel;

FIG. 9A is a schematic illustration of the laundry bag component of the laundry bag subsystem of the present invention, for fold and roll-up storage within a laundry bag storage pouch (i.e. compartment) formed between the wheel-wells molded into the rear hard-shell housing portion of the luggage system;

FIG. 9B is a schematic illustration providing a side view of the laundry bag component shown stuffed with some soiled clothes, to illustrative its expandable pouch-like geometry and capacity to store soiled clothes;

FIG. 9C is a schematic illustration providing a perspective view of a portion of the rear hard-shell housing component, wherein the laundry bag storage pouch is ready to be un-zippered to reveal its pull-out and releasable laundry bag for containing soiled laundry while traveling;

FIG. 9D is a schematic illustration providing a perspective view of a portion of the rear hard-shell housing component, showing the laundry bag storage pouch opened and revealing a button or like structure in the storage pouch to releasably engage the tab formed on the pull-out and releasable laundry bag;

FIG. 9E is a schematic illustration providing a perspective view of a portion of the rear hard-shell housing component, showing the laundry bag storage pouch opened and the tab portion of the pull-out and releasable laundry bag component being releasably connected to the button or like structure in the storage pouch;

FIGS. 9F and 9G illustrate the buttoning of the tab on the laundry bag being connected to the button in the storage pouch;

FIGS. 10A, 10B, 10C and 10D illustrate the four steps employed when folding-up, rolling-up and packing away the laundry bag component its zippered storage pouch, starting with the emptied laundry bag rolled out and extended about the bottom of the rear hard-shell housing component, and ending up folded and rolled-up and packed away in the zippered laundry bag storage compartment;

FIG. 11A is a first front perspective view of a second illustrative embodiment of the hard-shell luggage system of the present invention, wherein the hard-shell luggage system is positioned on its set of four spinner wheels mounted in the four corners of the luggage system, wherein its front and rear hard-shell housing portions are arranged in a closed configuration and sealed using its integrated zipper mechanism, and wherein its telescopic-handle assembly is arranged in its retracted configuration over the hinged cover panel concealing its USB DC electrical power supply ports and DC power recharging port;

FIG. 11B is a second front perspective view of the second illustrative embodiment of the hard-shell luggage system shown in FIG. 11A, wherein the hard-shell luggage system is positioned on its set of four spinner wheels mounted in the four corners of the luggage system, wherein its front and second hard-shell housing portions are arranged in a closed configuration and sealed using its integrated zipper mechanism, and wherein its telescopic-handle assembly is arranged in its retracted configuration over the hinged cover panel concealing its USB DC electrical power supply ports and DC power recharging port;

FIG. 11C is an elevated front view of the second illustrative embodiment of the hard-shell luggage system shown in FIG. 11A, wherein the hard-shell luggage system is positioned on its set of four spinner wheels mounted in the four corners of

the luggage system, wherein its front and second hard-shell housing portions are arranged in a closed configuration and sealed using its integrated zipper mechanism, and wherein its telescopic-handle assembly is arranged in its retracted configuration over the hinged cover panel concealing its USB DC electrical power supply ports and DC power recharging port;

FIG. 11D is a rear perspective view of the second illustrative embodiment of the hard-shell luggage system shown in FIG. 11A, wherein the hard-shell luggage system is positioned on its set of four spinner wheels mounted in the four corners of the luggage system, wherein its front and rear hard-shell housing portions are arranged in a closed configuration and sealed using its integrated zipper mechanism, and wherein its telescopic-handle assembly is arranged in its retracted configuration over the hinged cover panel concealing its USB DC electrical power supply ports and DC power recharging port;

FIG. 11E is a bottom view of the second illustrative embodiment of the hard-shell luggage system shown in FIG. 11A, wherein the hard-shell luggage system is positioned on top surface, wherein its front and rear hard-shell housing portions are arranged in a closed configuration and sealed using its integrated zipper mechanism, and wherein its telescopic-handle assembly is arranged in its retracted configuration over the hinged cover panel concealing its USB DC electrical power supply ports and DC power recharging port;

FIG. 12A is a first perspective view of the second illustrative embodiment of the hard-shell luggage system shown in FIG. 11A, positioned on the front and rear surfaces of the first and second hard-shell housing portions, respectively, and looking inside into the interior volume of the luggage system, wherein its front and rear hard-shell housing portions are arranged in an open configuration with its integrated zipper mechanism arranged in an unzipped configuration, with the interior lining structures removed from both the interior storage volumetric regions of the front and rear hard-shell housing portions of the luggage system for purposes of illustration, wherein its telescopic-handle assembly is arranged in its retracted configuration with the power port cover panel closed to conceal both its USB DC electrical power supply ports, and DC power recharging port;

FIG. 12B is a second perspective view of the second illustrative embodiment of the hard-shell luggage system shown in FIG. 11A, showing the components from different perspectives;

FIG. 12C-1 is front perspective view of the second illustrative embodiment of the hard-shell luggage system shown in FIGS. 11A through 11E, wherein the hard-shell luggage system is positioned on its set of four spinner wheels mounted in the four corners of the luggage system, wherein its front and rear hard-shell housing portions are arranged in an open configuration and its integrated zipper mechanism being un-zipped, wherein a set of mesh pockets are supported on the interior lining installed within the interior volume of the front hard-shell housing portion of the luggage system, and wherein the compression-pad structure is fastened and strapped down to the interior volume of the rear hard-shell housing portion, so as to compress between the compression pad structure and the bottom of the rear hard-shell housing portion, (i) shirts, pants and other garments stacked upon (ii) an expandable laundry bag rolled out from a laundry bag storage pouch supported on the molded wheel wells of the rear hard-shell housing portion, and filled with soiled clothes;

FIG. 12C-2 is front perspective view of the second illustrative embodiment of the hard-shell luggage system shown in FIGS. 11A through 11E, wherein the hard-shell luggage system is positioned on its set of four spinner wheels mounted in the four corners of the luggage system, wherein its front and rear hard-shell housing portions are arranged in an open configuration and its integrated zipper mechanism being un-zipped, wherein a set of mesh pockets are supported on the interior lining installed within the interior volume of the front hard-shell housing portion of the luggage system, and wherein the compression-pad structure is un-fastened and folded back away from the bottom of the rear hard-shell housing structure to reveal the interior volume of the rear hard-shell housing portion, allowing user to access to the interior storage volume of the luggage system and stack shirts, pants and other garments to be compressed when strapped down using the compression-pad structure of the present invention;

FIG. 13A is a front perspective view of the third illustrative embodiment of the hard-shell luggage system of the present invention, wherein the hard-shell luggage system is positioned on its set of four spinner wheels mounted in the four corners of the luggage system, wherein its front and rear hard-shell housing portions are arranged in an closed configuration with its integrated zipper mechanism arranged in a zipped configuration, wherein its telescopic-handle assembly is arranged in its retracted configuration with the power port cover panel closed to conceal both its USB DC electrical power supply ports, and DC power recharging port, and wherein

the front and rear hard-shell housing portions of the luggage system have a series of horizontally-formed, evenly spaced-apart ridges (i.e. corrugations) formed around the circumference of the front and rear hard-shell housing portions molded from durable plastic material, and up and down along the longitudinal axis of the luggage system, as shown, to provide added strength to the housing portions and create an attractive business-like appearance for its user;

FIG. 13B is a rear perspective view of the third illustrative embodiment of the hard-shell luggage system of the present invention shown in FIG. 13A, showing the components of the system from a different perspective;

FIG. 13C is an elevated front view of the third illustrative embodiment of the hard-shell luggage system of the present invention shown in FIGS. 13A through 13B, showing the components of the system from a different perspective;

FIG. 13D is an elevated rear view of the third illustrative embodiment of the hard-shell luggage system of the present invention shown in FIGS. 13A through 13C showing the components of the system from a different perspective;

FIG. 13E is a top view of the third illustrative embodiment of the hard-shell luggage system of the present invention shown in FIGS. 13A through 13D, showing the components of the system from a different perspective;

FIG. 13F is a bottom view of the third illustrative embodiment of the hard-shell luggage system of the present invention shown in FIGS. 13A through 13E, showing the components of the system from a different perspective;

FIG. 13G is a first elevated side view of the third illustrative embodiment of the hard-shell luggage system of the present invention shown in FIGS. 13A through 13F, showing the components of the system from a different perspective;

FIG. 13H is a second elevated side view of the third illustrative embodiment of the hard-shell luggage system of the present invention shown in FIG. 13A, showing the components of the system from a different perspective;

FIG. 14A is a front perspective view of a fourth illustrative embodiment of the hard-shell luggage system of the present invention, wherein the hard-shell luggage system is positioned on its set of four spinner wheels mounted in the four corners of the luggage system, wherein the front cover flap panel is shown configured to cover and close off the front access opening formed in the front hard-shell housing portion and its front and rear hard-shell housing portions are arranged in a closed configuration and sealed using its integrated zipper mechanism, and wherein its

telescopic-handle assembly is arranged in its retracted configuration over the hinged power port cover panel concealing its USB DC electrical power supply ports, and DC power recharging port;

FIG. 14B is a rear perspective view of a fourth illustrative embodiment of the hard-shell luggage system of the present invention, wherein the front cover flap panel is shown configured to cover and close off the front access opening formed in the front hard-shell housing portion and its front and rear hard-shell housing portions are arranged in a closed configuration and sealed using its integrated zipper mechanism, and wherein its telescopic-handle assembly is arranged in its retracted configuration over the hinged power port cover panel concealing its USB DC electrical power supply ports, and DC power recharging port;

FIG. 14C is a side perspective view of the fourth illustrative embodiment of the hard-shell luggage system shown in FIGS. 14A and 14B;

FIG. 14D is a rear perspective view of the fourth illustrative embodiment of the hard-shell luggage system shown in FIGS. 14A through 14C, wherein the front cover flap panel is configured to cover and close off the front access opening formed in the front hard-shell housing portion and its front and rear hard-shell housing portions are arranged in a closed configuration and sealed using its integrated zipper mechanism, wherein its telescopic-handle assembly is arranged in its protracted configuration with the hinged power port cover panel opened to reveal both its USB DC electrical power supply ports and DC power recharging port of the present invention, and wherein a mobile smartphone (e.g. Apple iPhone device) is being charged with electrical power being delivered from its USB DC power port via a USB cable connected between the phone and the USB DC power port;

FIG. 14E is a rear perspective view of the fourth illustrative embodiment of the hard-shell luggage system shown in FIGS. 14A through 14D, wherein the front cover flap panel is shown configured to cover and close off the front access opening formed in the front hard-shell housing portion and its front and rear hard-shell housing portions are arranged in a closed configuration and sealed using its integrated zipper mechanism, wherein its telescopic-handle assembly is arranged in its protracted configuration with the power port cover panel opened to reveal both its USB DC electrical power supply ports, and DC power recharging port of the present invention, and wherein the onboard rechargeable DC battery module is being recharged with electrical power being delivered from an AC/DC power adapter

supplying DC power to the recharge power port via a USB cable connected between the DC recharge port and the AC/DC power adapter;

FIG. 14F is a bottom front perspective view of the fourth illustrative embodiment of the hard-shell luggage system shown in FIGS. 14A through 14E, wherein the front cover flap panel is shown hinged to the bottom of the front hard-case housing portion and configured to cover and close off the front access opening formed in the front hard-shell housing portion and its front and rear hard-shell housing portions are arranged in a closed configuration and sealed using its integrated zipper mechanism;

FIG. 14G is a front perspective view of the fourth illustrative embodiment of the hard-shell luggage system shown in FIGS. 14A through 14F, wherein the front cover flap panel is shown hinged to the bottom of the front hard-case housing portion and configured to cover and close off the front access opening formed in the front hard-shell housing portion, and its front and rear hard-shell housing portions are arranged in a closed configuration and sealed using its integrated zipper mechanism;

FIG. 14H1 is a front perspective view of the fourth illustrative embodiment of the hard-shell luggage system shown in FIGS. 14A through 14F, wherein its front and rear hard-shell housing portions are arranged in a closed configuration and sealed using its integrated zipper mechanism, and wherein the front cover flap structure is arranged in its open configuration revealing (i) interior storage volume of the front hard-shell housing portion of the luggage system, including its shallow zippered pouch for storing power adapters, memory sticks, and other items, and (ii) its magnetic stripe based front cover panel retention mechanism for retaining the front cover flap panel securely in place over the front access opening when arranged in its closed configuration;

FIG. 14H2 is a side perspective view of the fourth illustrative embodiment of the hard-shell luggage system shown in FIGS. 14A through 14H1, wherein its front and rear hard-shell housing portions are arranged in a closed configuration and sealed using its integrated zipper mechanism, and wherein the front cover flap structure is arranged in its open configuration revealing (i) interior storage volume of the front hard-shell housing portion of the luggage system, including its shallow zippered pouch for storing power adapters, memory sticks, and other items, and (ii) its magnetic stripe based front cover panel retention mechanism for retaining the front

cover flap panel securely in place over the front access opening when arranged in its closed configuration;

FIG. 14I1 is a front perspective view of the fourth illustrative embodiment of the hard-shell luggage system shown in FIGS. 14A through 14H2, wherein its front and rear hard-shell housing portions are arranged in a closed configuration and sealed using its integrated zipper mechanism, and wherein the front cover flap structure is arranged in its open configuration revealing (i) its Velcro-locked laptop computer (or iPad) pouch on the inside of the front cover flap structure, (ii) interior storage volume of the front hard-shell housing portion of the luggage system, including its shallow zippered pouch for storing power adapters, memory sticks, and other items, and a lower divided mesh pouch for hold items that need to be quickly grabbed such a mobile phone, bottle of water, snacks etc., and (iii) its magnetic stripe based front cover panel retention mechanism for retaining the front cover flap panel securely in place over the front access opening when arranged in its closed configuration;

FIG. 14I2 is a front side perspective view of the fourth illustrative embodiment of the hard-shell luggage system shown in FIGS. 14A through 14H2, wherein its front and rear hard-shell housing portions are arranged in a closed configuration and sealed using its integrated zipper mechanism, and wherein the front cover flap structure is arranged in its open configuration revealing (i) its Velcro-locked laptop computer (or iPad) pouch on the inside of the front cover flap structure, (ii) interior storage volume of the front hard-shell housing portion of the luggage system, including its shallow zippered pouch for storing power adapters, memory sticks, and other items, and a lower divided mesh pouch for hold items that need to be quickly grabbed such a mobile phone, bottle of water, snacks etc., and (iii) its magnetic stripe based front cover panel retention mechanism for retaining the front cover flap panel securely in place over the front access opening when arranged in its closed configuration;

FIG. 15A1 is front perspective view of the fourth illustrative embodiment of the hard-shell luggage system shown in FIGS. 14A through 14I2, wherein its front and rear hard-shell housing portions are arranged in an open configuration and its integrated zipper mechanism are un-zipped, wherein a set of mesh pockets are supported on the interior lining structure installed within the interior volume of the front hard-shell housing portion of the luggage system, and wherein the compression-pad structure is fastened and strapped down to the interior volume of the rear hard-

shell housing portion so as to compress items disposed between the compression pad structure and the bottom of the rear hard-shell housing portion, which may include shirts, pants and other garments alone or stacked upon an expandable laundry bag rolled out from a laundry bag storage pouch supported between the molded wheel wells of the rear hard-shell housing portion, and filled with soiled clothes;

FIG. 15A2 is front perspective view of the fourth illustrative embodiment of the hard-shell luggage system shown in FIGS. 14A, 14B and 14C, wherein its first and second hard-shell housing portions are arranged in an open configuration and its integrated zipper mechanism are un-zipped, wherein a set of mesh pockets are supported on the interior lining installed within the interior volume of the front hard-shell housing portion of the luggage system, and wherein the fabric compression straps and buckles associated with the compression-pad subsystem are un-fastened, and the compression pad structure is folded back and away from the bottom of the rear hard-shell housing structure to reveal the interior volume of the rear hard-shell housing portion, allowing user to access to the interior storage volume of the rear hard-shell housing portion of the luggage system where stack shirts, pants and other garments can be stacked and subsequently compressed when strapped down using the compression-pad structure of the present invention;

FIG. 15B1 is a first perspective view of the fourth illustrative embodiment of the hard-shell luggage system shown in FIGS. 14A, 14B and 14C, positioned on its set of four spinner wheels mounted in the four corners of the luggage system, wherein its front and rear hard-shell housing portions are arranged in an open configuration with its integrated zipper mechanism arranged in an unzipped configuration and revealing the interior volume of the luggage system with its interior lining removed for purposes of illustration, wherein its telescopic-handle assembly is arranged in its retracted configuration, wherein the front cover flap is closed to conceal the front access port opening formed through the top surface of the front hard-shell housing portion, and wherein the interior lining structures have been removed from both the interior storage volumetric regions of the front and rear hard-shell housing portions of the luggage system;

FIG. 15B2 is a second perspective view of the fourth illustrative embodiment of the hard-shell luggage system shown in FIGS. 14A, 14B and 14C, wherein its front and rear hard-shell housing portions are arranged in an open configuration with its integrated zipper mechanism arranged in an unzipped configuration, wherein its

telescopic-handle assembly is arranged in its retracted configuration, wherein the front cover flap is closed to conceal the front access port opening formed through the top surface of the front hard-shell housing portion, and wherein the interior lining structures have been removed from both the interior storage volumetric regions of the front and rear hard-shell housing portions of the luggage system, for purposes of illustration;

FIG. 16A is a front perspective view of a fifth illustrative embodiment of the hard-shell luggage system of the present invention, wherein the hard-shell luggage system is positioned on its set of four spinner wheels mounted in the four corners of the luggage system, wherein its front and rear hard-shell housing portions are arranged in a closed configuration and sealed using its integrated zipper mechanism, and wherein its telescopic-handle assembly is arranged in its retracted configuration over the hinged power port cover panel concealing its USB DC electrical power supply ports, and DC power recharging port;

FIG. 16B is a rear perspective view of a fifth illustrative embodiment shown in FIG. 16A, wherein its front and rear hard-shell housing portions are arranged in a closed configuration and sealed using its integrated zipper mechanism, and wherein its telescopic-handle assembly is arranged in its protracted configuration over the hinged power port cover panel concealing its USB DC electrical power supply ports, and DC power recharging port;

FIG. 16C is a side perspective view of the fifth illustrative embodiment of the hard-shell luggage system shown in FIGS. 16A and 16B;

FIG. 16D is a rear perspective view of the fifth illustrative embodiment of the hard-shell luggage system shown in FIGS. 16A through 16C, wherein its front and rear hard-shell housing portions are arranged in a closed configuration and sealed using its integrated zipper mechanism, wherein its telescopic-handle assembly is arranged in its protracted configuration with the hinged power port cover panel opened to reveal both its USB DC electrical power supply ports and DC power recharging port of the present invention, and wherein a mobile smartphone (e.g. Apple iPhone device) is being charged with electrical power being delivered from its USB DC power port via a USB cable connected between the phone and the USB DC power port;

FIG. 16E is a rear perspective view of the fifth illustrative embodiment of the hard-shell luggage system shown in FIGS. 16A through 16D, wherein its front and

rear hard-shell housing portions are arranged in a closed configuration and sealed using its integrated zipper mechanism, wherein its telescopic-handle assembly is arranged in its protracted configuration with the power port cover panel opened to reveal both its USB DC electrical power supply ports, and DC power recharging port of the present invention, and wherein the onboard rechargeable DC battery module is being recharged with electrical power being delivered from an AC/DC power adapter supplying DC power to the recharge power port via a USB cable connected between the DC recharge port and the AC/DC power adapter;

FIG. 16F is a front perspective view of the fifth illustrative embodiment of the hard-shell luggage system shown in FIGS. 16A through 16E, wherein its front and rear hard-shell housing portions are arranged in a closed configuration and sealed using its integrated zipper mechanism, wherein its telescopic-handle assembly is arranged in its retracted configuration, and wherein the front cover flap structure is arranged in its closed configuration;

FIG. 16G is a front bottom perspective view of the fifth illustrative embodiment of the hard-shell luggage system shown in FIGS. 16A through 16F, wherein the front cover flap panel is shown being hinged from the bottom of the hard-shell housing assembly of the present invention;

FIG. 16H is a front perspective view of the fifth illustrative embodiment of the hard-shell luggage system shown in FIGS. 16A through 16G, wherein its telescopic-handle assembly is arranged in its retracted configuration, and wherein the front cover flap panel is being opened partially to reveal through its front access opening, the interior storage volume of the front hard-shell housing portion of the luggage system and its shallow zippered pouch for storing power adapters, memory sticks, and other items, and a lower divided mesh pouch for hold items that need to be quickly grabbed such a mobile phone, bottle of water, snacks etc., and also its magnetic stripe based front cover panel retention mechanism for retaining the front cover flap panel securely in place over the front access opening when arranged in its closed configuration;

FIG. 16I is a side perspective view of the fifth illustrative embodiment of the hard-shell luggage system shown arranged in FIG. 16H;

FIG. 16J is a front perspective view of the fifth illustrative embodiment of the hard-shell luggage system shown in FIGS. 16A through 16E, wherein its telescopic-handle assembly is arranged in its retracted configuration, and wherein the front cover

flap structure is arranged in its partially opened configuration revealing (i) interior storage volume of the front hard-shell housing portion of the luggage system, (ii) its Velcro-locked laptop computer (or iPad) pouch on the inside surface of the interior lining structure, and (iii) its magnetic stripe based front cover panel retention mechanism for retaining the front cover flap panel securely in place over the front access opening when arranged in its closed configuration;

FIG. 16K1 is a front perspective view of the fifth illustrative embodiment of the hard-shell luggage system shown in FIGS. 16A through 16E, wherein its telescopic-handle assembly is arranged in its retracted configuration, and wherein the front cover flap structure is arranged in its fully opened configuration revealing (i) interior storage volume of the front hard-shell housing portion of the luggage system, including its shallow zippered pouch for storing power adapters, memory sticks, and other items, and a lower divided mesh pouch for hold items that need to be quickly grabbed such a mobile phone, bottle of water, snacks etc., (ii) its Velcro-locked laptop computer (or iPad) pouch on the inside surface of the interior lining structure, below the shallow zippered pouch, and (iii) its magnetic stripe based front cover panel retention mechanism for retaining the front cover flap panel securely in place over the front access opening when arranged in its closed configuration;

FIG. 16K2 is a front side perspective view of the fifth illustrative embodiment of the hard-shell luggage system shown and arranged in FIG. 16K1;

FIG. 17A1 is a front perspective view of the fifth illustrative embodiment of the hard-shell luggage system shown in FIGS. 16A, 16B and 16C, wherein the hard-shell luggage system is positioned on its set of four spinner wheels mounted in the four corners of the luggage system, wherein its front and rear hard-shell housing portions are arranged in an open configuration and its integrated zipper mechanism being un-zipped, wherein a set of mesh pockets are supported on the interior lining structure installed within the interior volume of the front hard-shell housing portion of the luggage system, and wherein the compression-pad structure is fastened and strapped down to the interior volume of the rear hard-shell housing portion so as to compress items disposed between the compression pad structure and the bottom of the rear hard-shell housing portion, which may include shirts, pants and other garments alone or stacked upon an expandable laundry bag rolled out from a laundry bag storage pouch supported between the molded wheel wells of the rear hard-shell housing portion, and filled with soiled clothes;

FIG. 17A2 is front perspective view of the fifth illustrative embodiment of the hard-shell luggage system shown in FIGS. 14A, 14B and 14C, wherein the hard-shell luggage system is positioned on its set of four spinner wheels mounted in the four corners of the luggage system, wherein its first and second hard-shell housing portions are arranged in an open configuration and its integrated zipper mechanism being un-zipped, wherein a set of mesh pockets are supported on the interior lining installed within the interior volume of the front hard-shell housing portion of the luggage system, and wherein the fabric compression straps and buckles associated with the compression-pad subsystem are un-fastened, and the compression pad structure is folded back and away from the bottom of the rear hard-shell housing structure to reveal the interior volume of the rear hard-shell housing portion, allowing user to access to the interior storage volume of the rear hard-shell housing portion of the luggage system where stack shirts, pants and other garments can be stacked and subsequently compressed when strapped down using the compression-pad structure of the present invention;

FIG. 18A is a first perspective view of the fifth illustrative embodiment of the hard-shell luggage system shown in FIGS. 17A, 17B and 17C, positioned on its set of four spinner wheels mounted in the four corners of the luggage system, wherein its telescopic-handle assembly is arranged in its retracted configuration, wherein the front cover flap panel is closed to conceal the front access port opening formed through the top surface of the front hard-shell housing portion, wherein its front and rear hard-shell housing portions are arranged in an open configuration with its integrated zipper mechanism arranged in an unzipped configuration and revealing the interior volume of the luggage system with its interior lining removed for purposes of illustration, and wherein the interior lining structures have been removed from both the interior storage volumetric regions of the front and rear hard-shell housing portions of the luggage system;

FIG. 18B is a second perspective view of the fifth illustrative embodiment of the hard-shell luggage system shown in FIGS. 17A, 17B and 17C, positioned on its set of four spinner wheels mounted in the four corners of the luggage system and looking into its interior volume, wherein its front and rear hard-shell housing portions are arranged in an open configuration with its integrated zipper mechanism arranged in an unzipped configuration, wherein its telescopic-handle assembly is arranged in its retracted configuration, and wherein the interior lining structures have been removed

from both the interior storage volumetric regions of the front and rear hard-shell housing portions of the luggage system, for purposes of illustration;

FIG. 19A is a front perspective view of the sixth illustrative embodiment of the hard-shell luggage system of the present invention, positioned on its set of four spinner wheels mounted in the four corners of the luggage system and looking into its interior volume, wherein its front and rear hard-shell housing portions are arranged in an open configuration with its integrated zipper mechanism arranged in an unzipped configuration, wherein its telescopic-handle assembly is arranged in its retracted configuration, and wherein its front panel flap panel shown in its closed configuration is hinged from the bottom portion of the hard-shell housing assembly and sealed using a two-part zipper subsystem mounted about the front access opening and the interior inside surface of the front cover flap panel, and also a magnetic strip front flap retention subsystem;

FIG. 19B is a front perspective view of the sixth illustrative embodiment of the hard-shell luggage system shown in FIG. 19A, wherein its front flap panel is shown in its fully opened configuration and hinged from the bottom portion of the hard-shell housing assembly;

FIG. 20A is a first perspective view of the seventh illustrative embodiment of the hard-shell luggage system of the present invention, positioned on its set of four spinner wheels mounted in the four corners of the luggage system and looking into its interior volume, wherein its front and rear hard-shell housing portions are arranged in an closed configuration with its integrated zipper mechanism arranged in a zipped configuration, wherein its telescopic-handle assembly is arranged in its retracted configuration, and wherein its front-accessible recessed zippered storage pouch is shown in its closed configuration, hinged from the bottom portion of the hard-shell housing assembly, and sealed using a two-part zipper subsystem mounted about the front access opening formed in the front-accessible recessed zippered storage pouch;

FIG. 20B is a second perspective view of the seventh illustrative embodiment of the hard-shell luggage system of FIG. 20A, positioned on its set of four spinner wheels mounted in the four corners of the luggage system and looking into its interior volume, wherein its front and rear hard-shell housing portions are arranged in an closed configuration with its integrated zipper mechanism arranged in a zipped configuration, wherein its telescopic-handle assembly is arranged in its retracted configuration, and wherein its front-accessible recessed zippered storage pouch is

2021240291 01 Oct 2021

shown in its closed configuration, hinged from the bottom portion of the hard-shell housing assembly, and sealed using the two-part zipper subsystem mounted about the front access opening formed in the front-accessible recessed zippered storage pouch;

FIG. 20C is a third perspective view of the seventh illustrative embodiment of the hard-shell luggage system of FIG. 20A, positioned on its set of four spinner wheels mounted in the four corners of the luggage system and looking into its interior volume, wherein its front and rear hard-shell housing portions are arranged in an closed configuration with its integrated zipper mechanism arranged in an zipped configuration, wherein its telescopic-handle assembly is arranged in its retracted configuration, and wherein its front-accessible recessed zippered storage pouch is shown in its open configuration, with its two-part zipper subsystem unzipped about the front access opening formed in the front-accessible recessed zippered storage pouch, revealing (i) a substantially-planar front access panel, (ii) base portion stitched to the recessed rectangular molded portion of the front hard-shell housing portion, about the perimeter boundaries of the molded recess, (iii) a two part zipper system having first and second zipper portions connected between the front access panel, (iv) a first mesh-type pouch, made from elastic nylon material, mounted on the front panel for storing a first set of articles and objects allowing quick access during travel, (v) a second mesh-type pouch, made from elastic nylon material, mounted on the base portion, for storing a second set of articles and objects allowing quick access during travel, and (vi) an open-type pouch structure supported between the first and second mesh-type pouches, and adapted for storing a small mobile computer or iPad device;

FIG. 20D is a fourth perspective view of the seventh illustrative embodiment of the hard-shell luggage system of FIG. 20A, positioned on its set of four spinner wheels mounted in the four corners of the luggage system and looking into its interior volume, wherein its front and rear hard-shell housing portions are arranged in an closed configuration with its integrated zipper mechanism arranged in an zipped configuration, wherein its telescopic-handle assembly is arranged in its retracted configuration, and wherein its front-accessible recessed zippered storage pouch is shown in its open configuration, with its two-part zipper subsystem unzipped about the front access opening formed in the front-accessible recessed zippered storage pouch, revealing (i) a substantially-planar front access panel, (ii) base portion stitched to the recessed rectangular molded portion of the front hard-shell housing portion, about the perimeter boundaries of the molded recess, (iii) a two part zipper system

having first and second zipper portions connected between the front access panel, (iv) a first mesh-type pouch, made from elastic nylon material, mounted on the front panel for storing a first set of articles and objects allowing quick access during travel, (v) a second mesh-type pouch, made from elastic nylon material, mounted on the base portion, for storing a second set of articles and objects allowing quick access during travel, and (vi) an open-type pouch structure supported between the first and second mesh-type pouches, and adapted for storing a small mobile computer or iPad device;

FIG. 20E is a fourth perspective view of the seventh illustrative embodiment of the hard-shell luggage system of FIG. 20A, positioned on its set of four spinner wheels mounted in the four corners of the luggage system and looking into its interior volume, wherein its front and rear hard-shell housing portions are arranged in an closed configuration with its integrated zipper mechanism arranged in an zipped configuration, wherein its telescopic-handle assembly is arranged in its retracted configuration, and wherein its front-accessible recessed zippered storage pouch is shown in its open configuration, with its two-part zipper subsystem unzipped about the front access opening formed in the front-accessible recessed zippered storage pouch, revealing (i) a first mesh-type pouch mounted on the flexible front panel for storing a first set of articles and objects allowing quick access during travel, (ii) a pouch with foldable gussets for storing a small mobile computer or iPad device, and (iii) a second mesh-type pouch for storing a second set of articles and objects allowing quick access during travel;

FIG. 20F is a perspective view of the front hard-shell housing portion of the seventh illustrative embodiment of the hard-shell luggage system of FIG. 20A, wherein a rectangular recess is formed (e.g. molded) for mounting the front-accessible recessed zippered storage pouch, preferably made from leather or software plastic material, sewn into the recess about its perimeter boundaries, as shown in FIG. 20H;

FIG. 20G is a plan view of the zippered storage pouch preferably made from leather or software plastic material, sewn into the recess about its perimeter boundaries, as shown in FIG. 20H;

FIG. 20H is an plan view of the rear side of the front hard-shell housing portion of the seventh illustrative embodiment of the hard-shell luggage system of FIG. 20A, showing back portion of the molded rectangular recess to which the front-accessible recessed zippered storage pouch is sewn into the recess about its perimeter boundaries, as shown in FIG. 20H;

2021240291 01 Oct 2021

FIG. 21 is a block-type schematic diagram representative of the USB rechargeable DC battery power supply subsystem integrated within the luggage systems of the present invention, and shown comprising (i) an AC/DC power adapter connected to a 100-120 Volt (60Hz) or like AC power receptacle by way of a conventional power cord, (ii) a battery recharging circuit operably connected to the AD/DC power adapter by way of a USB or like power cord, (iii) a battery power storage module operably connected to the battery recharging circuit by way of electrical conductors, (iv) a power switching control circuit operably connected to the battery power storage module, the battery recharging circuit and the AC/DC power adapter, and also a set of USB power output ports for receiving the USB plugs of electrically-powered devices (e.g. smartphones, laptops iPads, etc.) and supplying electrical DC power to these devices in a regulated manner; and

FIG. 22 is a block system diagram of the Internet infrastructure supporting packet switched communication amongst (i) a plurality of mobile luggage systems of the present invention containing GPS-based position tracking devices integrated therein, and (i) a data center with communication, application and database servers supporting real-time luggage tracking operations using mobile smartphones (e.g. iPhone, Android phone, etc.) and mobile applications installed thereon.

DESCRIPTION OF EMBODIMENTS

Referring to the accompanying Drawings, like structures and elements shown throughout the figures thereof shall be indicated with like reference numerals.

Specification Of The Carry-On Luggage System Of The First Illustrative Embodiment Of The Present Invention

Referring to FIGS. 1A through 10A, the carry-on luggage system of the first illustrative embodiment of the present invention 1 will now be described in detail.

As shown in FIGS. 1A through 1E, the hard-shell luggage system of the first illustrative embodiment 1 is positioned on its set of four double-spinner wheels 2A through 2D mounted in the four corners of the luggage system. As shown, its front and rear hard-shell housing portions (i.e. molded components) 3A and 3B are arranged in a closed configuration and sealed using its integrated zipper mechanism 4. Its ~~The~~ telescopic-handle assembly 4 is arranged in its protracted configuration over

the hinged power port cover panel 5 concealing its USB DC electrical power supply ports 6A and 6B, and its DC power recharging port 7. In the preferred embodiment, the physical dimensions of the carryon luggage system are about 22x14x9 inches which is the maximum carry-on size allowed for all major US-based carriers including Delta, United, and American Airlines. In alternative embodiments, these dimensions may vary to meet the application at hand.

As shown in FIG. 1D, the telescopic-handle assembly 22 is arranged in its protracted configuration with the hinged power port cover panel 5 opened to reveal both its USB DC electrical power supply ports 6A and 6B and DC power recharging port 7, while a mobile smartphone (e.g. Apple iPhone device) 8 is being charged with electrical power being delivered from a USB DC power supplying ports 6A, 6B via a USB cable 9 connected between the phone 9 and the USB DC power supplying ports 6A, 6B. In this protracted configuration, where the power port cover panel is opened providing access to the USB DC electrical power supply ports, the user can pull (i.e. trolleys) the luggage system around during travel while holding the mobile smartphone. In the event that the user is pulling the luggage system along a rainy surface (e.g. while talking on a mobile phone that is being recharged), the hinged power port cover panel 5 will automatically close down on the USB power plug in power supplying port 6A and unused USB power supplying port 6B, so as to prevent rain from seeping into the USB power ports of the luggage system and prevent electrical shock or shorting.

As shown in FIG. 1E, the telescopic-handle assembly 22 is arranged in its protracted configuration with the hinged power port cover panel 5 opened to reveal both its USB DC electrical power supply ports 6A and 6B and DC power recharging port 7, while its onboard rechargeable DC battery module 22B1 is being recharged with electrical power being delivered from an AC/DC power adapter 11 supplying DC power to the recharge power port 7 via a USB cable 12 connected between the DC recharge port 7 and the AC/DC power adapter 11. The details of the battery discharging and recharging operations will be described in greater detail hereinafter with reference to FIGS. 1E, 5A and 14.

As shown in FIG. 1F, the front cover flap structure 13 is arranged in its open configuration revealing: (i) a Velcro-locked laptop computer (or iPad) pouch 14 on the inside of the front cover flap structure 5; (ii) the interior storage volume 15 of the front hard-shell housing portion 3A of the luggage system including an interior lining

structure 29 supporting on its front side, a shallow zippered pouch 16 with zipper 16A for storing power adapters, memory sticks, and other items, and a divided mesh pouch 17 with elastic banding 17A, for holding items that need to be quickly grabbed such a mobile phone, bottle of water, snacks etc.; and (iii) a magnetic-stripe based front cover flap panel retention mechanism 17A employing a set of powerful magnetic strips 18A and 18B on the underside of the front cover flap panel 13, and a corresponding set of magnetic strips 18A' and 18B' on the edge 20 of the front access opening 19, for retaining the front cover flap panel 13 securely in place over the front access opening 19 when arranged in its closed configuration.

To open the front cover flap panel 13, the user only needs to gently pry back the pliant lip portion 13A of the front cover flap panel 13 at its central location, and pull the front cover flap panel 13 away from the magnetic strips 18A' and 18B' mounted along the inside edge surface 20 about the front access opening 19 against the magnetic attraction forces generated by the permanent magnet strips 18A and 18B used to realize the front panel cover flap retention system 18. To lock the front cover flap panel 13 closed, a TSA-approved combination lock assembly 21 is mounted through a port 51 formed in the front hard-shell housing portion 3A, adjacent the edge of edge of the front access opening 19, opposite the front cover flap hinge line 22. The combination lock assembly 21 includes a mechanism for rotating a clasp-like lock member 26 that engages with locking member 27 mounted to the interior surface of the edge of the front cover flap panel 13, when the user locks the front cover flap panel 13 arranged in its closed configuration, as shown in FIG. 1A. At any time, such as when being away from the carry-on luggage system, or checking the luggage piece with a luggage handling system, the user can quickly lock the front cover flap panel 13 using a preset lock combination. The lock combination can be changed at any time within a few seconds of time, in a manner known in the art.

As shown in FIG. 2A-1, the hard-shell luggage system 1 is positioned on its set of four spinner wheels 2A through 2D mounted in the four corners of the luggage system 1, and its first and second hard-shell housing portions 3A and 3B are hinged together and arranged in an open configuration with its integrated zipper mechanism 4 being un-zipped. The telescopic-handle assembly 22 is arranged in its protracted configuration. As shown, a set of mesh pockets 28A and 28B are supported on the interior lining 29 installed within the interior volume 30 of the front hard-shell housing portion 3A of the luggage system. Also, a compression-pad structure 32A is

2021240291 01 Oct 2021

fastened and strapped down to the interior volume of the rear hard-shell housing portion 3B by a set of hand-tightened belt-buckles 33A and 33B anchored to the rear hard-shell housing portion through its interior lining 34 installed in the rear hard-shell housing portion 3B. The primary function of the compression pad structure 32A is to compress the following items located between the compression pad structure 32A and the bottom surface of the rear hard-shell housing portion 3B: (i) shirts, pants and other garments stacked upon (ii) an expandable laundry bag 36A rolled out from a laundry bag storage pouch 36C supported on the molded wheel wells 3B1 and 3B2 of the rear hard-shell housing portion 3B, and filled with soiled clothes 37 through zippered access opening 36A1. The compression pad subsystem 32 and the laundry bag subsystem 36 which are integrated in the rear hard-shell housing portion 3B will be described in greater detail hereinafter.

As shown in FIG. 2A-2, the compression-pad structure 32A is un-fastened and folded back away from the bottom of the rear hard-shell housing structure to reveal the interior volume of the rear hard-shell housing portion 3B and its interior lining 39. In this configuration, the user is allowed to access to the interior storage volume of the luggage system and (i) roll out the expandable laundry bag 36A from its laundry bag storage pocket 36B as illustrated in FIGS. 9A through 9G, fill it with soiled clothes to be laundered, then zipper it up, and then (ii) stack shirts, pants and other garments 37 on top of the filled and zipped up laundry bag 36A, for compression when the compression-pad 32A structure is strapped down using the associated straps and buckles 32C and 32D.

FIGS. 2B through 2D show the hard-shell luggage system with its front and rear hard-shell housing portions 3A and 3B arranged in an open configuration with its integrated zipper mechanism arranged in an unzipped configuration, and its interior lining structures 29 and 39 have been removed from both the interior storage volumetric regions of the front and rear hard-shell housing portions of the luggage system. As shown, the front cover flap 13 is closed to conceal the front access port opening 19 formed through the top surface of the front hard-shell housing portion 3A. As shown the telescoping handle and rechargeable power supply assembly 22 is revealed as being mounted to the bottom surface of the rear hard-shell housing portion 3B. The details on this mounting arrangement will be described in greater detail hereinafter.

When the interior lining structure 29 is installed in the front hard-shell housing portion 3A as shown in FIG. 2A-1, the interior storage volume of the front hard-shell housing portion 3A is essentially closed off and isolated from the interior storage volume of the rear hard-shell housing portion 3B, and is made accessible to the luggage user only from the front access opening 19 when the front flap 13 is opened. Also, as shown in FIG. 2A-1, the interior lining structure 29 installed in the front hard-shell housing portion 3A supports mesh pockets 17B and 17C for storing garments and other accessories. The mesh pockets can be made of a strong nylon material, with elastic banding, allowing the user to quickly see what is stored in which mesh pocket at a glance.

Referring to FIGS. 3A through 6E, the construction of the carry-on luggage system of the first illustrative embodiment will be described in greater detail.

As shown in FIGS. 3A through 3F, the hard-shell luggage system 3B comprises: (i) front and rear hard-shell housing portions 3A and 3B molded from a thermoplastic such as 100% virgin polycarbonate; (ii) a set of four spinner wheels 2A, 2B, 2C and 2D mounted in the four corners of the luggage system, in inset wheel wells 3A1, 3A2, 3B1 and 3B2 respectively, formed in the front and rear hard-shell housing portions 3A and 3B; (iii) a front cover flap structure 13 disposed over a slightly recessed front access opening 19 formed in the first hard-shell housing portion 3A so that the cover flap portion 13 covers the front access opening 19 in a flush manner (i.e. the front cover flap portion 13 resides within substantially the same plane as the front surface of the front hard-shell housing portion 3A when the front flap portion is in its closed configuration shown in FIGS. 1A, 2C, 2D, 6A, 6C, and 6E); (iv) a telescopic-handle and rechargeable power supplying assembly 22 including (a) a telescopic handle base housing assembly 22B supporting a rechargeable battery power module 22D1 mounted in a battery module casing 22D2 closed with a cover 22D3, a PC board 22B3 supporting USB connectors 6A', 6B', 7', a set of USB DC electrical power supplying ports 6A and 6B and a DC power recharging port 7 configured with the rechargeable battery module 22D1 via the PC circuit board and battery mounting receptacle 22B4 as illustrated in FIGS. 5A and 14, and (b) a telescopic handle subassembly including a manually-releasable handle structure 22A with release button 22E, and telescoping rods 22C1' and 22C2', guided within guide tubes 22C1 and 22C2, respectively, and having at least three selectable lengths for different size users; (v) a two-part zipper subsystem 4 having zipper

2021240291 01 Oct 2021

components 4A and 4B stitched into and along the respective lip portions of the openings of the front and rear hard-shell housing portions 3A and 3B of the luggage system; (vi) a first TSA-approved combination lock subassembly 40 associated with locking together securely the zipper pull tabs 4A1 and 4A2 of the zipper components 4A and 4B, respectively, and therefore the zipper system 4; (vii) a second TSA-approved combination lock subassembly 21 associated with engaging and locking together the first connector 27 mounted on the edge of the front cover flap panel 13, and the second connector 26 associated with the inner edge portion of the front access opening 19 formed in the front hard-shell housing portion 3A; and (viii) a set of top and side handles 45 and 46 mounted through ports 47 and 48, respectively, formed in molded rear hard-shell housing portion 3B, for carrying the luggage system in one of two possible configurations (i.e. upright carrying configuration or side carrying configuration).

Referring to FIGS. 5A, and 5J1 through 5J4, the manually-releasable handle portion 22E contains an internal lock and release mechanism, installed within the elongated handle structure 22E, which is triggered by manually-depressing the manually-depressible button 22E located centrally on the handle structure 22A. Any suitable lock and release mechanism can be used to practice the present invention, and is generally known in the luggage system art. As shown, the telescopic handle subassembly 22 comprises: (i) a base housing component 22B having a set of spaced apart guide tubes 22C1' and 22C2', into which a set of telescoping rod members 22C1 and 22C1 pass and connect on one end to mounting apertures 22A1 and 22A formed in the handle portion 22A, and on the other end to mounting apertures 22F1 and 22F2 formed in a telescopic rod member mounting bracket 22F having a foot portion 22F3 that mounts to the bottom surface of the rear hard-shell housing portion 3B of the luggage system using glue or other suitable adhesive.

As shown in FIG. 5A, the base housing component 22B further comprises: an integrated receptacle 22B4 for receiving PC board 22B3 supporting GPS/GSM luggage tracking module 60, USB connectors 6A', 6B' and 6C' and circuitry illustrated in FIG. 14; USB DC power supply ports 6A and 6B and DC battery recharging port 6C allowing corresponding USB connectors 6A', 6B' and 6C' on the PC board 22B3 to extend through corresponding ports formed in the base housing component 22B and receive corresponding USB connectors associated with cables connected to mobile phones 8 and laptop computers and the AC/DC power adapter

11; and a hinged power port cover panel 5 that has soft rubber seals on its underside to plug up and seal the power ports when the hinged power port cover panel 5 is arranged in its closed configuration as shown in FIGS. 5J3 and 5K2.

As shown in FIGS. 5J1 through 5J4, a replaceable and rechargeable DC battery power module 22D1 is connected to the PC board 22B3, and contained in a battery module casing 22B2 with an end cap cover 22D3, all of which is supported within the plane of and between the pair of spaced apart telescopic guide tubes 22C1 and 22C2, beneath the base housing component or portion 22B; and (iv) a power port cover panel 5 that is hinged to the base housing component 22B, disposed between the spaced apart guide tubes 22C1 and 22C2, and covers the entire aperture 22I formed in the top surface of the base housing component 22B, through which the DC power supplying ports 6A, 6B and DC power recharging port 7 are accessible, as clearly shown in FIG. 5K1.

In the illustrative embodiment, the two USB DC power supply ports 6A, 6B are capable of charging two devices simultaneously, whereas the 1 micro USB power recharging port 7 enables the charging of the rechargeable battery module 22B. Typically, using a 10,000 mAh battery, the module will be capable of fully charging an iPhone up to five or more times. With future advances in battery technology, such battery performance characteristics are expected to improve.

Preferably, the power port cover panel 5 is spring-biased to automatically close down upon USB plug connectors inserted into the power ports for charging and/or recharging operations, and reduce exposure of the USB ports to the elements. Also, it is desired that the USB power ports 6A and 6B and 7 are recessed within the base housing component 22B so that when USB power plugs are inserted into USB power ports, and establish connection with electrical connectors on the PC board 22B3 disposed therebeneath, the hinged power port cover panel 5 can be configured in closed configuration while cables associated with charging and/or recharging operations can pass through a small channel formed in the power cover panel 5, to prevent rain, snow and other elements from entering open USB power ports while the luggage system is being transported through environments where exposure to rain and snow is inevitable.

As shown in FIGS. 6A through 6E, the front and rear hard-shell housing portions (i.e. components) are made from molded plastic and hinged together by a single multi-layer structure that functions not only a hinge for the hard-shell housing

portions 3A and 3B, but also a hinged front cover flap portion 13 that closes off the front access opening 19 formed in the front surface of the front hard-shell housing portion 3A. Together, these components form a hard-shell housing assembly that is employed in the first illustrative embodiment of the hard-shell luggage system.

As shown in FIG. 6B, the front hard-shell housing portion 3A has a molded port 50 for mounting a TSA combination lock assembly 40 associated lock subassembly associated with the two-part zipper system 4 comprising (i) a first zipper structure 4A (e.g. supplied by the YKK (Yoshida Kogyo Kabushikikaisha) Group, Tokyo, Japan or other vendor) stitched or otherwise fastened to the lip portion extending about the opening of the front hard-shell housing component 3A, (ii) a second zipper structure 4B stitched or otherwise fastened to the lip portion extending about the opening of the rear hard-shell housing component 3B, and (iii) a pair of zipper pulls 4A1 and 4B1 associated with the first and second zipper structures 4A and 4B, respectively.

As shown in FIGS. 6A, 6B and 6D, the rear hard-shell housing portion 3B has (i) a set of molded ports 47 for mounting the top handle structure 45, (ii) a set of a molded ports 48 for mounting the side handle structure 46, and (iii) a molded port 49 for mounting the base housing component 22A of the telescoping handle and DC power supply assembly 22. Preferably, the front and rear hard-shell components 3A and 3B are molded from 100% virgin polycarbonate plastic material providing both the lightest weight and durable characteristics required for modern luggage applications.

As shown in FIG. 6D, the bottom surfaces of the front and rear hard-shell portions 3A and 3B also have a set of indented wheel-wells 3A1, 3A2 and 3B1, 3B2 molded deep into each of the corners of the bottom portion of the first and second hard-shell housing portions 3A and 3B, for mounting the set of four 360 degree double-spinner wheels 2A and 2D using rivets or a strong adhesive cement. In the illustrative embodiment, the 360 degree double-spinner wheels 2A through 2D can be realized using double-spinner wheels made from 100% Makrolon materials, available from Hinomoto of Japan, although other equivalent spinner wheel components may be used with good results.

As shown in FIGS. 6A through 6E, the flexible cover flap structure 13' illustrated in FIGS. 4A through 4D serves several functions, namely: (i) as a hinge structure about axis 24 for the front and rear hard-shell housing portions 3A and 3B,

and (ii) a flexible opaque front cover flap panel 13 hinged about axis 25 for covering the front access opening 19 formed in the front surface of the first hard-shell housing portion 3A for storage of a laptop computer and. or other articles without opening up the front and rear hard-shell housing portions 3A and 3B, respectively.

In FIGS. 4A through 4D, a preferred construction for the flexible front cover panel structure 13' is illustrated in great technical detail. As shown, the multi-ply structure 13' comprises: (i) a sheet of dense flexible foam 71 bonded to a layer of exterior fabric 70; (ii) a rigid plastic panel 72A made of nylon or other materials in the shape of a laptop perimeter to support a laptop sleeve 14; (iii) a pair of rigid plastic panels 72B and 72C made of nylon riveted to the sheet of dense flexible foam, for forming, when mounted to the side of the first hard-shell housing portion, a first hinge line 24 about which the front and rear hard-shell housing portions 3A and 3B swings, and a second hinge line 25 about which the front cover flap panel 13 swings during opening and closing operations; (iv) a layer of dense neoprene foam 73 in the shape of the laptop sleeve, adhesively fixed to rigid plastic panel 72A; (v) a neoprene foam layer 74 arranged on top of plastic panels 72A, 72B, 72C and foam layer 71; and (v) a layer of inner fabric 75 upon which is supported (a) a laptop pouch 14 with a sleeve 14A for receiving and holding a suitably sized laptop or pad computer therein, and a Velcro-strap system 14B, 14C, as shown in FIG. 4C. After these components are assembled, sewn or otherwise fastened together, the flexible front cover panel structure 13' is then riveted to the slightly recessed side surface region 3A4 of the front hard-shell housing portion 3A, and also to the slightly recessed side surface region 3B4 of the rear hard-shell housing portion 3B4, as shown in FIGS. 3D, 5E, 5G and 5H. Once the flexible front cover flap structure 13' is mounted to the front and rear hard-shell housing portions 3A and 3B, the laptop sleeve/pocket 14 will be capable of supporting the weight of the stored laptop or iPad as the case may be, in almost any application.

FIGS. 5A through 5I show an exploded view of the luggage system of the first illustrative embodiment, whose components and subcomponents have been described above. While the assembly of most components can occur in different orders, different manufacturers will develop different procedures to reduce the time, energy and cost to manufacture, assemble and test luggage systems according to the present invention.

2021240291 01 Oct 2021

Referring to FIGS. 5A, 5J1 through 5J4, the telescopic handle and USB DC power supply assembly 22 is shown comprising: (i) a manually-releasable handle portion 22A containing an internal lock and release mechanism (not shown) triggered by a manually-depressible button 22E located centrally on the handle portion 22A; (ii) base housing component 22B having a set of spaced apart guide tubes 22C1 and 22C2, through which a set of telescoping rod members 22C1' and 22C2' pass and connect on one end to mounting apertures 22A1 and 22A2 formed in the handle portion 22A, and on the other end, to mounting apertures 22F1 and 22F2 formed in a telescopic rod member mounting bracket/foot 33F3 that mounts to the bottom surface of the rear hard-shell housing portion 3B of the luggage system; (iii) a set of USB DC power supply ports 6A, 6B and mini-USB DC power recharging port 7 formed in the base housing component 22B, and operably connected to a replaceable and rechargeable DC battery power module 22D1 contained in a battery module casing 22D2 and associated end cap 22D3 which is supported within the plane of and between the pair of spaced apart guide tubes 22C1 and 22C2, beneath the base housing portion 22B; and (iv) a DC power port cover panel 5 that is hinged to the base housing component 22B and covering the USB DC power ports 6A and 6B and DC power recharging port 7 formed in the base housing component 22B. As shown in FIG. 5J5, the battery module storage casing 22D2 is releasably fastened to the base housing component 22B by way of a pair of screws 22G1 and 22G2 or other fasteners to permit the battery module to be replaced as required.

Preferably, base housing component 22B, guide tubes 22C1 and 22C2, and the telescopic member mounting bracket 22F3 are molded from plastic material. Preferably, telescopic rods 22C1' and 22C2' are made from metal, carbon fiber or plastic materials exhibiting strength and resilience required by the application at hand where the user needs to pull (i.e. trolley) along the luggage system along sidewalks, up stairwells, and other pathways aboard airplanes, trains, ocean liners and other travel vessels.

Specification of the Compression-Pad Subsystem Installed Within The Rear Hard-Shell Housing Portion Of The Luggage System

Referring to FIGS. 2A-1, 2A-2, 7A and 7B, the compression pad subsystem 32 installed in the interior volume region of the rear hard-shell housing portion 3B

2021240291 01 Oct 2021

will now be described in greater technical detail. As shown, the compression pad subsystem 32 comprises: a compression pad like structure 32A and a pair of buckled straps 32C and 32D for holding (i) a stack of shirts, pants and other garments 85 in the interior volume region within the interior lining system 39 beneath the pad structure 32, (ii) a stack of shirts, pants and garments 85 resting upon directly upon a rolled-out expandable laundry bag 36A while filled with soiled clothes, while the compression pad structure 32A is strapped down under compression using the set of buckles 32C and 32D that pass through compression pad structure 32 and are anchored to the rear hard-shell housing portion 3B using screw or other fasteners known in the art. Notably, the compression pad subsystem 32 can be used alone or in combination the laundry bag subsystem 36 of the present invention supported at the bottom of the rear hard-shell housing portion 3B - also compressed in volume using the compression-pad structure of the compression pad subsystem.

As shown in FIG. 7A, each fabric strap 32C2, 32D2 has a male buckle portion 32C6, 32D6 and a female buckle portion 32C5, 32D5 which releasably engage each other in conventional manner with pressure applied to the spring-biased front surface of the male buckle component. As shown, the first fabric strap 32C2 is anchored at one end to the rear hard-shell housing portion 3B by an anchor mechanism (e.g. plastic structure) 32C4 that is cemented or riveted in place to provide a point of engagement with the anchor 32C4 by way of a screw or other fastener, while the other end of the other strap is anchored at one end to the rear hard-shell housing portion 3B (or alternatively, 3A) by an anchor mechanism (e.g. plastic structure) 32C3 that is cemented or riveted in place to provide a point of engagement with the anchor 32C3 by way of a screw or other fastener. As shown, the fabric strap 32C2 passes through a loop 32E that is sewn into the fabric of the compression pad structure 32.

As shown, the second fabric strap 32D2 is anchored at one end to the rear hard-shell housing portion 3B by an anchor mechanism (e.g. plastic structure) 32D4 that is cemented or riveted in place to provide a point of engagement with the anchor 32D4 by way of a screw or other fastener, while the other end of the other strap is anchored at one end to the rear hard-shell housing portion 3B by an anchor mechanism (e.g. plastic structure) 32D3 that is cemented or riveted in place to provide a point of engagement with the anchor 32D3 by way of a screw or other fastener.

Preferably, the compression pad structure 32 contains a very stiff plastic panel 32J about which foam and external fabric lining 32K is sewn to provide a unitary very

stiff compression pad structure that is resistant to bending and distortion when compression forces are generated by tightening the compression straps 32C and 32D. Also, as shown in FIG. 7B, the underside of the compression pad structure 32A has a ridge like structure 32G extending about the perimeter of the compression-pad structure to maintain shirts, slacks and other stacked items from shifting around while the compression pad is arranged and fastened down using the buckled straps 32C and 32D. The ridge-like structure 32G can have a height as short as a ½ inch and may extend up to a few inches in height as desired, and be compressible when the compression pad structure 32A is arranged in its compression state.

Specification of the Interior Lining Subsystem Installed Within The Front Hard-Shell Housing Portion Of The Luggage System

As shown in FIG. 8A, the front hard-shell facing side of the interior lining subsystem 29 installed in the interior volume region of the front hard-shell housing portion 3A, comprises: an upper mesh pocket structure 28A with a zippered access opening 28A1 for storing clothing and other goods; and a lower mesh pocket structure 28B with a zippered access opening 28B1 for storing clothing and other goods during travel. As shown, in the illustrative embodiment, the zippered access openings 28A1 and 28B1 are offset slightly by a small space from the edge of the lining structure, indicated by 28A2 and 28B2, respectively.

As shown in FIG. 8B, the front access opening facing side of the interior lining subsystem 29 installed in the interior volume region of the front hard-shell housing portion 3A, comprises: a shallow zippered pocket structure 16, having a zippered opening 16A with a zipper pull 16B, for storing items such as power supplies, memory sticks, pens, and other items; and a divided un-zippered mesh pocket structure 17, having an elastic opening 17A, with divided mesh pockets, for storing items such as water bottles, snacks and other others allowing quick access during travel.

Specification of the Laundry Bag Subsystem Installed Within The Rear Hard-Shell Housing Portion Of The Luggage System

Referring to FIGS. 9A through 9G, the laundry bag subsystem 36 of the present invention will now be described in greater technical detail.

2021240291 01 Oct 2021

As shown in FIG. 9A, the laundry bag component 36A of the laundry bag subsystem 36 is made from a nylon material sewn together and expandable when filled with soiled clothing through its zippered opening 36A1 shown in the drawings. Preferably, the nylon material will contain air and orders with the zippered laundry bag 36A during travel. The length and width of the laundry bag component 36A will typically be slightly less than the length and width dimensions of the bottom surface of the rear hard-shell housing portion 3B, to allow the laundry bag to be taken out of its zippered storage pouch 36B between the wheel wells 3B1 and 3B2, and unfolded and extended to lie flat on the bottom surface of the hard shell portion 3B3. Then the user fills the laundry bag 36A with soiled clothes during travel and then pulls the zipper pull tag 36A2 and zips up the bag to separate soiled clothes from fresh clean clothing. The user can then stack clean shirts, pants and other garments on the flatly extended laundry bag and then compress the entire stack and laundry bag 36A using the compression pad subsystem 32 described above. When convenient, the user removes the laundry bag component 36A from the luggage system by unbuttoning the button 36B1 sewn into the laundry bag storage pouch 36B and passing through the hole 36A4 in the tab projection 36A3, as shown in FIGS. 9D through 9G. Once detached from the laundry bag storage pouch 36B, the laundry bag 36A containing soiled clothes can be taken to an appropriate location where the clothes can be washed and/or dry cleaned in a conventional manner.

Once a user has emptied the laundry bag component 36A of soiled clothes collected during travel, typically the user will perform the following operations: (i) arrange the laundry bag 36A in a flat fashion as illustrated in FIG. 10A; (ii) then fold it up as illustrated in FIG. 10B; (iii) then roll it up as shown in FIG. 10C; and (iv) finally, stuff the folded and rolled up laundry bag 36A into the laundry bag storage pouch 36B and zipper it up as illustrated in FIG. 10D. In this state, the compression pad system 32 of the present invention will be used initially during packing operations, with only fresh clean shirts, pants and other garments, and the laundry bag subsystem 36 will be deployed and used in conjunction with the compression pad subsystem 32 as soiled clothes are produced during travel.

Specification Of The Carry-On/Check-In Luggage System Of The Second Illustrative Embodiment Of The Present Invention

2021240291 01 Oct 2021

Referring to FIGS. 11A through 12B, the carry-on/check-in luggage system of the second illustrative embodiment of the present invention will now be described in detail.

In all respects, the luggage system 1' of the second illustrative is similar to the luggage system 1 of the first illustrative embodiment with the following exceptions, specifically: the luggage system of the second illustrative embodiment 1' does not support a front access opening 19, it does not employ a flexible front cover flap panel structure 13 as used in the first illustrative embodiment, and it does not employ a second TSA-approved combination lock assembly 21. Instead, the hinge structure employed in the second illustrative embodiment 1' is realized within the dual-zipper system 4 as illustrated in FIGS. 11B, 11E, 12A and 12B. In all other respects, the luggage system of the second illustrative embodiment 1' is similar to the luggage system of the first illustrative embodiment 1.

Specification Of The Carry-On/Check-In Luggage System Of The Third Illustrative Embodiment Of The Present Invention

Referring to FIGS. 13A through 13F, the carry-on/check-in luggage system of the third illustrative embodiment 1'' of the present invention will now be described in detail below.

In all respects, the luggage system 1'' of the third illustrative embodiment is similar to the luggage system of the second illustrative embodiment 1' with the following exceptions. Specifically, the front and rear hard-shell housing portions 3A'' and 3B'' of the luggage system 1'' has a series of horizontally-formed, evenly spaced-apart ridges (i.e. corrugations) 52 formed around the circumference of the front and rear hard-shell housing portions molded from durable plastic material, and up and down along the longitudinal axis of the luggage system 1'', as shown, to provide added strength to the housing portions and create an attractive business-like appearance for its user. In all other significant respects, it is similar to the luggage system of the second illustrative embodiment.

Specification Of The Carry-On/Check-In Luggage System Of The Fourth Illustrative Embodiment Of The Present Invention

2021240291 01 Oct 2021

Referring to FIGS. 14A through 15B2, the carry-on/check-in luggage system of the fourth illustrative embodiment 1''' of the present invention will now be described in detail below.

In all respects, the luggage system 1''' of the fourth illustrative embodiment is similar to the luggage system of the second and third illustrative embodiments 1' and 1'' with the following exceptions. Specifically, the front cover panel 13''' in the fourth illustrative embodiment is mounted to the bottom surface of the front hard-shell housing portions 3A''' using its bottom mounted hinge portion 13C''', secured in position using rivets, adhesive or a combination thereof. Also the laptop pouch 14 is mounted on the inside surface of the front cover flap panel 13'''. Also in all other significant respects, it is similar to the luggage system of the second and third illustrative embodiments.

Specification Of The Carry-On/Check-In Luggage System Of The Fifth Illustrative Embodiment Of The Present Invention

Referring to FIGS. 16A through 18B2, the carry-on/check-in luggage system of the fifth illustrative embodiment 1'''' of the present invention will now be described in detail below.

In all respects, the luggage system 1'''' of the fifth illustrative embodiment is similar to the luggage system of the fourth illustrative embodiment 1''' with the following exceptions. Specifically, the laptop pouch 14'''' is mounted on the inside surface of the interior lining structure 29, below the shallow zippered pouch 16. Also the nylon mesh pouch 17'''' of mounted on the laptop pouch 14'''', and/or on the inside surface of the front cover flap panel 13'''. In all other significant respects, it is similar to the luggage system of the second and third illustrative embodiments.

Specification Of The Carry-On/Check-In Luggage System Of The Sixth Illustrative Embodiment Of The Present Invention

Referring to FIGS. 19A and 19B, the carry-on/check-in luggage system of the sixth illustrative embodiment 1''''' of the present invention will now be described in detail below.

In all respects, the luggage system 1''''' of the sixth illustrative embodiment is similar to the luggage system of the fourth and fifth illustrative embodiments 1''' and

2021240291 01 Oct 2021

1'''' with the following exceptions. In this embodiment, the luggage system of the present invention 1'''''' is modified to support a zipper-based front cover flap panel retention system 108, which may replace or be used as a supplement to a magnetic-stripe based subsystem 18, as disclosed and described hereinabove. Specifically, a zipper-based front cover flap retention/sealing subsystem 108, having zipper components 108A and 108B, is used to seal the front cover flap panel 13'''''' to the interior surface about the front access opening 19''''''. This zipper-based subsystem 108 installed by stitching zipper component 108A to the lip opening about the left side of the front access opening 19 and the left inside surface of the outer perimeter of the front cover flap panel 13'''''', and by stitching zipper component 108B to the lip opening about the right side of the front access opening 19 and the right inside surface of the outer perimeter of the front cover flap panel 13''''', as indicated in FIG. 19B. Preferably, the outer perimeter of the front cover flap panel 13'''''' is pliant to allow the edge lip portion thereof to flex and bend, especially when the zippers 108A and 108B are manually manipulated into either their closed or opened configurations by the user pulling their respective zipper pull members. Optionally, a magnetic-based front cover panel retention subsystem 18, similar to the one employed in other illustrative embodiments, can be used in combination with the zipper-based subsystem 108, as the application at hand requires. In all other significant respects, the luggage system of the sixth illustrative embodiment 1'''''' is similar to the luggage systems of the fourth and fifth illustrative embodiments of the present invention.

Specification Of The Carry-On/Check-In Luggage System Of The Seventh Illustrative Embodiment Of The Present Invention

Referring to FIGS. 20A through 20E, the carry-on/check-in luggage system of the seventh illustrative embodiment 1'''''' of the present invention will now be described in detail below.

In all respects, the luggage system 1'''''' of the seventh illustrative embodiment is similar to the luggage system of the sixth illustrative embodiments 1'''''' with the following exceptions. In this embodiment, the luggage system of the present invention 1'''''' is modified to support a zipper-based front accessible recessed computer pouch subsystem 130, mounted within a molded recess 131 formed in the front hard-shell housing portion 3A'''''', as disclosed and described hereinbelow.

Specifically, the front-accessible recessed zippered storage pouch subsystem 130 has a front panel 130A hinged from the bottom portion of the hard-shell housing assembly, having has an open and closed configuration, and sealed using the two-part zipper subsystem 133 mounted about the front access opening 130A1 formed in the front-accessible recessed zippered storage pouch subsystem 1330.

As shown in FIGS. 20A through 20E and 20G and 20H, the front-accessible recessed zippered storage pouch subsystem 130 comprises the following assembly of structures: (i) a substantially-planar front access panel 130A; (ii) base portion 130B stitched to/through the recessed rectangular molded portion 131 of the front hard-shell housing portion 3A''''''', about the perimeter boundaries of the molded recess 131, and through the rear surface of the recessed portion 132; (iii) a two part zipper system 133 having first and second zipper portions 133A, 133B connected between the front access panel 130A and base portion 130B and zipper pulls 133C1 and 133C2, respectively; (iv) a first mesh-type pouch 130C, made from elastic nylon material, mounted on the base portion 130B for storing a first set of articles and objects allowing quick access during travel; (v) a second mesh-type pouch 130D, made from elastic nylon material, mounted on the rear surface of the front panel 130A, for storing a second set of articles and objects allowing quick access during travel; and (vi) an open-type pouch structure 130E supported with foldable side gussets 130G1 and 130G2, between the first and second mesh-type pouches 130C and 130D, and adapted for storing a small mobile computer or iPad device.

In this illustrative embodiment, the front accessible recessed storage pouch 130E has a relatively low profile extending above the front surface of the front hard-shell housing portion 3A'''''''. This feature of the computing device pouch ensures that a relatively small portion of the interior storage volume of the pouch subsystem 130 is disposed above the plane of the molded recess 131 formed in the front hard-shell housing portion 3A''''''' so that a substantial portion of the interior storage volume of the pouch subsystem 130 is disposed below the plane of the molded recess 131 formed in the front hard-shell housing portion 3A'''''''. In alternative embodiments, the molded recess 131 can be manufactured with greater depth, allowing the front accessible recessed pouch to be further recessed below the plane of the molded recess 131 formed in the front hard-shell housing portion 3A'''''''.

As shown in FIGS. 20A, 20B and 20H, the front hard-shell housing portion 3A''''''' is hingedly connected to the rear hard-shell housing portion 3B''''''' to form

a hard-shell housing assembly having a set of wheel-wells 51A, 51B, 51C and 51D for mounting a set of four spinner wheels 2A, 2B, 2C, and 2C.

As shown hereinabove, the handle structure 22A of the telescoping handle assembly 22 is capable of being telescopically extended and used to pull said hard-shell system over floor surfaces.

As shown in FIGS. 20E, 20F and 20G, the front accessible panel 130 is hinged from the bottom side of the base portion 130B mounted within the molded recess 132, and supporting the storage pouch 130E for storing a mobile computing device and/or other articles during travel. As shown in FIGS. 20A 20B and 20H, the storage pouch 130E with foldable side gussets 130G1 and 130G2 is adapted to fit within the molded recess 131 when the front accessible panel 130A is arranged in a closed configuration. As shown in FIGS. 20E, 20F and 20G, the storage pouch 130E is accessible for receiving and storing a mobile computing device and/or other articles when the front accessible panel 130A is arranged in an open configuration. The zipper structures 133A, 133B are provided for zippering the front accessible hinged panel 130A to base portion 130B mounted in the front hard-shell housing portion 3A'''''' when the front accessible panel 130A is arranged in its closed configuration illustrated in FIGS. 20A, 20B and 20H.

In this illustrative embodiment, the interior volume of the pouch subsystem 130 is spatially isolated from the interior volume supported within the hard-shell luggage housing formed by the front hard-shell housing portion 3A'''''' hinged to the rear hard-shell housing portion 3B'''''''. In alternative embodiments, the recess 131 supporting the interior volume of the pouch subsystem 130 may be made very deep, to allow the pouch subsystem 130 to hold and store mobile computing devices (e.g. iPads, laptops) having deep depth dimensions (e.g. 1.0-2.5 inches). In some embodiments, the front accessible panel 130A may extend slightly above the plane of the front surface of the front heard-shell housing portion 3A''''''', while partially recessed below the front casing surface, as illustrated in FIG. 20H. In other embodiments, the front accessible panel 130A may extend substantially within the plane of the front surface of the front heard-shell housing portion 3A''''''', while the pouch structure 130E is partially recessed below the front casing surface, as illustrated in FIGS. 20A, 20B, 20E, 20F and 20G. Alternatively, the pouch subsystem 130 can be realized so that its base portion 130B is fastened (e.g. stitched to the recess surfaces 132) while the pouch structure 130E is allowed to extend outside and beyond

the volumetric extent of the recess region 131, as shown in FIG. 20H. There are various different ways to construct and configure the pouch subsystem 130 within the molded recess region 131 of the front hard-shell housing portion 3A'''''''. In one arrangement, the zippered front panel 130A can be configured so that the pouch portion 130E is attached to the base portion 130B, fastened to the bottom surface 132 of the molded recess region 131. In an alternative arrangement, the zippered front panel 130A can be configured so that the pouch portion 130E is attached to the front rear panel 130. In yet, another illustrative embodiment, as shown in FIGS. 20E, 20F and 20G, the pouch portion 130E is attached between the zippered front panel 130A and the base portion 130B by way of pliant foldable side gussets 130G1 and 130G2, as illustrated, to allow a mobile computing device stored in the pouch structure 130E to be protected in the molded recess region 131 when the front access panel 130A is arranged in its closed configuration, as shown in FIGS. 20A, 20B and 20H.

The front-accessible recessed zippered storage pouch subsystem 130 can be made using various kinds of materials such as leather, plastic and/or other kinds of suitable materials. In general, the front panel 130A, base portion 130B and pouch portion 130E are made from soft material such as leather or synthetic plastic, and stiffer material, sewn together in a conventional manner. The zipper structures 133A, 133B are also sewn to the front panel 130A and base portion using conventional sewing techniques. The first mesh-type pouch 130C, second mesh-type pouch 130D, and open-type pouch structure 130E with foldable side gussets 130G1 and 130G2, are sewn together using nylon or like thread material, to form the front-accessible recessed zippered storage pouch subsystem 130 illustrated in FIGS. 20A through 20E and 20G and 20H.

Specification Of Rechargeable Power Supply Subsystem Integrated Aboard The Luggage Systems Of The Present Invention

FIG. 21 shows the USB rechargeable battery power supply subsystem 88 of the illustrative embodiment that is integrated within the various luggage systems of the present invention disclosed herein. As shown, the USB rechargeable electrical battery power supply subsystem 88 comprises: (i) an AC/DC power adapter 11 connected to a 100 volt (60Hz) or like AC power receptacle by way of a conventional power cord 12; (ii) a battery recharging circuit 22G supported on PC board 22D3 shown in FIGS. 5J1 and 5J2, operably connected to the AD/DC power adapter 11 by

2021240291 01 Oct 2021

way of a micro-USB or like power cord; (iii) a rechargeable electrical power storage module (e.g. electro-chemical cell or battery) 22D1 operably connected to the battery recharging circuit 22G by way of electrical conductors; (iv) the GPS/GSM luggage tracking module 60 associated with the GPS/GSM luggage location tracking system illustrated in FIG. 21, and supplied DC electrical power from the rechargeable battery storage module 22D; (iv) a power switching control circuit 22H operably connected to the battery power storage module 22D1, the battery recharging circuit 22G and the AC/DC power adapter 11, and also to a set of USB power output ports 6A and 6B for receiving the USB plugs of electrically-powered devices (e.g. smartphones, laptops, iPads, etc.) 7 and supplying electrical DC power to these devices in a voltage regulated manner.

Preferably, components 22G, 22H, 6A', 6B' and 7' are realized on PC board 22B3, mounted within the base housing component 22B. While not preferred, the AC/DC power adapter 11 may be realized aboard the base housing component 22B or within the battery storage module 22D1, while providing an AC power receptacle port within the base housing component 22B under the hinged power port cover panel 5. In such an alternative embodiment, the user connects an AC power cord directly to the AC power port aboard the base housing component, and AC to DC power conversion occurs aboard the luggage system to recharge its battery storage module 22D2.

In the preferred embodiment, both the battery storage module 22B1 and the PC board 22B3 are contained or housed in casing 22D2. At any instant in time, airport safety regulations will likely impact particular design choices on whether or not battery storage devices are permitted within check-in type luggage systems, as well as carry-on type luggage systems. Therefore, in one alternative embodiment of the present invention, the rechargeable battery storage module 22D1 might be eliminated, and instead the PC board 22B3 is housed in casing 22D2. In other alternative embodiment of the present invention, the GPS/GSM tracking module 60 might be eliminated and only the battery storage module 22D1 is stored in the casing 22D2. The advantages of integrating the GPS/GSM luggage tracking module 60 within the base component of the telescoping-handle and DC power supply assembly of the present invention 22 are many, including easy recharge of device 60 from battery storage module 22D1, and reduced risk of the device 60 being removed or misappropriated from the luggage system.

Specification Of The Luggage Tracking System For Use With The Luggage Systems Of The Present Invention

In FIG. 22, an Internet-based luggage location tracking system 100 is shown for use with the luggage system of the present invention. As shown, the system 100 comprises: a plurality of mobile luggage systems 1 through 1''''', each containing a GPS/GSM-based luggage location tracking device 60 integrated within the base component 22B of the luggage system, and configured in operable communication with a system of GPS satellites 140 of a GPS system 150, and one or more GSM (or CDMA or other cellular data) communication networks 106 connected to the (TCP/IP) infrastructure of the Internet 101; a plurality of client communication devices (e.g. smartphones, mobile computers, desktop computers etc.) used by the owners of luggage seeking real-time information on the location of their luggage pieces; and a data center 102 operably connected to the infrastructure of the Internet 101, for processing data packets received from the GSM communication network 106, and plurality of client communication devices 106.

As shown in FIG. 22, each luggage system 1 through 1''''' contains a GPS/GSM-based luggage location tracking device 60 comprising a number of components preferably realized in a system-on-a-chip (SOC) architecture, namely: a GPS transceiver circuit/chip 60A for receiving GPS signals transmitted from the GPS satellites 140 of a deployed GPS system 150; an onboard programmed microprocessor 60B with memory storing program code for processing these received GPS signals in real-time to determine longitude and latitude position coordinates of the luggage piece on Earth; local memory storage 60C for storing computed position/location coordinates; a GSM transceiver 60D and antenna structure 60E for transmitting to a data center 102, electromagnetic GSM radio data signals encoded with time-stamped luggage location coordinates for reception, storage and processing within the data center 102; and a rechargeable battery storage cell 60F for providing electrical power to all such circuits and systems 60A-60E realized aboard each device 60. In some embodiments, the battery storage device 60F may be implemented as a thin-film capacitor structure embodied within the SOC package, and in other embodiments, the battery storage device 60F may be realized outside of the SOC package.

2021240291 01 Oct 2021

While the SOC-based luggage position tracking devices 60 of the illustrative embodiments is shown realized using a combination of GPS tracking and GSM communication technologies, it is understood that alternative tracking and communication technologies can be used to implement the luggage position/location tracking and communication system 100. Examples of such alternative technologies include, but are not limited to, the technologies employed in the LUG LOC® luggage locator system, or other functionally equivalent systems and devices, or any other suitable object tracking device, suitably modified for the purpose at hand.

As shown in FIG. 22, the data center 102 component of the system 100 comprises: one or more communication servers 103 supporting http, ftp and other communication protocols; application servers 104 running one or more object-oriented application programs supporting the various luggage location tracking and notification services on the system 100; and database servers 105 running RDBMS software for managing the data collected and generated by the system. In general, these server systems are configured together to process received luggage location coordinate data from luggage systems being tracked by the system 100, and supporting various real-time luggage tracking and monitoring operations of the luggage devices 1 through 1'''''' using mobile smartphones (e.g. iPhone, Android phone, etc.) with GUI-based mobile applications installed thereon, as well as mobile and desktop computers running as web-browsers to access a luggage location tracking website at which luggage owners can visit and access information about the whereabouts of their luggage pieces at any instant in the time. Using the GPS/GSM-based luggage tracking system 100, users can track the whereabouts of their luggage systems (i.e. in terms of GPS coordinates) using a mobile application supported on their smartphone, or any web browser running on any computer system, providing an added level of comfort and security knowing where ones luggage is located.

Modifications of the Illustrative Embodiments of the Present Invention

The present invention has been described in great detail with reference to the above illustrative embodiments. It is understood, however, that numerous modifications will readily occur to those with ordinary skill in the art having had the benefit of reading the present invention disclosure.

2021240291 01 Oct 2021

For example, the luggage system of the present invention 1 can be modified so that the telescopic handle and rechargeable power supply module 22 is adapted to provide one or more additional USB power supply ports mounted within the interior volume of the front hard-shell housing portion 3A (e.g. mounted on the front surface of the interior lining system 29, or on a interior wall surface of the front hard-shell housing portion 3A) so that a USB power cable can be connected to (i) this USB power extension port, and (ii) the laptop or iPad computer system that might be supported in the laptop pouch 14 (through 14''''') while the front cover flap panel 13 (through 13''''') is either opened or closed, as the case may be.

While the luggage system 1 has been described as a "carry-on" type piece of luggage piece, and luggage systems 1' through 1'''''' have been described as "carry-on/check-in" luggage pieces, it is understood that the any of these luggage systems can be used in either carry-on, check-in and/or carry-on/check-in applications and that how any such system of the present invention may be used by a user will depend on various factors including prevailing governmental regulations operating in the airline, ocean-liner, railway and other travel-related industries.

These and all other such modifications and variations are deemed to be within the scope and spirit of the present invention as defined by the accompanying Claims to Invention.

CLAIMS

The claims defining the invention are as follows:

1. A luggage system, comprising:

a luggage housing assembly comprising a front housing portion and a rear housing portion hinged together;

a set of wheels mounted to the luggage housing assembly;

a handle and rechargeable power supply assembly mounted in the rear housing portion, the handle and rechargeable power supply assembly having a handle structure connected to a pair of telescopically-extending rods substantially disposed along a common plane, the handle structure and the pair of telescopically-extending rods being arrangeable in a retracted configuration and a protracted configuration, wherein in the retracted configuration, the handle structure is disposed entirely below an upper surface of the rear housing portion;

wherein the handle and rechargeable power supply assembly includes:

a base housing component supporting one or more electrical power supply ports and a power recharging port operably connected to a rechargeable battery storage module disposed substantially along the same plane as the pair of telescopically-extending rods, the base housing component defining a recess along an upper surface exposing the one or more electrical power supply ports and the power recharging port, the recess having a first height; wherein the one or more electrical power supply ports and the power recharging port are not accessible when the handle structure is in the retracted configuration,

a battery module casing, disposed between the pair of telescopically-extending rods, mounted to or integrally formed with the base housing component, the battery module casing:

being substantially hollow and defining an internal volume: i) to receive the rechargeable battery storage module, and ii) that is open to the recess; and

having an opening through which the rechargeable battery storage module can be installed and removed; and

a power port cover panel hingedly connected to the base housing component configured to move between: i) a closed configuration to cover the one or more electrical power supply ports and the power recharging port, in which the power port cover panel is disposed within the recess defined by the base housing component, the power port cover panel having a thickness equal to said first height, such that an upper surface of the power port cover panel is substantially flush with the upper surface of the base housing component, and ii) an open configuration in which the one or more electrical power supply ports and the power recharging port are accessible through the recess defined by the base housing component.

2. The luggage system of claim 1, wherein the handle structure assembly is disposed within a rear surface of the rear housing portion

3. The luggage system of claim 1 or 2, wherein the handle and rechargeable power supply assembly further comprises:
 - a battery recharging circuit operably connected to an AC/DC power adapter by way of a power cord; and
 - a power switching control circuit operably connected to the rechargeable battery storage module, the battery recharging circuit and the AC/DC power adapter, and also the one or more electrical power supply ports for receiving the USB plugs of electrically-powered devices and supplying electrical DC power to these devices in a regulated manner.

4. The luggage system of claim 1 or 2, which is a hard-shell luggage system, wherein the front housing portion comprises a front hard-shell housing portion, wherein the rear housing portion comprises a rear hard-shell housing portion, wherein the front and rear hard-shell housing portions are hinged together to provide a hard-shell housing assembly, and wherein the handle and rechargeable power supply assembly is mounted in the rear hard-shell housing portion.

5. The luggage system of claim 1 or 2, wherein the front and rear housing portions are sealed using a zipper subsystem.

6. The luggage system of claim 1 or 2, further comprising: a set of top and side handles for carrying the luggage system in one of two possible configurations comprising an upright carrying configuration, and a side carrying configuration.

7. A luggage system comprising:
 - a housing assembly comprising a front housing portion, and a rear housing portion, hinged together and sealable to one another, the front and rear housing portions comprising indented wheel wells;
 - a set of wheels mounted in the indented wheel wells; and
 - a base housing component disposed along the rear housing portion entirely below an upper surface of the rear housing portion, the base housing component supporting one or more electrical power supply ports and a power recharging port operably connected to a rechargeable battery storage module disposed substantially along a same plane as a pair of

handle guide tubes disposed within the rear housing portion, the base housing component defining a recess along an upper surface exposing the one or more electrical power supply ports and the power recharging port, the recess having a first height;

a battery module casing, disposed between the pair of handle guide tubes, mounted to or integrally formed with the base housing component, the battery module casing:

being substantially hollow and defining an internal volume: i) to receive the rechargeable battery storage module, and ii) that is open to the recess; and

having an opening through which the rechargeable battery storage module can be installed and removed; and

a cover panel pivotably connected to the base housing component by a hinge, the cover panel configured to move between: i) a closed configuration to cover the one or more electrical power supply ports and the power recharging port, in which the cover panel has a thickness equal to the first height such that the cover panel is disposed within the recess defined by the base housing component and an upper surface of the cover panel is substantially flush with the upper surface of base housing component, and ii) an open configuration in which the electrical power supply ports and the power recharging port are accessible, and wherein the cover panel includes a channel configured to allow one or more cables associated with the electrical power supply ports and the power recharging port to access the electrical power supply ports and the power recharging port when the cover panel is in the closed configuration.

8. The luggage system of claim 7, further comprising a telescopic handle assembly mounted within the rear housing portion and having a handle structure with a pair of spaced apart telescopically-extendable rods disposed within the pair of handle guide tubes and wherein the telescopic-handle assembly is disposed entirely below an upper surface of the rear housing portion and the telescopic-handle assembly is disposed within a rear surface of the rear housing portion.

9. The luggage system of claim 7, wherein the rechargeable battery storage module-comprises: a battery recharging circuit operably connected to an AC/DC power adapter by way of a USB or like power cord.

10. The luggage system of claim 8, which is a hard-shell luggage system, wherein the front housing portion comprises a front hard-shell housing portion, wherein the rear housing portion comprises a rear hard-shell housing portion, wherein the front and rear hard-shell housing portions are hinged together to provide a hard-shell housing assembly, and wherein the telescopic handle assembly and the base housing component are mounted in the rear hard-shell housing portion.

11. The luggage system of claim 10, wherein the front and rear hard-shell housing portions are sealed using a two-part zipper subsystem.

12. The luggage system of claim 7, further comprises: a set of top and side handles for carrying the luggage system in one of two possible configurations comprising an upright carrying configuration, and a side carrying configuration.

13. The luggage system of claim 1 or 2 wherein the power port cover panel comprises a rubber seal along its underside to seal the one or more electrical power supply ports and the power recharging port.

4. The luggage system of claim 1 or 2 wherein the power port cover panel is spring-biased to automatically pivot to the closed configuration.

15. The luggage system of claim 7 wherein the cover panel is spring-biased to automatically pivot to the closed configuration.

2021240291 01 Oct 2021

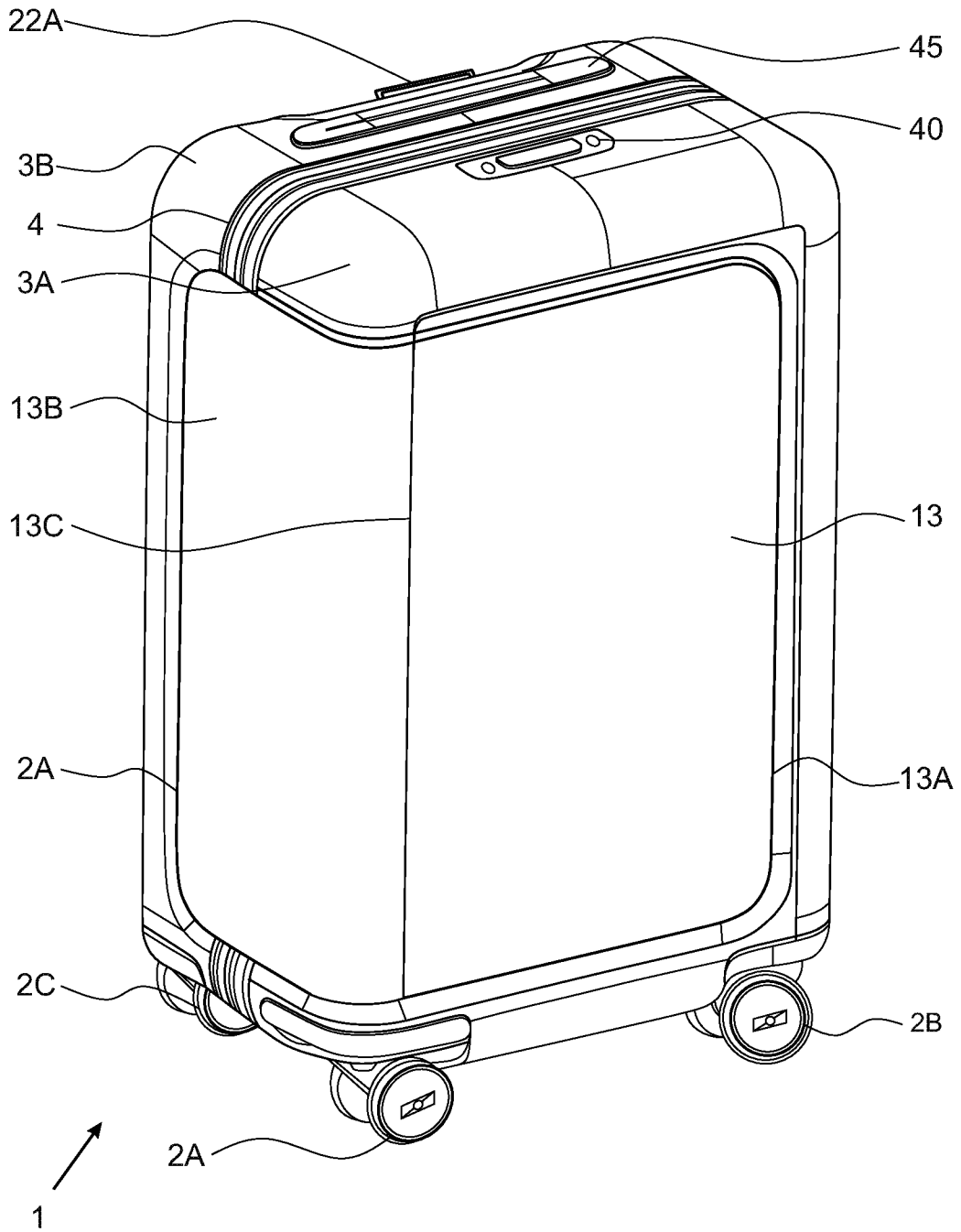

FIG. 1A

2021240291 01 Oct 2021

2/103

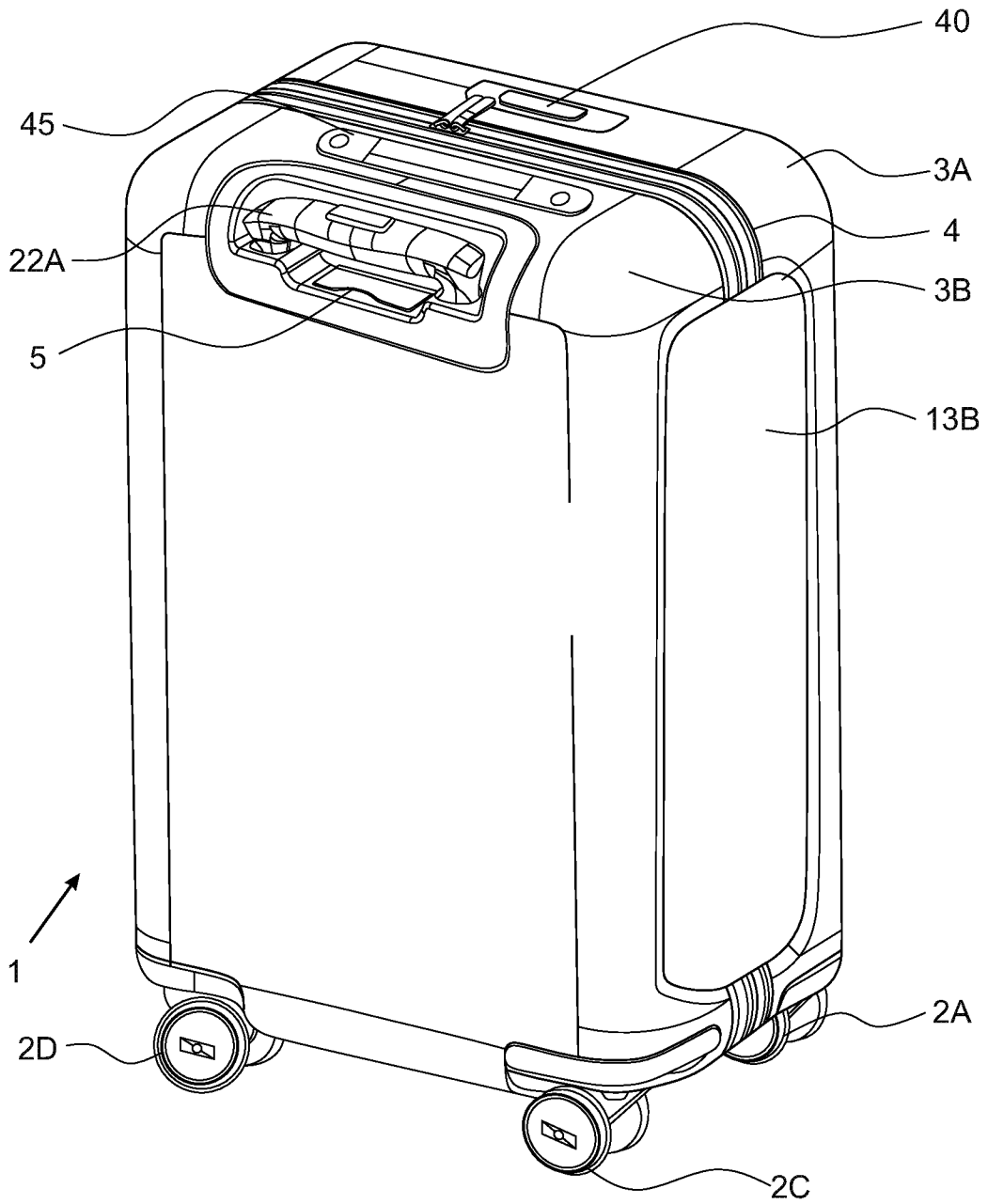

FIG. 1B

2021240291 01 Oct 2021

3/103

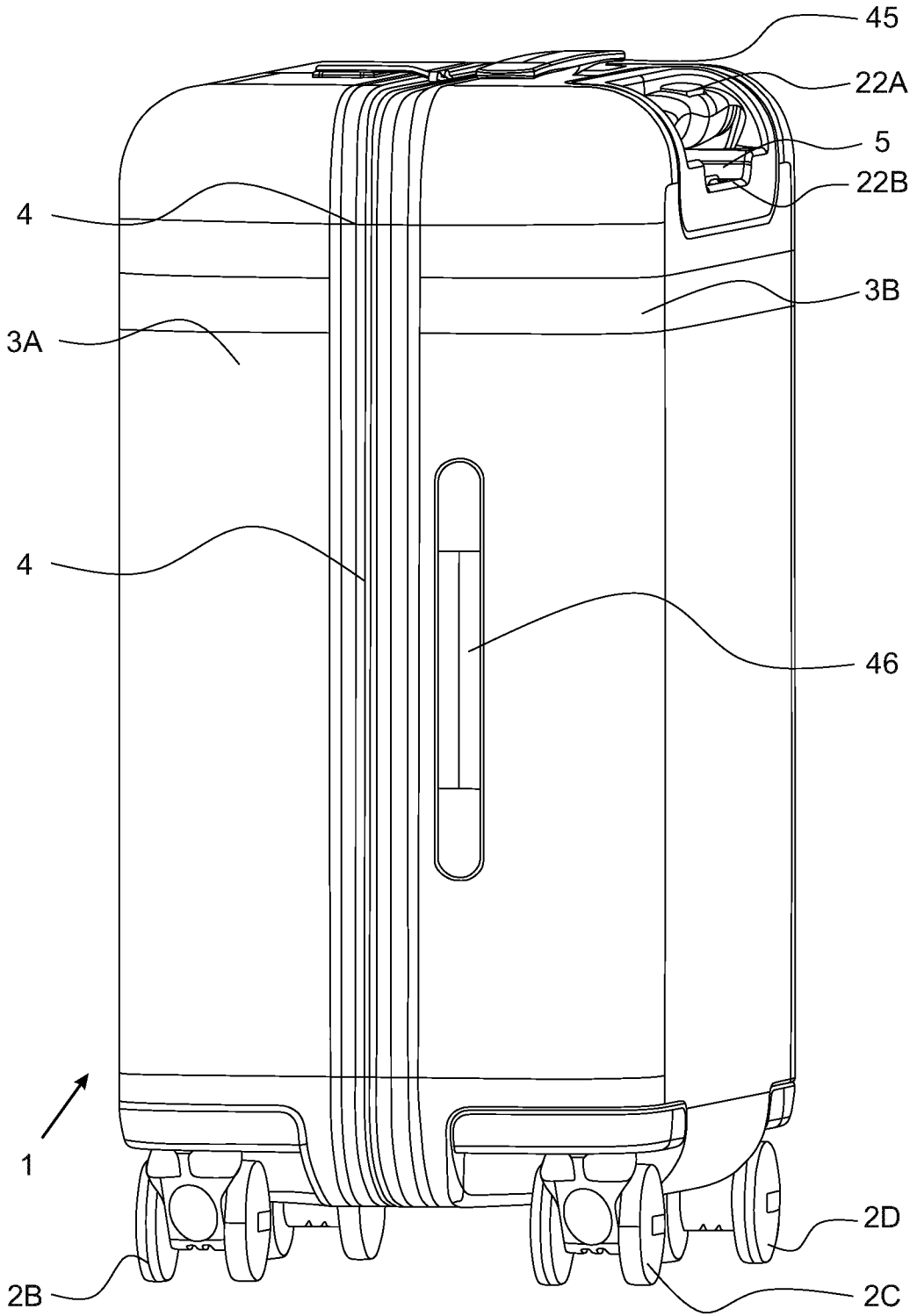

FIG. 1C

2021240291 01 Oct 2021

4/103

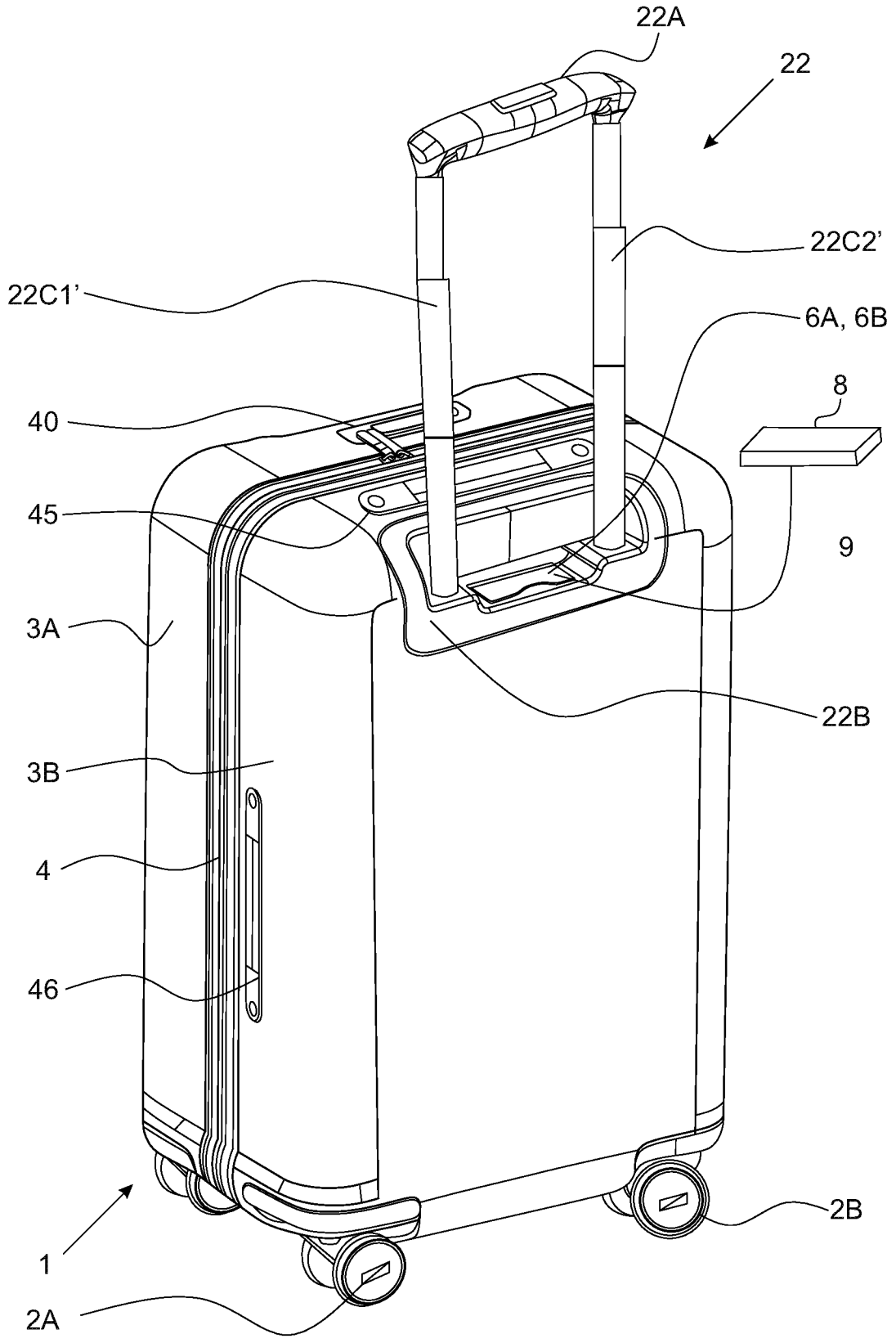

FIG. 1D

2021240291 01 Oct 2021

5/103

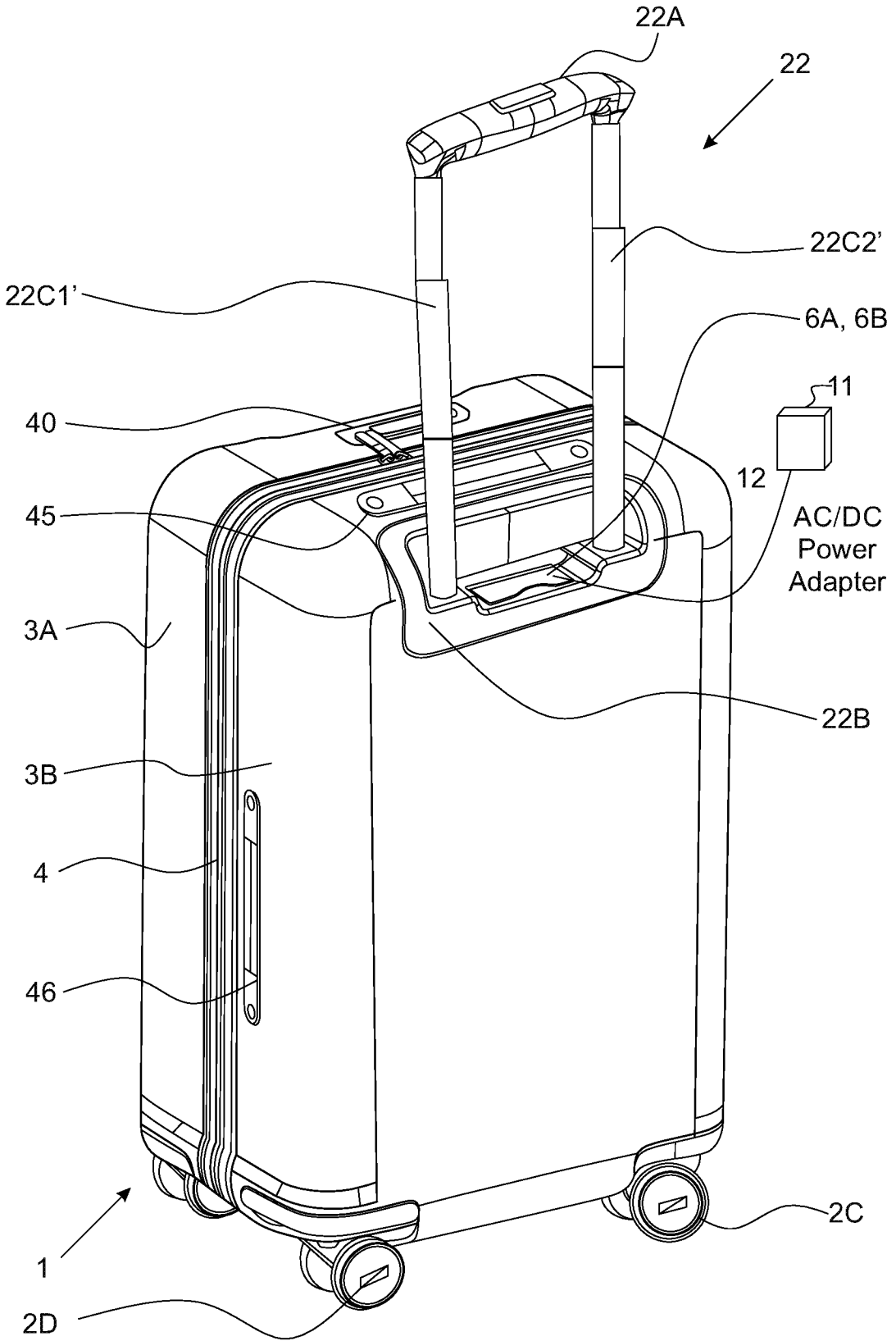
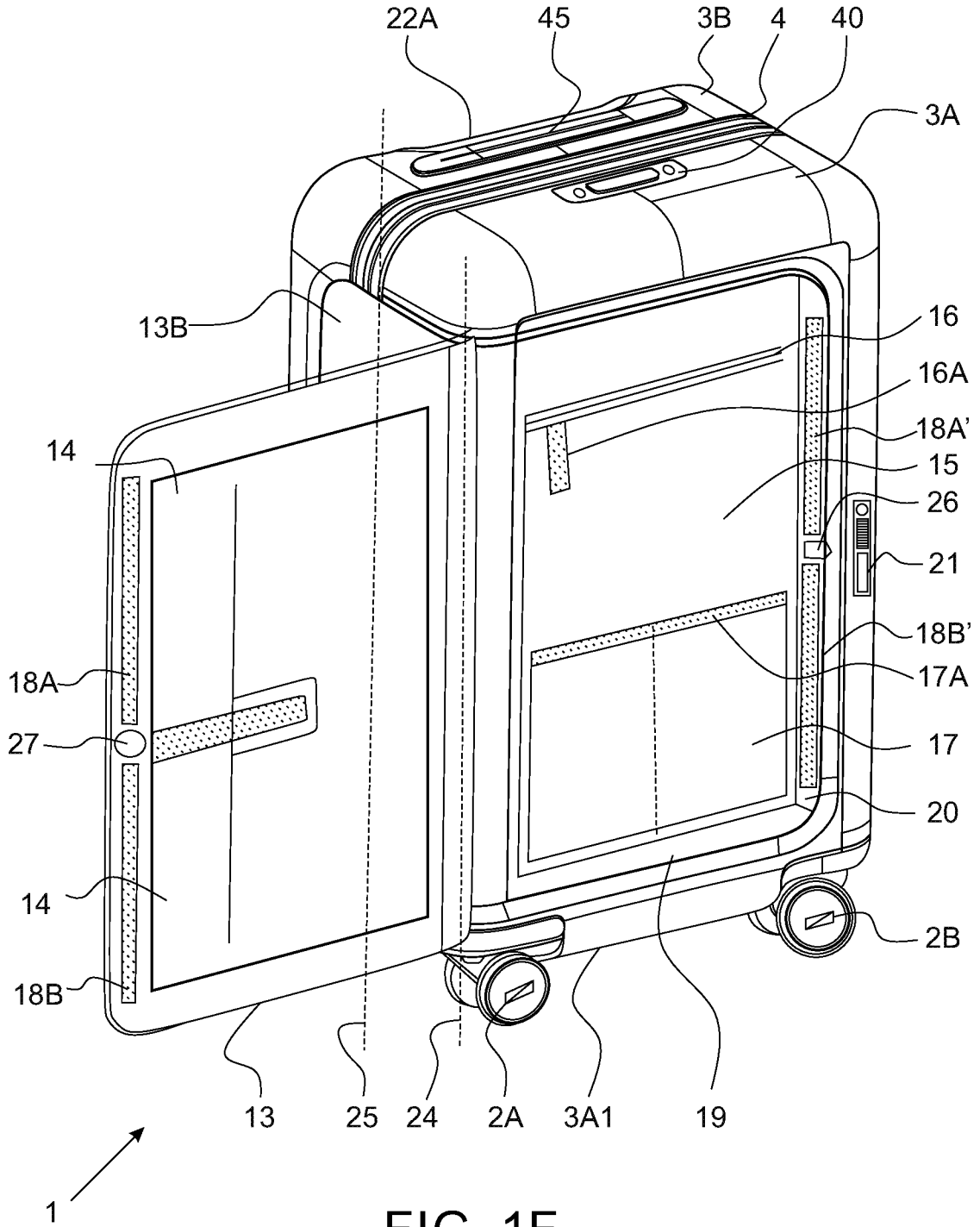

FIG. 1E



2021240291 01 Oct 2021

7/103

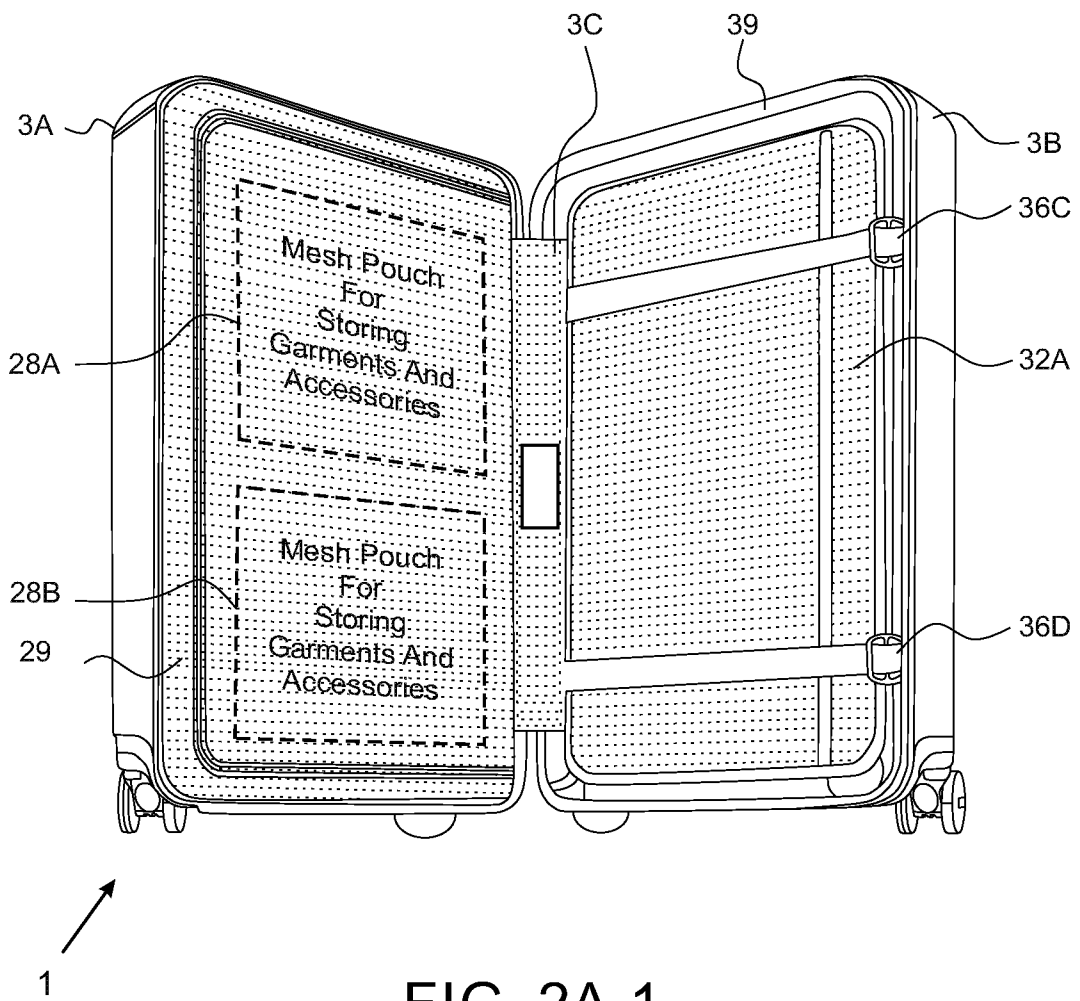

FIG. 2A-1

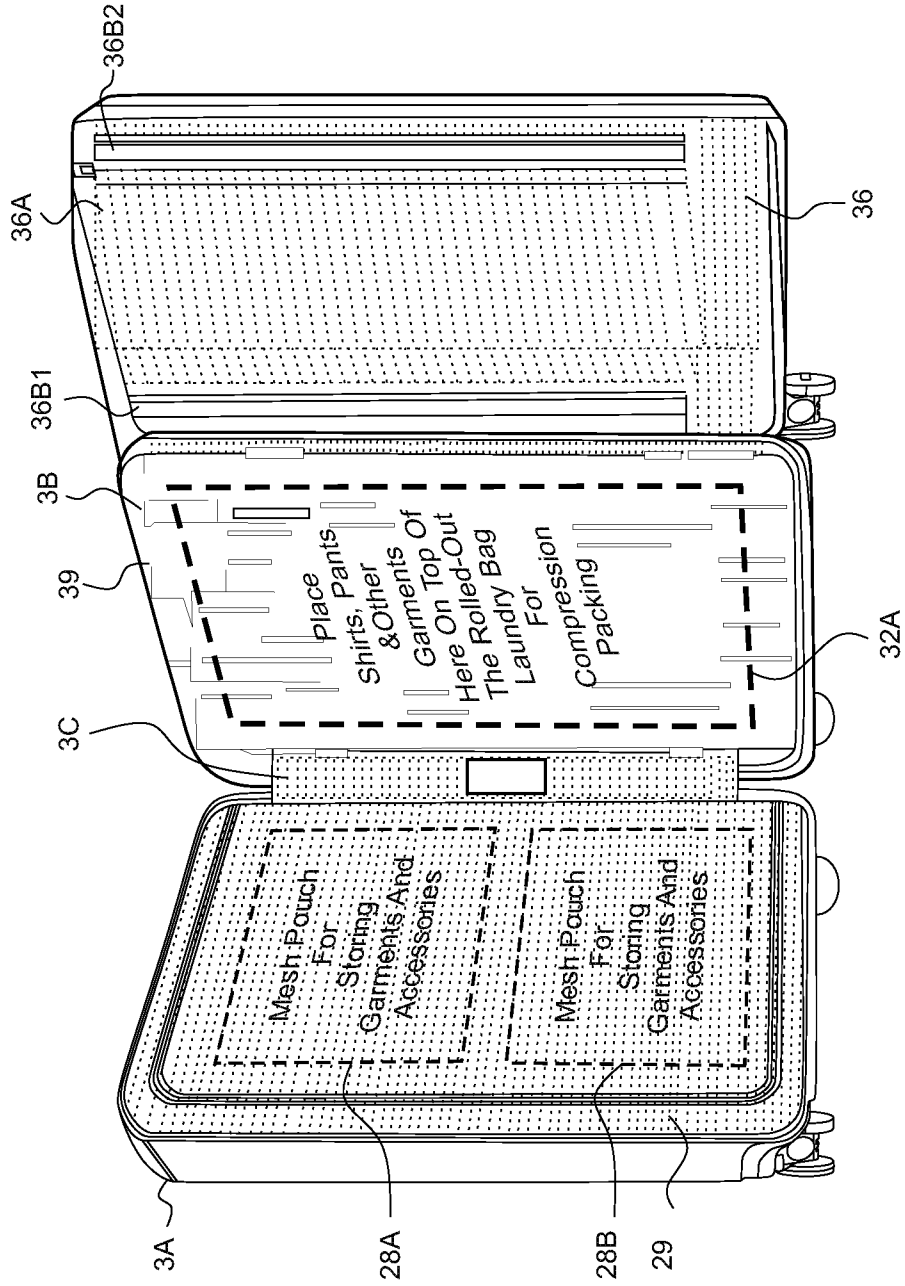

FIG. 2A-2

2021240291 01 Oct 2021

9/103

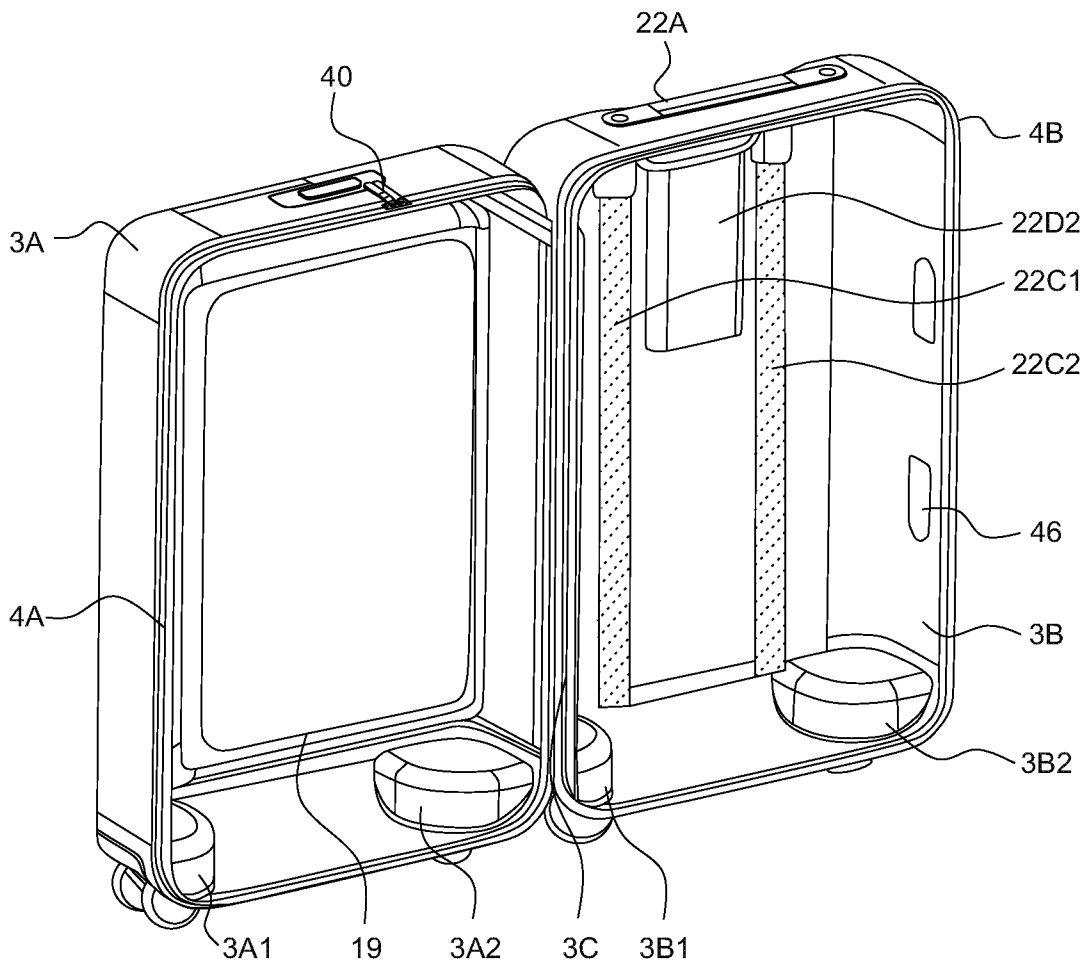

FIG. 2B

2021240291 01 Oct 2021

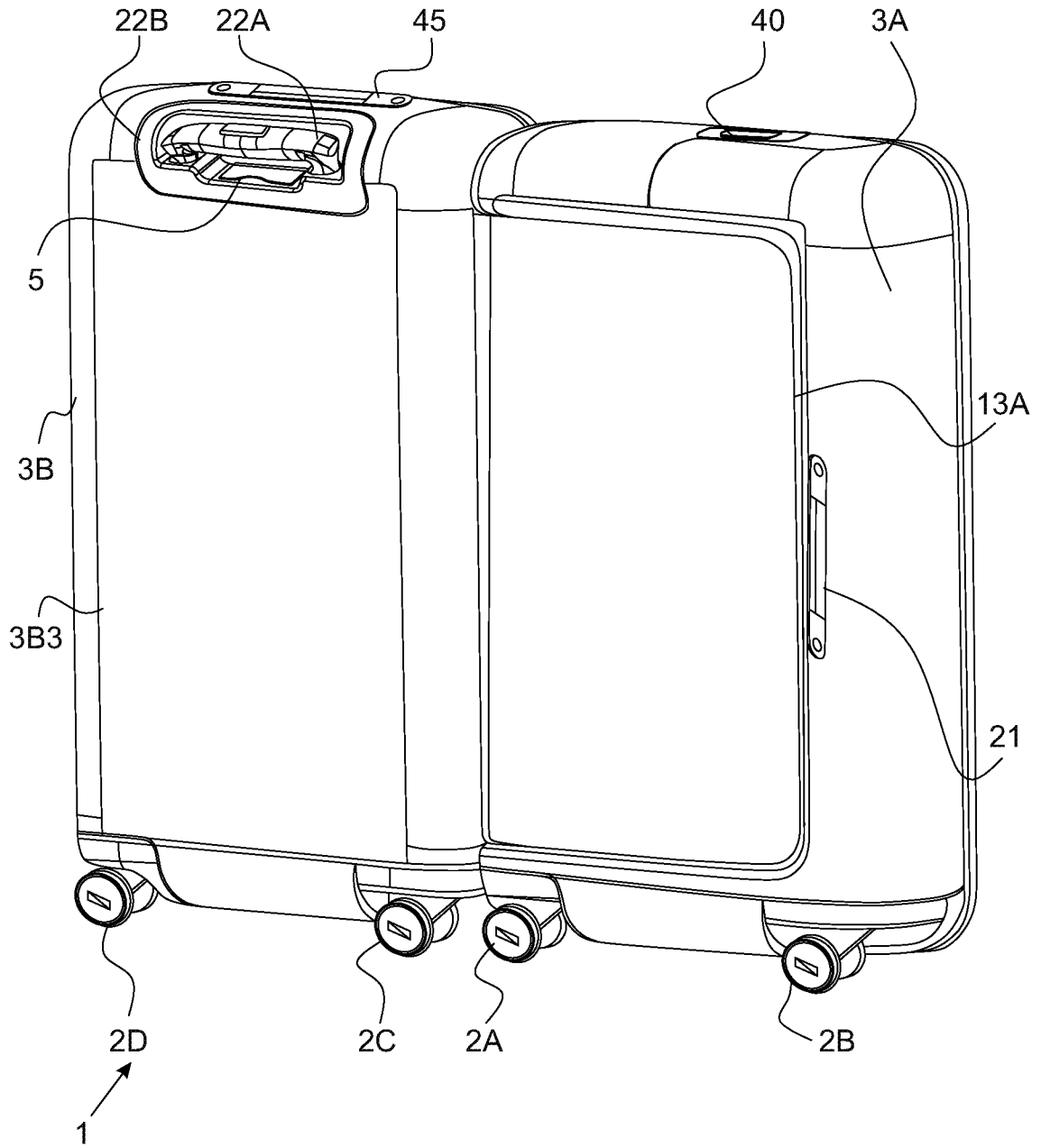

FIG. 2C

2021240291 01 Oct 2021

11/103

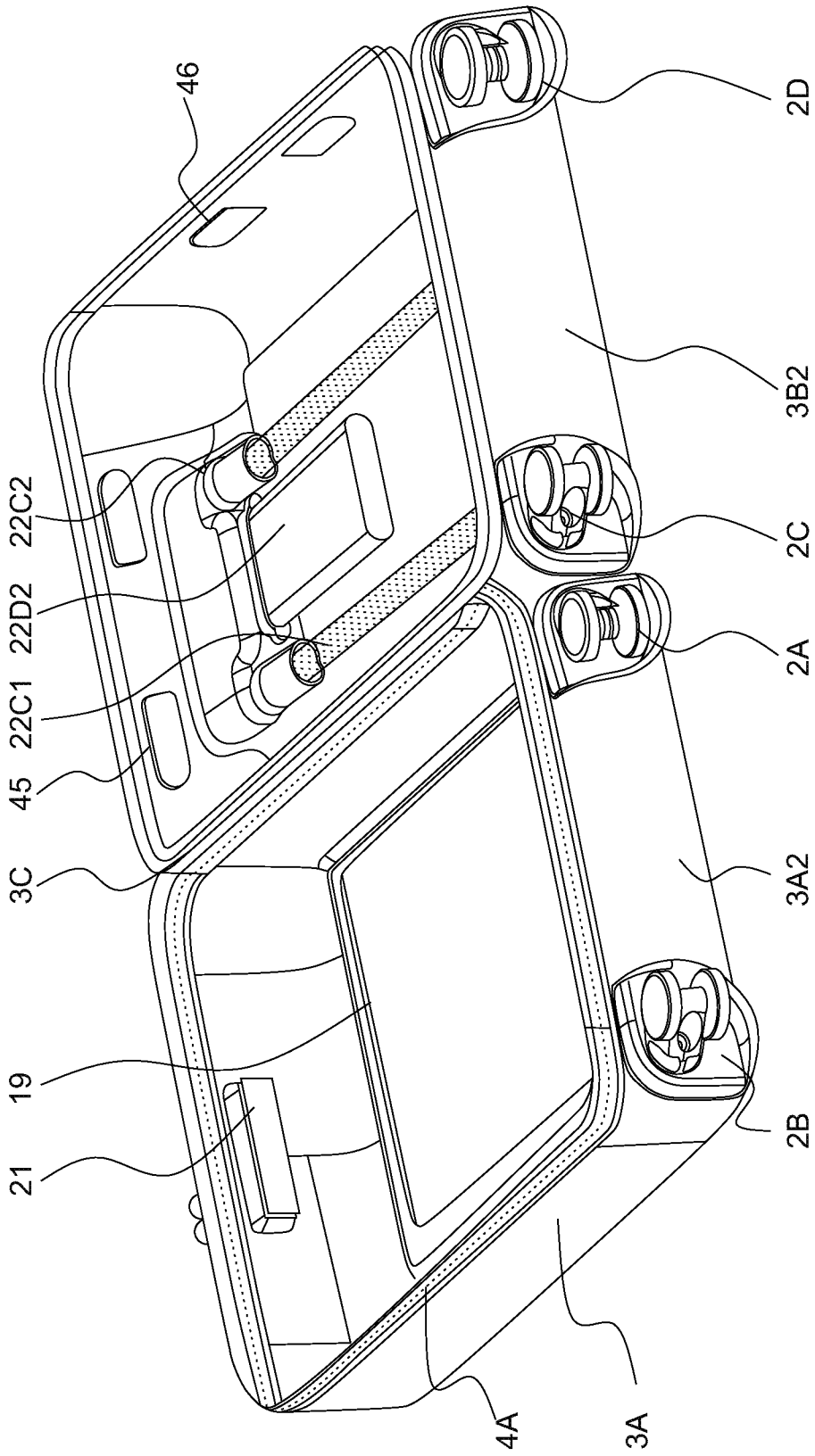

FIG. 2D

12/103

2021240291 01 Oct 2021

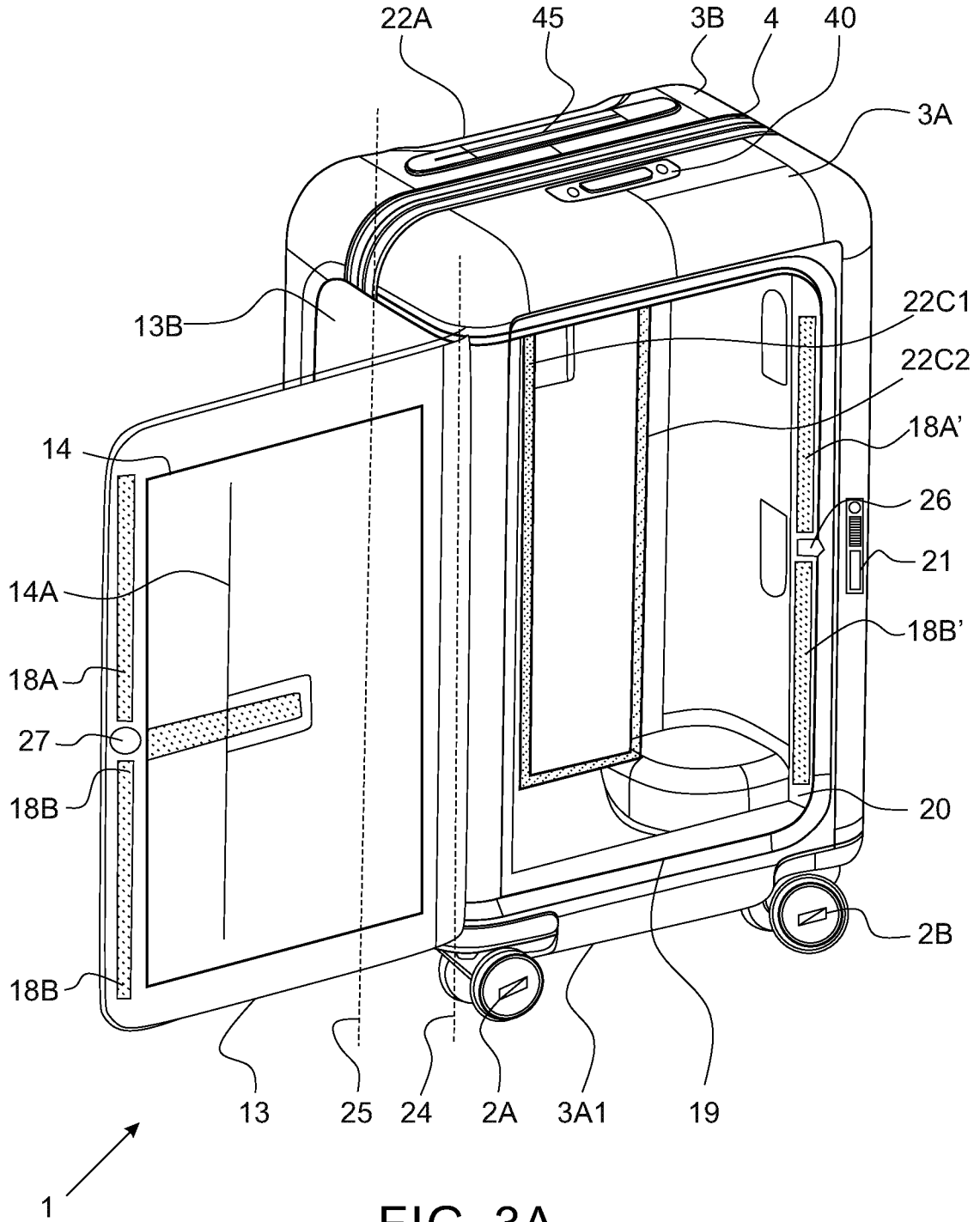

FIG. 3A

2021240291 01 Oct 2021

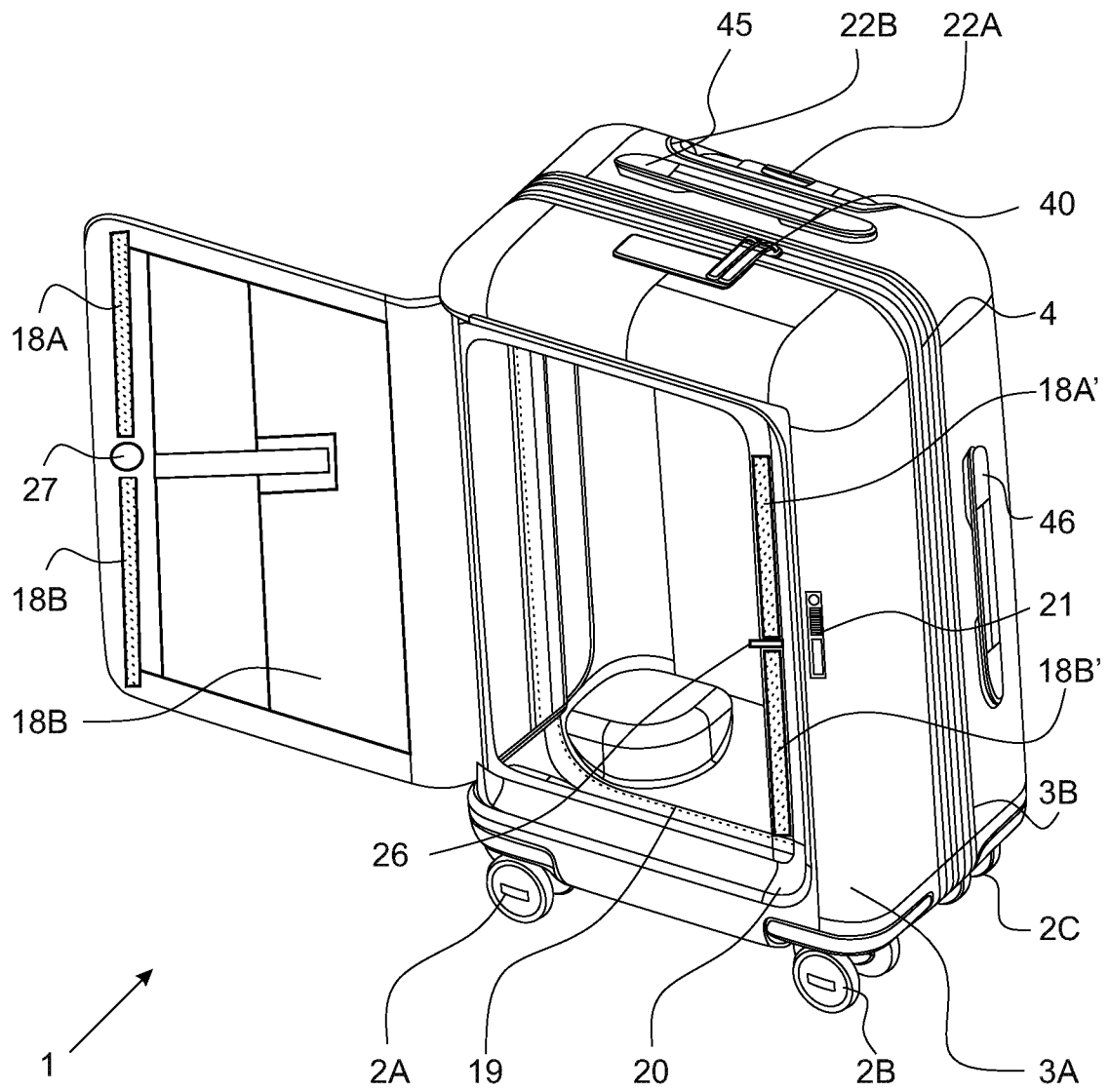

FIG. 3B

2021240291 01 Oct 2021

14/103

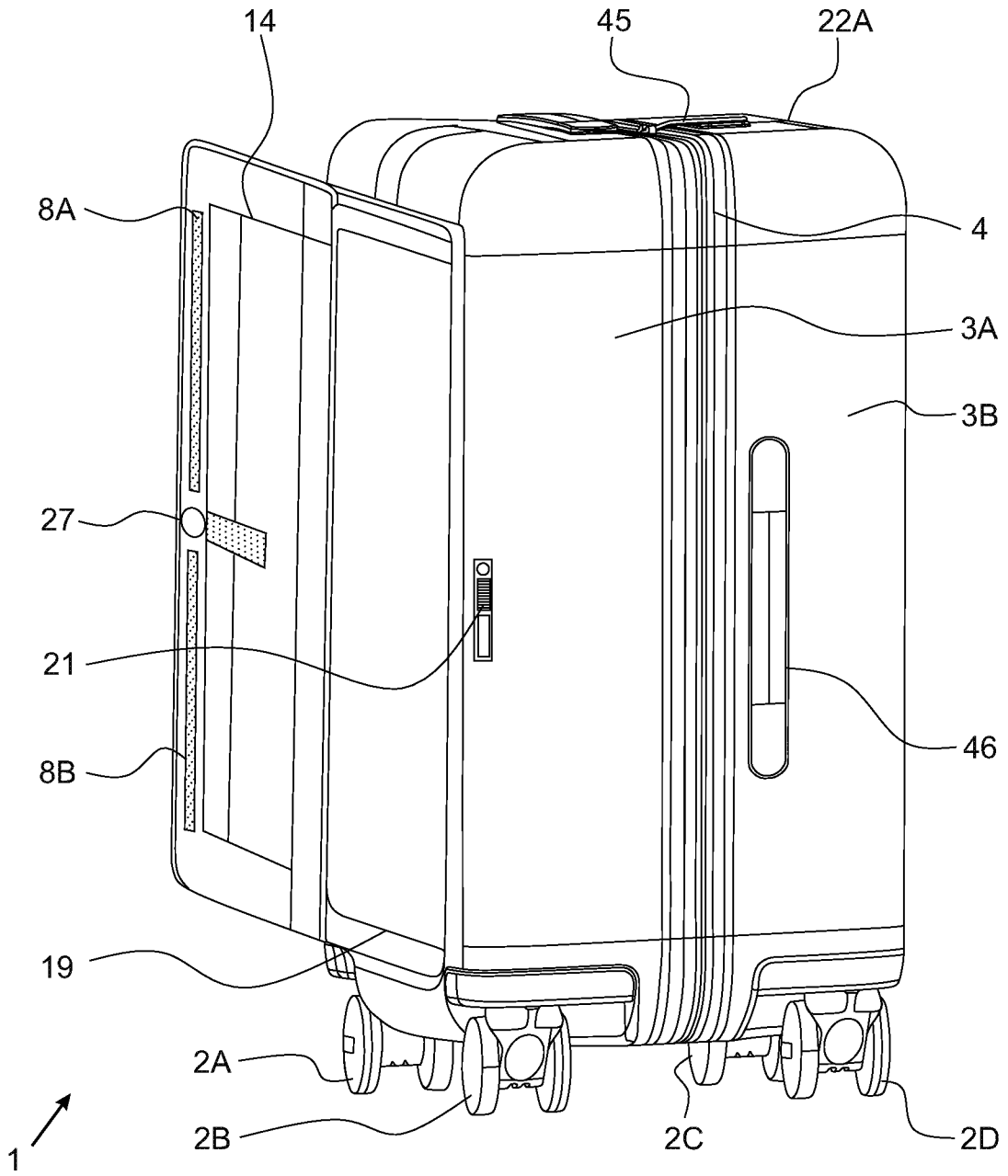

FIG. 3C

2021240291 01 Oct 2021

15/103

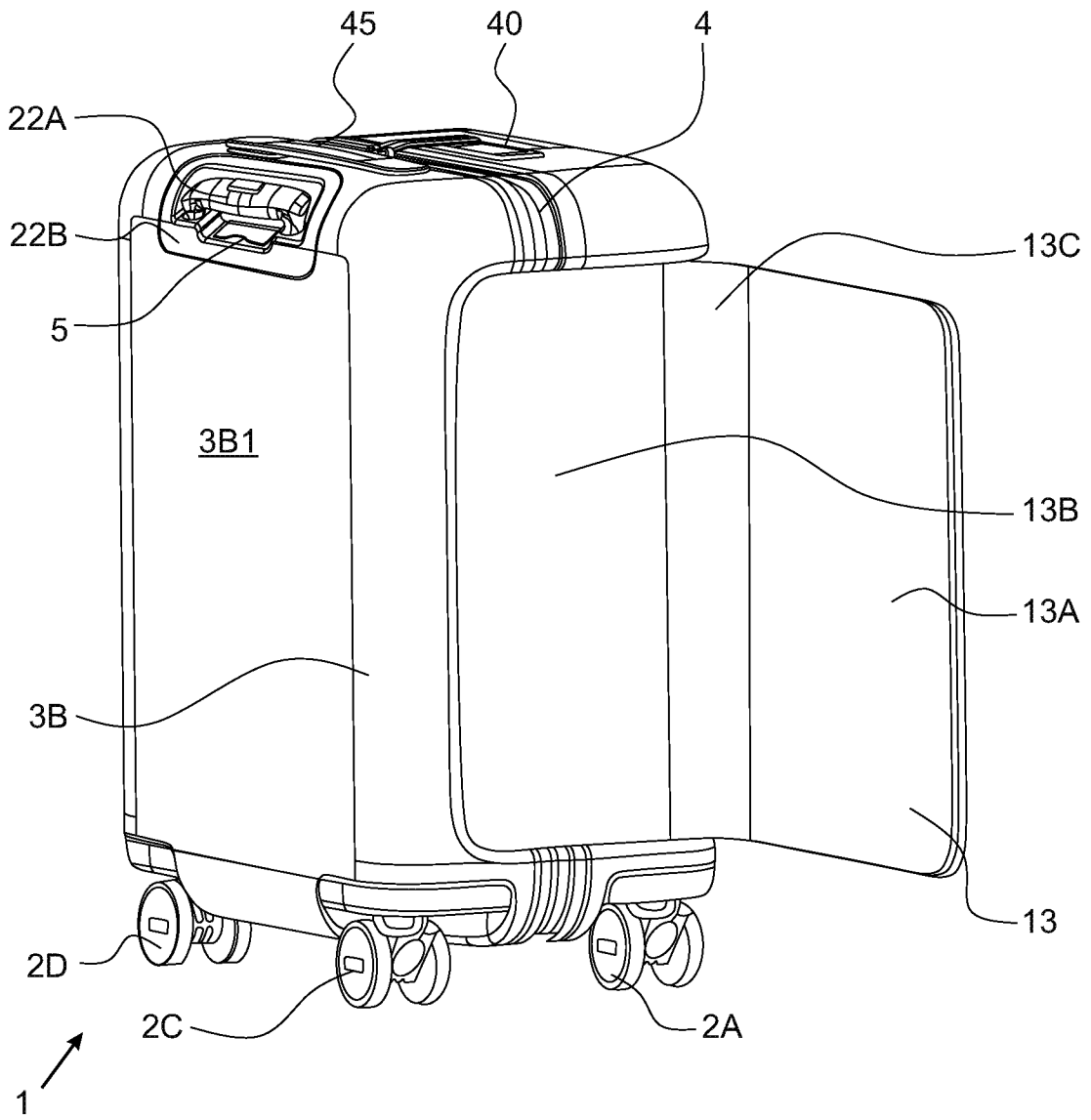

FIG. 3D

2021240291 01 Oct 2021

16/103

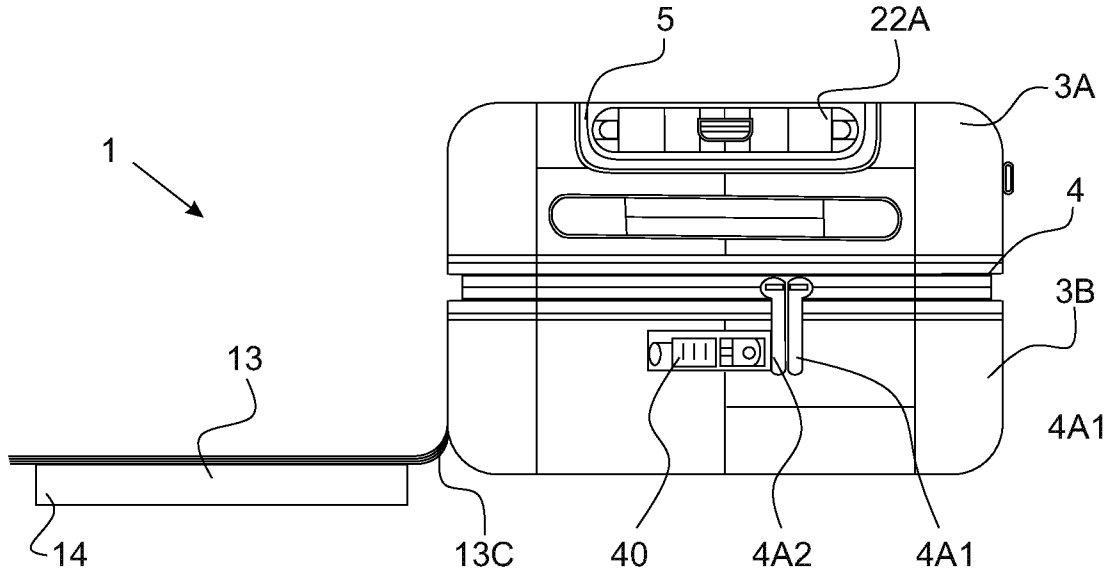

FIG. 3E

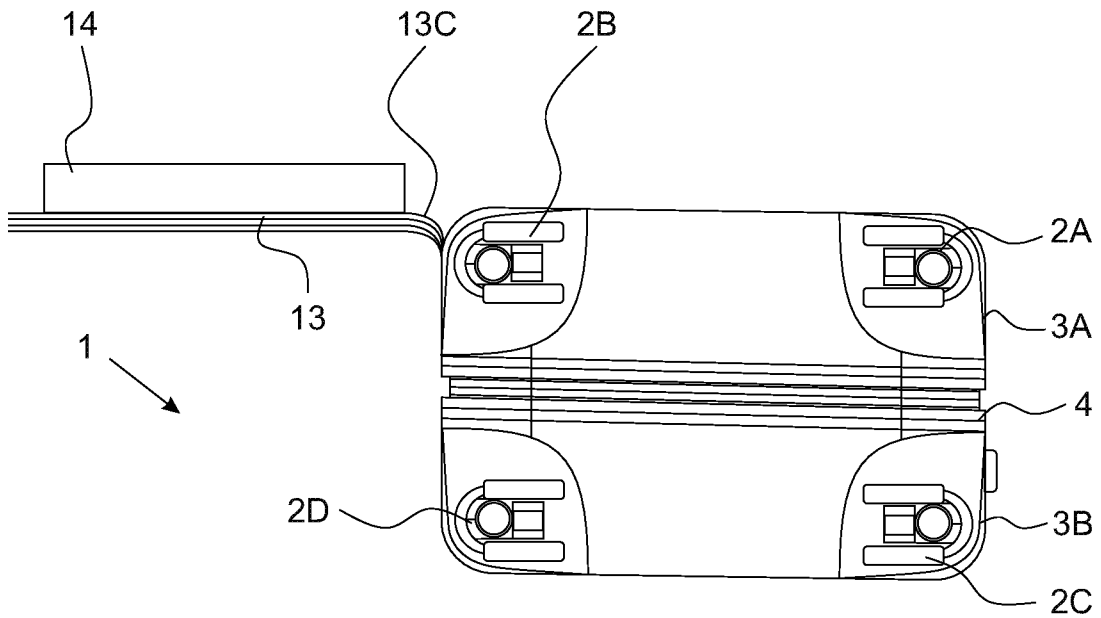

FIG. 3F

2021240291 01 Oct 2021

17/103

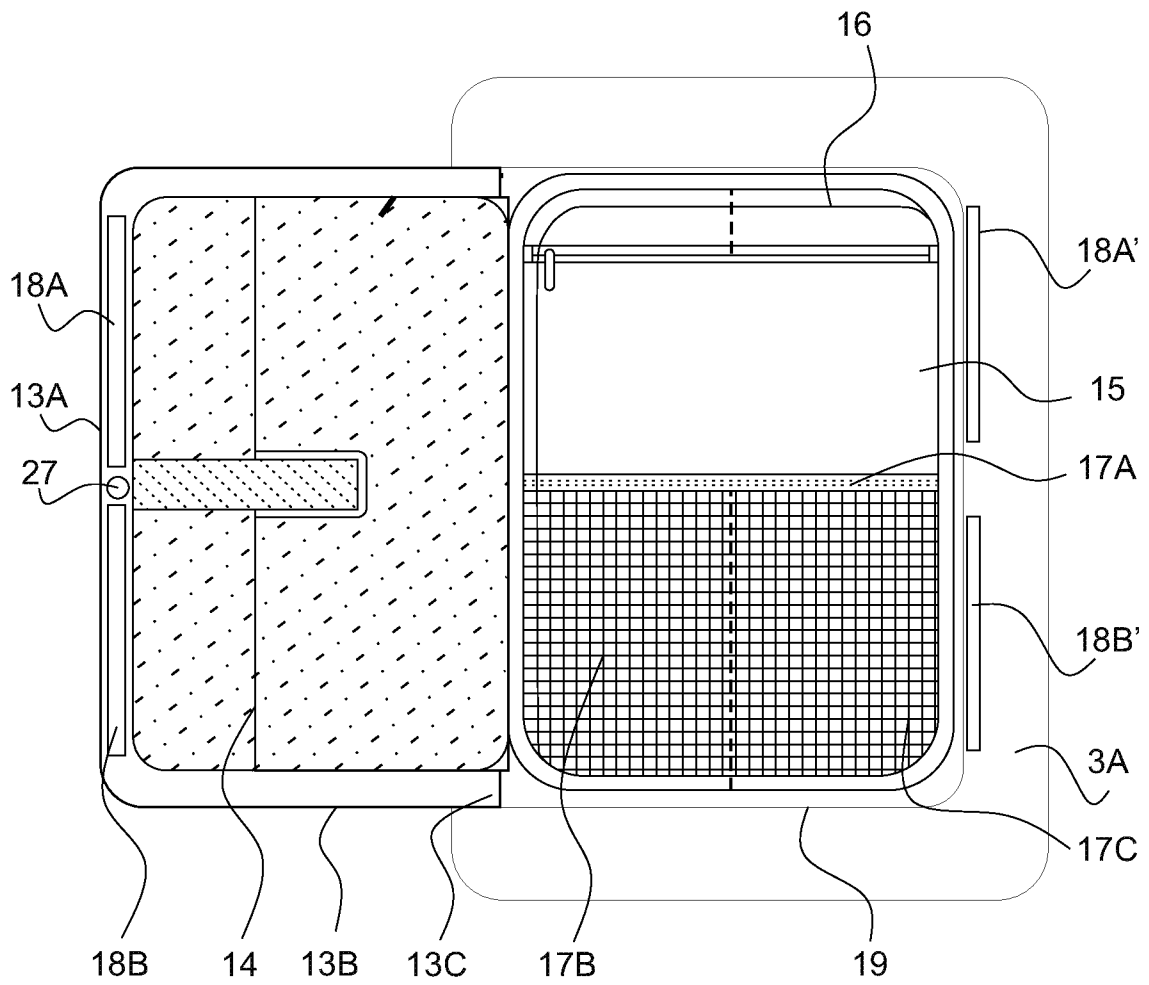

FIG. 4A

2021240291 01 Oct 2021

18/103

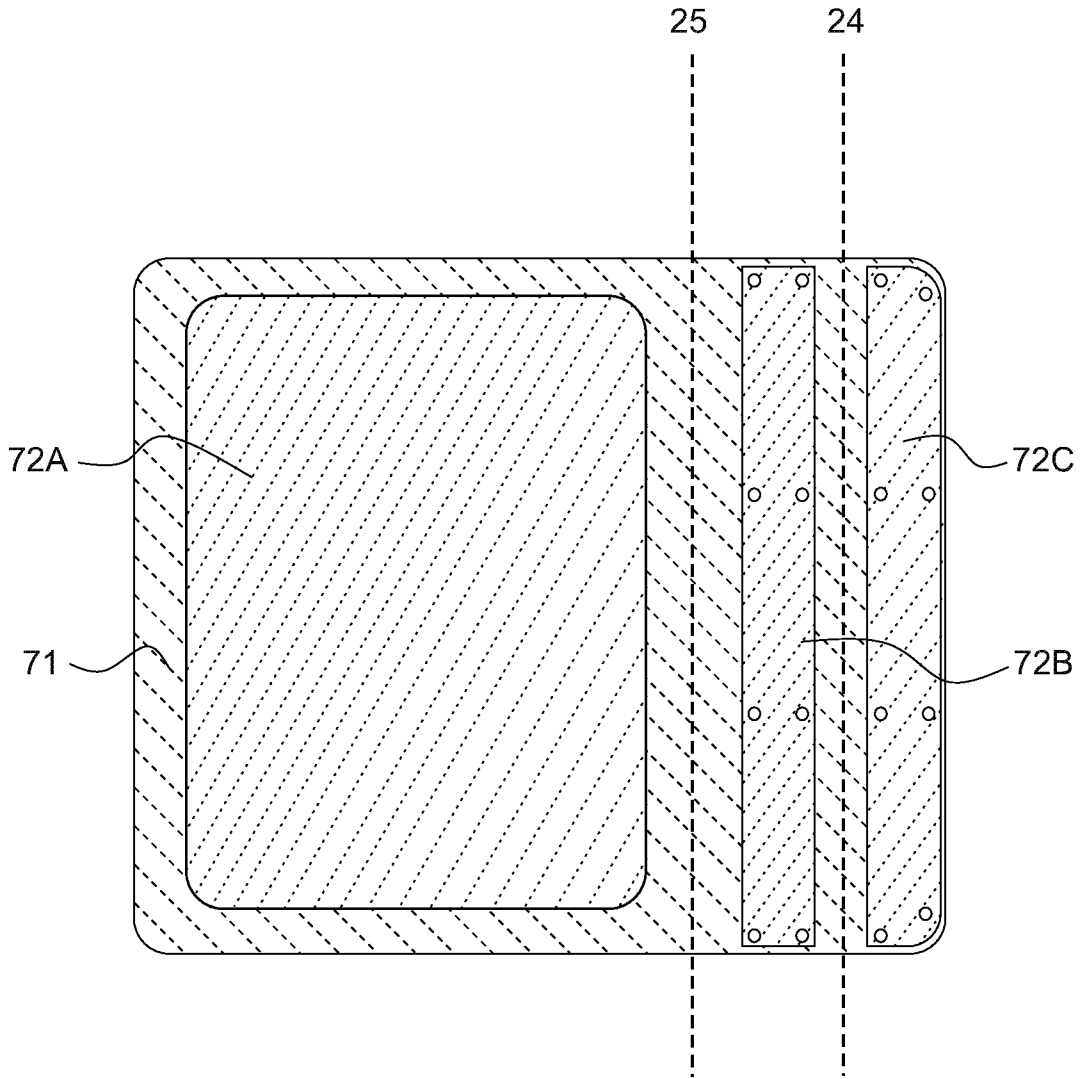

FIG. 4B

2021240291 01 Oct 2021

19/103

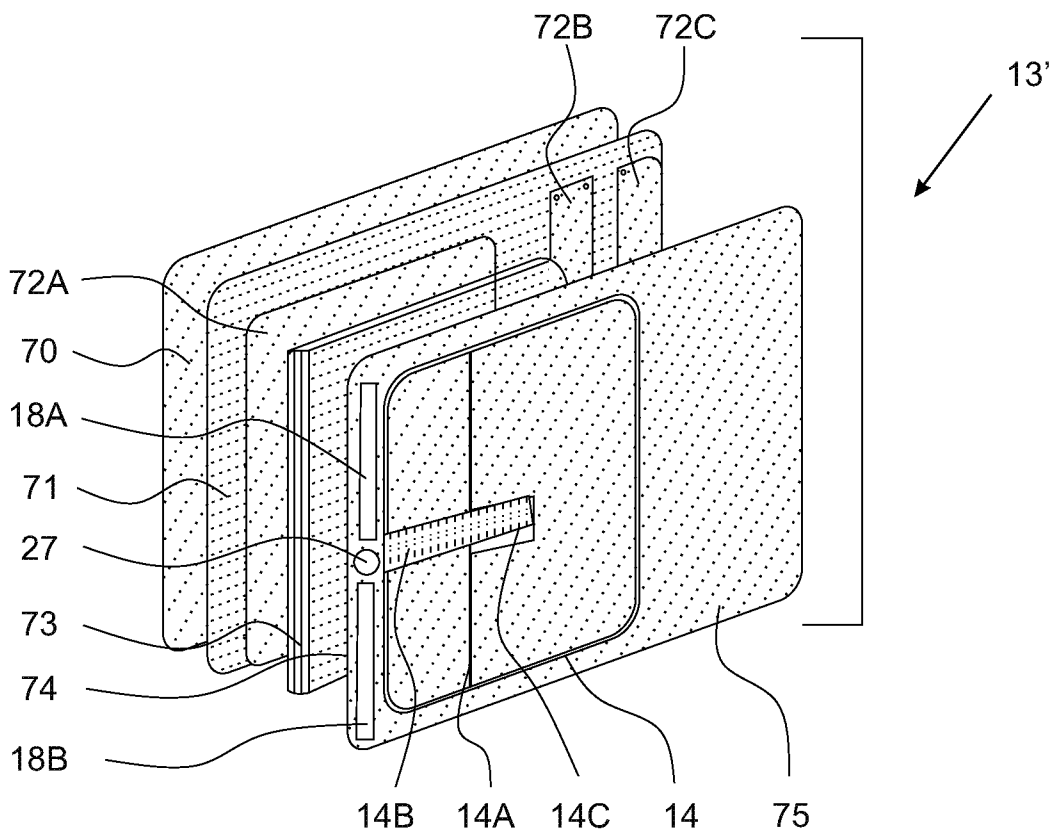

FIG. 4C

2021240291 01 Oct 2021

20/103

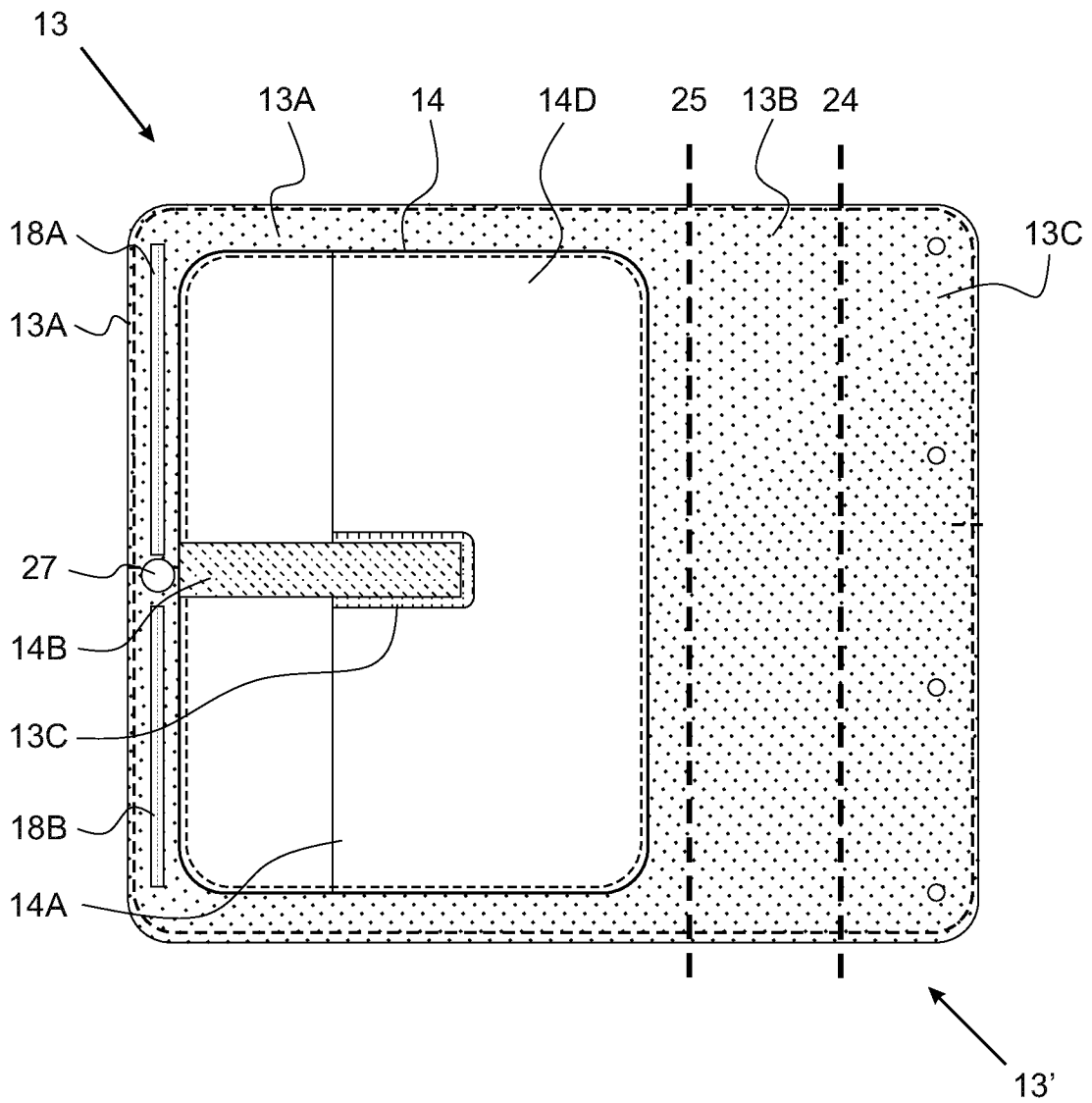

FIG. 4D

2021240291 01 Oct 2021

21/103

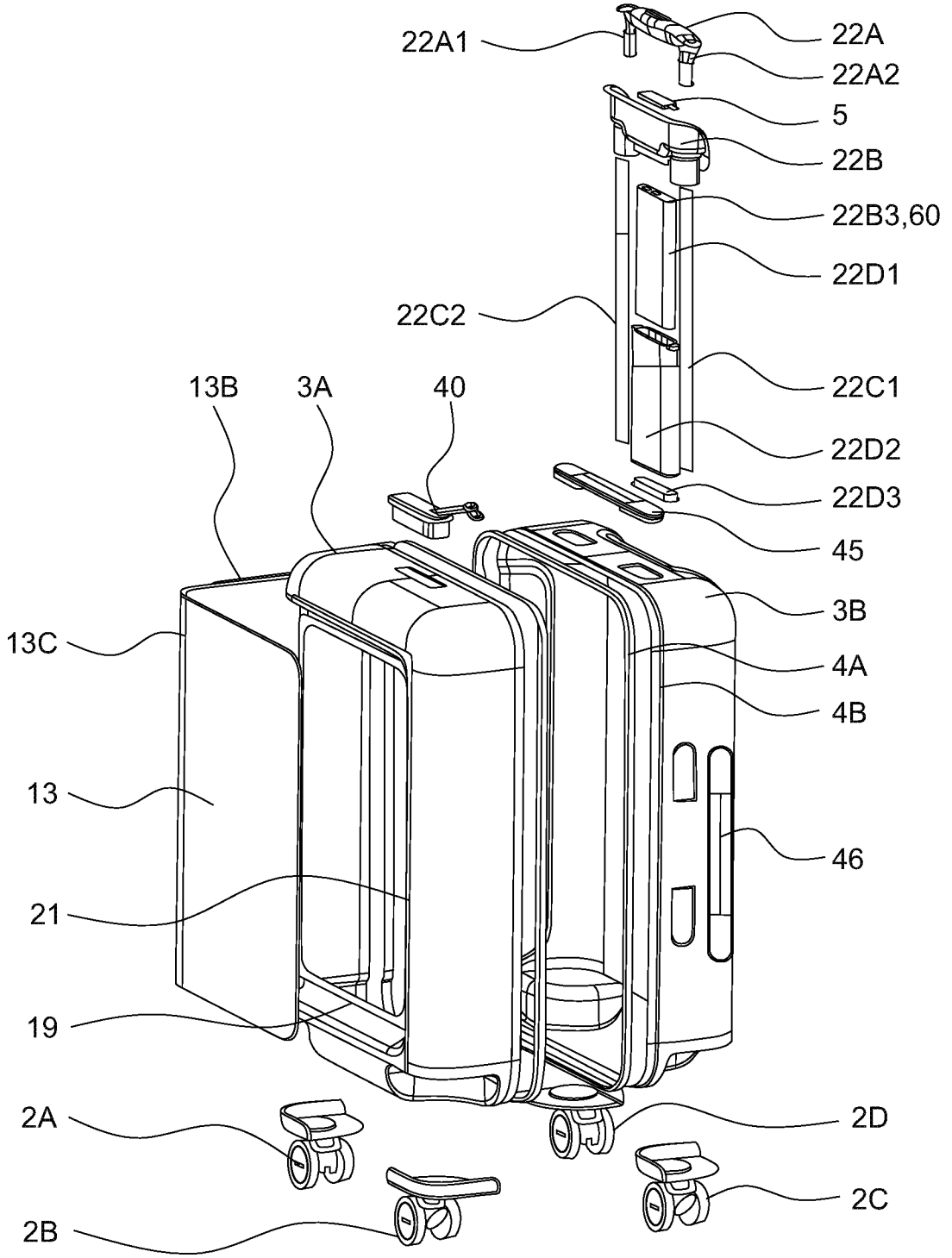

FIG.5A



2021240291 01 Oct 2021

22/103

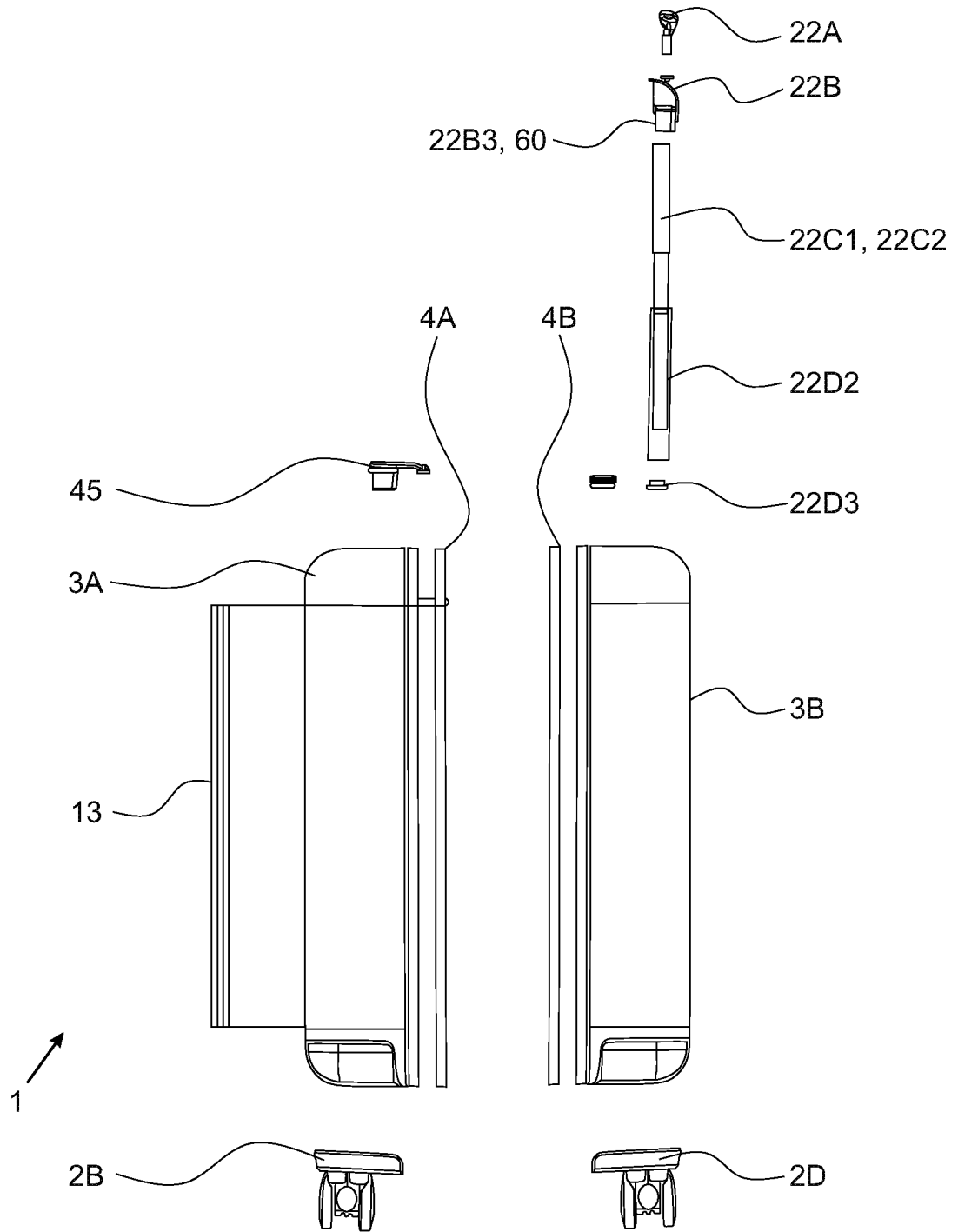

FIG. 5B

2021240291 01 Oct 2021

23/103

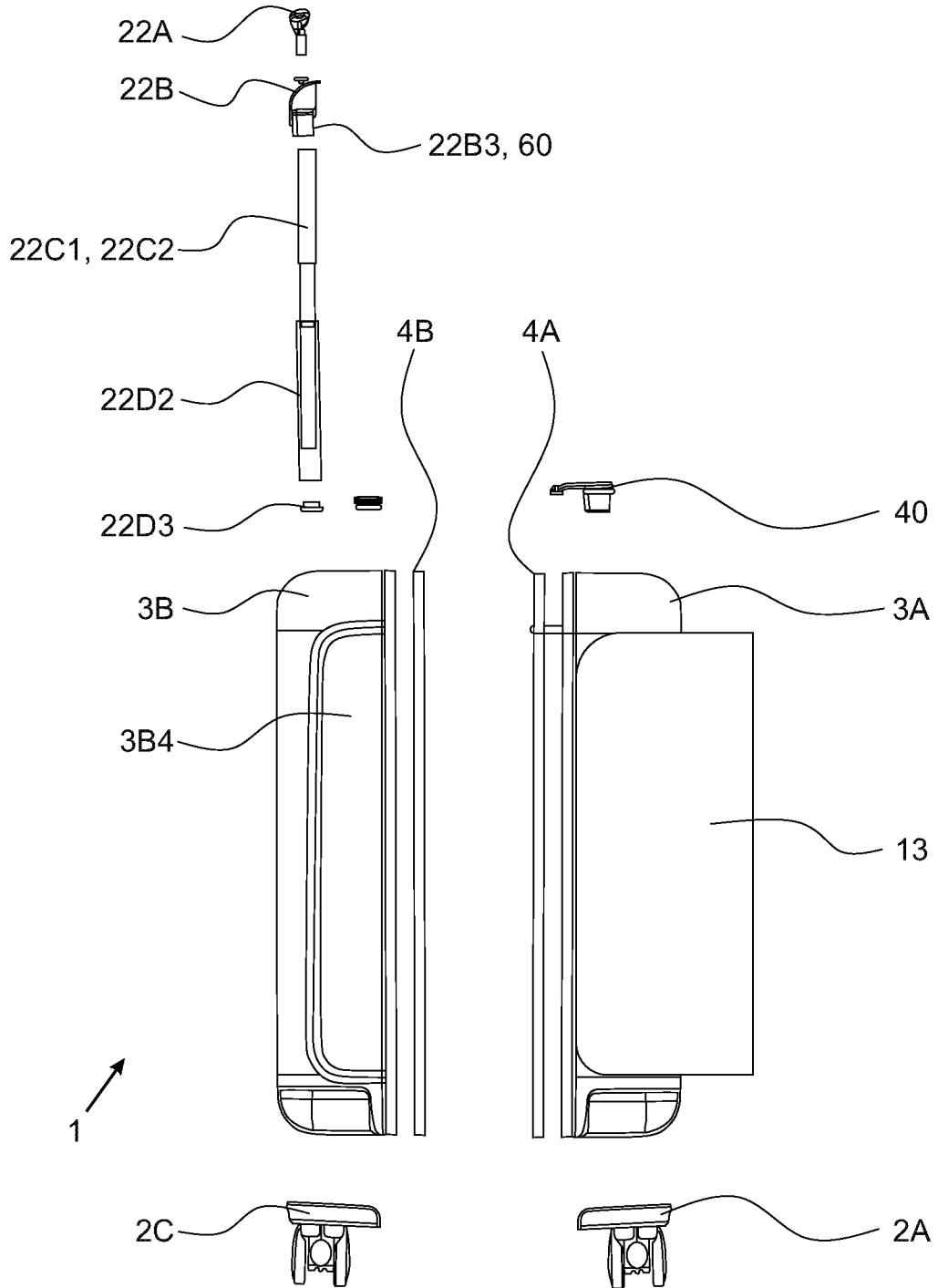

FIG. 5C

2021240291 01 Oct 2021

24/103

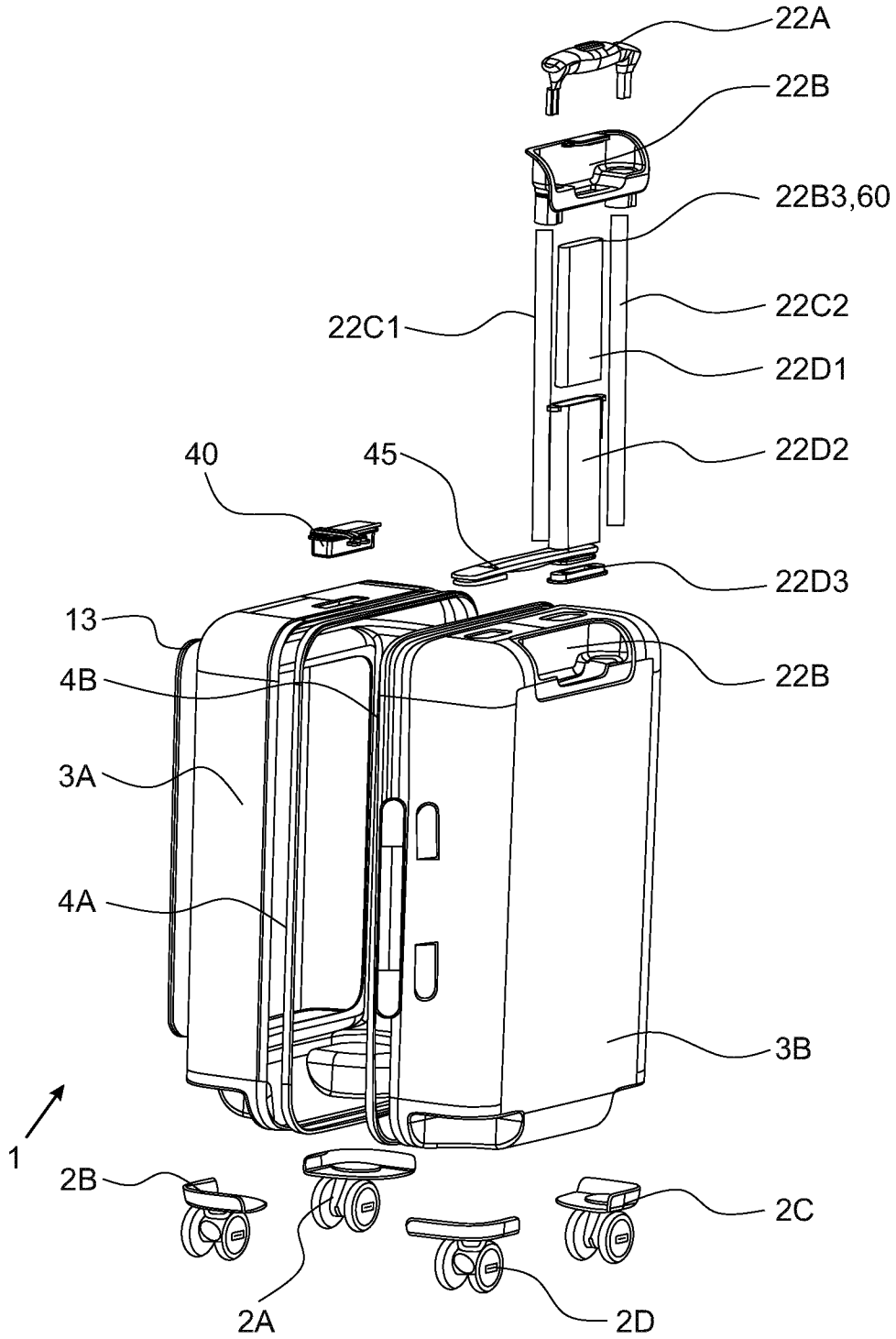

FIG. 5D

2021240291 01 Oct 2021

25/103

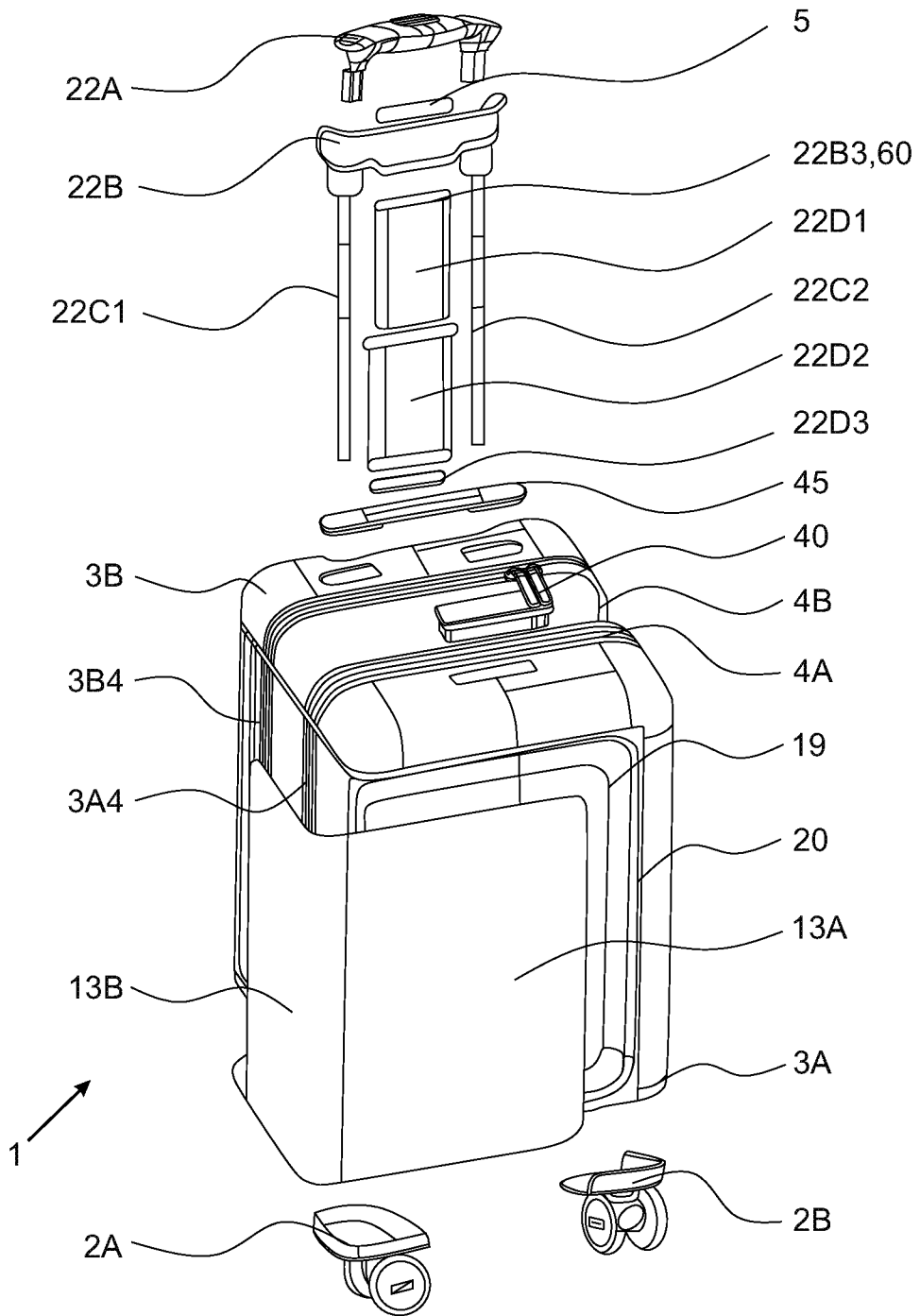

FIG. 5E

2021240291 01 Oct 2021

26/103

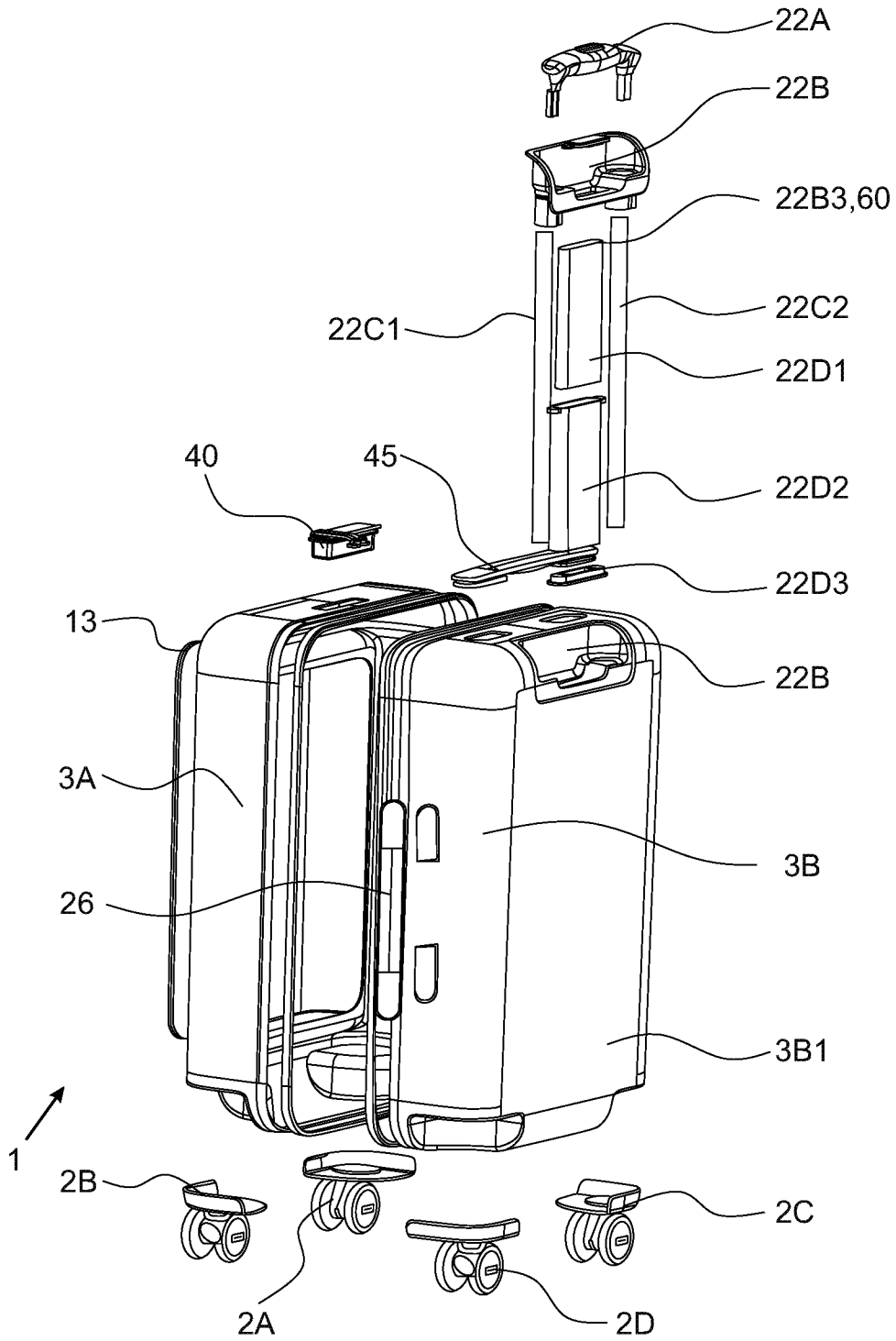

FIG. 5F

2021240291 01 Oct 2021

27/103

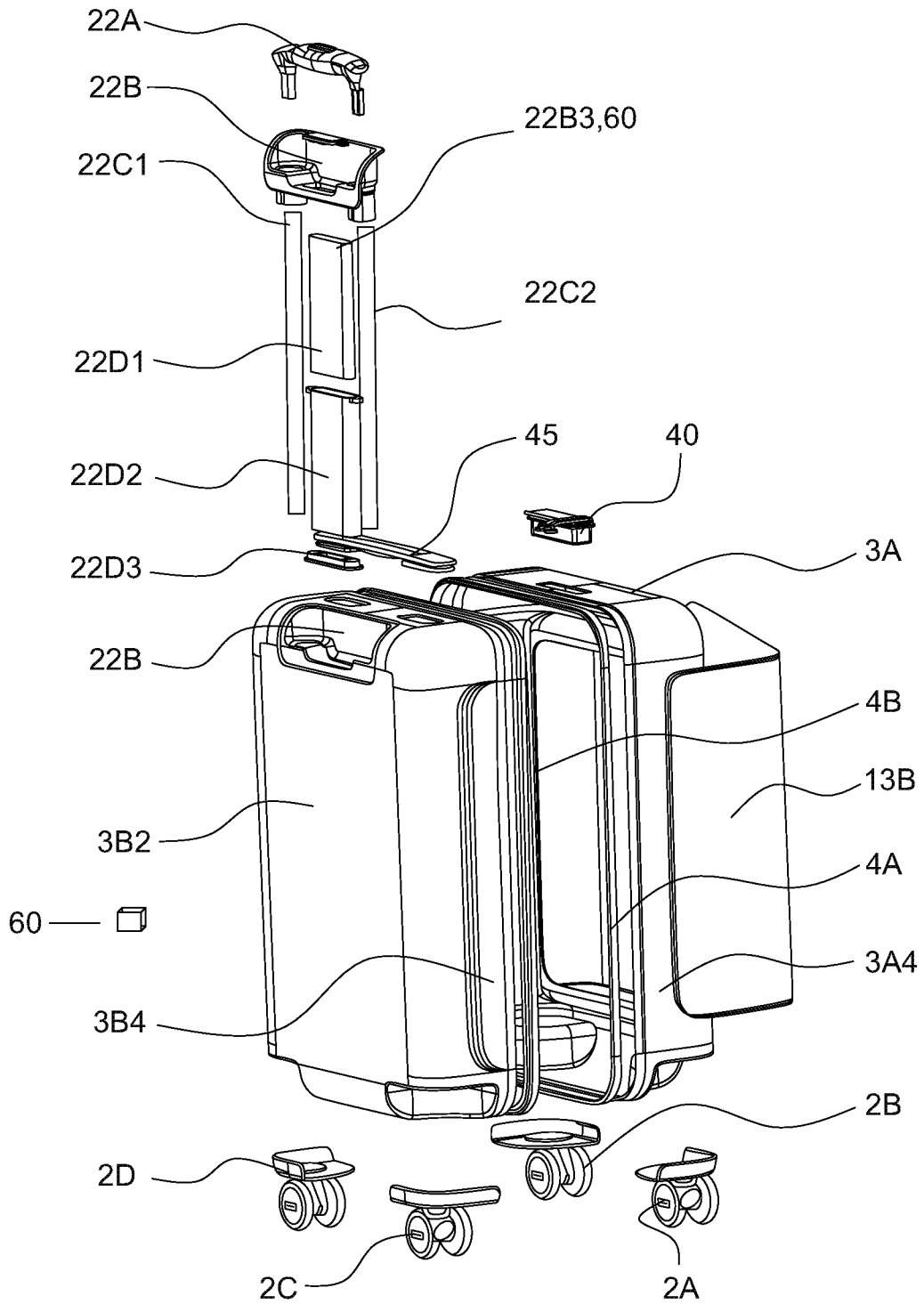

FIG. 5G

2021240291 01 Oct 2021

28/103

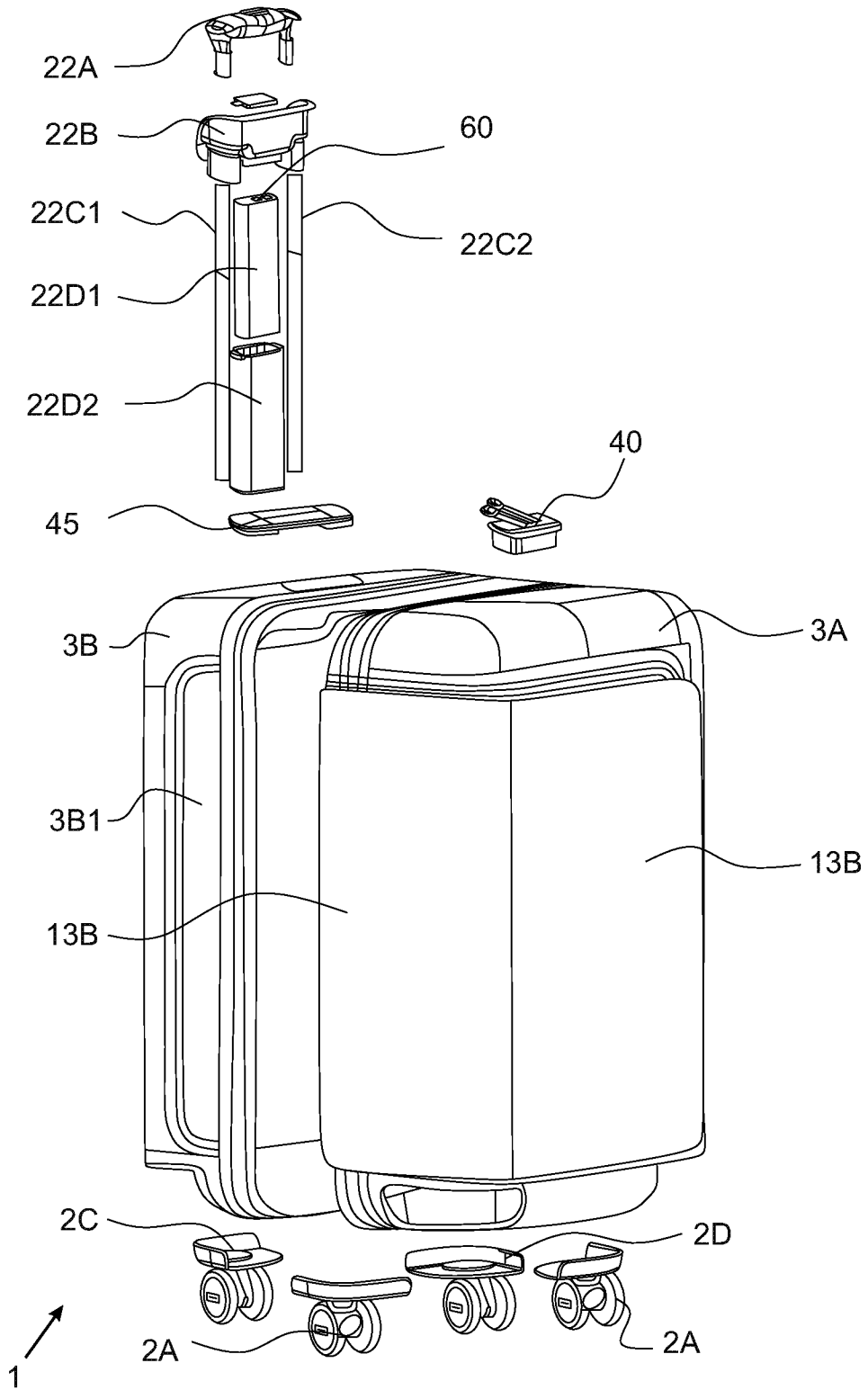

FIG. 5H

2021240291 01 Oct 2021

29/103

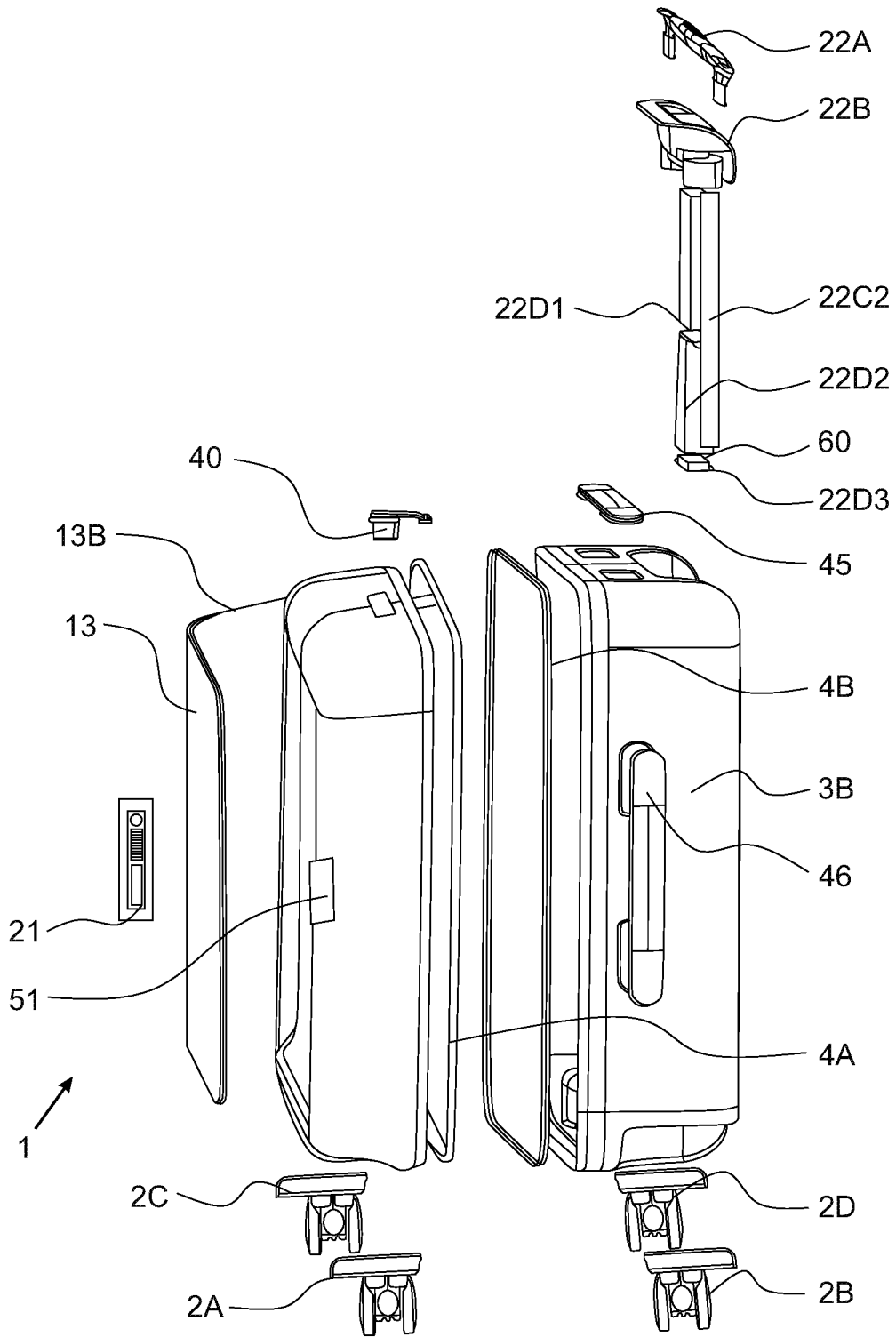

FIG. 5I

2021240291 01 Oct 2021

30/103

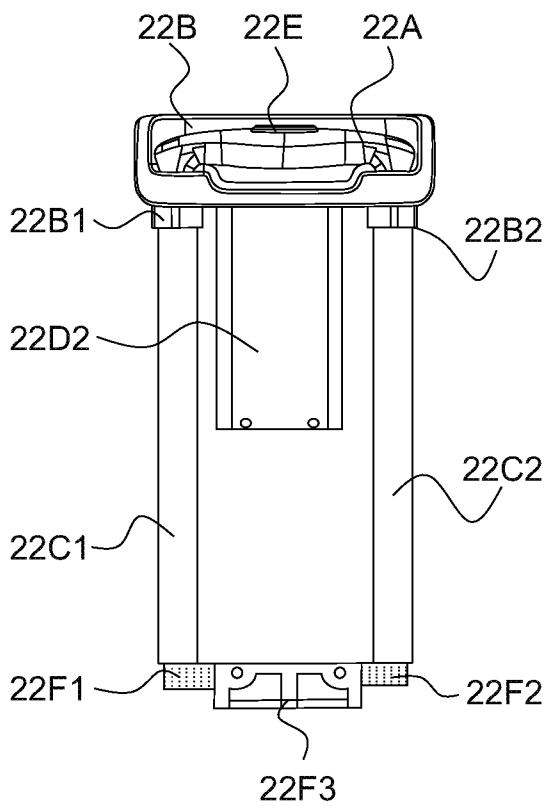

FIG. 5J1

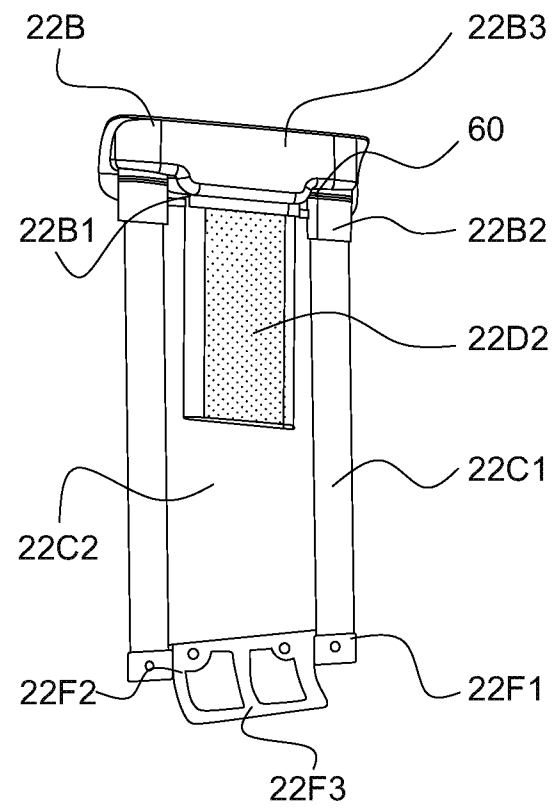

FIG. 5J2

2021240291 01 Oct 2021

31/103

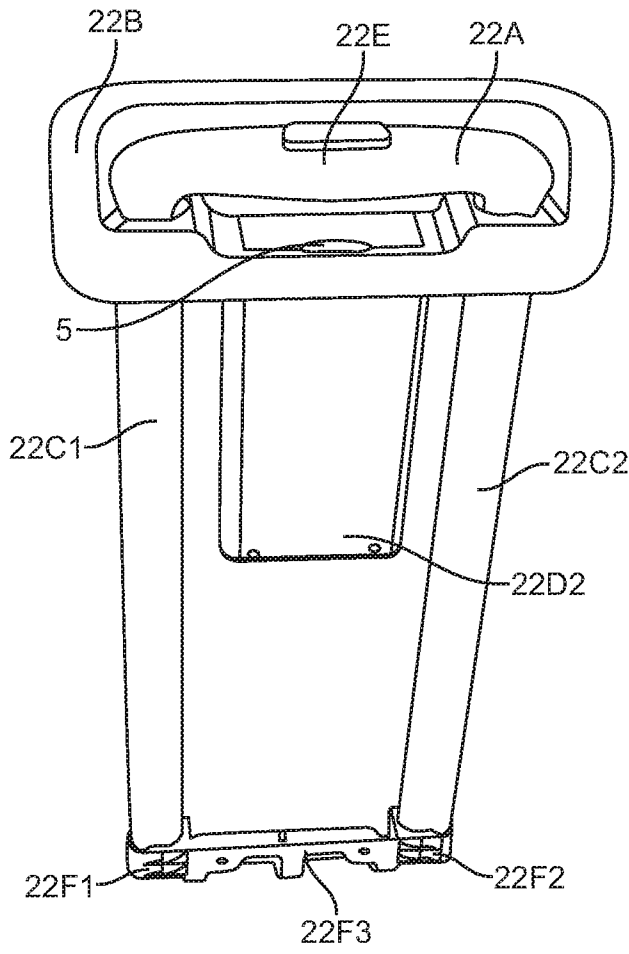

FIG. 5J3

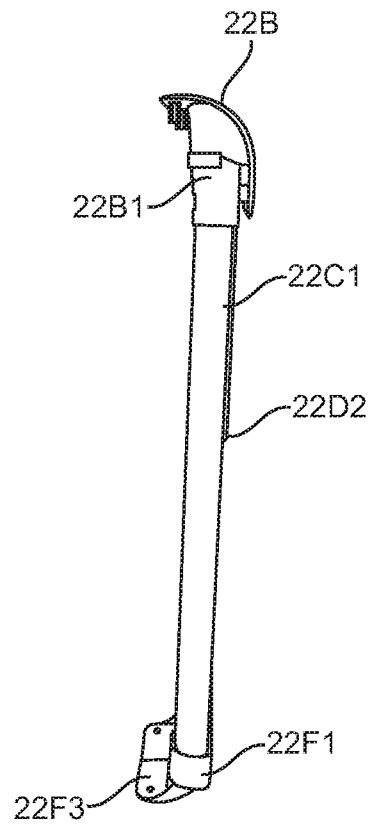

FIG. 5J4

2021240291 01 Oct 2021

32/103

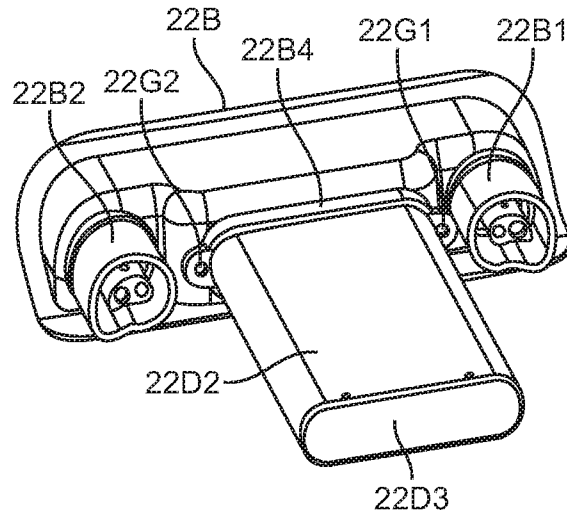

FIG. 5J5

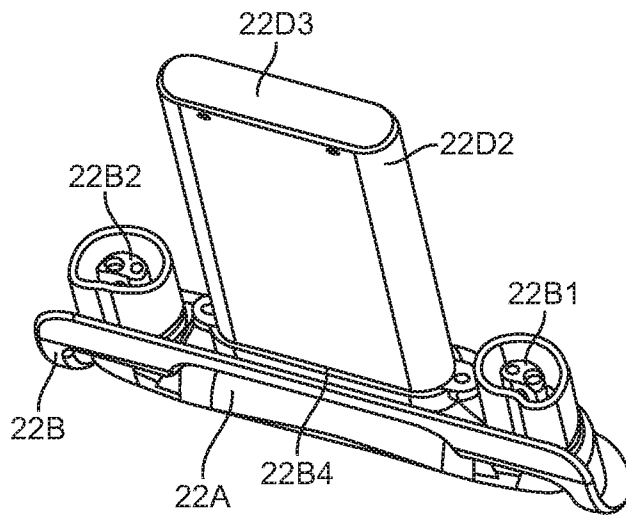

FIG. 5J6

2021240291 01 Oct 2021

33/103

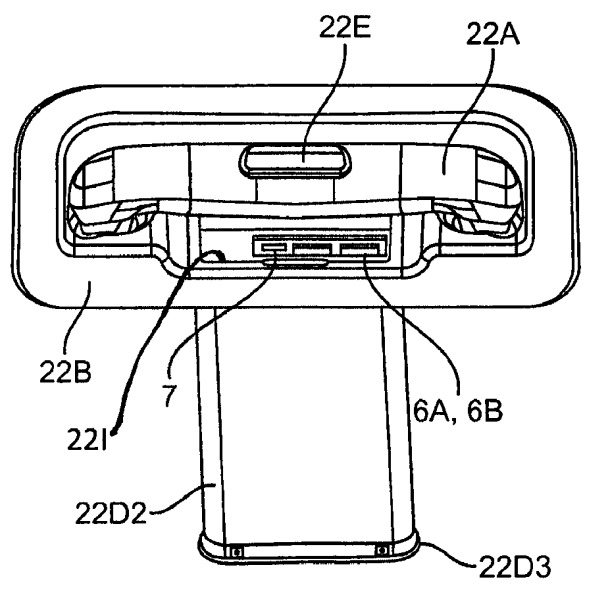

FIG. 5K1

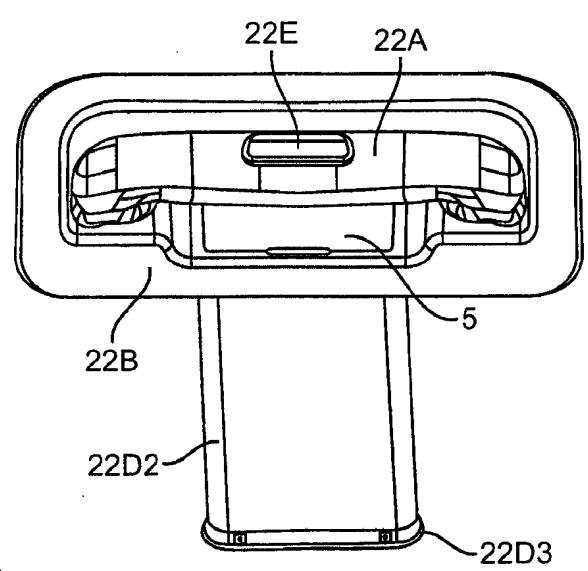

FIG. 5K2

2021240291 01 Oct 2021

34/103

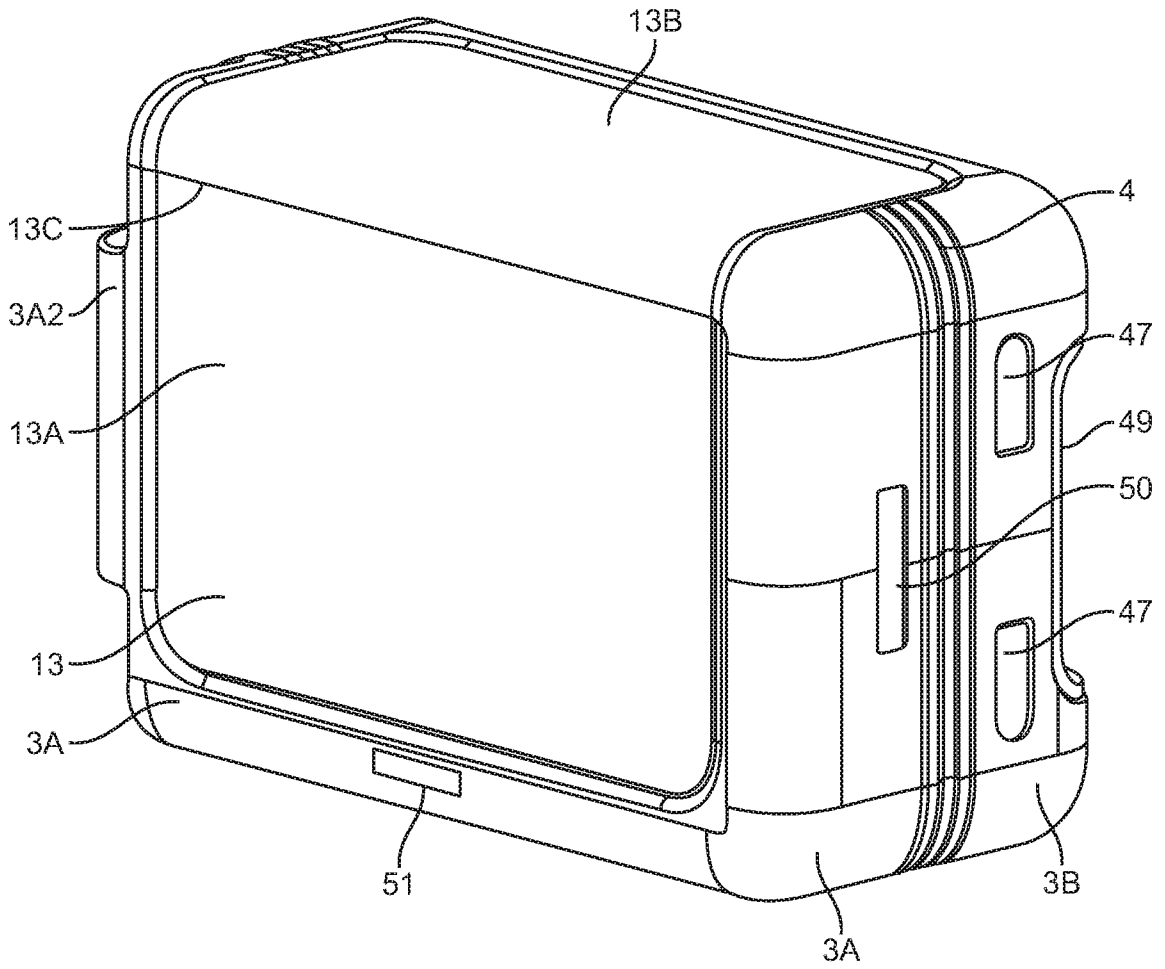

FIG. 6A

2021240291 01 Oct 2021

35/103

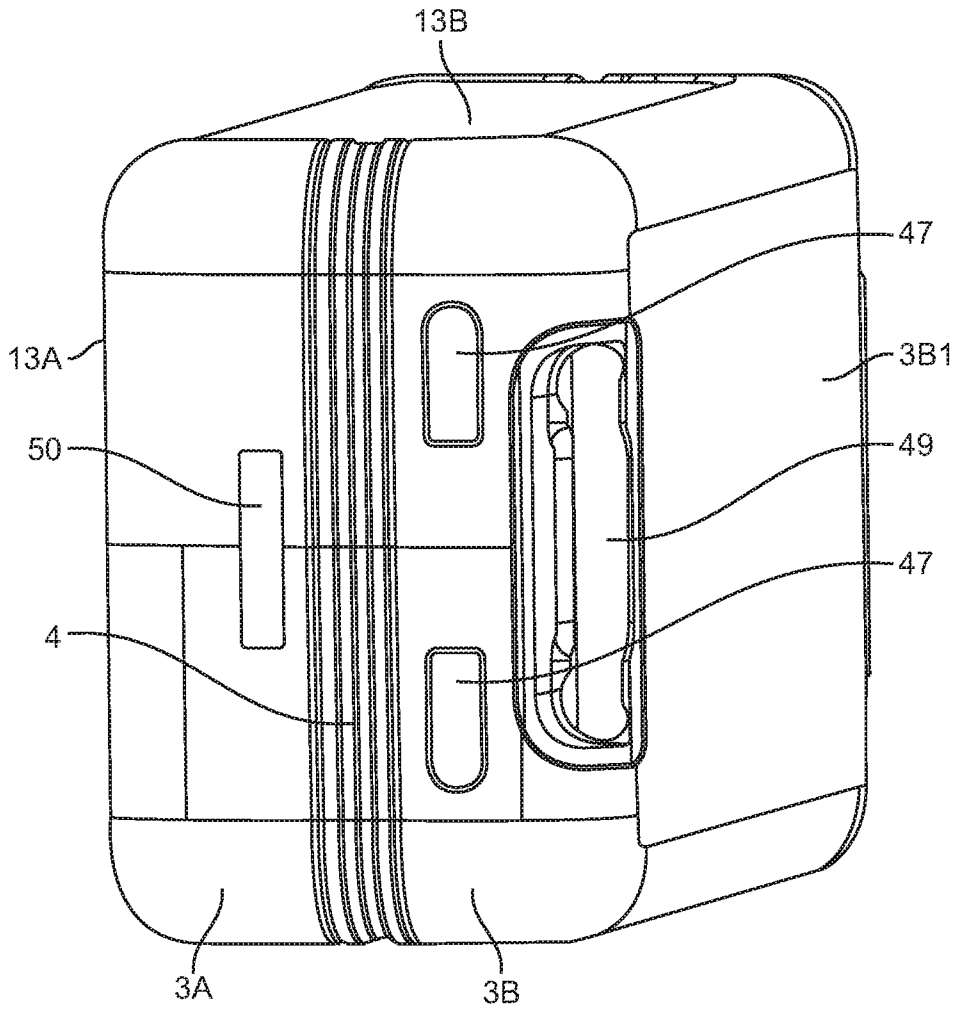

FIG. 6B

2021240291 01 Oct 2021

36/103

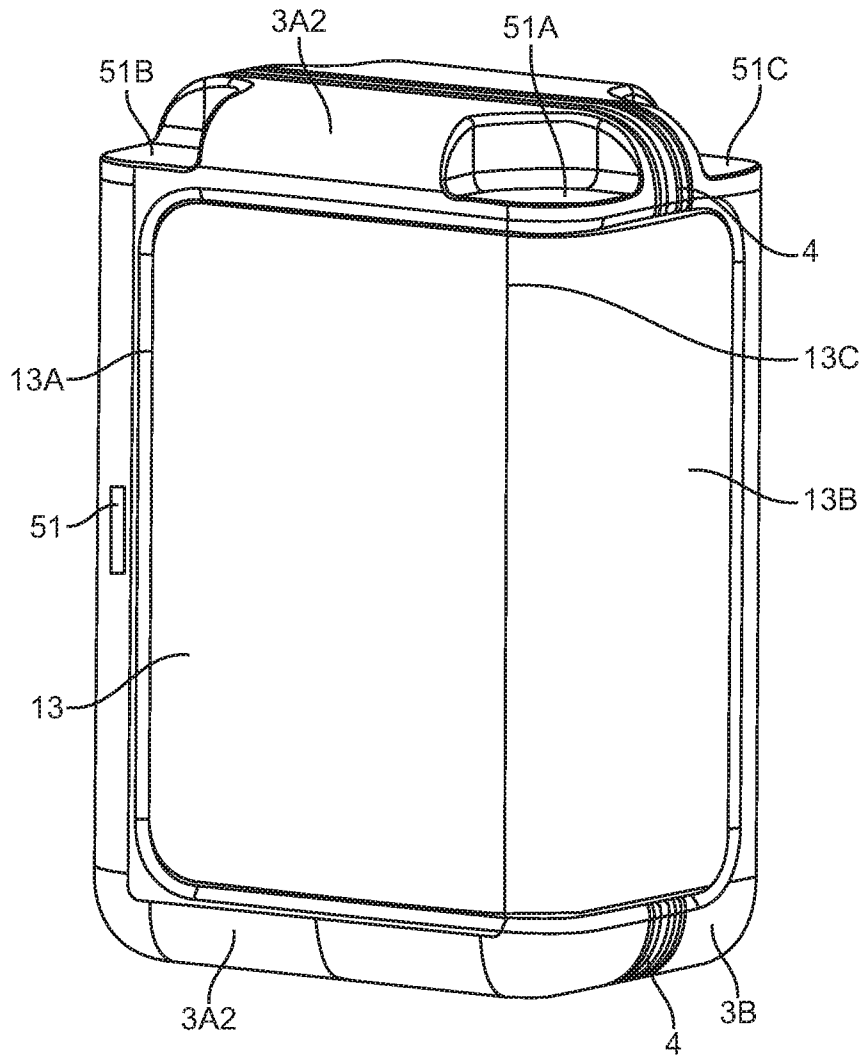

FIG. 6C

2021240291 01 Oct 2021

37/103

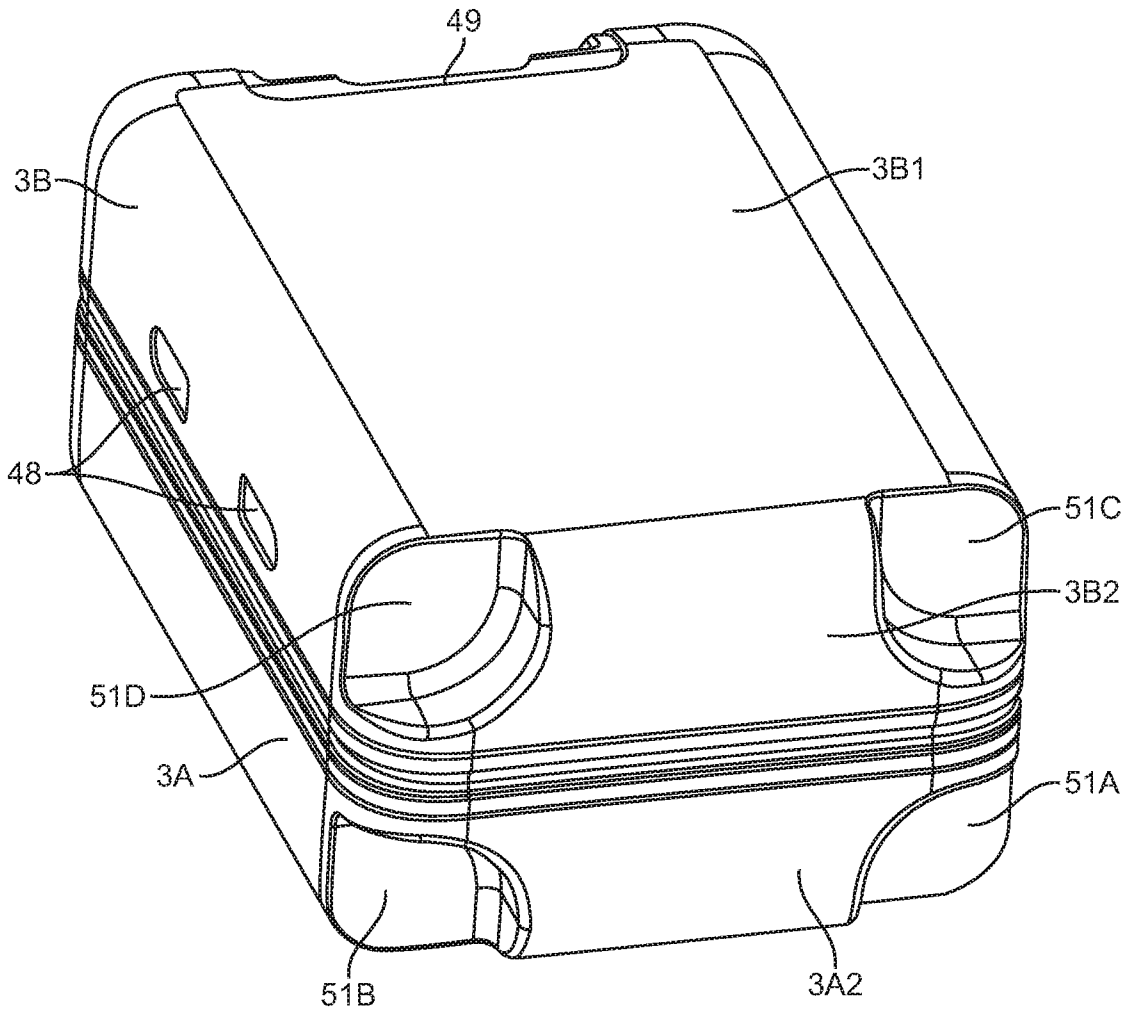

FIG. 6D

2021240291 01 Oct 2021

38/103

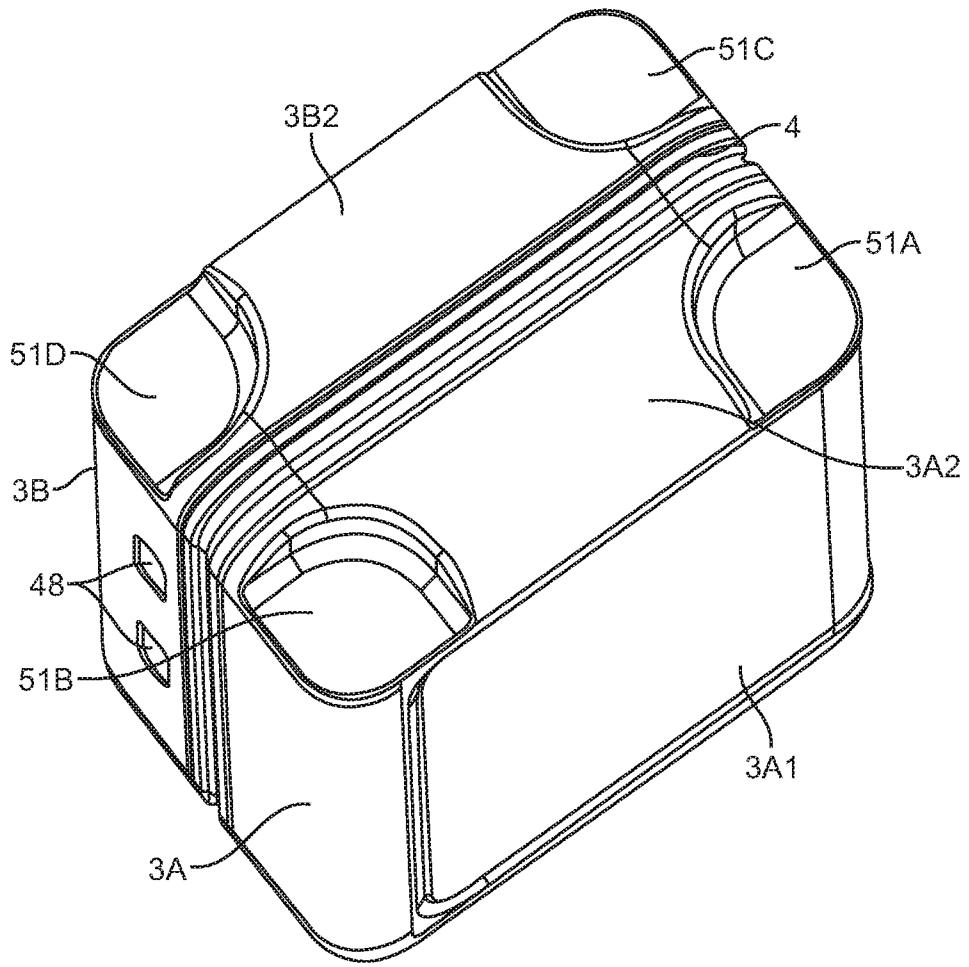

FIG. 6E

2021240291 01 Oct 2021

39/103

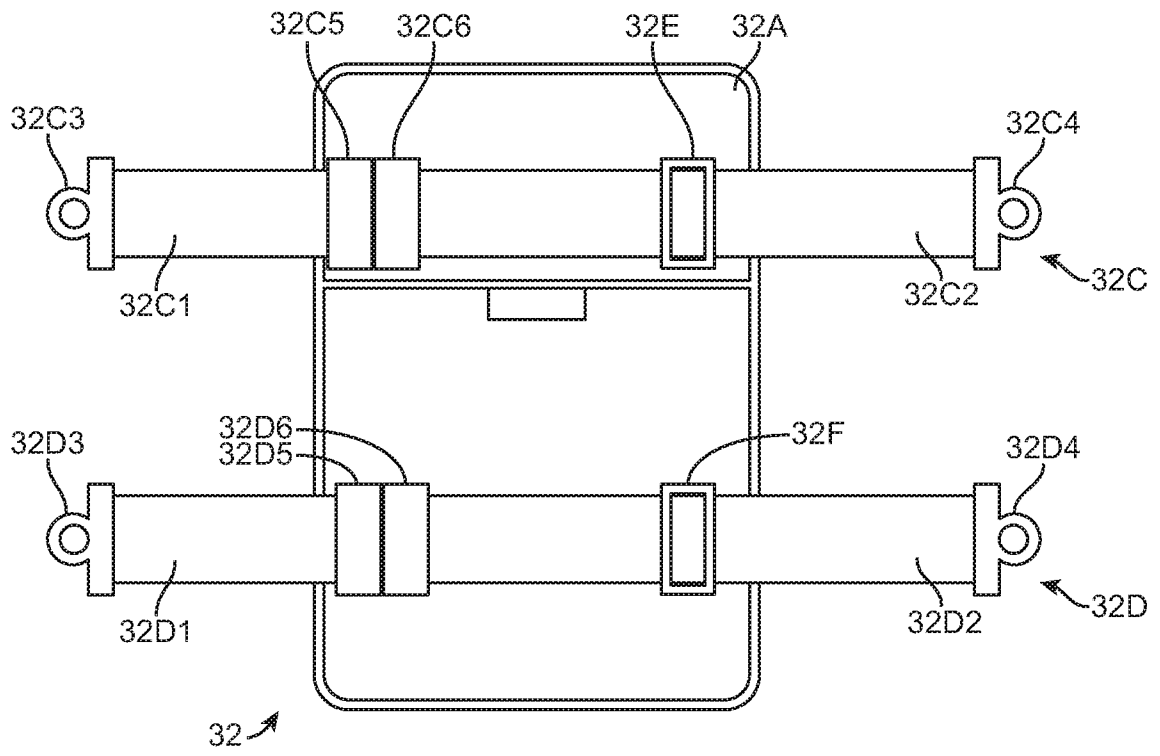

FIG. 7A

2021240291 01 Oct 2021

40/103

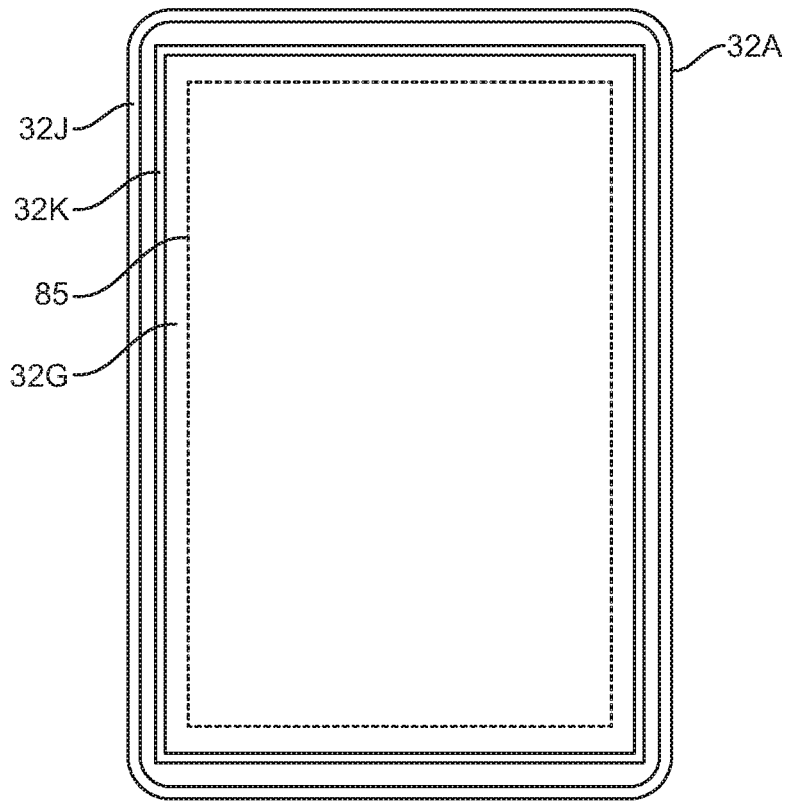

FIG. 7B

2021240291 01 Oct 2021

41/103

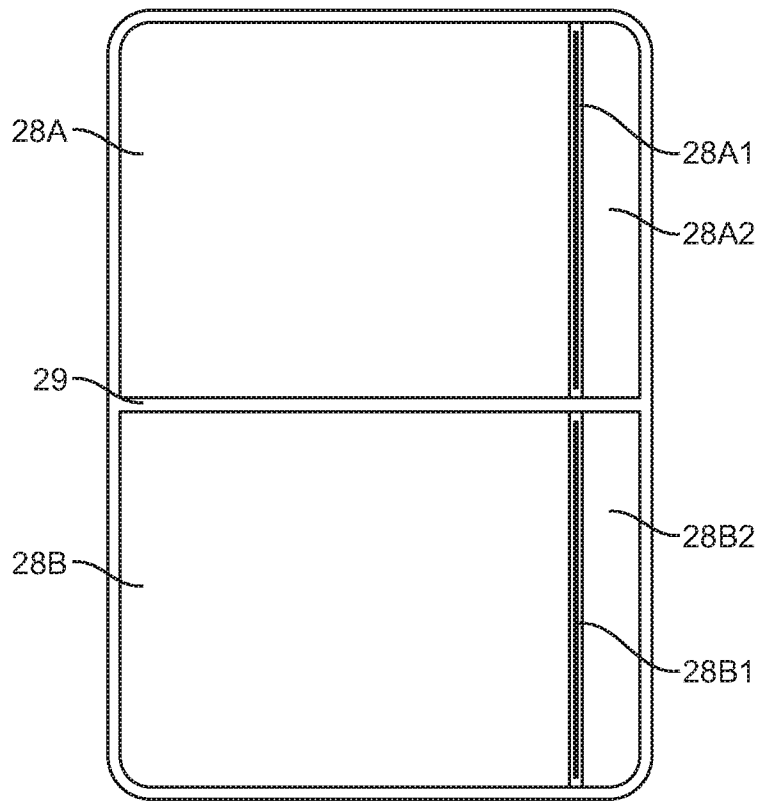

FIG. 8A

2021240291 01 Oct 2021

42/103

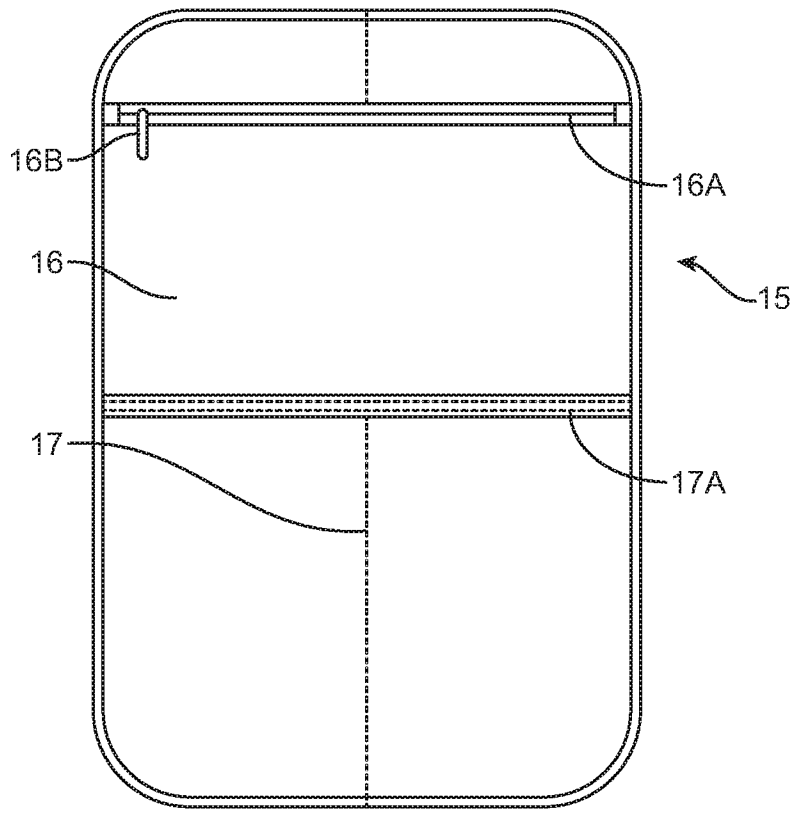

FIG. 8B

43/103

2021240291 01 Oct 2021

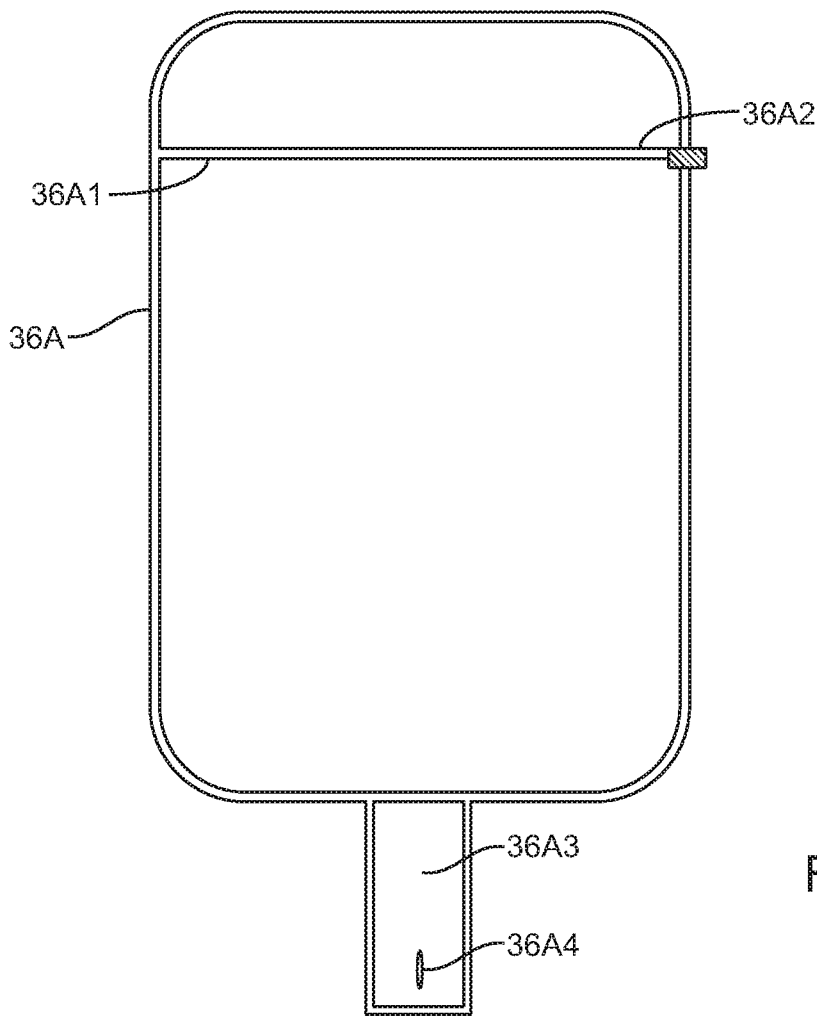

FIG. 9A

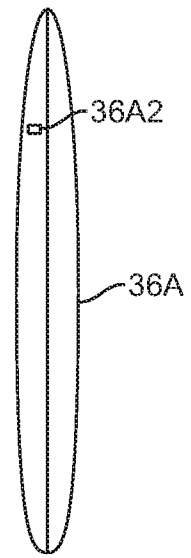

FIG. 9B

2021240291 01 Oct 2021

44/103

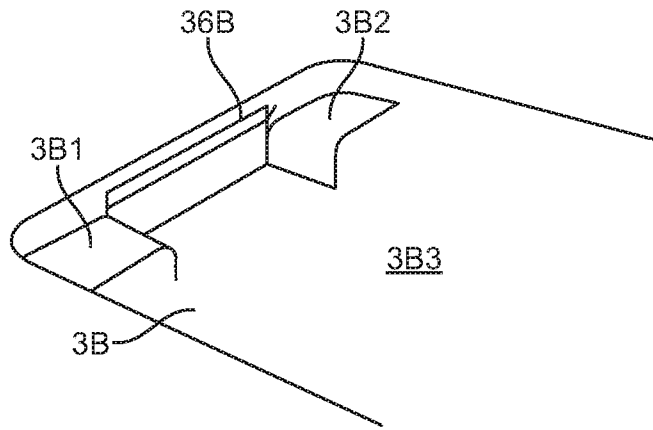

FIG. 9C

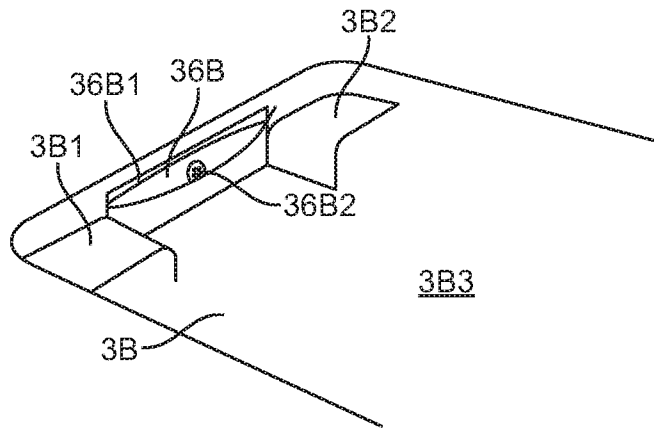

FIG. 9D

2021240291 01 Oct 2021

45/103

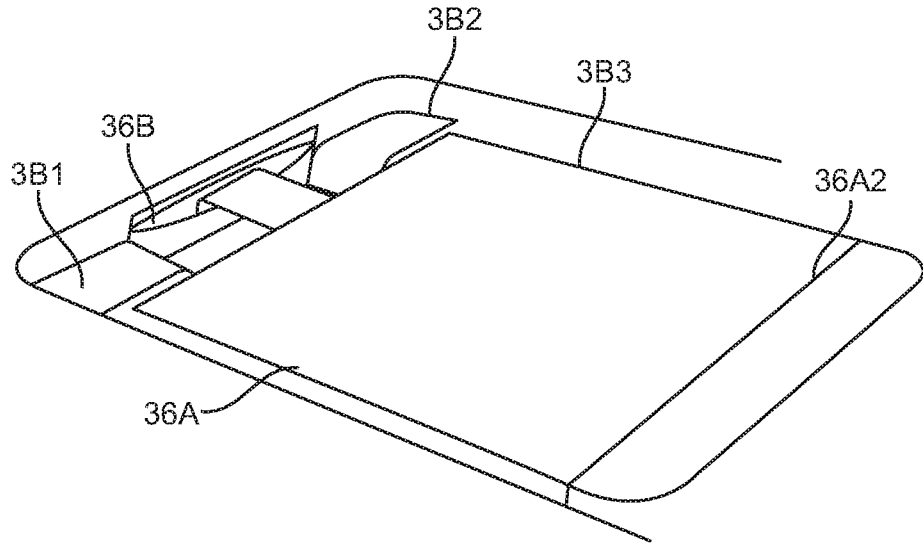

FIG. 9E

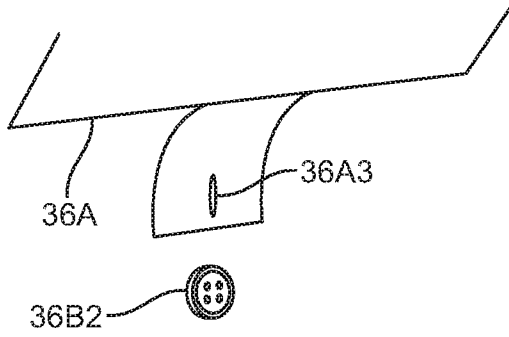

FIG. 9F

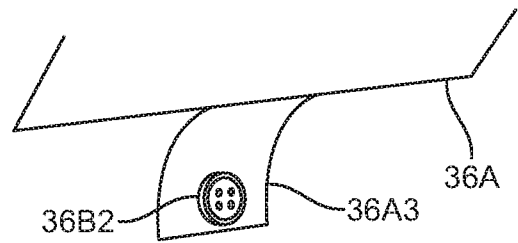

FIG. 9G

2021240291 01 Oct 2021

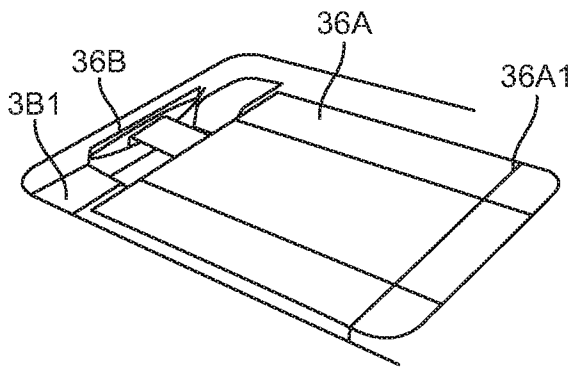

FIG. 10A

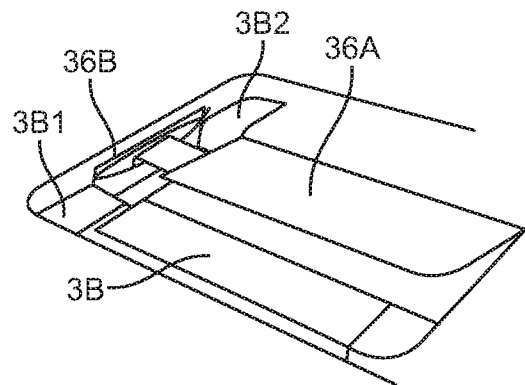

FIG. 10B

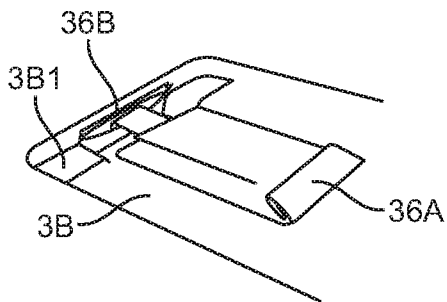

FIG. 10C

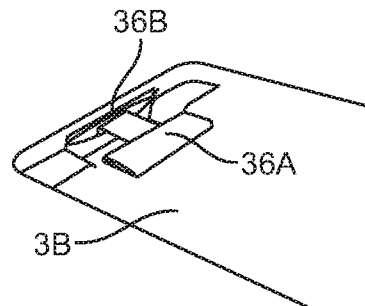

FIG. 10D

2021240291 01 Oct 2021

47/103

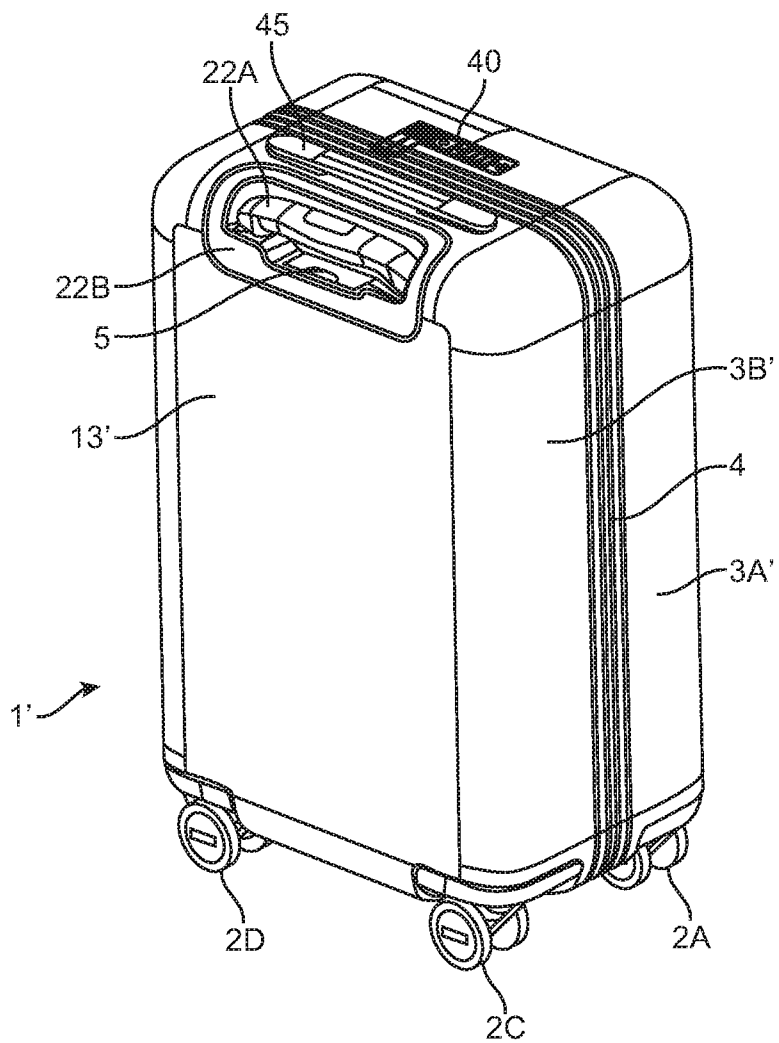

FIG. 11A

2021240291 01 Oct 2021

48/103

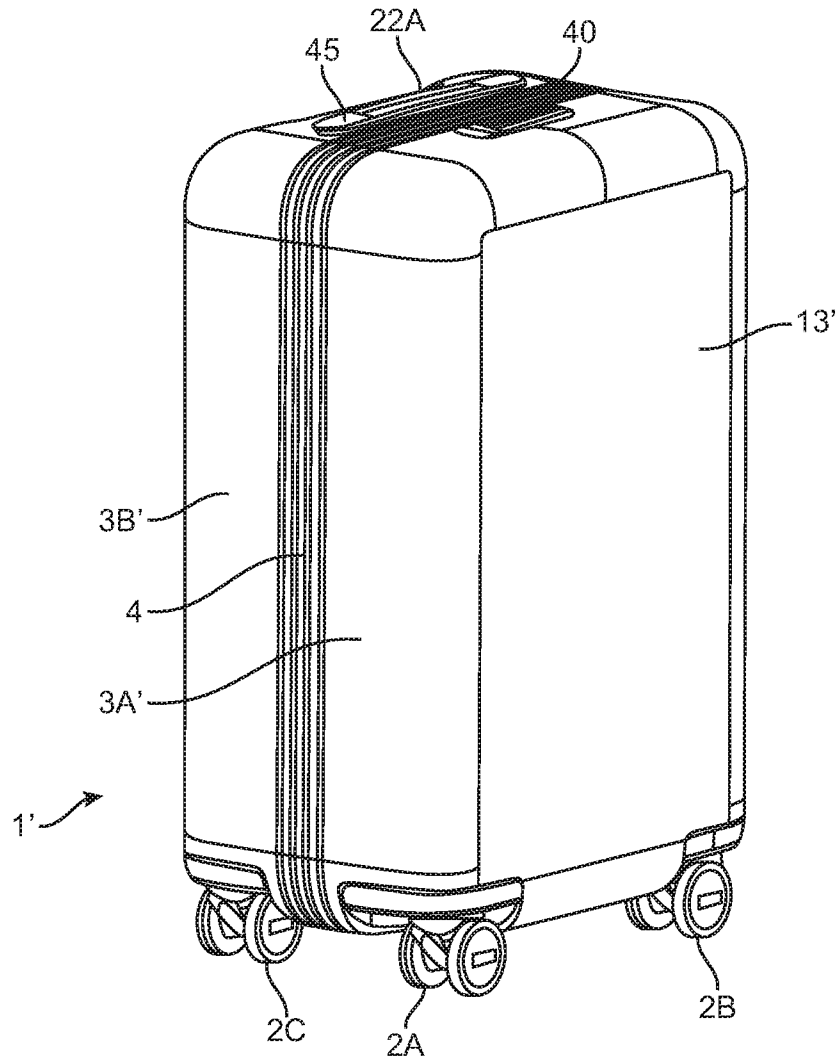

FIG. 11B

2021240291 01 Oct 2021

49/103

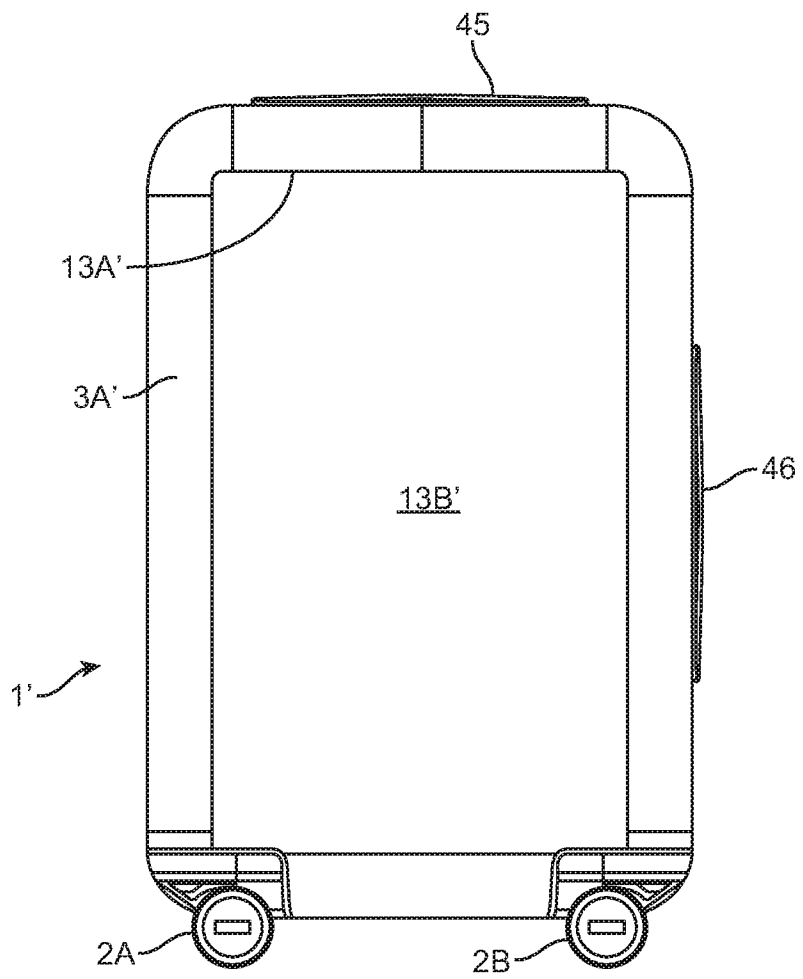

FIG. 11C

2021240291 01 Oct 2021

50/103

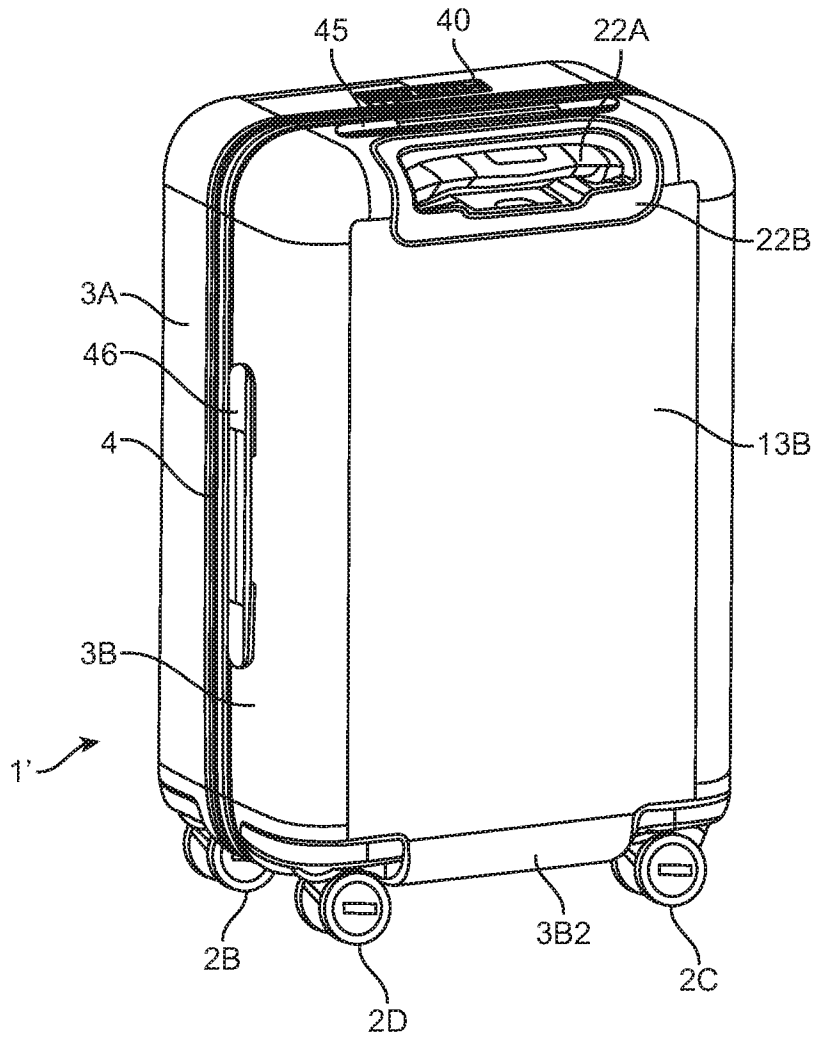

FIG. 11D

2021240291 01 Oct 2021

51/103

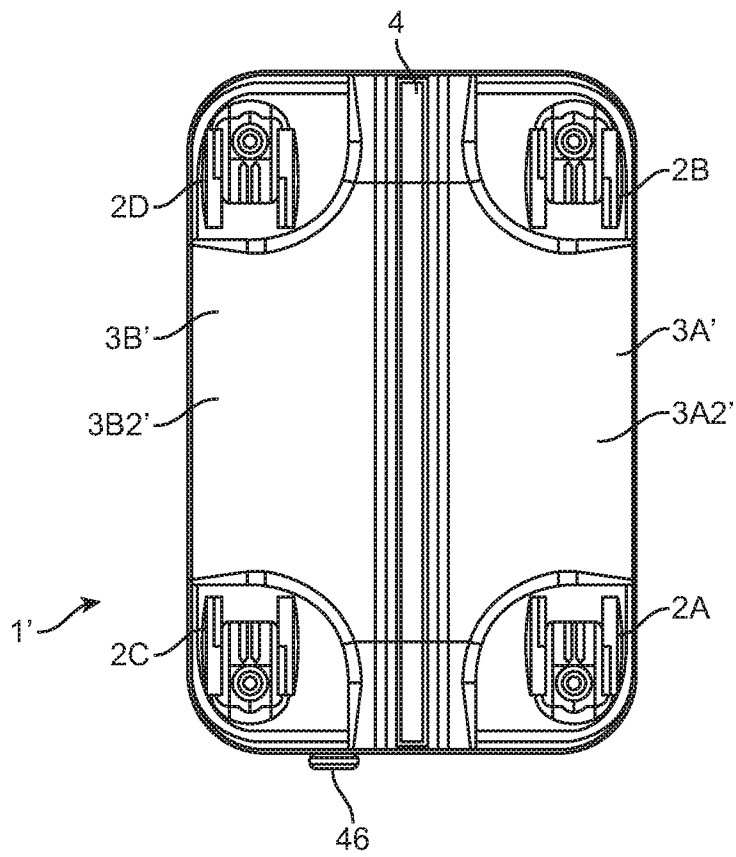

FIG. 11E

2021240291 01 Oct 2021

52/103

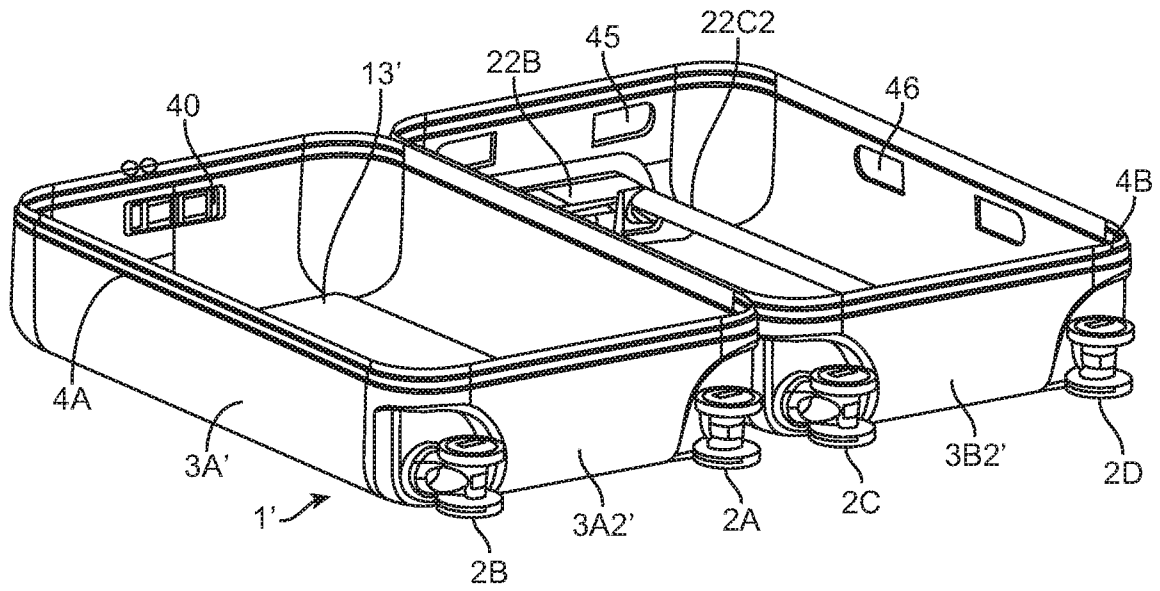

FIG. 12A

2021240291 01 Oct 2021

53/103

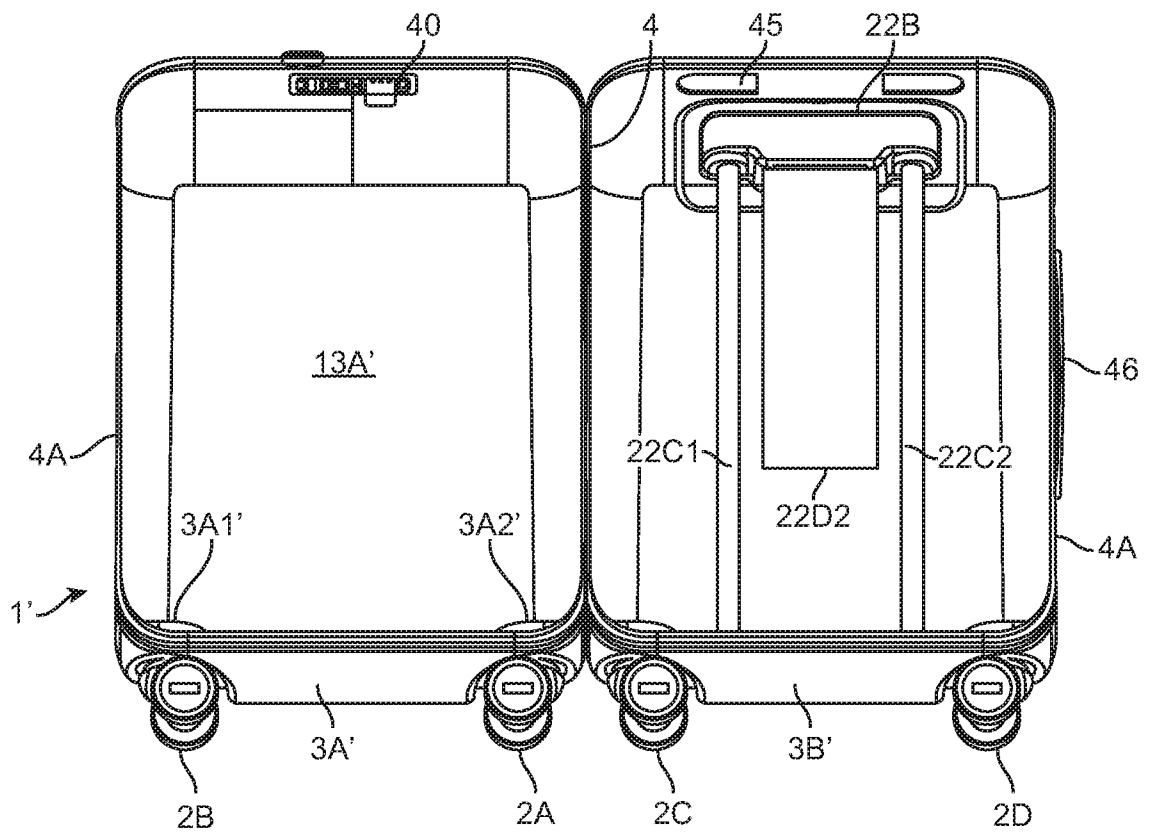

FIG. 12B

2021240291 01 Oct 2021

54/103

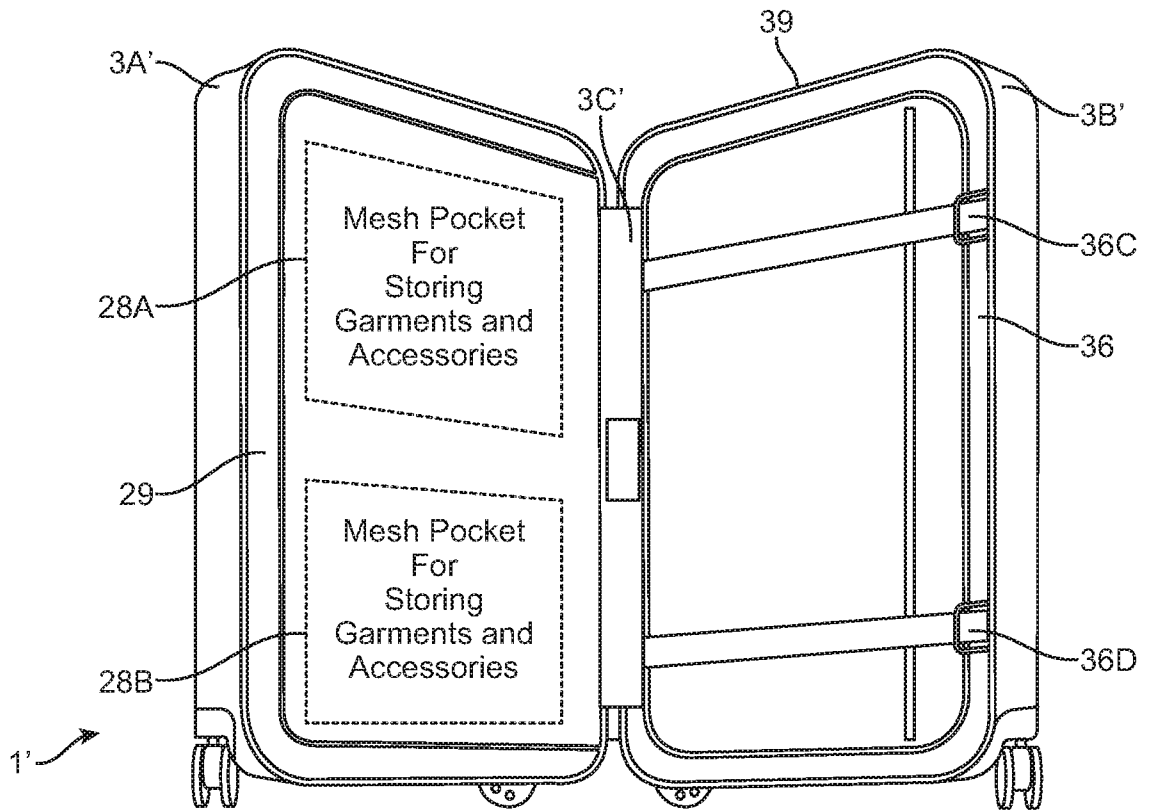

FIG. 12C-1

55/103

2021240291 01 Oct 2021

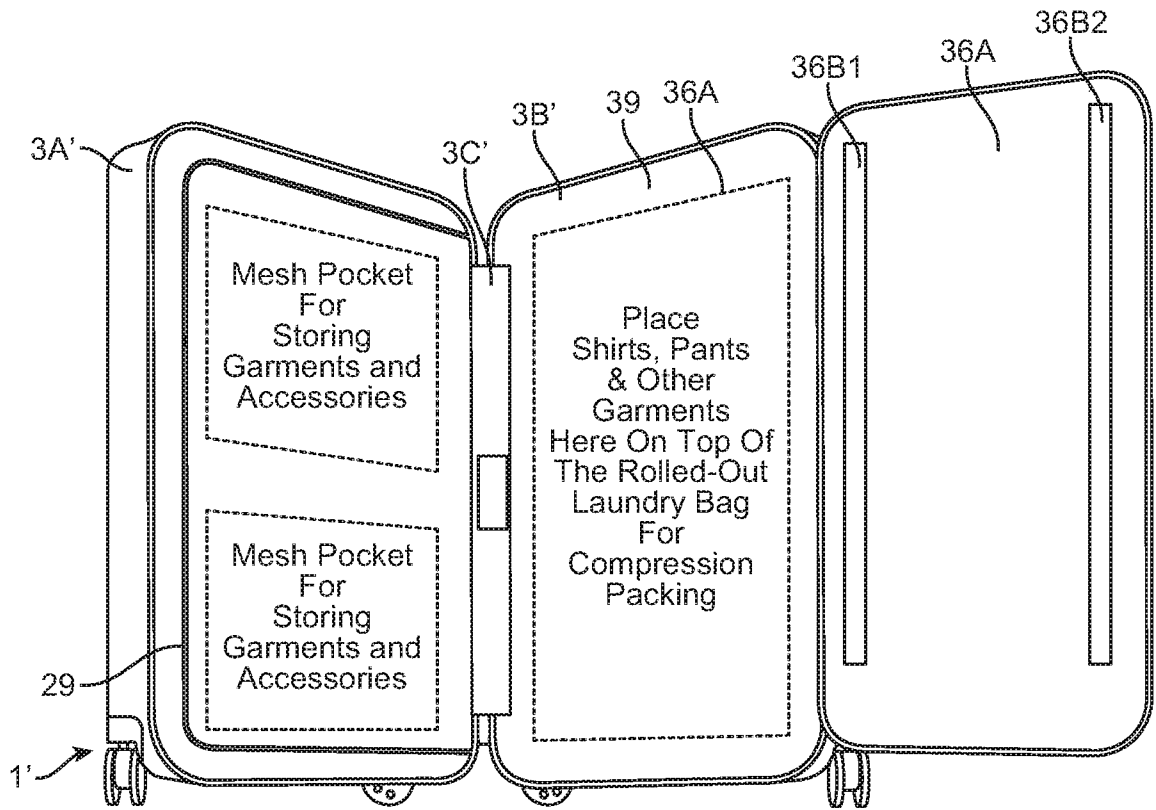

FIG. 12C-2

2021240291 01 Oct 2021

56/103

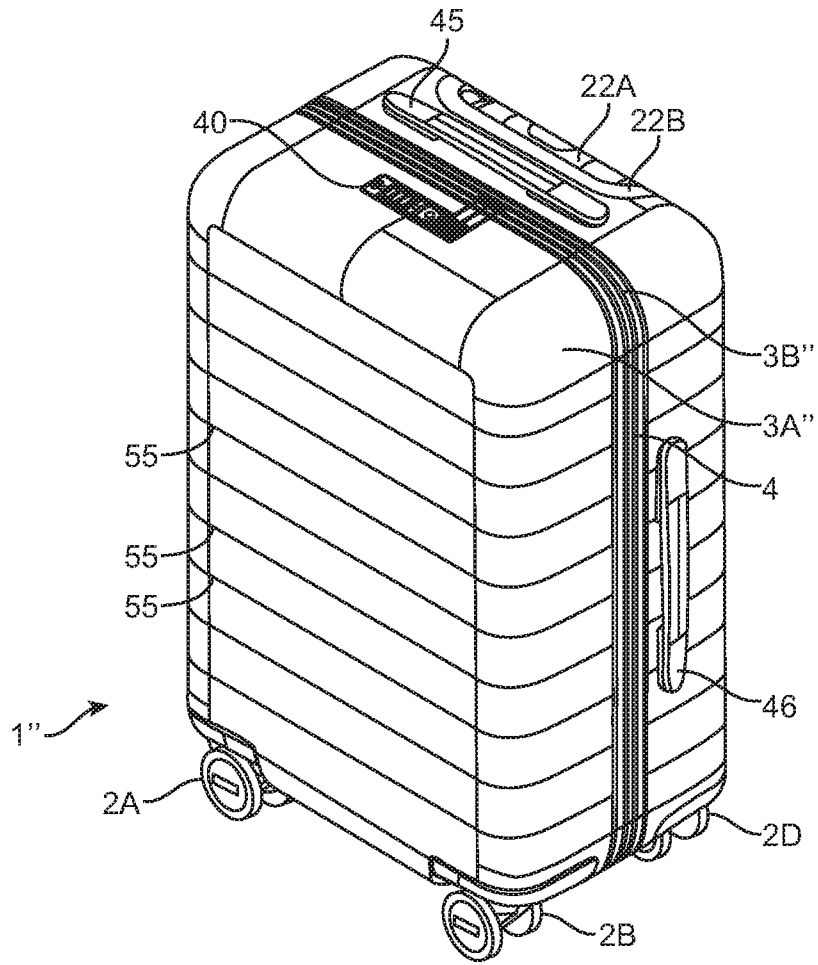

FIG. 13A

2021240291 01 Oct 2021

57/103

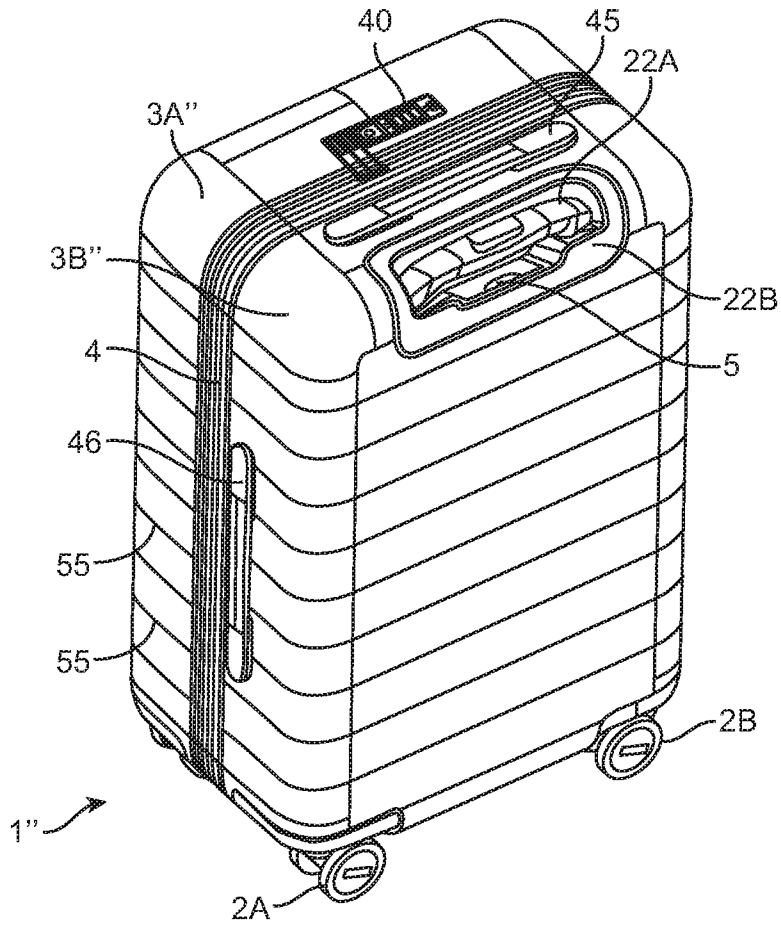

FIG. 13B

2021240291 01 Oct 2021

58/103

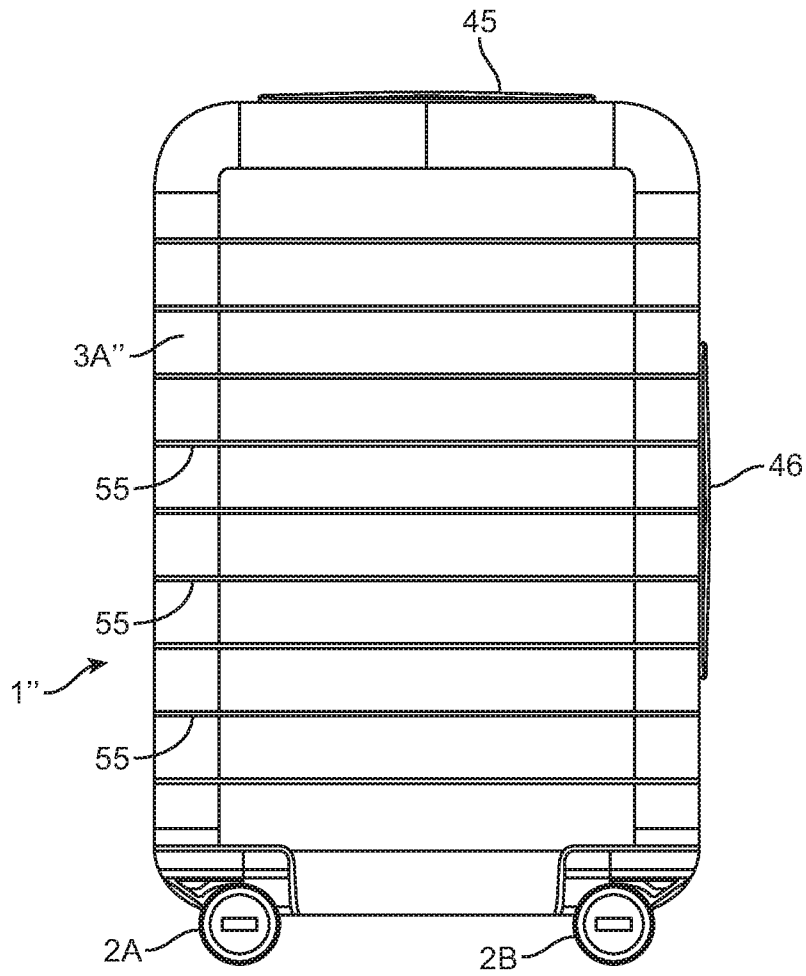

FIG. 13C

2021240291 01 Oct 2021

59/103

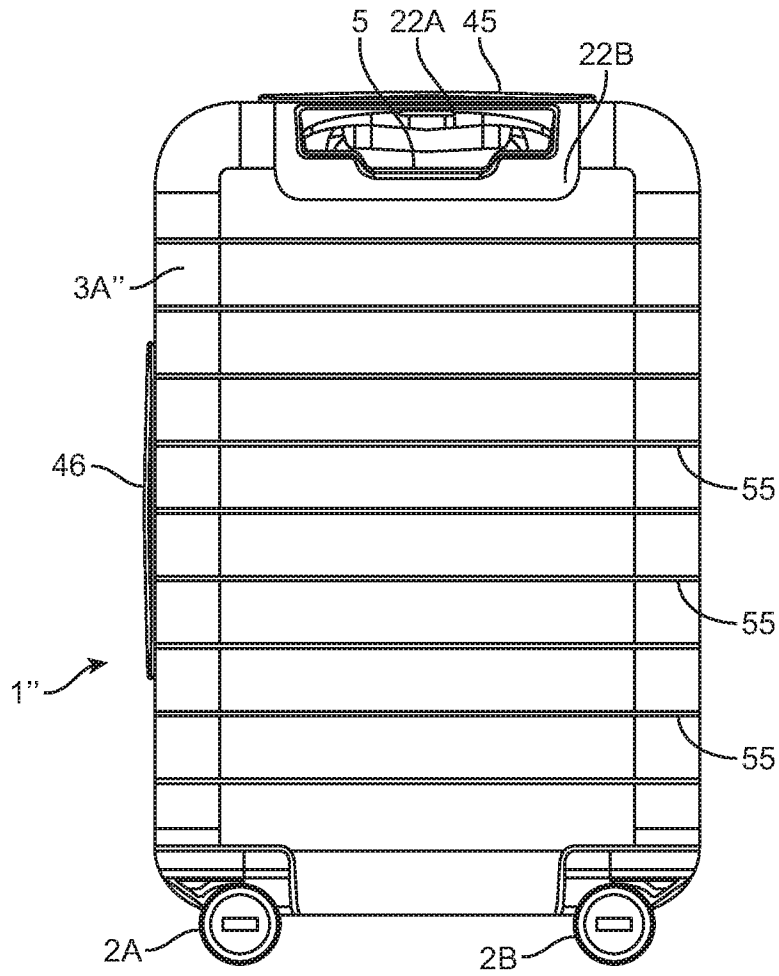

FIG. 13D

2021240291 01 Oct 2021

60/103

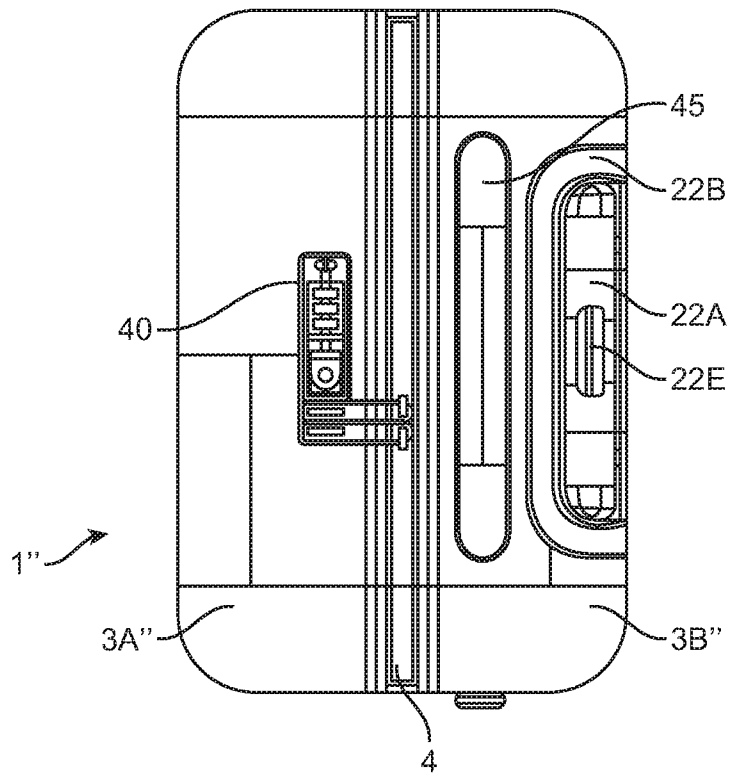

FIG. 13E

2021240291 01 Oct 2021

61/103

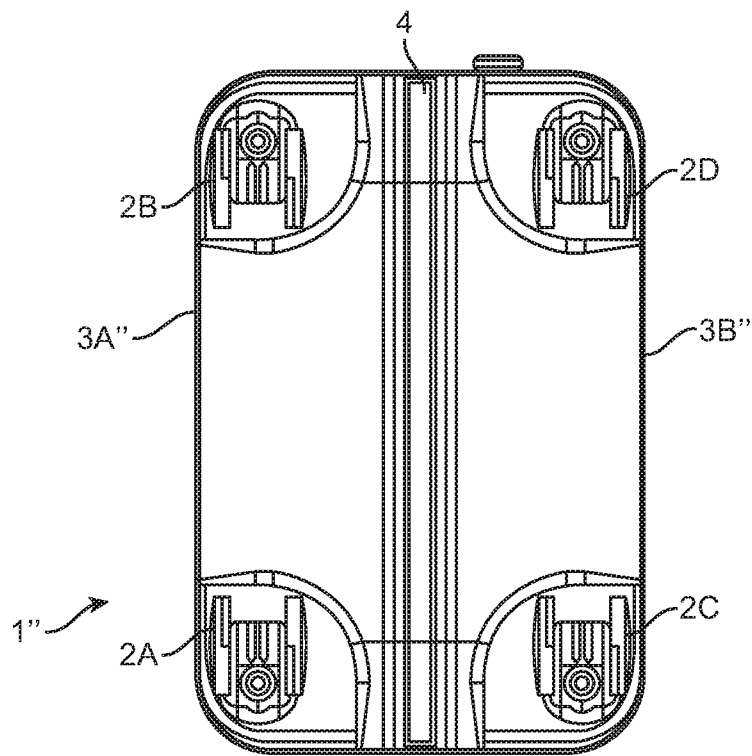

FIG. 13F

2021240291 01 Oct 2021

62/103

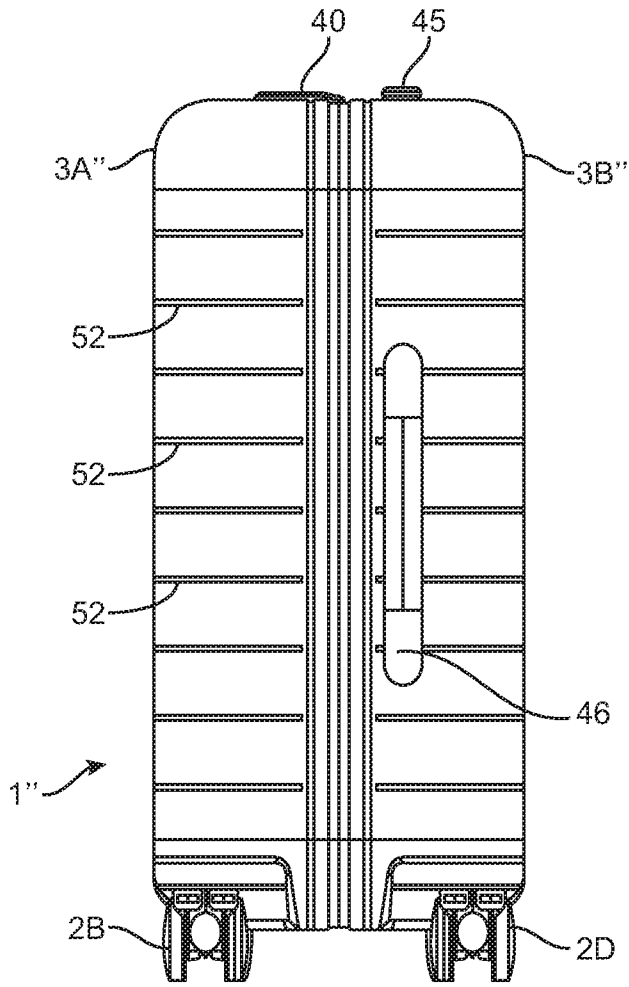

FIG.13G

2021240291 01 Oct 2021

63/103

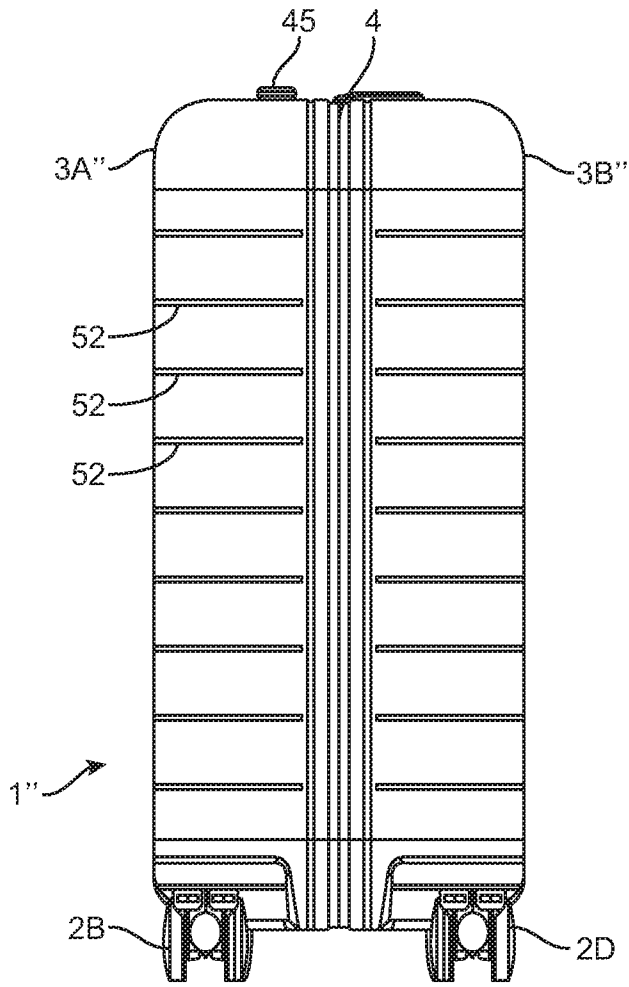

FIG.13H

2021240291 01 Oct 2021

64/103

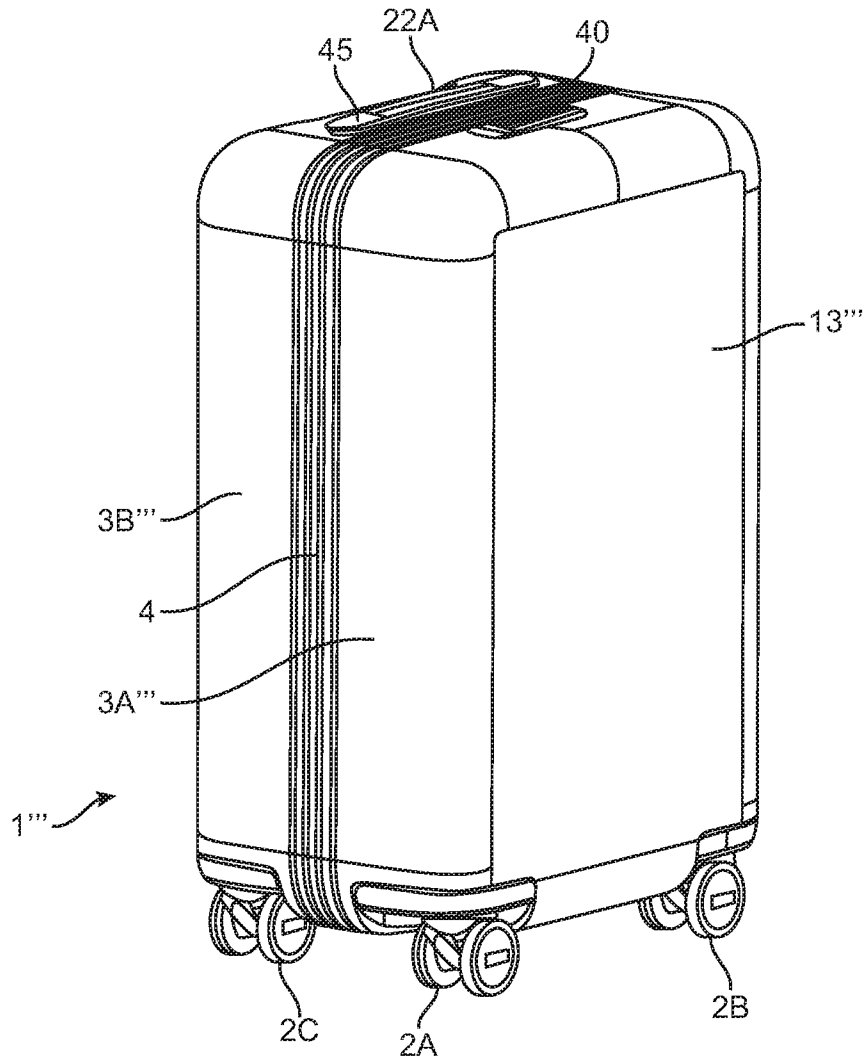

FIG. 14A

2021240291 01 Oct 2021

65/103

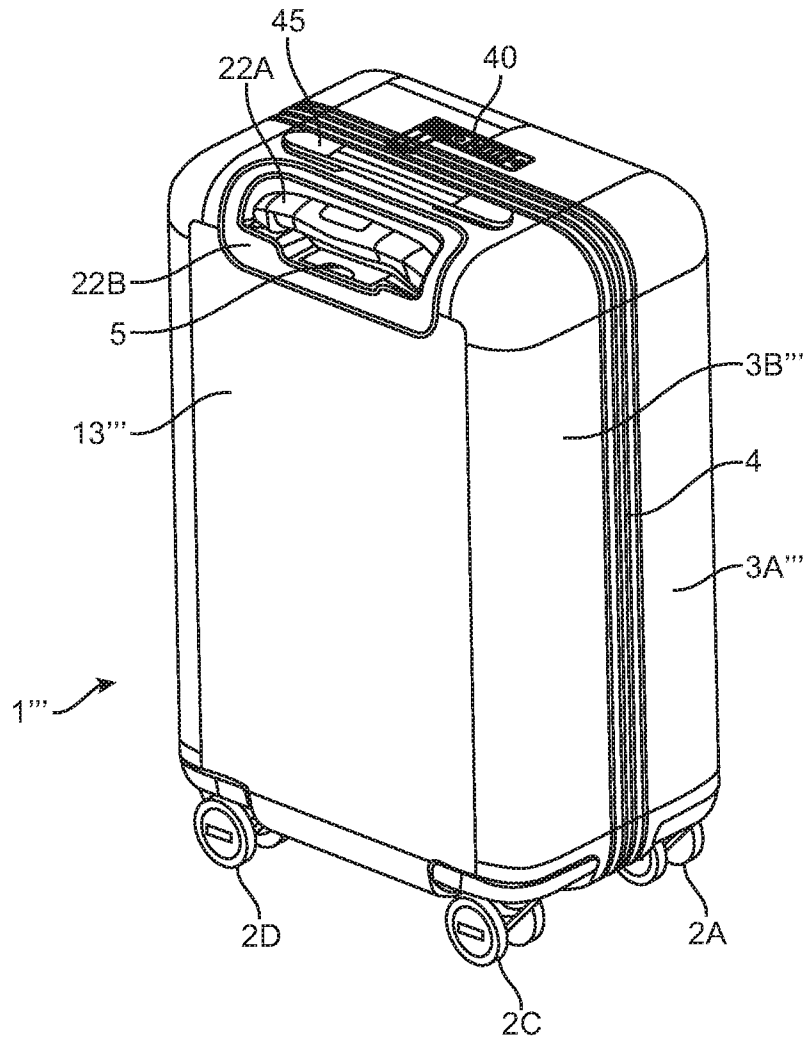

FIG. 14B

2021240291 01 Oct 2021

66/103

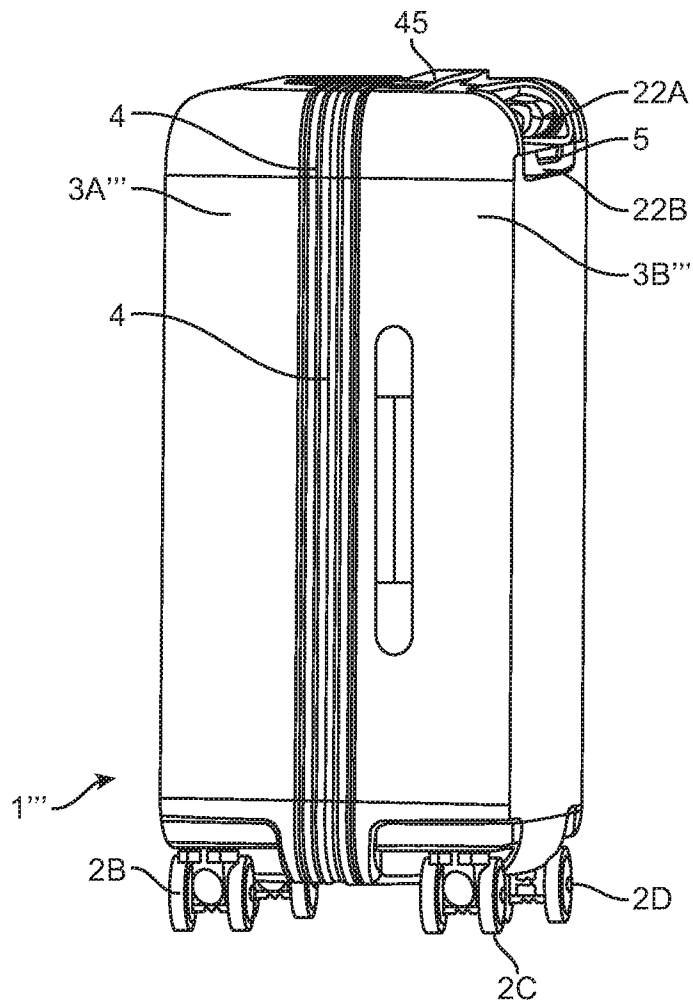

FIG. 14C

2021240291 01 Oct 2021

67/103

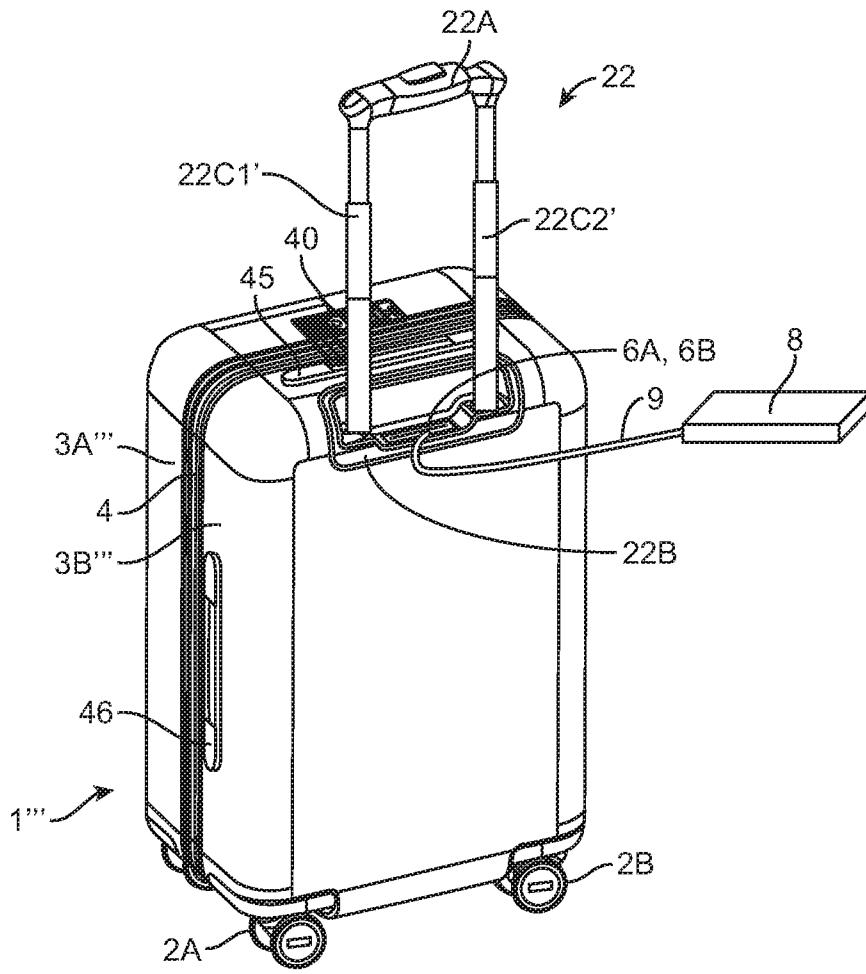

FIG. 14D

2021240291 01 Oct 2021

68/103

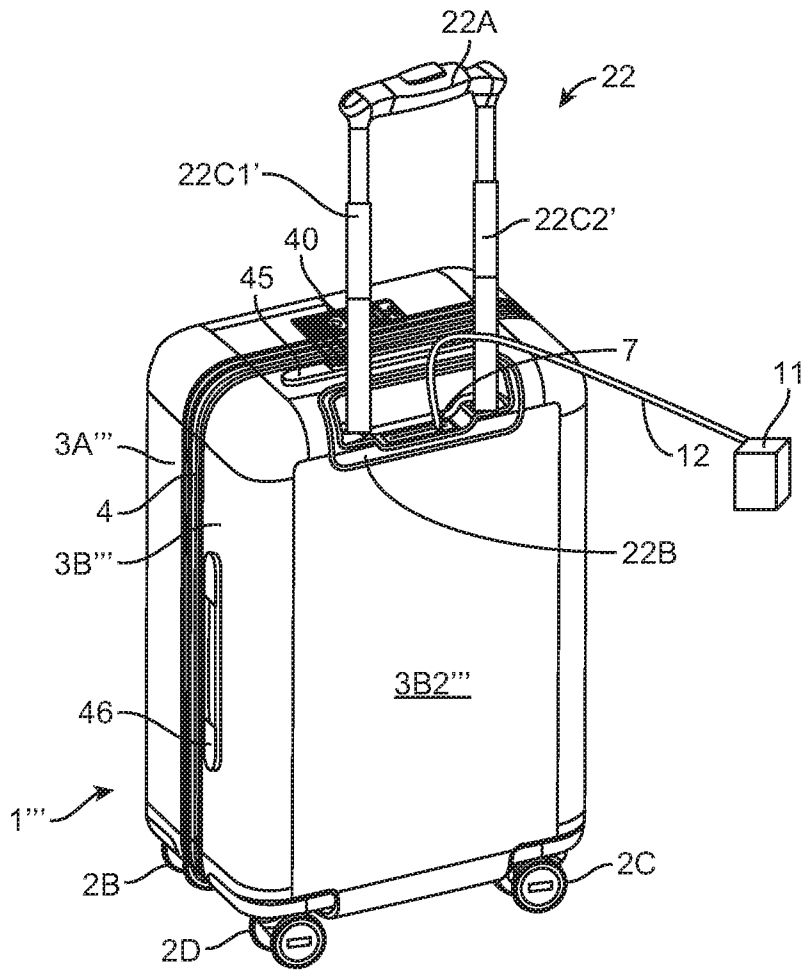

FIG. 14E

69/103

2021240291 01 Oct 2021

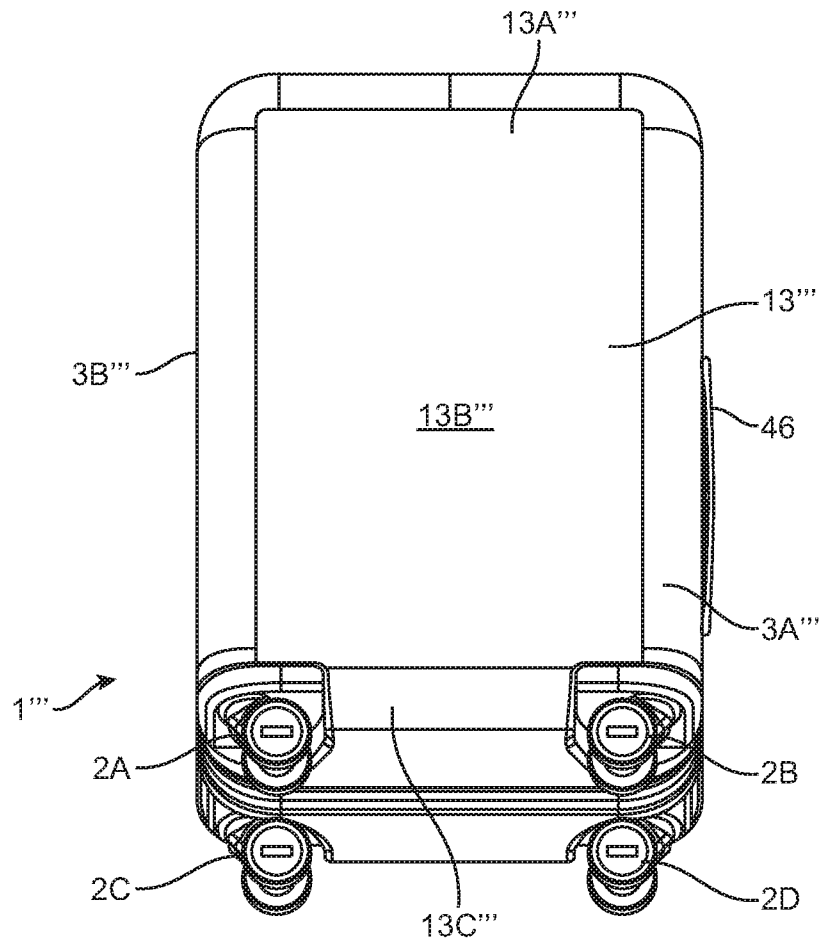

FIG. 14F

2021240291 01 Oct 2021

70/103

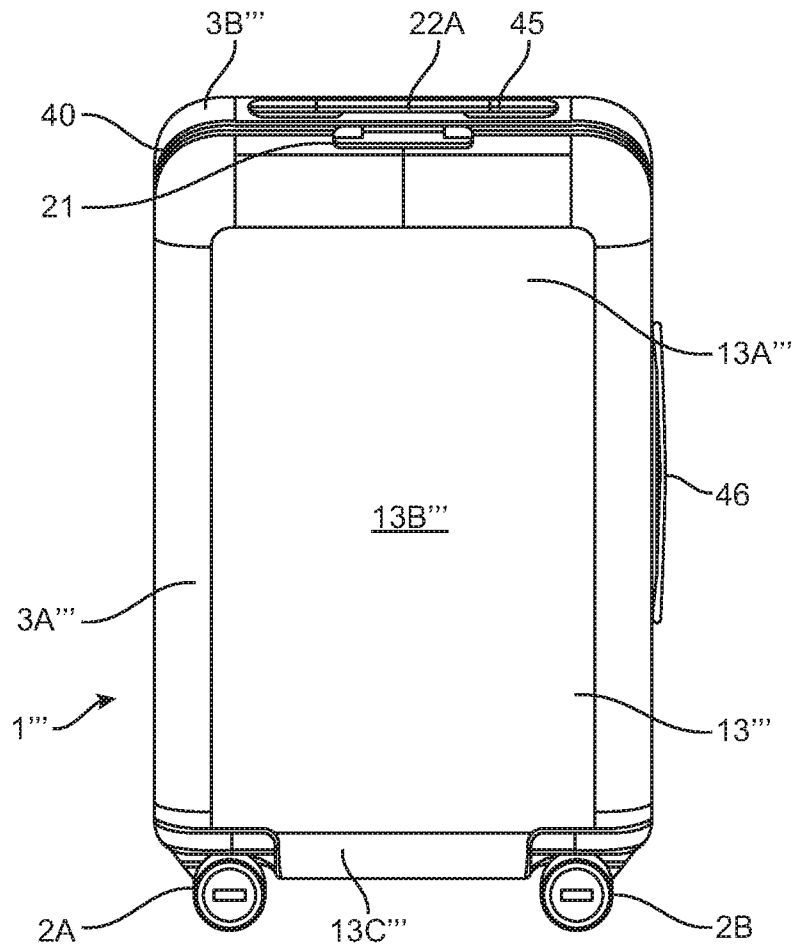

FIG. 14G

2021240291 01 Oct 2021

71/103

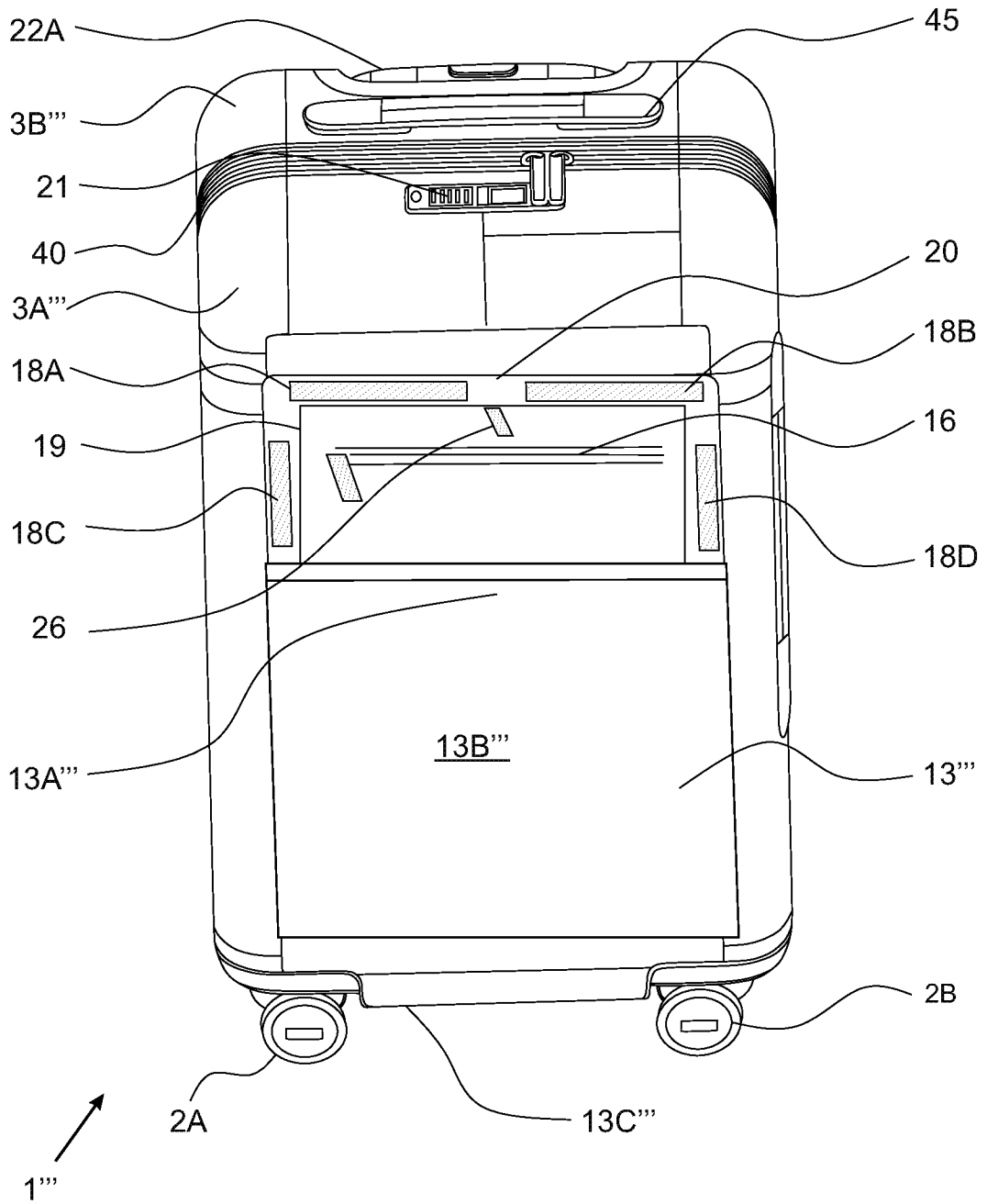

FIG. 14H1

72/103

2021240291 01 Oct 2021

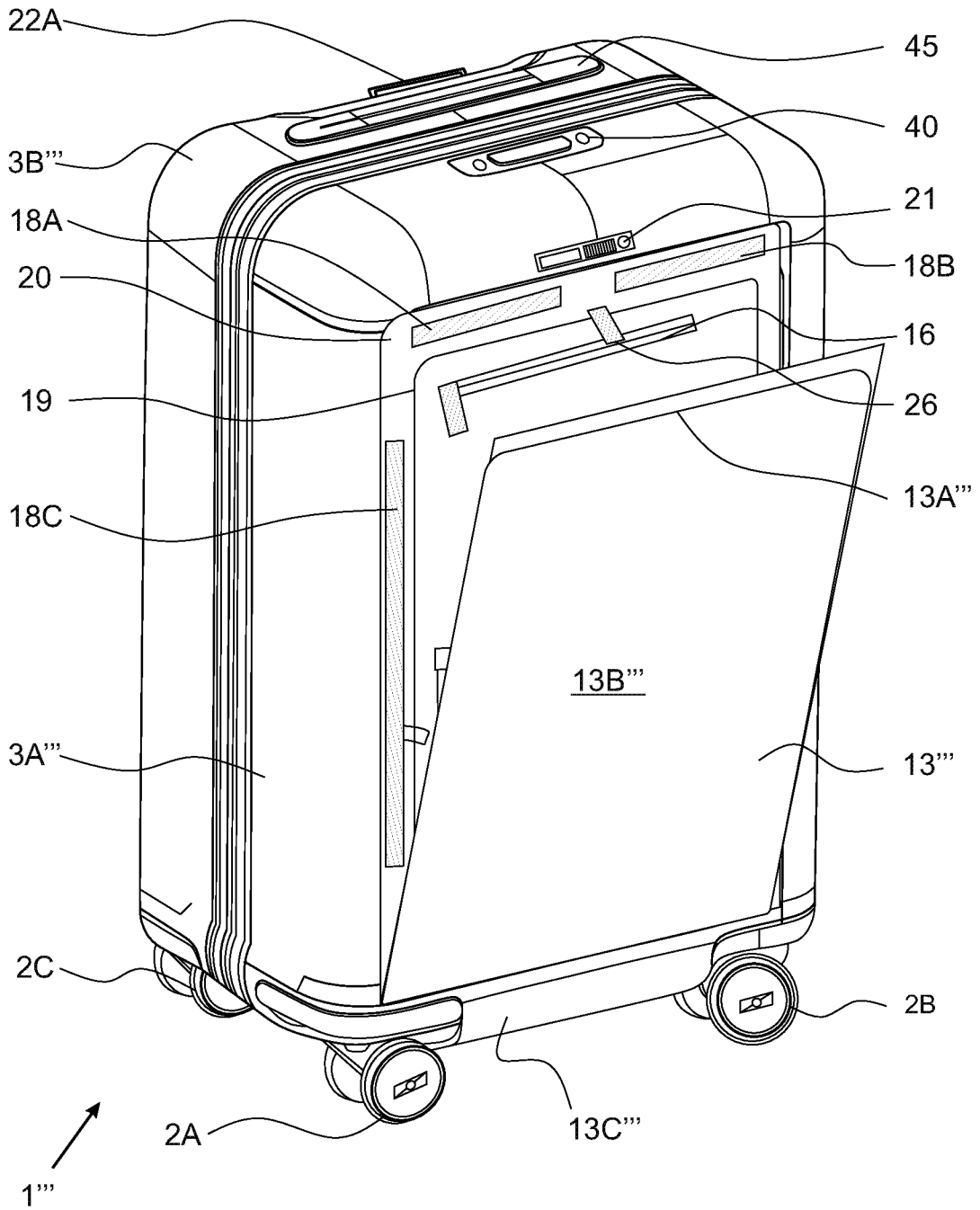

FIG. 14H2

73/103

2021240291 01 Oct 2021

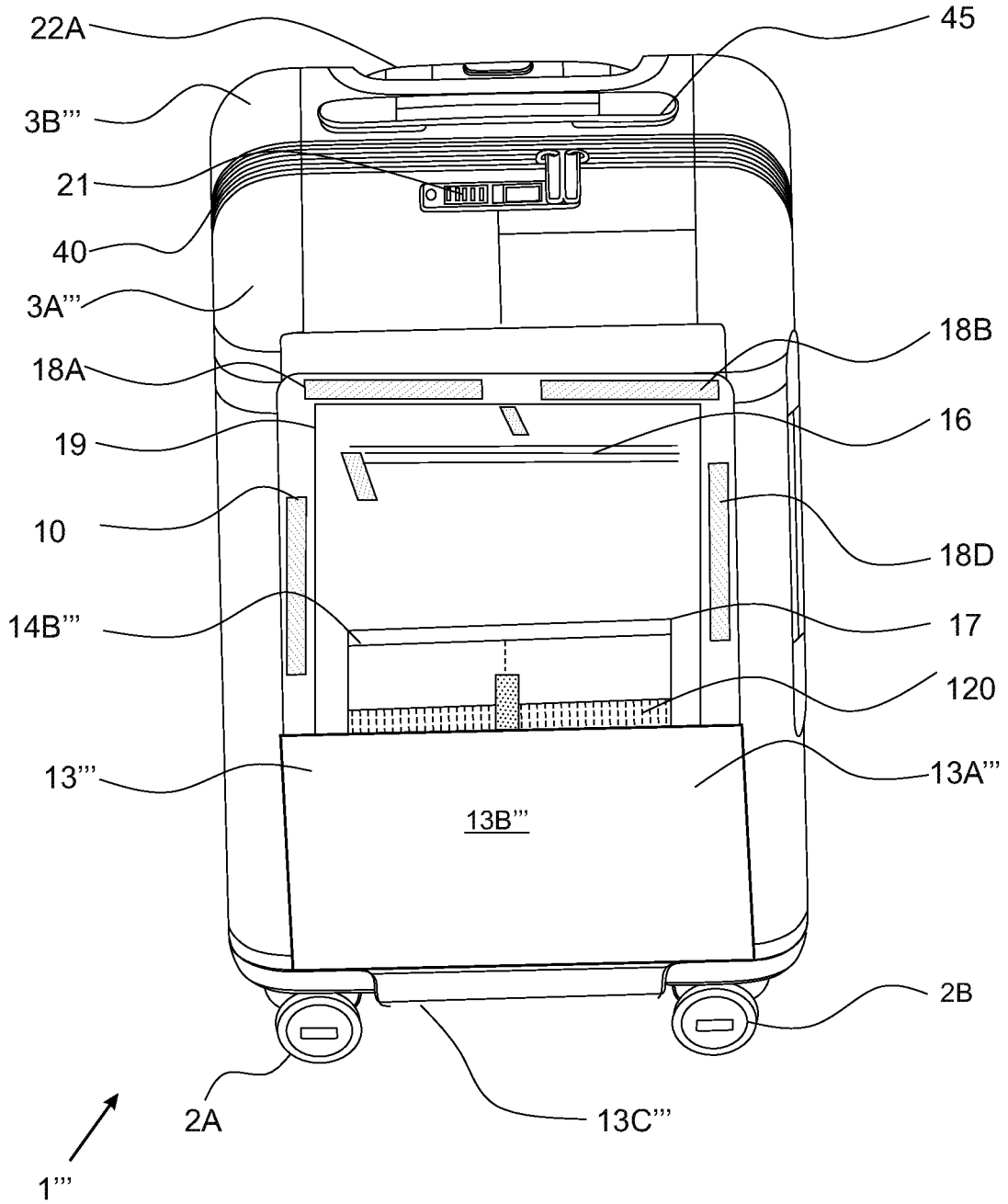

FIG. 14I1

74/103

2021240291 01 Oct 2021

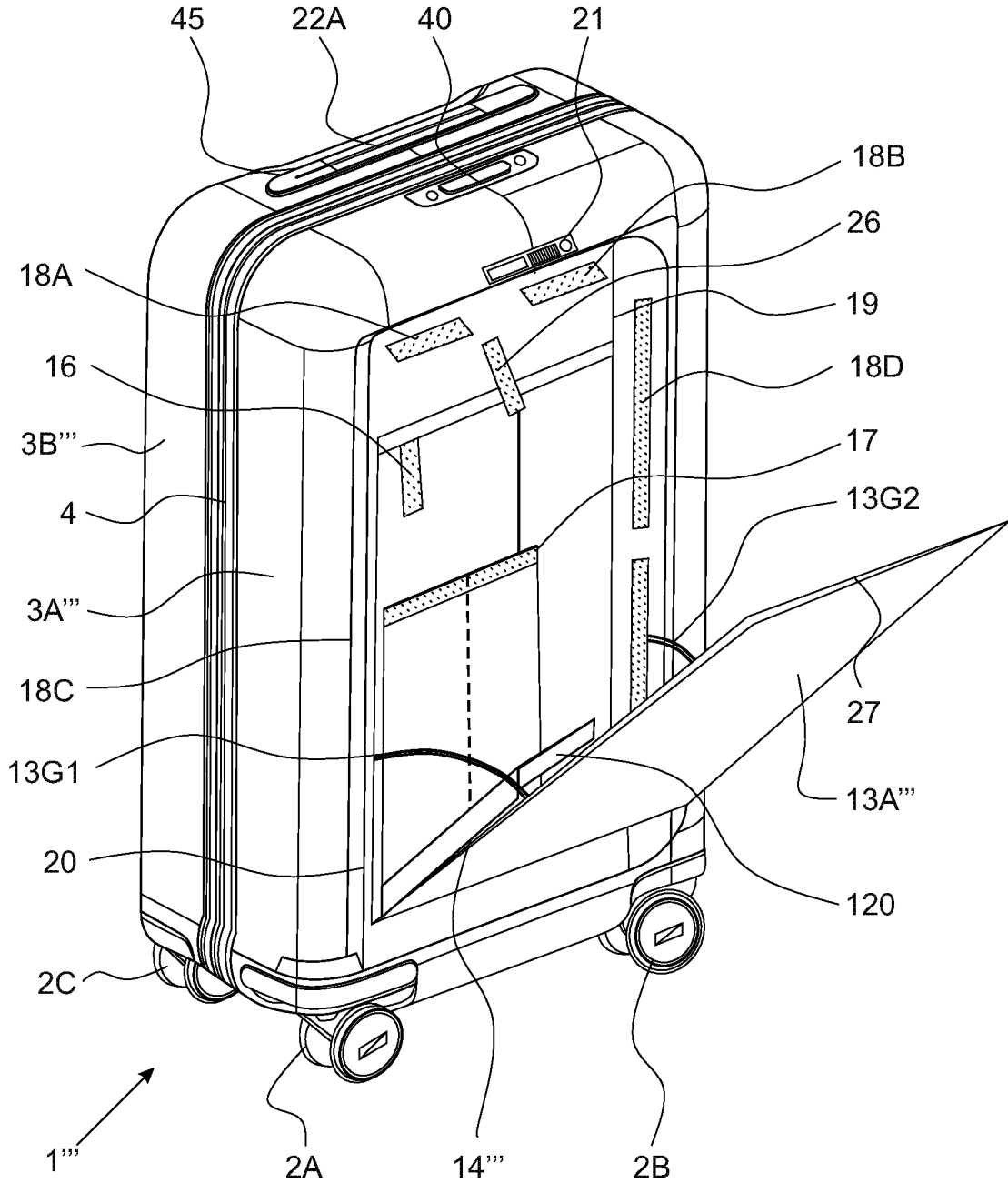

FIG. 14I2

2021240291 01 Oct 2021

75/103

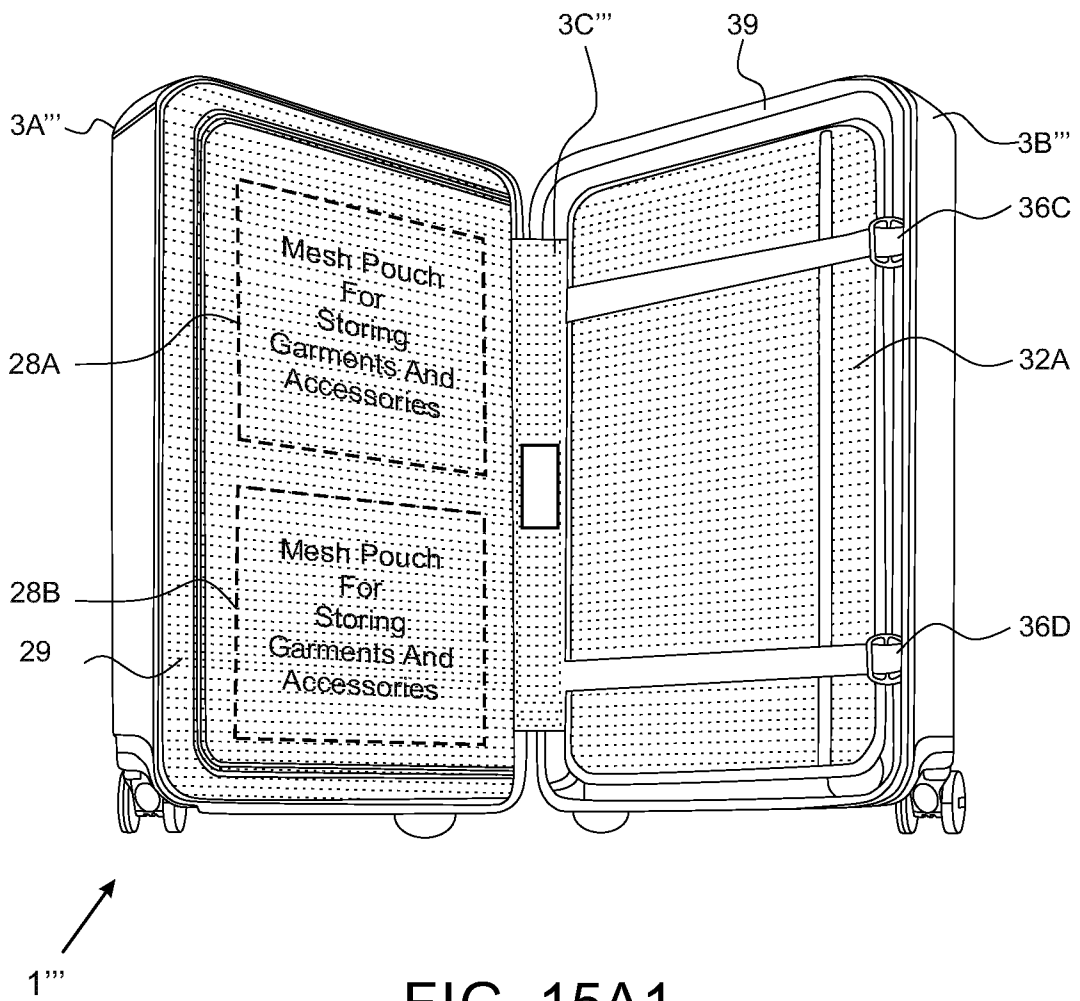

FIG. 15A1

2021240291 01 Oct 2021

76/103

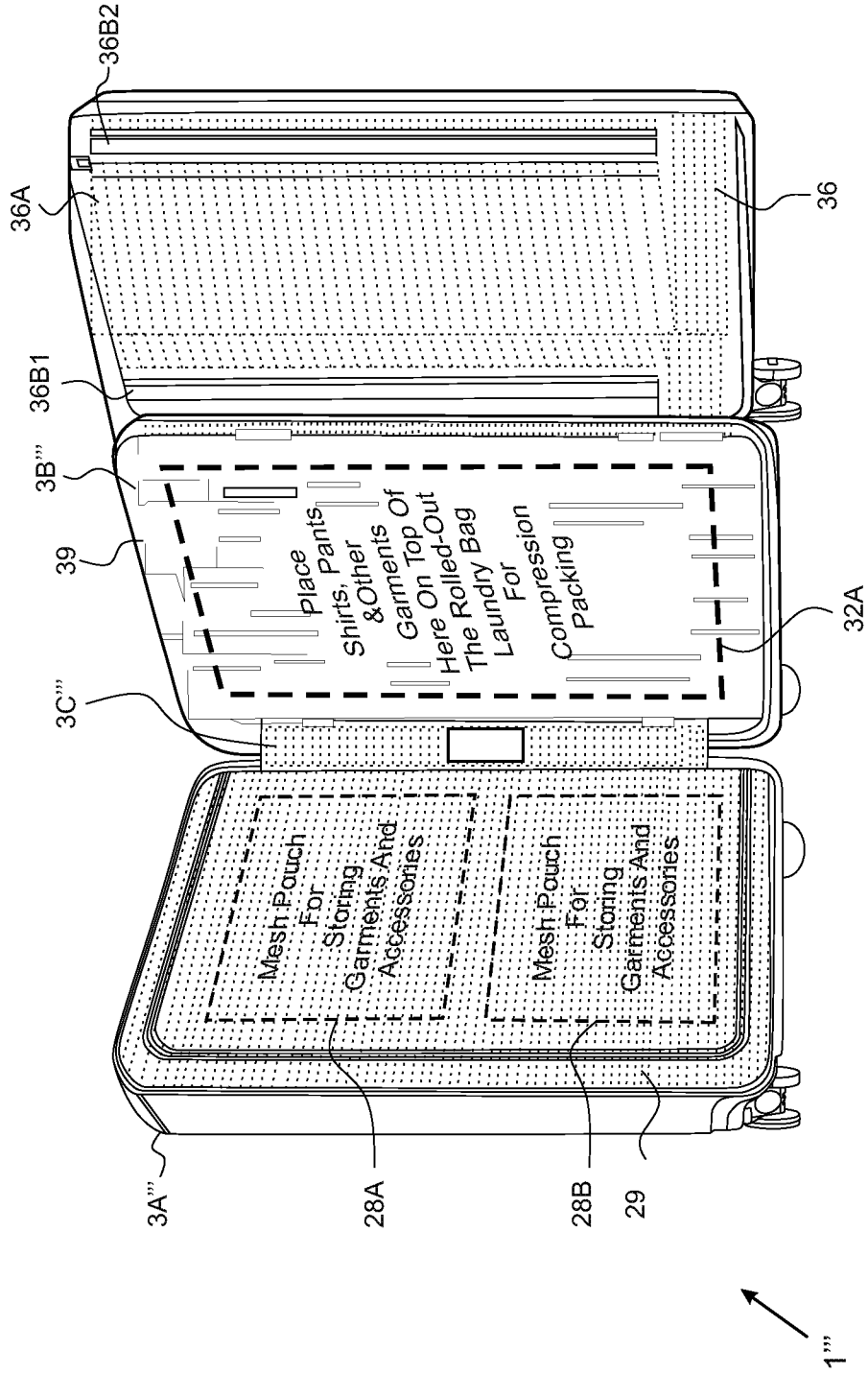

FIG. 15A2

2021240291 01 Oct 2021

77/103

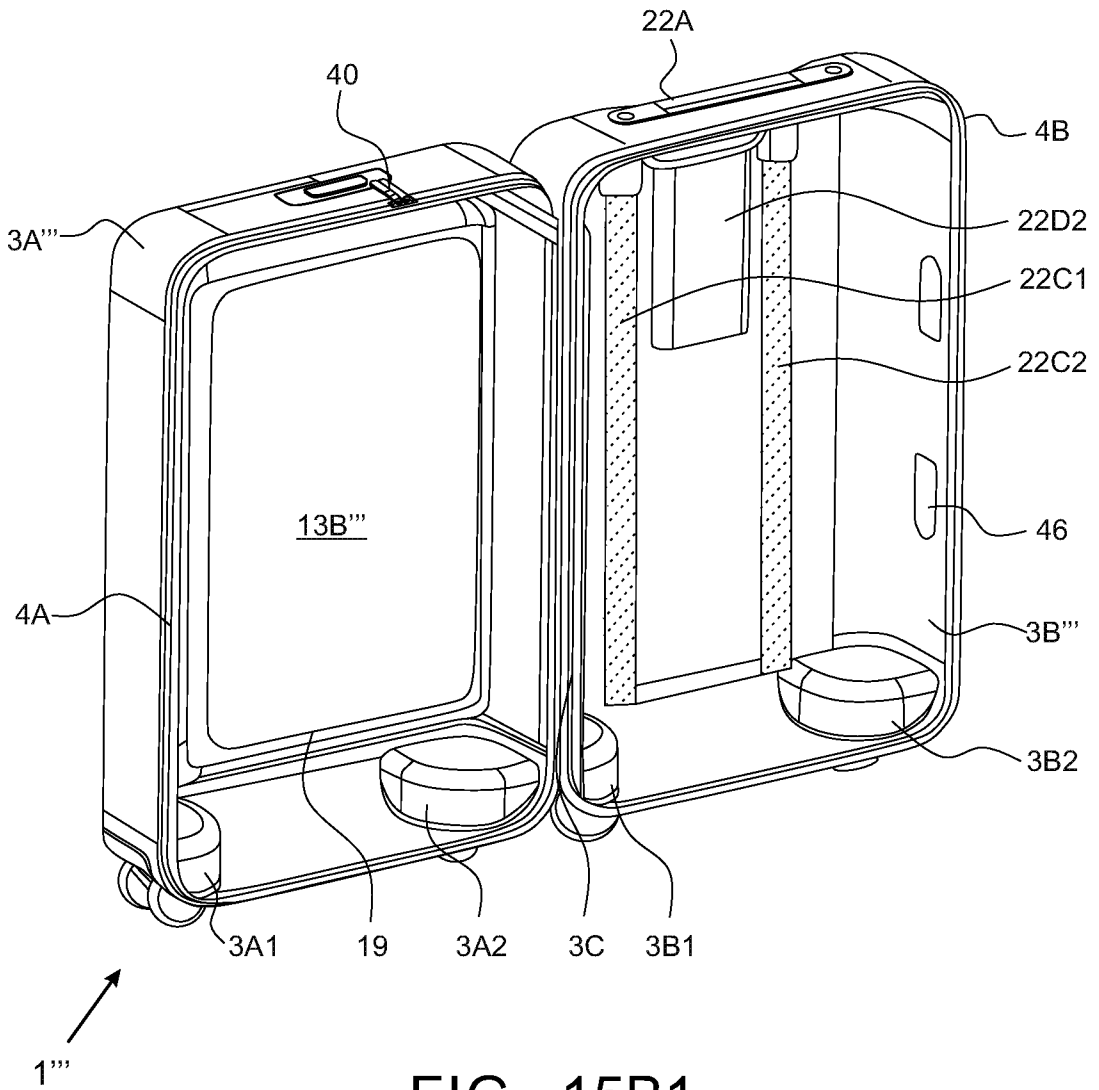

FIG. 15B1

2021240291 01 Oct 2021

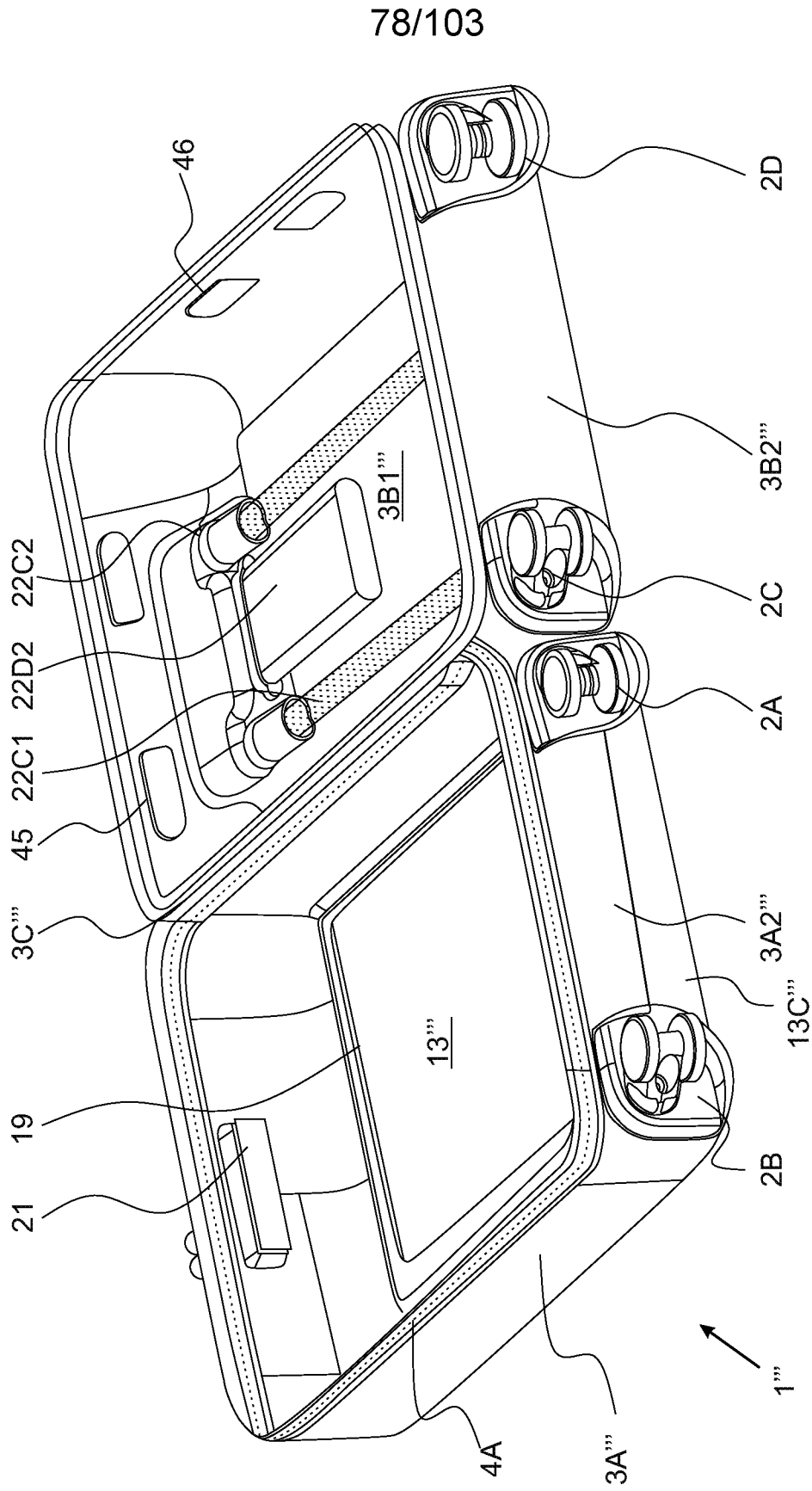

FIG. 15B2

2021240291 01 Oct 2021

79/103

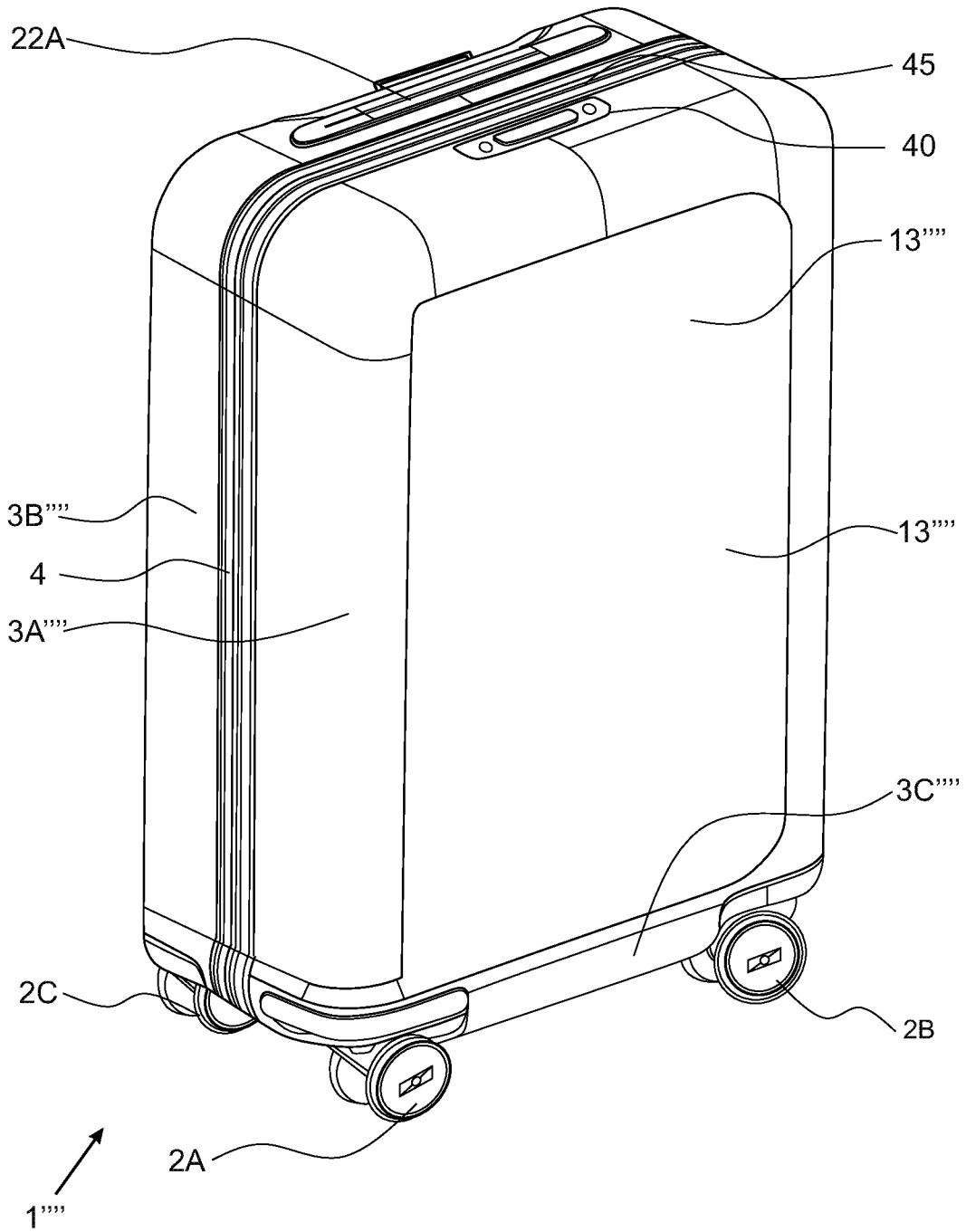

FIG. 16A

2021240291 01 Oct 2021

80/103

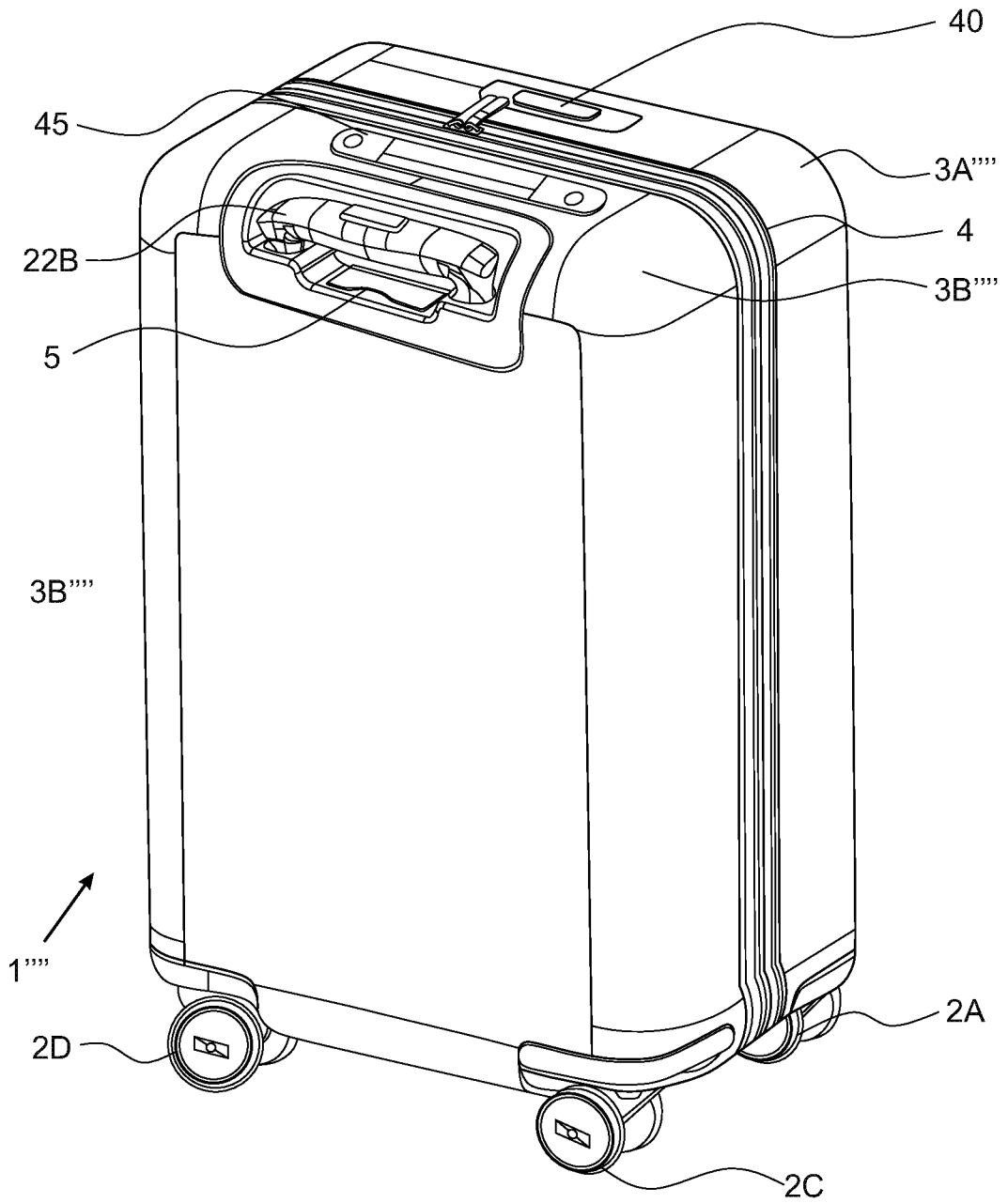

FIG. 16B

2021240291 01 Oct 2021

81/103

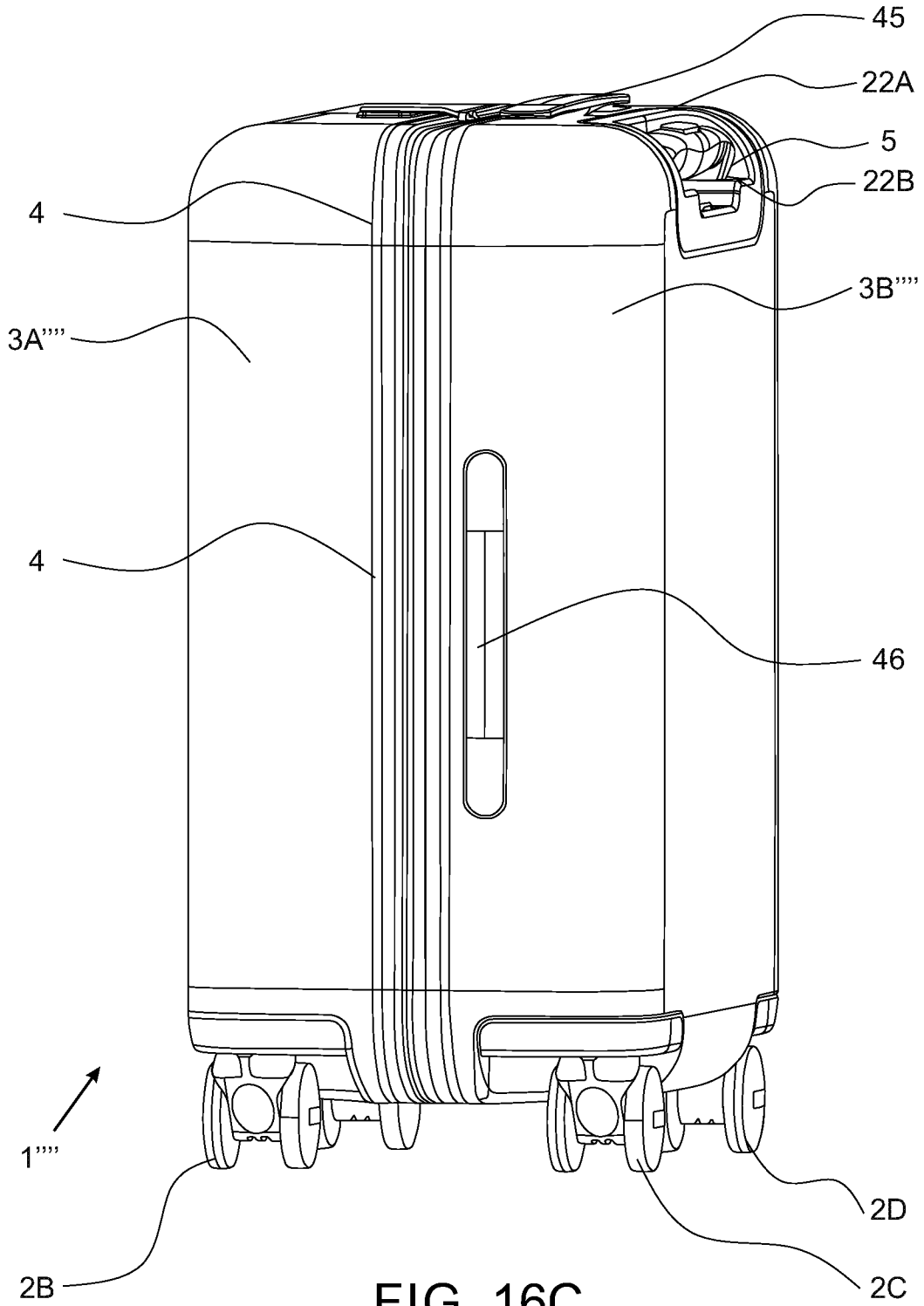

FIG. 16C

2021240291 01 Oct 2021

82/103

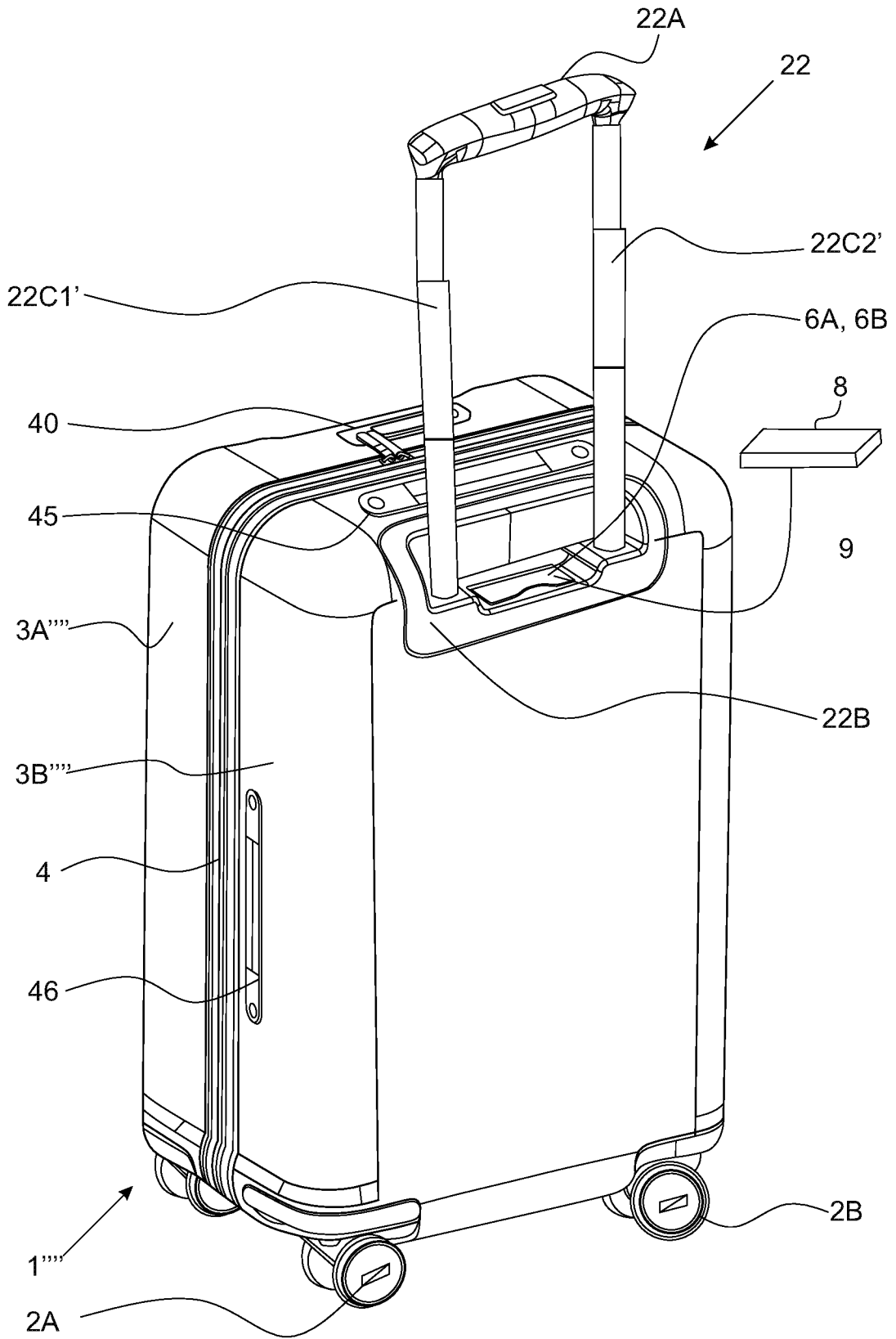

FIG. 16D

2021240291 01 Oct 2021

83/103

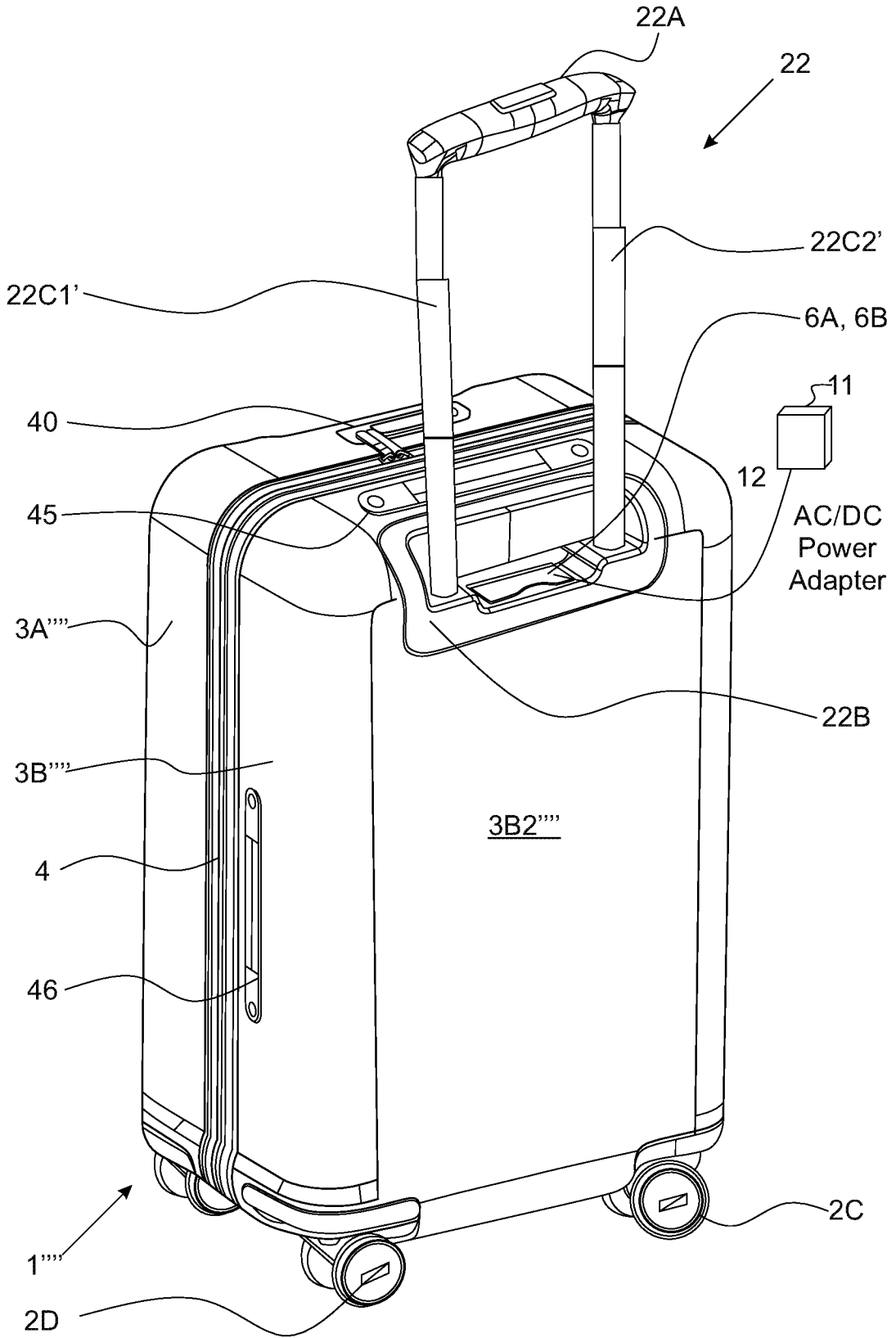

FIG. 16E

2021240291 01 Oct 2021

84/103

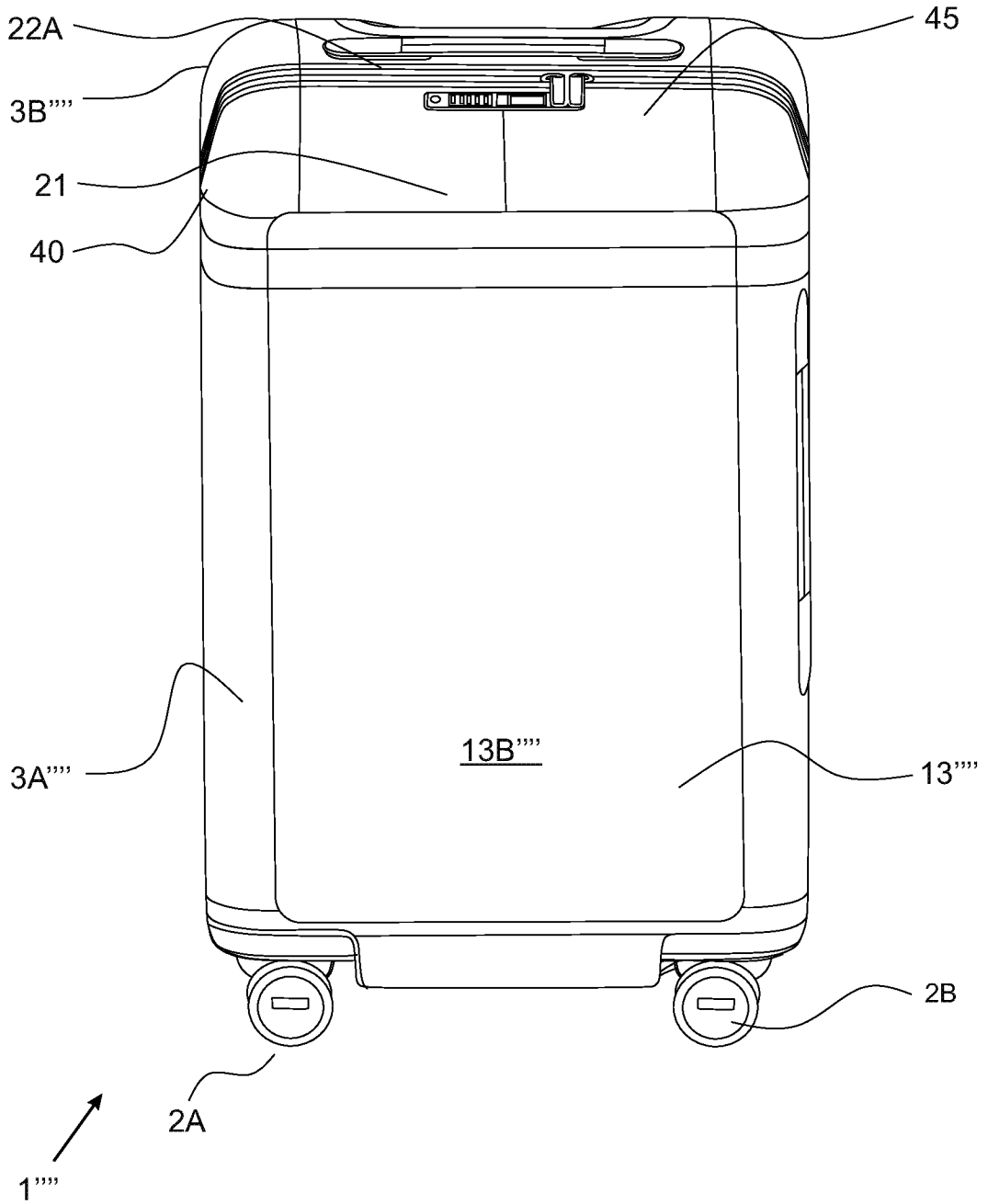

FIG. 16F

2021240291 01 Oct 2021

85/103

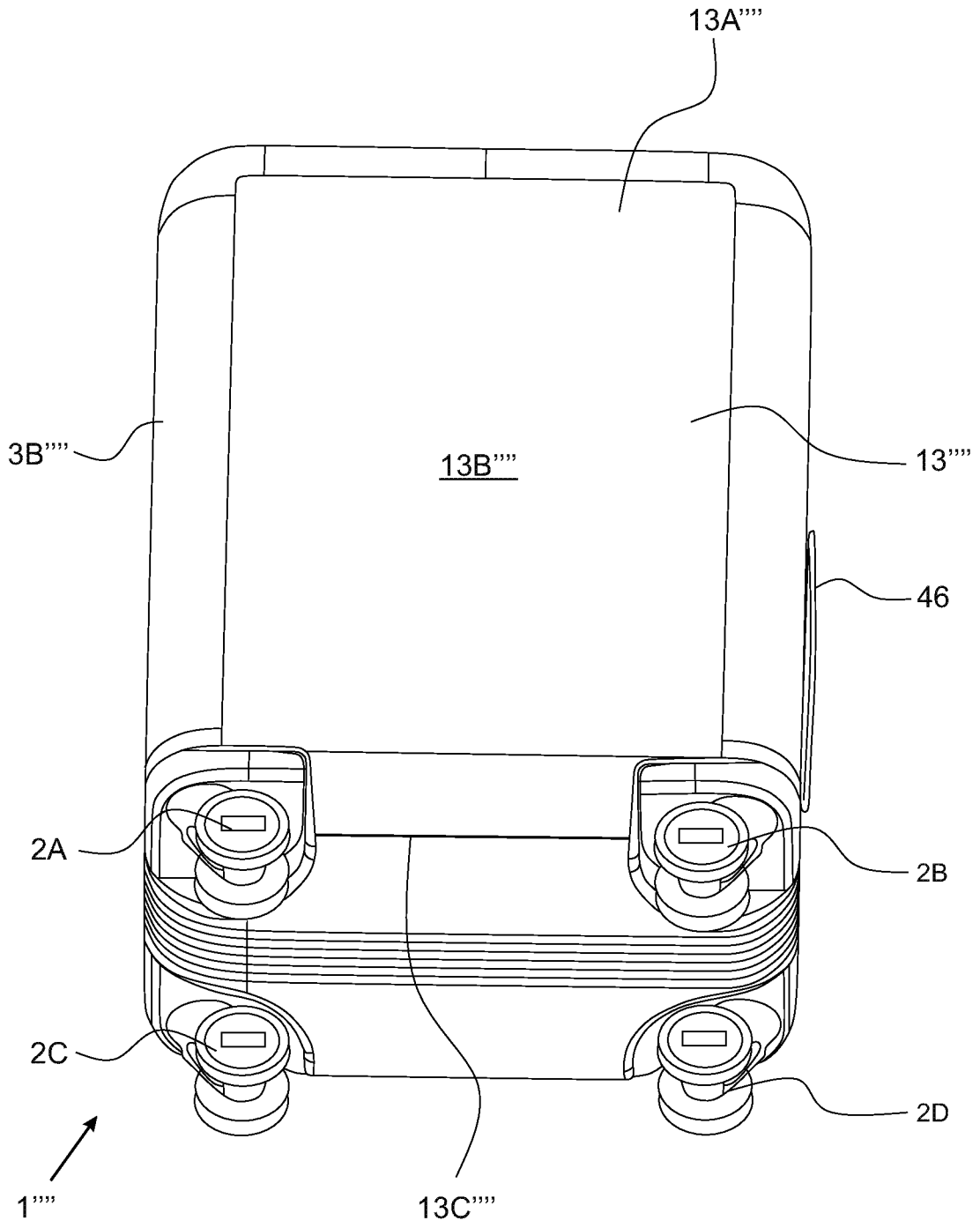

FIG. 16G

2021240291 01 Oct 2021

86/103

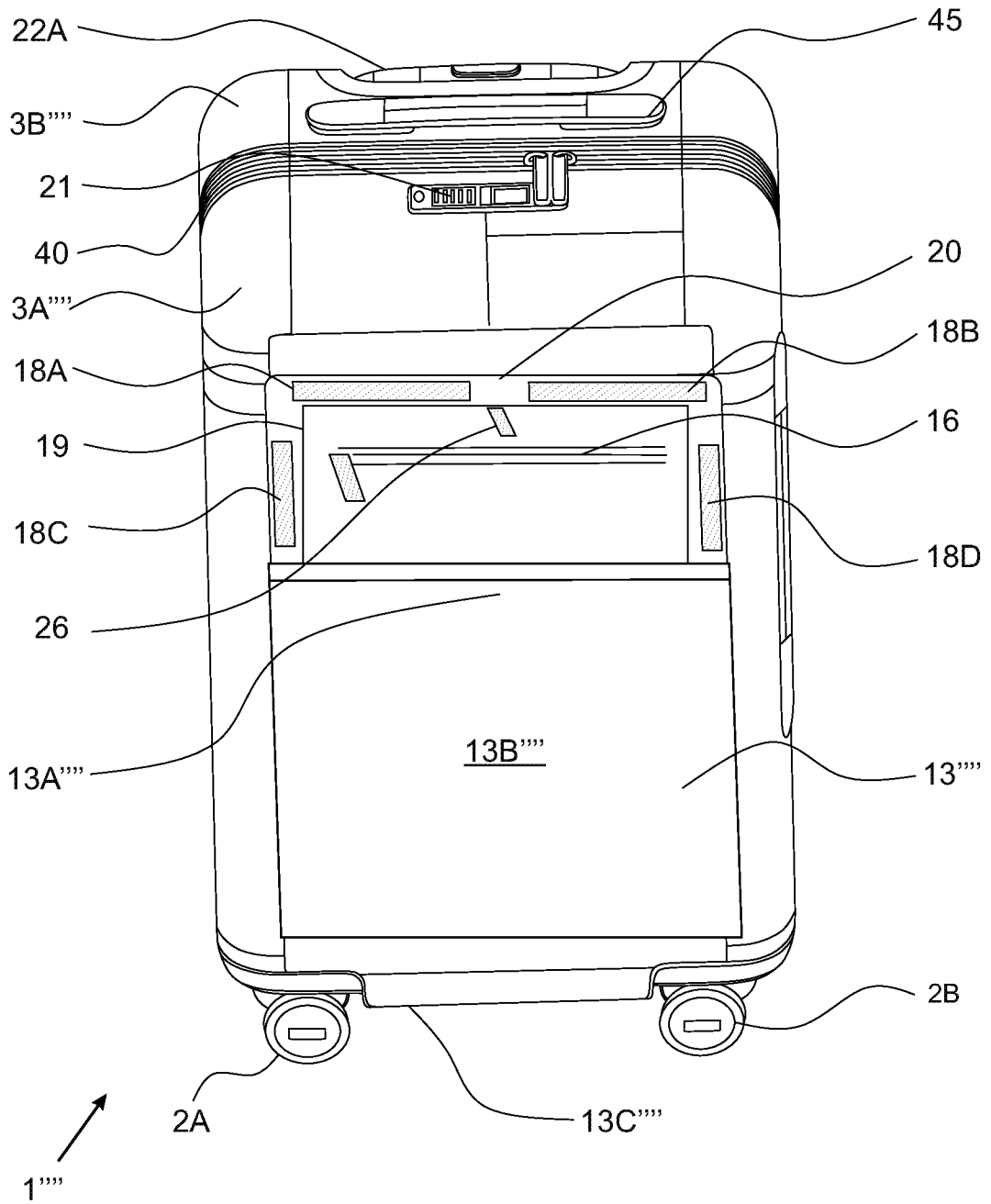

FIG. 16H

87/103

2021240291 01 Oct 2021

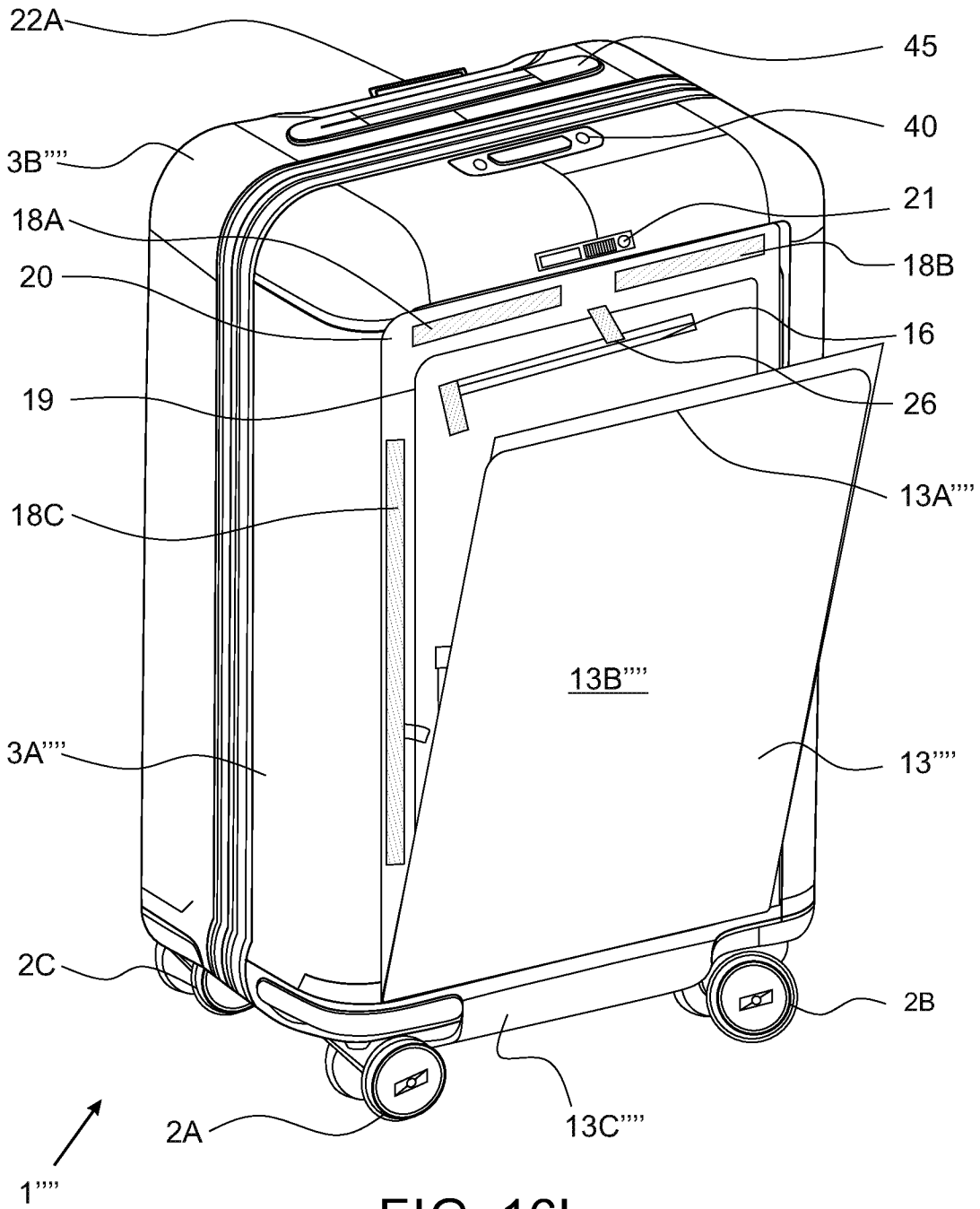

FIG. 16I

88/103

2021240291 01 Oct 2021

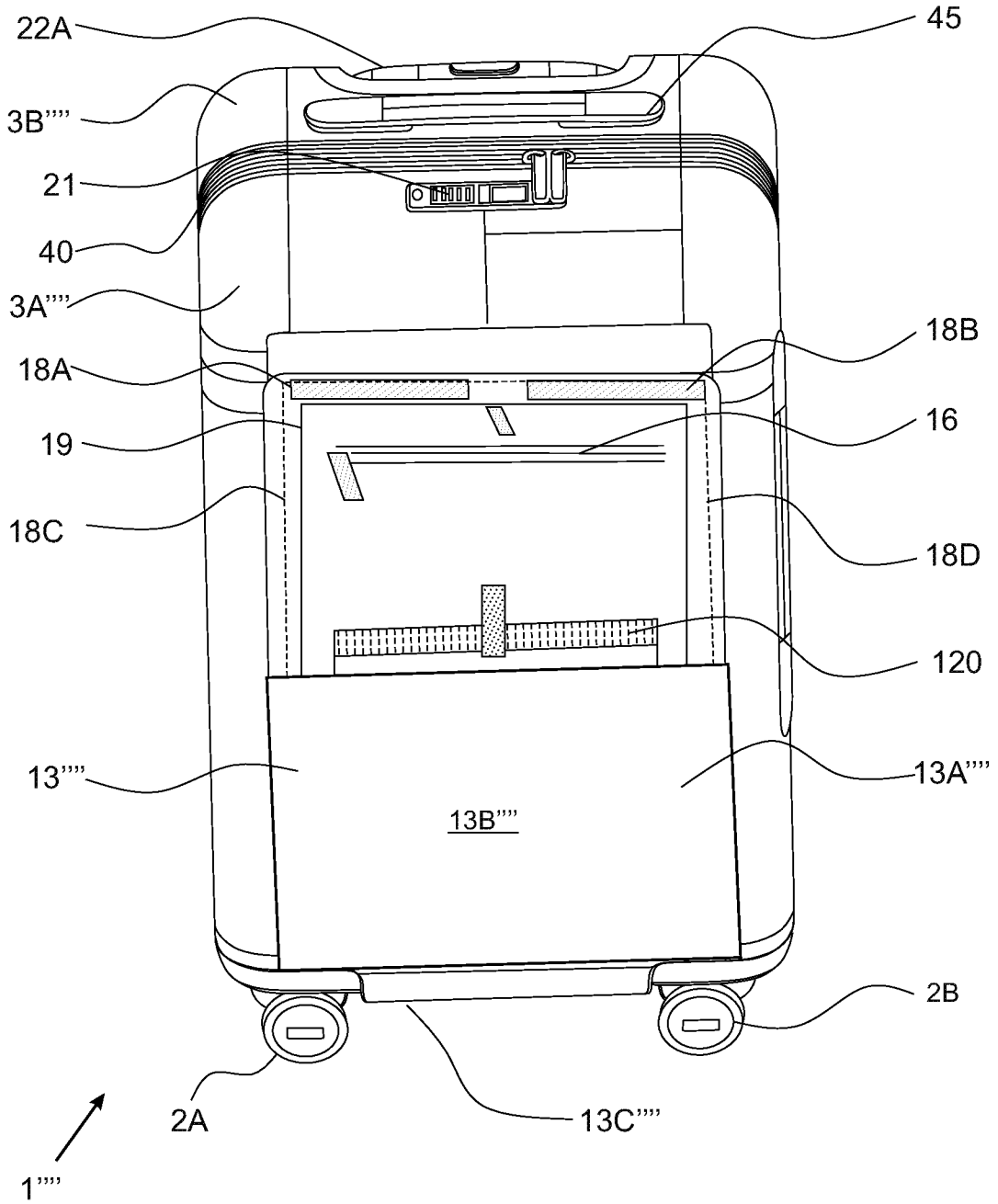

FIG. 16J

89/103

2021240291 01 Oct 2021

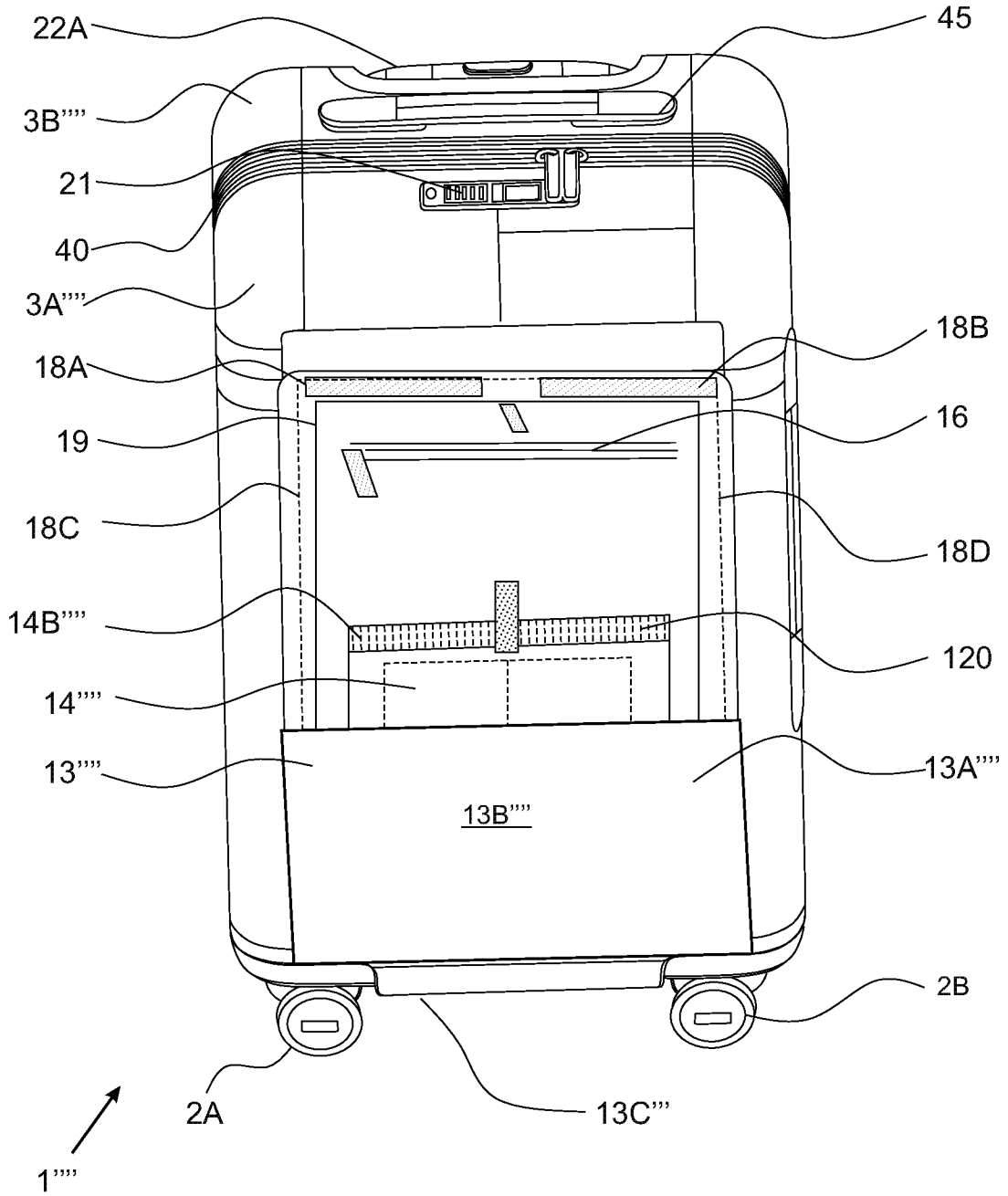

FIG. 16K1

2021240291 01 Oct 2021

91/103

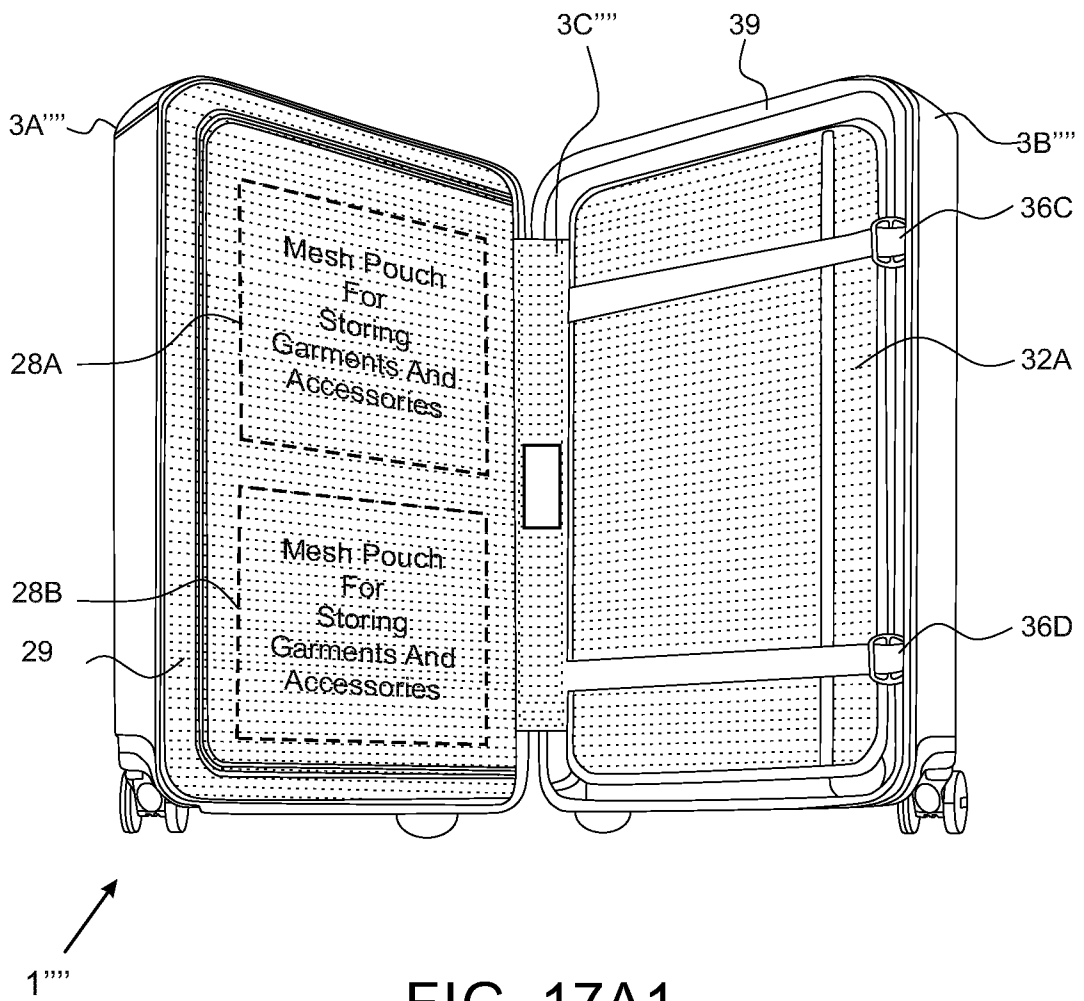

FIG. 17A1

2021240291 01 Oct 2021

92/103

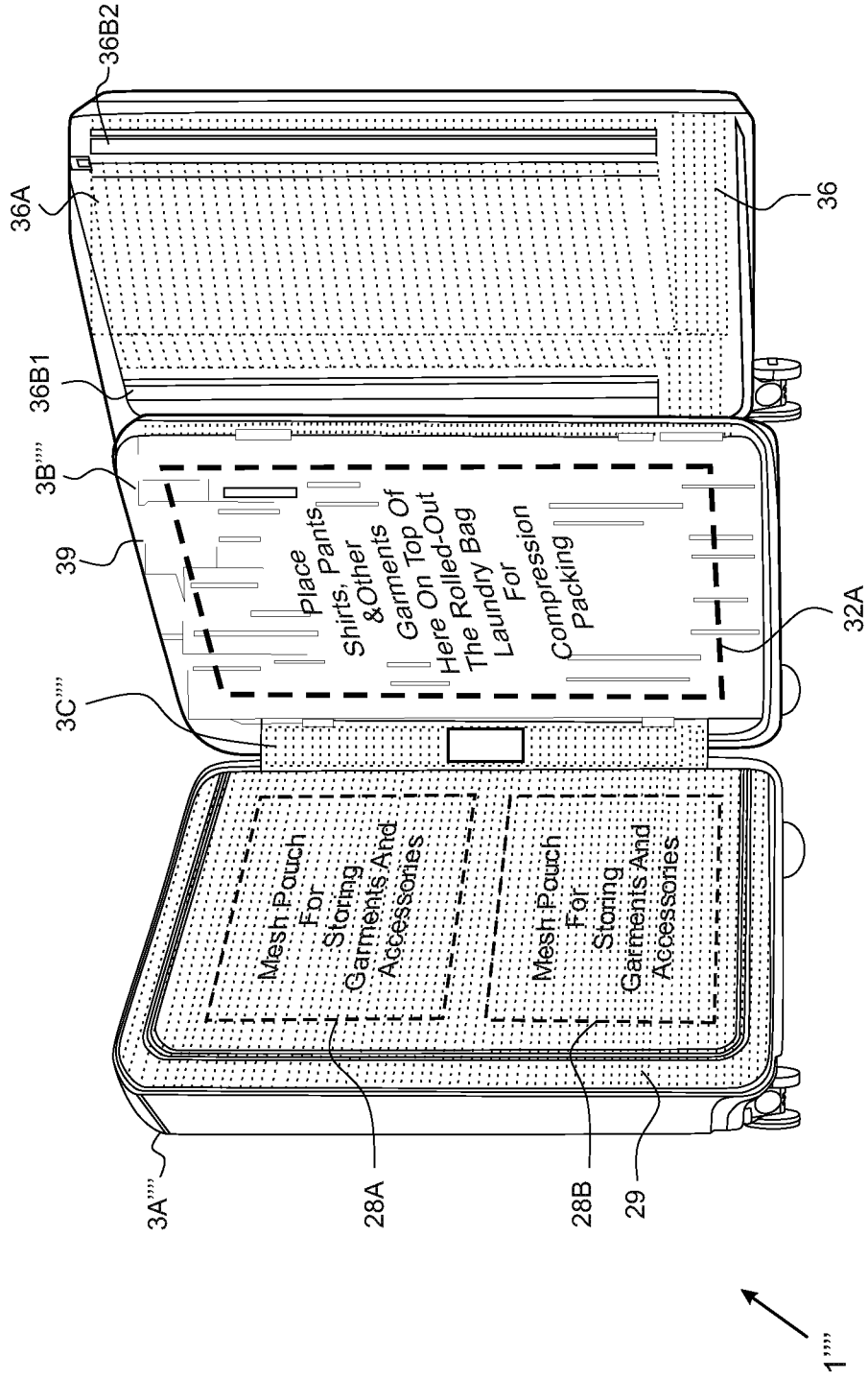
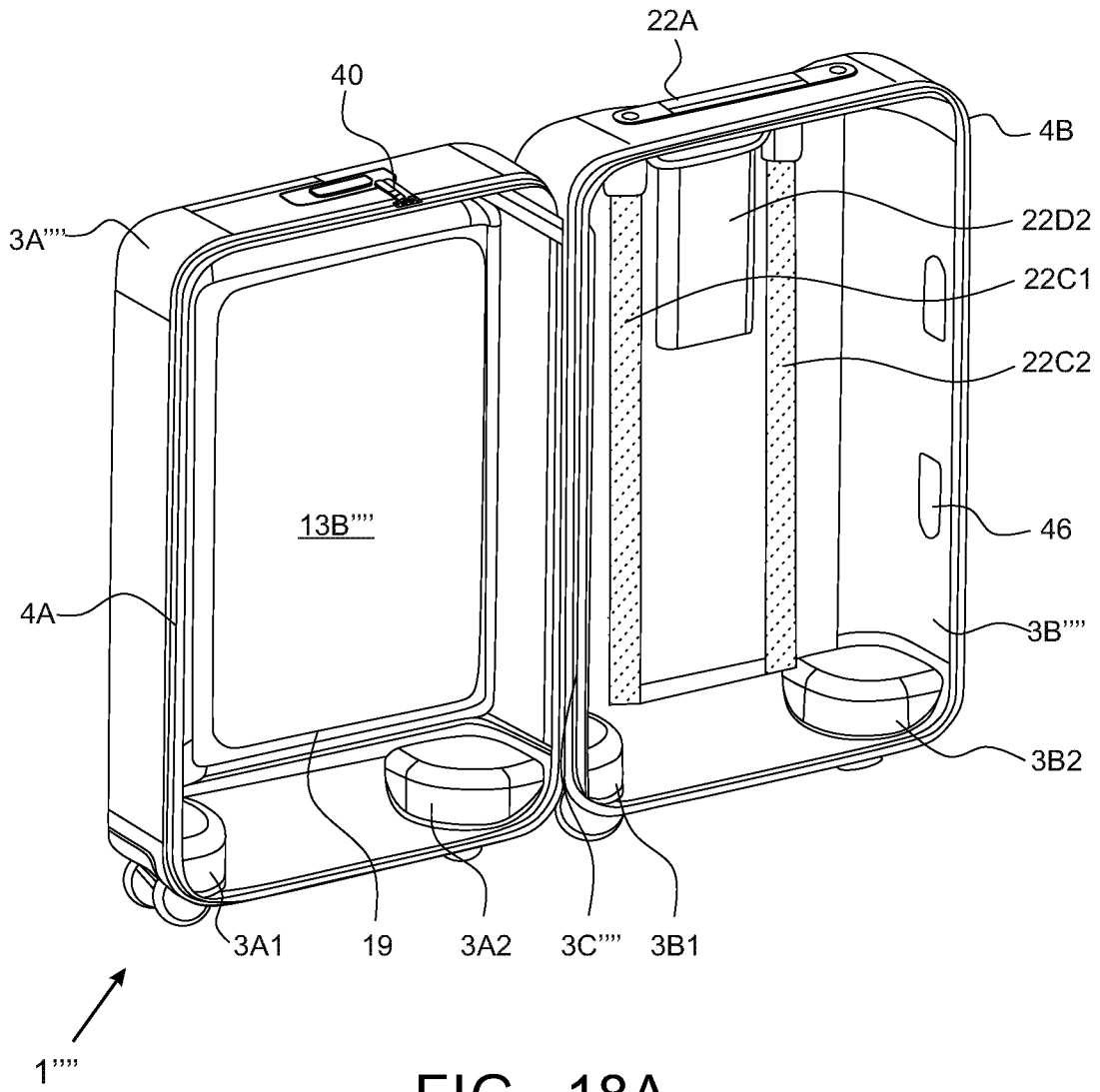

FIG. 17A2

2021240291 01 Oct 2021

93/103



2021240291 01 Oct 2021

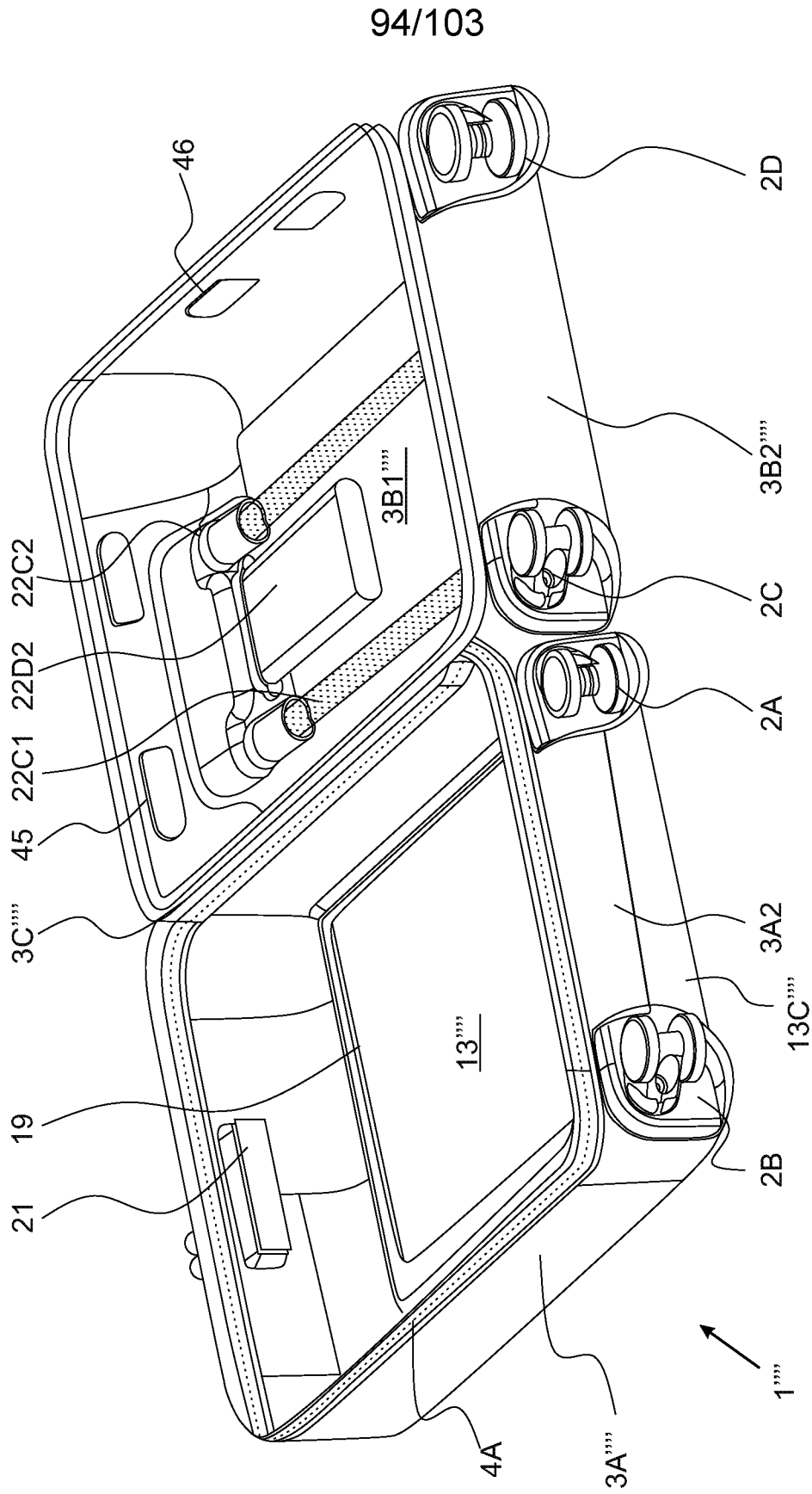

FIG. 18B

2021240291 01 Oct 2021

95/103

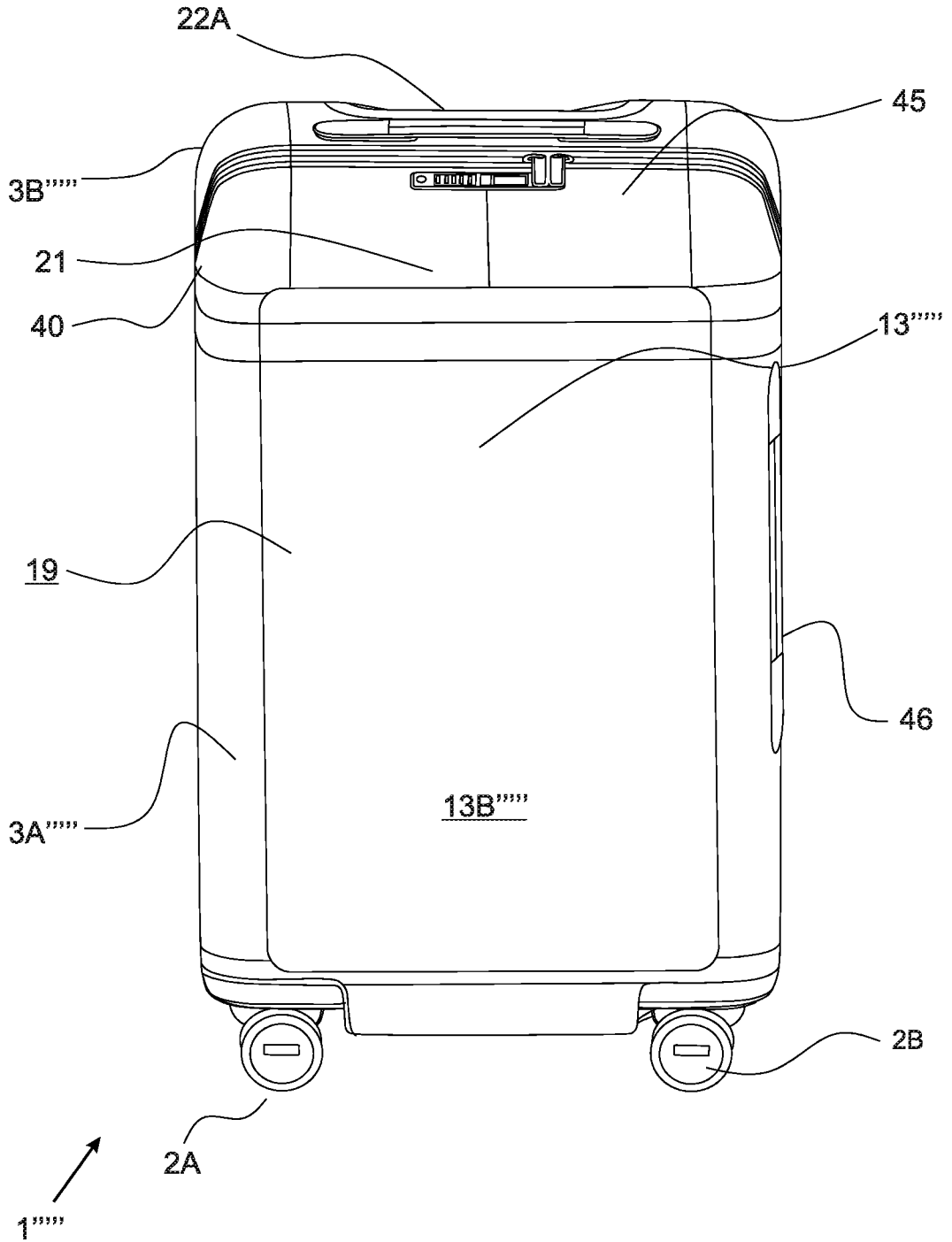

FIG. 19A

96/103

2021240291 01 Oct 2021

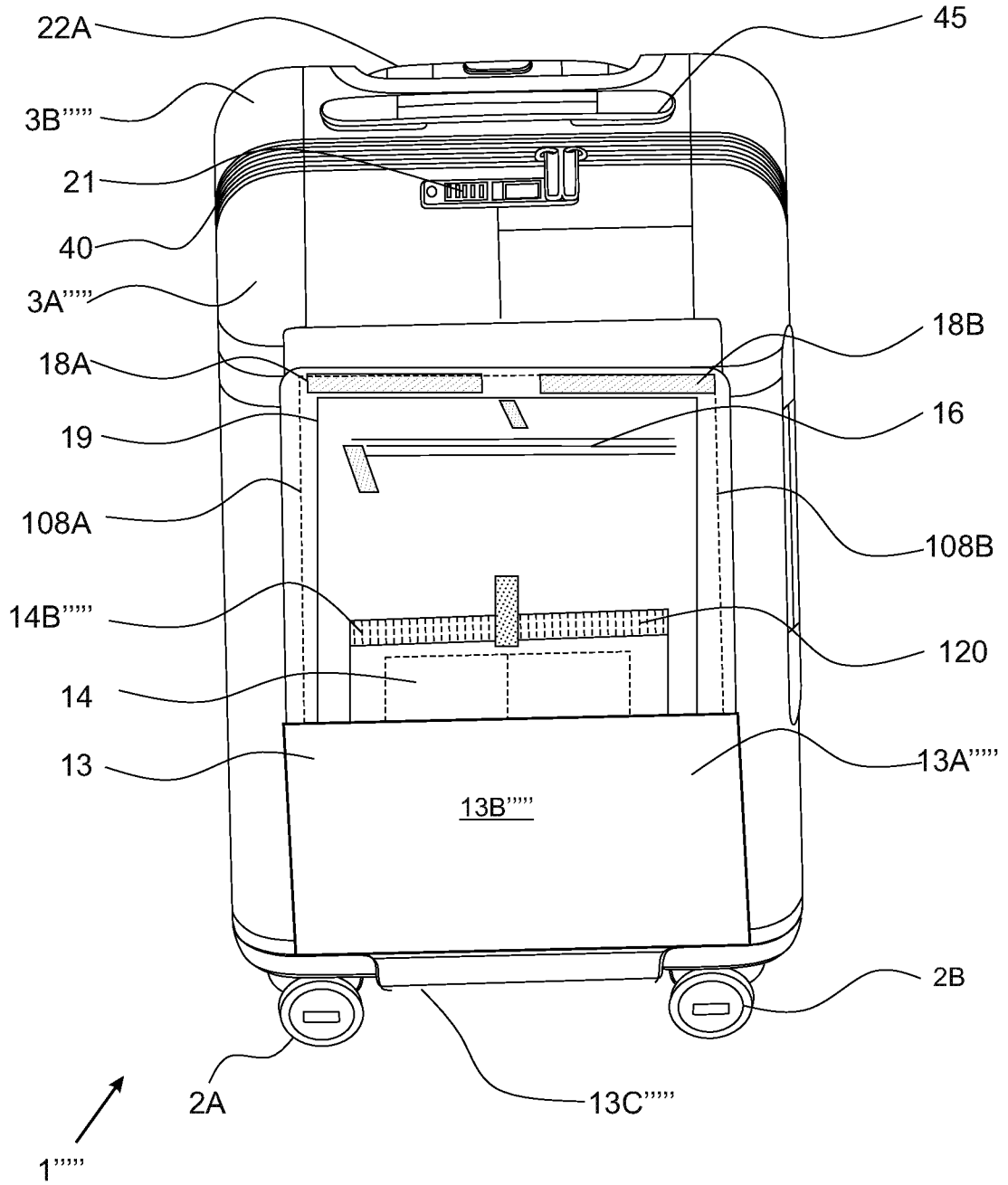

FIG. 19B

2021240291 01 Oct 2021

97/103

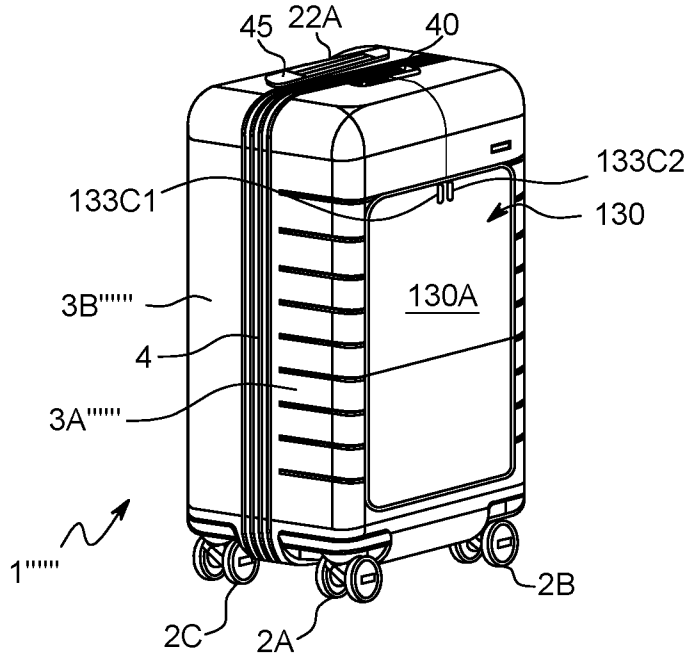

FIG. 20A

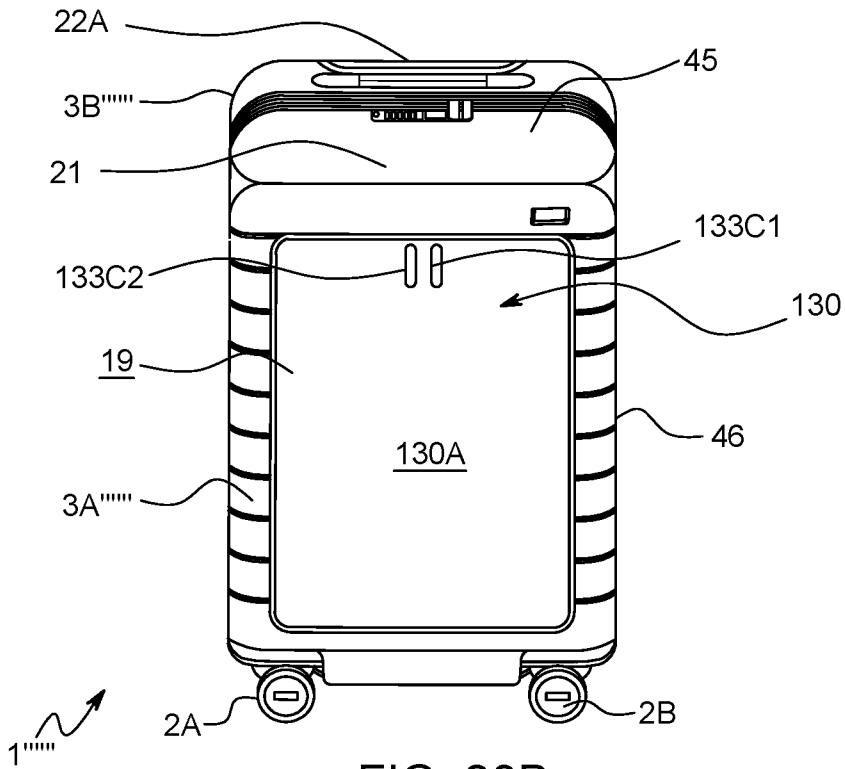

FIG. 20B

2021240291 01 Oct 2021

98/103

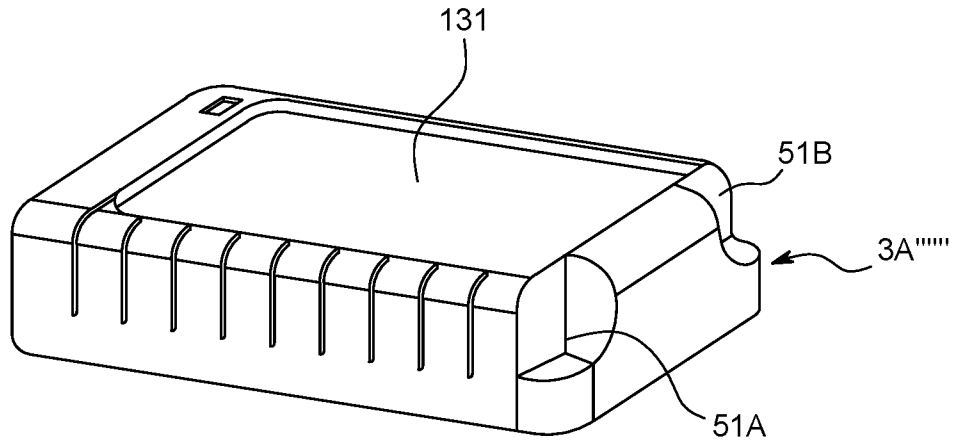

FIG. 20C

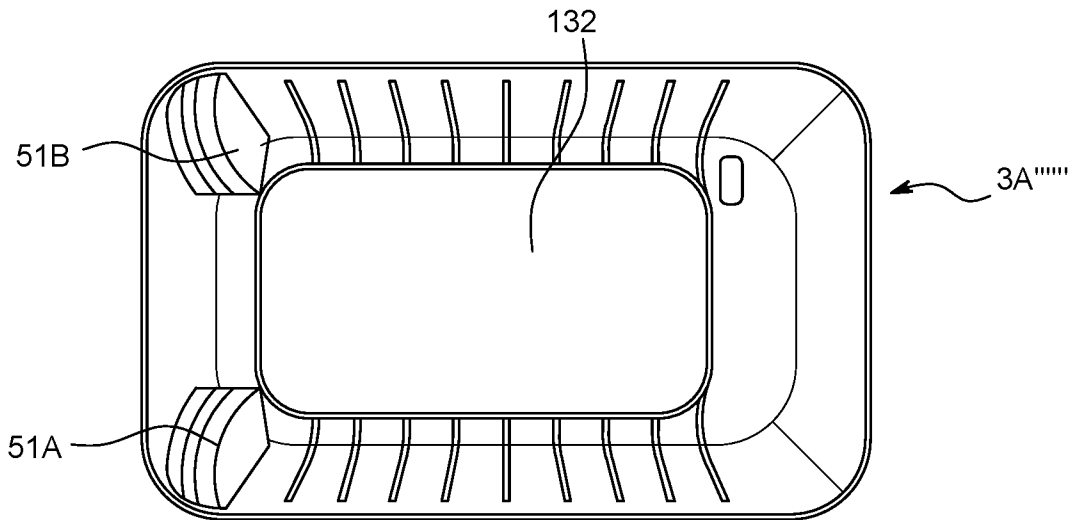

FIG. 20D

99/103

2021240291 01 Oct 2021

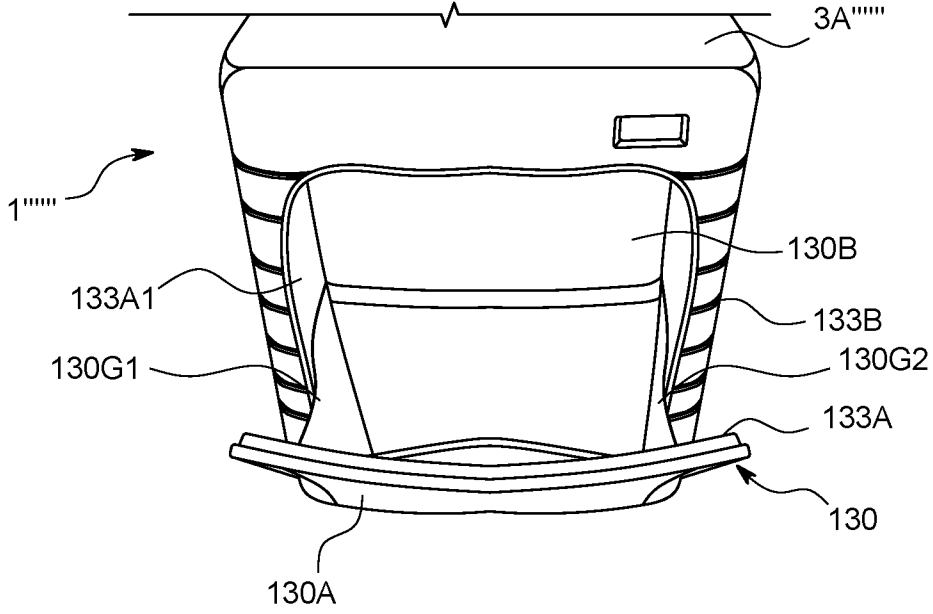

FIG. 20E

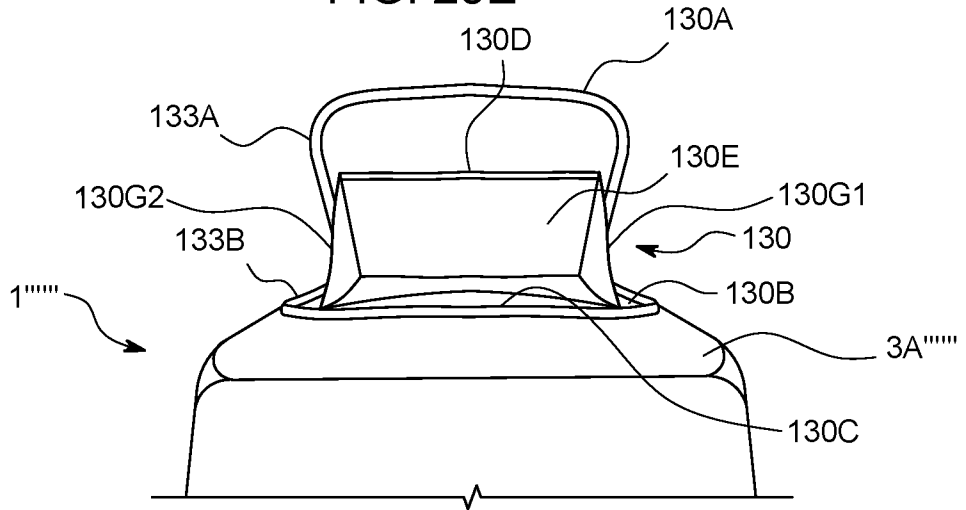

FIG. 20F

2021240291 01 Oct 2021

100/103

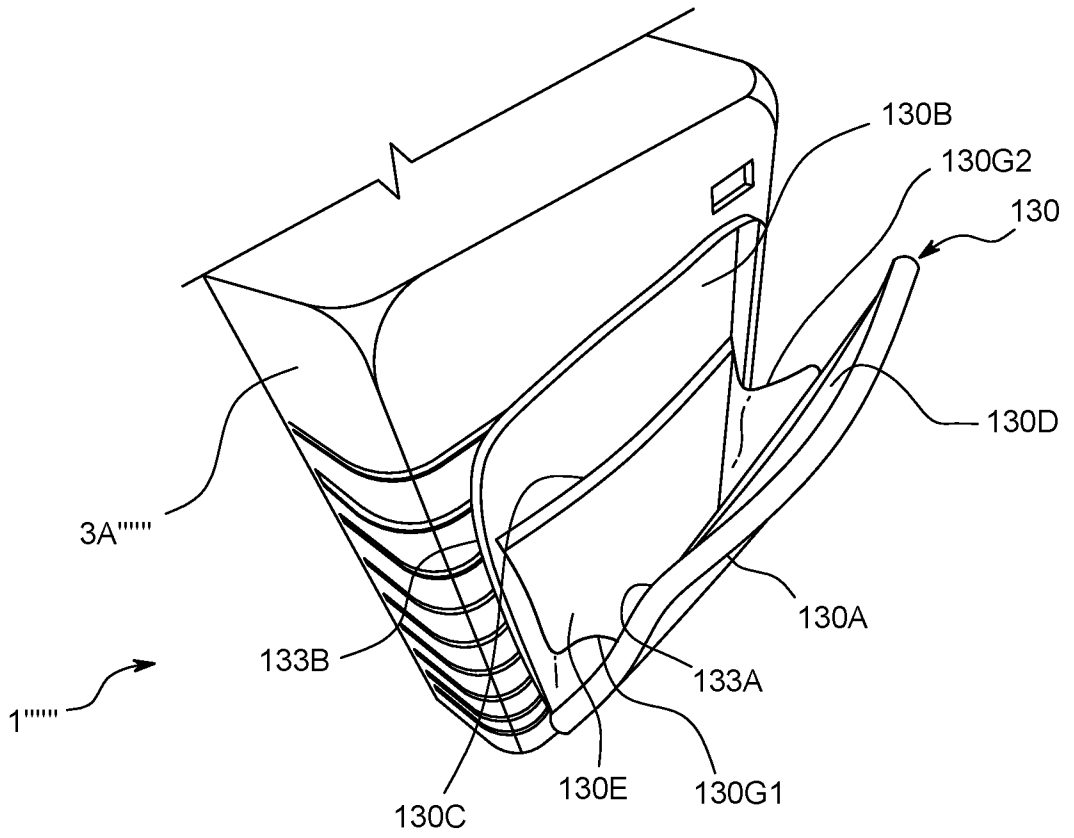

FIG. 20G

2021240291 01 Oct 2021

101/103

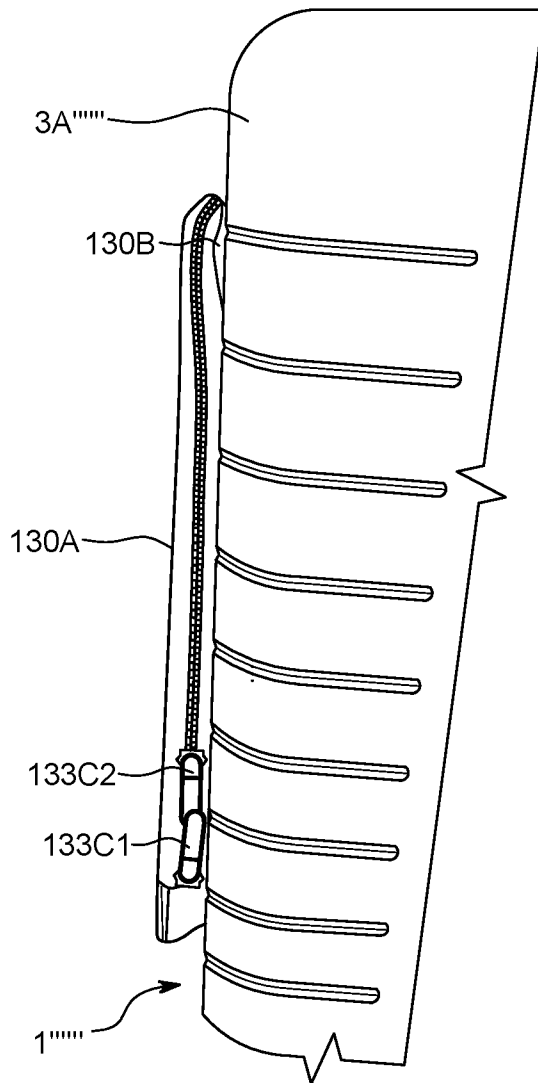

FIG. 20H

102/103

USB DC ELECTRICAL POWER SUPPLY SUBSYSTEM
INSTALLED ABOARD THE LUGGAGE SYSTEM

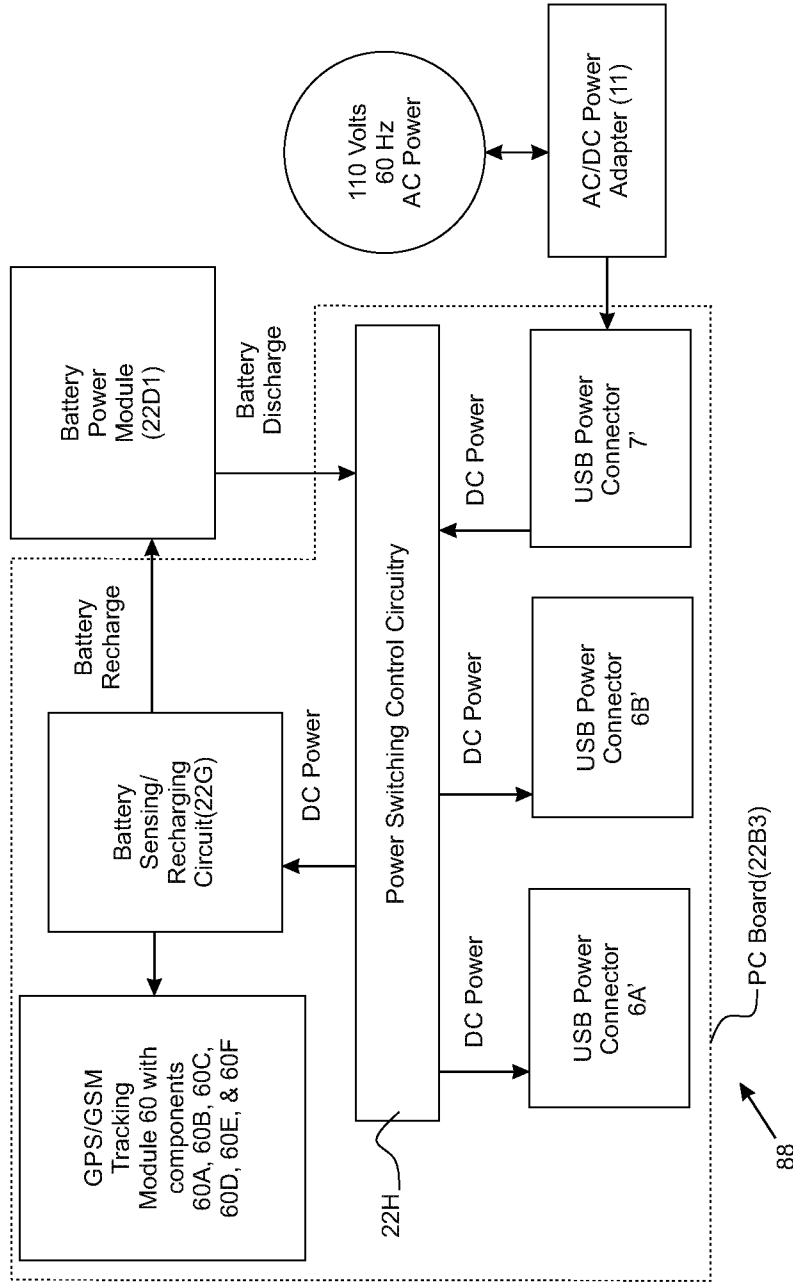

FIG. 21

GPS/GSM Luggage Location System

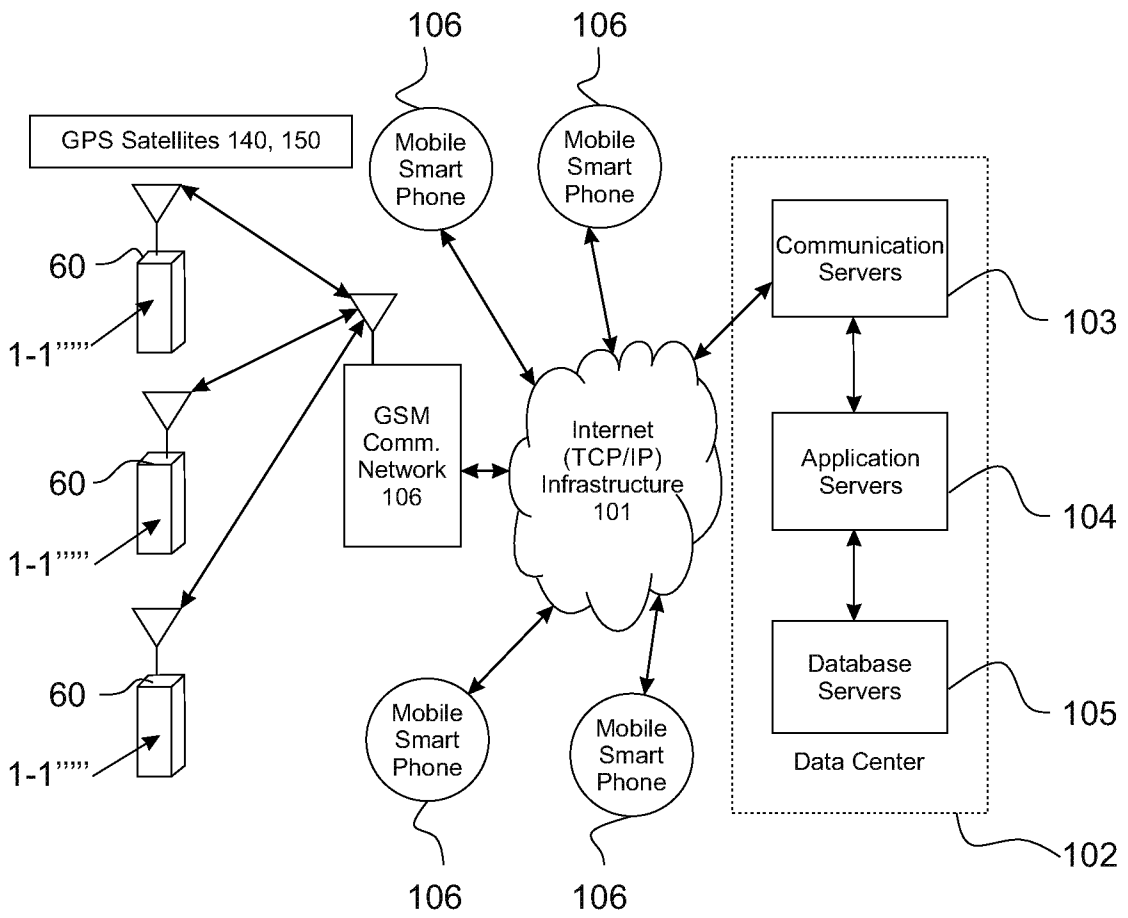

FIG. 22

2021240291 01 Oct 2021