

(1a) (8a) (7) (8a) 가 (7) 3 가 (1a) 3
 (1b) (8) (5) (1a) (8a) 3 (7) (8a)
 (1a) (8a) (8a) (1a) (8a)

1

3 , , , , , , ,

, , , , , , 3 3
 , 3

, , , , 3 (transit) , 2
 가 (光波距離計) , (三角測量) ,
 , 3

, 1 () 3 3
 「MONMOS」 , 2
 3 (鉛直角), 3 (視準) , 1
 00m ± 1mm , 3
 가 , 3 , , , , ,
 가

, 「MONMOS」 () (視準作業) 가 ,
 (視野) (寫出) 가 (光軸)

「TCA1100」 CCD (自動視準手段) 「CYBER MONMOS」가 (測角儀)

가 () 가 (teaching) 가

8 - 136218 9 - 14921 3

가

3 가 CCD 가

, 3 가 3 , 2 가

가

가 가

3 (造船)

가 (先) (가) 17 (中小) (大) (dock) 가

가 가

가 가 가 가 가 (bottle neck)

mm mm 가

% mm mm 가

가 가 3

가 1 3

3 3 3

1 (測角計) 3 3

가 3 가

3

2 (回動) 가

3 3 가

1 3

3 3

, 1 1 2 , 1 2
 3 , 1 n , n (n+1)
 , n 3 , (n+1) 가 n (n+1)
 (n+1) 가 , (n+1) 가 n (n+1)
 , n , n , , ,
 n 3 가 , 3 , ,
 , , , .

1 , 1 3 .
 2 , 1 3 .
 3 , TV .
 4 , TV .
 5 , 1 3 .
 6 , 1 가 .
 7 , 2 3 .
 8 , 7 3 .
 9 , 2 TV .
 10 , 2 TV .
 11 , 2 TV .
 12 , 2 3 .
 13 , 2 가 .

, 8 (7) , 3 , 14 3 , 7

2 가 (1) (7) (8a) (1a) (1a) (1a) (1b) (2) (3) 2 (7) 가 (6) , 3 (14) (8) (8) ()

, 25 - 100mm(50mm 가) (8a) (0.5 - 1.0mm) (8)

6) TV (4) , 1 (8a) 가 , 1.5° 가 , (8a) (6) (1a) T (4) (8) , (2, 3) (1a) (2, 3) (8)

, 1 TV TV (5) (7) (8) (5) (6)

(6) , TV (5) (8a) (1a) (7) TV (5) (5) (8a) (1a) (1a) (6) (8a) (1a) (2, 3) (1a) (8a) , TV (4) 1 (8a) (1a) (1a) (8a) (8) (1a) (1a) (8a) 3 (1b)

(7) TV (5) (8) (1a) (8a) , 3 , TV (5) (1a) (1a) d , (5) (5)

8a) (1a) (8a) , TV (5) 가 TV (5) ()
 , (5) 가 .

3 (1a) , (8a) , (1a) L, w
 (1a) , TV (5) , 1 2 .

1
 $\tan(\theta) = w / L$

2
 $\tan(\theta) = (w - d) / L$

, 1, 2 , 3 .

3
 $= \tan^{-1} [\tan(\theta) + d / L]$

, 3 L TV (5) , 가 가 , (8a) L1, 가
 , 4 (8a) L2 L0 3 (1a) 가 가 , 4 .

(8a) (7) L1 L2 , 4
 , TV (4) (13)가 ,
 (8a) L0 , 5, 6 7, 8 .

4
 $= \tan^{-1} [\tan(\theta) + d / L0]$

5
 $1 = \tan^{-1} [\tan(\theta) + d / L1]$

6
 $2 = \tan^{-1} [\tan(\theta) + d / L2]$

7
 $\tan(\theta) - \tan(\theta_2) = \tan(\theta_2 + \theta) - \tan(\theta_2) = d(1 / L0 - 1 / L2)$

8

$$\tan(\theta_1) - \tan(\theta_2) = \tan(\theta_1) - \tan(\theta_1 + \theta_2) = d(1/L_1 - 1/L_0)$$

(7) , L1 = 10m, L2 = 30m , (1a) TV (5)
 d 150mm , , 1, 2가 가 1 = 0.43° , 2 =
 0.15° 가 , TV (4) , 1.5° ,
 , 가 .

, L1, L2, d , TV (5) (8a)
 (1a) (8a) , TV (4)
 (8a) , (8a) (1a) 가 .

5 , 3 , TV
 (5) , (7) (8a) 가 3 .

(8a) , TV (5) (8a) TV (5)
 (1a) (8a) , (1a) TV (5)
 (左上) (右下) , (6)
 (2, 3) , (1a) (8) , TV T
 V (4) (8a) 가 , TV
 (4) (8) , (1a) (8) .

(1a) (8) , (1a) (8a) , (1b)
 (1a) (8a) 3 , . 1
 (8a) , (8a) , (8a)

, (7) (8a) TV (5)
 1 , (8a) , (2)
 (3) (1a) (8a) 1 ,

, (1a) (8) , (1a) (1b) (8a)
 , (8a) 3 , (7) 가
 (8a) (7)

2

7 , 2 3 , 8 7 3
 (21) . , 1 2 ,

2가 TV (4) 1, 2 TV (5a, 5b) , ,
 TV (5a, 5b) , (7) TV (5a, 5b)가 ,
 , TV (5a, 5b) (6) , 1 가 ,
 TV (5a, 5b) (8a) ,

(7) , 2 TV (5a, 5b) (8a) (1a) , (1a)

TV (4) 1 (8a) , (8)
 , (1a) (8a) , (1b)
 , (8a) 3

(7) 2 TV (5a, 5b) (8)
 (1a) (8a) 9, 10 ,
 9 (1a), 2 TV (5a, 5b), (8a) 10
 (1a), 2 TV (5a, 5b), (8)(8a)
 2 TV (5a, 5b) , (1a) , d1, d2
 , , h , 2 TV (5a, 5b) , (2,
 3) TV (5a, 5b) (8a) TV (5a, 5b) , (8a) L

L , (1a) , 2 TV (5a, 5b)
 , , 9, 10

9

$$L [\tan(\theta) - \tan(\theta')] = d1$$

10

$$L [\tan(\theta) - \tan(\theta')] = d2$$

9, 10 , 11

11

$$= \tan^{-1} \{ [d1 \tan(\theta) + d2 \tan(\theta')] / (d1 + d2) \}$$

, (1a) , 12

12
 $= \tan^{-1} [\tan(\theta) + h / L]$

(1a) (8a) , 1 (6) (8a) (2, 3) TV (4)

TV (5a, 5b) (1a) (1a) d (5a, 5b)
 (2,3) , 11 , 2 TV

(1a) (8a) 가 , 2 TV (5a, 5b)
 (8a) , 2 TV (5a, 5b)
 가 .

11 (1a) (8a) , 2 TV (1a) (5a, 5b) L, w , , 13,
 14, 15 .

13
 $\tan(\theta) = w / L$

14
 $\tan(\theta) = (w - d) / L$

15
 $\tan(\theta) = (w + d) / L$

13, 14, 15 , 16 .
 , 17 .

16
 $= \tan^{-1} \{ [\tan(\theta) + \tan(\theta)] / 2 \}$

17
 $=$

TV (5a, 5b) (8a) = ,
 (6) (2,3) (1a) (8a)
 (8a) TV (4) .
 , TV (5a, 5b) (8a) .
 TV (5a, 5b) (8a) .
 (8a) TV (4) 가 , 2 TV
 (5a, 5b) (7) 가 30m , 10m , TV (4) 가 , 가 가
 TV (5a, 5b) 가 가

512 x 480 , 0.14 ° , TV (4) , 1.
5 ° , , 가 .

, TV (5a, 5b) 2 , (7) 가 ,
(8a) 가 , TV (4) , 가

TV (5a, 5b) 2 , (1a)
, 가 , 1 , (1a)

12 , 3 , TV
(5a, 5b) , (7) (8a) 가 , 3

, 2 TV (5a, 5b) (8a) , TV (5a, 5b)
(8a) (1a)
5b) , (8a) , 2 TV (5a,
(2,3) , (2,3) (6) (8a)
TV (4) (8a) 가 , TV
(4) (8a) , (1a) (8) .

(1a) (8) , (1a) (8a) , (1a)
1b) (1a) (8a) 3 , (8a) . 1
(8a) , (8a) , (8a)

(7) (8a) , 2 T
V (5a, 5b) 2 , (8a) (2)
TV (3) , (1a) (8a) 1 ,
TV (4) .

, 1 가 , , TV (4)
(1a) (8) , (1) (8a)
3 , (7) (8a) (7)

, TV (5a, 5b) 2 , (7) 가 ,
(8a) 가, 10 - 30m 5 - 50m (8a) ,
TV (4) 가 , ,
TV (4) , 가 .

3

14 , 3

1 2 3 , 3
 , 17
 14 , , , 3 (31)
 15 , .
 가 , (31) ,
 , CAD ,
 , 가 , ,
 (31) 가 , ,
 , (32) , .
 16 , , 가 .
 14 16 , (8) ,
 , 가 ()가 (32) ,
 , , 가 .
 , 가 ,
 , CAD , , 가 CAD
 , (32) ,
 (32) , 가 , (6) , (31) , (32)가 ,
 , 가 , 1 2 .
 , , () ,
 , , 가 () ,
 , 가 .

(7)가

(1a)
a, 5b)

가 2

TV (5, 5a, 5b)
(8)

PSD (8)

TV (5, 5)
(8)

TV (5, 5a, 5b)

가 (7)

(2,3)

TV (5, 5a, 5b) (2,3)

(7)

TV (5, 5a, 5b)
(8a) 가

(6)

(1a)

TV (5, 5a, 5b)

6 13

가 (total station) (10)

(6)

(10)

CPU(12) (command)

(57)

1.

3

3

3

가

가

3

2.

1

3

3

3.

1 ,

,
3

, 1

4.

3 ,

2

3

5.

4 ,

, 2

2

3

3

6.

5 ,

(立體視)

3

7.

가

1

1

3

1

가

1

3

3

8.

, 2 가 ,

, , , , ,

, 3

1 가

, , , , , , , , ,

3 , 3 .

9.

8 , 3 , -

- - , 3 .

10.

8 , , 1 , 3 .

11.

10 , 2 3

12.

11 ,

, 3 , 3

13.

8 ,

, 3 ,

3 . ,

14.

8 ,

2 ,

3 .

15.

14 ,

, 3 , 1

16.

11 ,

2 ,

3 .

17.

16 ,

, , 2 가 3 1 .

18.

3 3 , ,

, 3

가 , 3

19.

$\frac{1}{3}$, $\frac{1}{1}$, $\frac{2}{n}$, $\frac{1}{(n+1)}$, $\frac{2}{3}$,
 n , n , 3 ,
 가 n , $(n+1)$, $(n+1)$ 가 , $(n+1)$,
 n , 3 , n ,
 가 , 3

20.

19 , , , 1

21.

19 , , ,

22.

1 , ,

3 , , 3 가

3 가 , 3

23.

22 , , 1

24.

22 , , ,

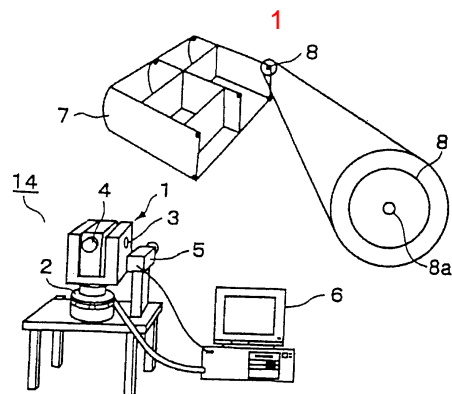

2

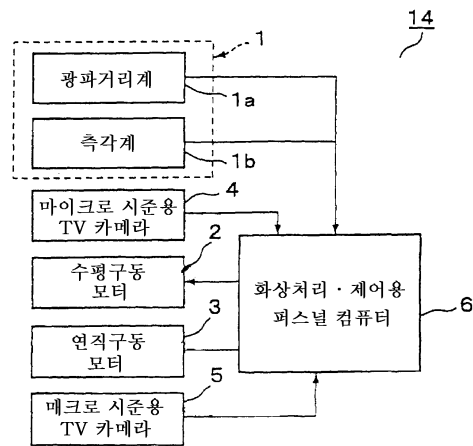

3

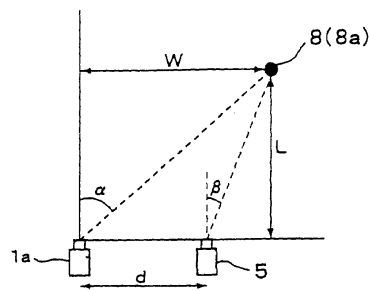

4

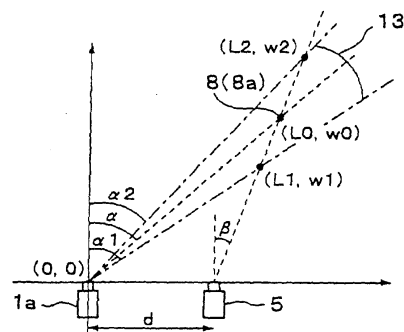

5

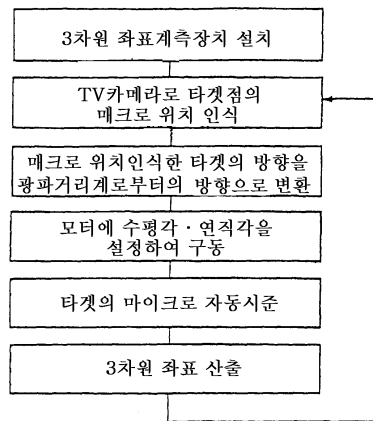

6

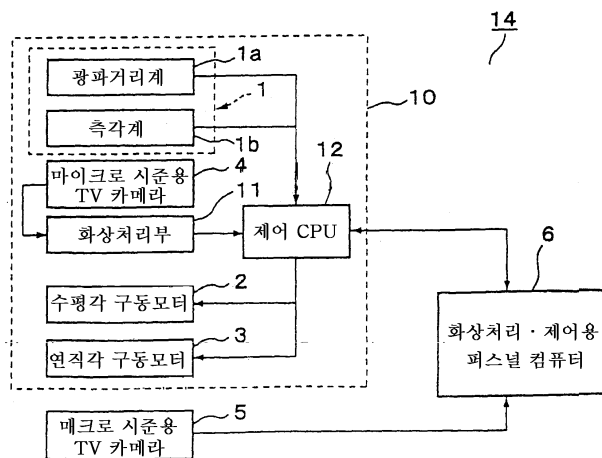

7

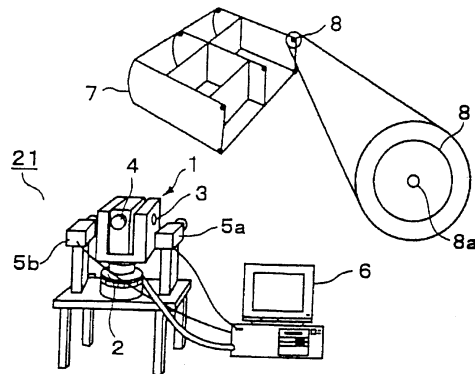

8

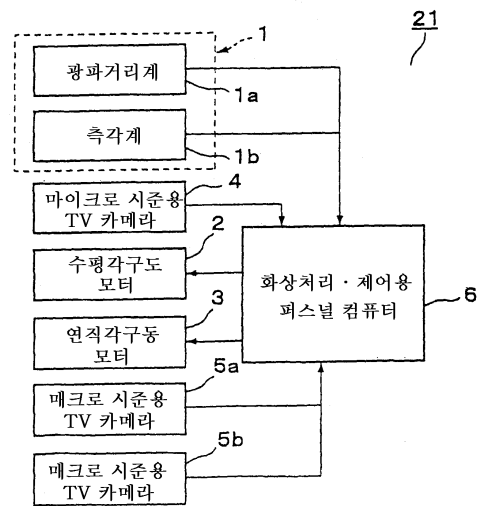

9

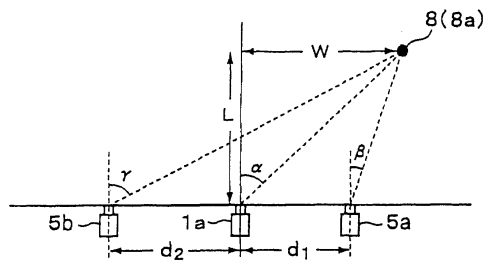

10

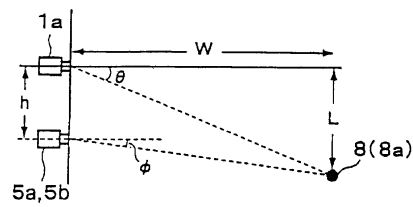

11

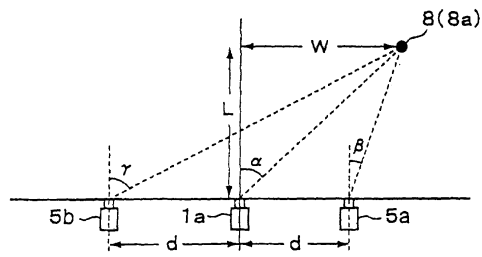

12

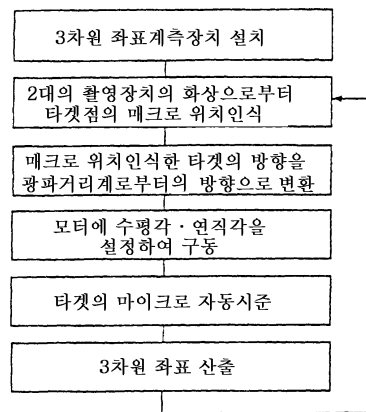

13

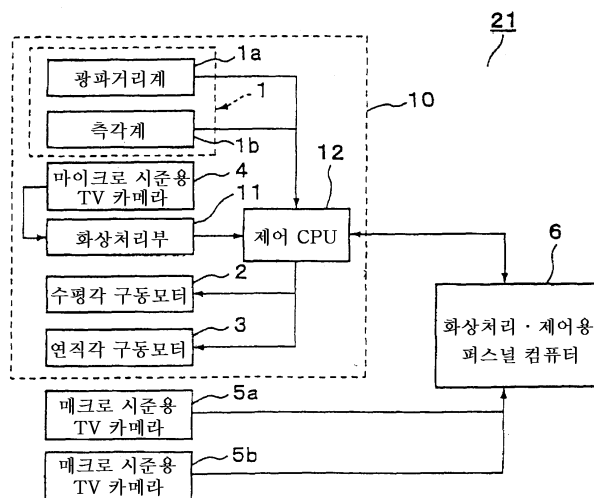

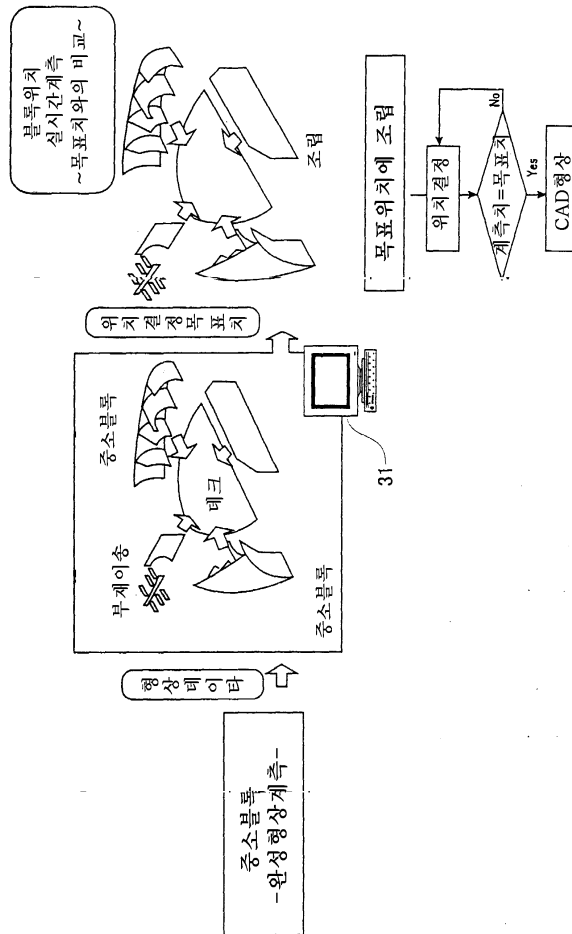

15

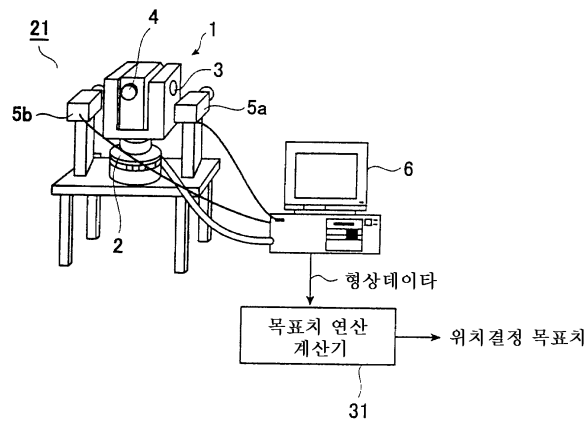
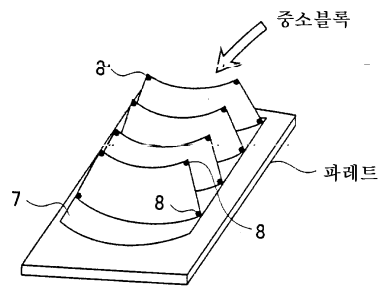

16

