

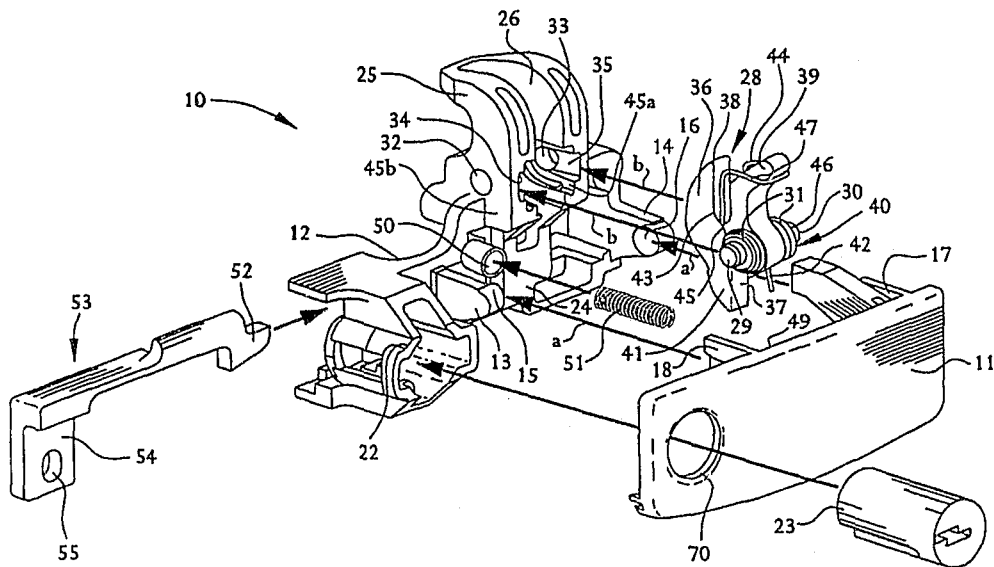

<p>(51) International Patent Classification ⁶ : E05C 3/16</p>	<p>A1</p>	<p>(11) International Publication Number: WO 99/13189 (43) International Publication Date: 18 March 1999 (18.03.99)</p>
<p>(21) International Application Number: PCT/US98/18990 (22) International Filing Date: 10 September 1998 (10.09.98) (30) Priority Data: 08/928,266 12 September 1997 (12.09.97) US 09/050,806 30 March 1998 (30.03.98) US (71) Applicant: SOUTHCO, INC. [US/US]; 210 North Brinton Lake Road, Concordville, PA 19331 (US). (72) Inventors: ANTONUCCI, Jeffrey, L.; 7 Bearcroft Avenue, Great Meadow, Warndon, Worcester WR4 0DR (GB). ULISSE, Ralph, C.; Apartment P-305, 620 Ronald Avenue, Glassboro, NJ 08028 (US). PINKOW, Christopher, J.; 151 South Bishop Avenue, Secane, PA 19018 (US). (74) Agents: BONINI, Frank, J., Jr. et al.; Paul & Paul, 2900 Two Thousand Market Street, Philadelphia, PA 19103 (US).</p>		<p>(81) Designated States: AT, AU, BR, CA, CH, CN, CZ, DE, DK, ES, FI, GB, HU, ID, IL, JP, KR, LU, MX, NO, NZ, PL, PT, RU, SE, SG, SI, TR, UA, European patent (AT, BE, CH, CY, DE, DK, ES, FI, FR, GB, GR, IE, IT, LU, MC, NL, PT, SE). Published With international search report.</p>

(54) Title: RATCHETING PAWL LATCH



(57) Abstract

A pawl latch assembly (10) with a spring locking member (53) having its own internal spring force for enabling a force from a handle (11) of the assembly to be transmitted to a pawl (28) to engage or disengage a keeper member (100) for opening and closing of the latch, and further having a lock (23) for securing the latch against unauthorized opening.

5

RATCHETING PAWL LATCHBACKGROUND OF THE INVENTION1. Field of Invention

10 The present invention relates to the field of latch assemblies.

2. Brief Description of the Prior Art

Latch assemblies are relied on in many applications for securing items, such as panels, together. For example, 15 containers, cabinets, closets, compartments and the like may be secured with a latch. An important use for latches is in the automotive field, where there is a desire and need to access automotive compartments, such as, for example, the trunk or passenger compartments of vehicles, as well as 20 interior compartments such as a glove box.

Various latches for panel closures have been employed where one of the panels such as a swinging door or the like is to be fastened or secured to a stationary panel or compartment body. The prior art devices generally utilize a 25 locking member which is spring loaded externally by one or more separately provided torsion springs. For example, some prior art devices rely upon a lock which comprises rigid metal parts and requires additional biasing members for operation of the assembly.

30

SUMMARY OF THE INVENTION

The present invention relates to a latching system for securing two panels together such as those of storage structures in which an enclosure is secured by means of a 35 door or panel which will remain in a closed position until released. An example of a use of the present latching system is in connection with automobile glove boxes or other compartments which are to be secured for storage of items therein.

40 The present invention provides a novel ratcheting pawl latch assembly with a spring locking member which provides

the locking member with its own internal spring force when the locking member is deflected by an actuating lever. The actuating lever can be provided in the form of a handle or paddle. The spring locking member enables a force from a handle of the latch assembly to be transmitted to a pawl which selectively engages and disengages a keeper member. When the keeper member engages the pawl, the pawl is rotated until the locking member slips in behind it. The pawl is provided with a torsional spring member which causes a force load from the spring member to be supplied to the pawl.

When the paddle is rotated or swingably moved away from the panel surface to which it is attached, the spring locking member is engaged and is lowered and retracted out of the way of the pawl. The pawl is disengaged from the keeper with the actuation of the paddle, which causes the spring locking member to release from its engagement with the pawl, whereupon the torsional pawl spring member which provides a force load to the pawl, releases its force load to return the pawl to its unlocked position away from engagement with the keeper. The keeper wire is thereby disengaged and the paddle or handle is reset with a spring loading mechanism to its original position.

The present invention also provides a locking mechanism in which a key can selectively lock and unlock the latch assembly. In addition, the present invention also provides a means whereby the handle or paddle can be offset from the pawl and locking member. This offers greater flexibility for selecting a location for the latch and for greater alternative placements when utilizing this latch as described herein.

It is a principal object of the present invention to provide a novel latch assembly which is selectively engageable with a keeper member, and includes a spring locking member which is spring-loaded with its own spring force for engaging and releasing a pawl from a keeper member when a handle is actuated.

It is another object of the present invention to

provide a locking member which is comprised of spring steel or plastic.

Another object of the present invention is to provide a lock which can be operated by a key or other operator, such as radio, infrared, electronic or other means, which
5 selectively engages the locking member against movement.

BRIEF DESCRIPTION OF THE DRAWINGS

Fig. 1 is a right front perspective view of a
10 ratcheting pawl latch according to the present invention showing the latch housing with the pawl and handle in exploded view therefrom.

Fig. 2 is a rear perspective view of the latch assembly of Fig. 1 shown in the open position.

15 Fig. 3 is a left side elevation view of the latch assembly of Fig. 1.

Fig. 4 is a right side rear perspective view of the latch of Fig. 1 shown in the closed position.

20 Fig. 5a is a front elevation view showing the latch of Fig. in an installed condition.

Fig. 5b is a left rear perspective view of the handle of the latch shown in Fig. 5a.

25 Fig. 6a is a front elevation view of the latch according to the present invention in an installed condition, with an alternate handle embodiment.

Fig. 6b is left rear perspective view of the handle of the latch shown in Fig. 6a.

30 Fig. 7 is a right rear perspective view of an alternate embodiment of the latch assembly of Fig. 1 showing the latch assembly having an offset paddle with locking means in the closed position.

Fig. 8 is a left front perspective view of the pawl of the latch assembly of Fig. 1.

35 Fig. 9 is a right side perspective view of the pawl torsional spring of the latch assembly of Fig. 1.

Fig. 10 is a front elevation view of an alternate embodiment of a latch according to the present invention.

Fig. 11 is a rear elevation view of the latch assembly of Fig. 10.

Fig. 12 is a top plan view of the latch assembly shown in Figs. 10 and 11.

5 Fig. 13 is a rear elevation view of the locking member of the latch assembly shown in Figs. 10 through 12.

Fig. 14 is a front elevation view of a latch assembly according to Figs. 10 through 13 shown with an alternate handle embodiment.

10 Fig. 15 is a right rear perspective view of the handle of the latch assembly shown in Fig. 14.

DETAILED DESCRIPTION OF THE PREFERRED EMBODIMENTS

Referring to Fig. 1, a ratcheting pawl latch 10 is shown having an actuating member, such as, for example, the handle or paddle 11 which is pivotally mounted to a latch housing 12. The paddle 11 is attached to the housing in accordance with arrows "a" and snaps into the housing 12. The housing 12 is provided with means for accommodating the handle 11 to allow the handle 11 to rotate over a predetermined range when installed. The handle accommodating means is shown comprising flanges 13 and 14 which have projections thereon, respectively 15 and 16. The paddle or handle 11 is preferably provided with suitable means for attachment to the housing such as pintels, raised bosses or the like. Preferably mounting flanges 17, 18 are provided on opposite handle sides having slots 19, 20 therein respectively (Fig. 5b), for attachment to, the projections 15, 16 (Fig. 1) of the housing flanges 13, 14. While a snap-fit handle attachment means is shown in the embodiment of Fig. 1 it is conceivable that other fastening means such as a pins, axles, bearings, and the like can also be employed.

35 The housing 12 is shown in Fig. 1 provided with a lock holding means comprising the lock plug socket 22 having a generally cylindrical bore for receipt of a lock plug 23, which may be optionally provided with the assembly as shown

in Figs. 2, 4 and 7. The housing 12 is provided with a body portion 24 from which the flanges 13 and 14 extend. A flange 25 is provided on the top of the housing body 24. The flange 25 extends rearwardly from the housing body portion 24 and is vertically disposed and terminates into an arm portion which is generally perpendicular to the housing body 24. A first slot 26 is provided within the flange 25 and extends through the rear of the housing body 24 (as shown in the rear view of Fig. 2). The first slot 26 thereby forms a generally L-shaped configuration. A second slot 27 is provided below the vertical component of the first slot 26 and preferably communicates with the first slot 26. The second slot 27 extends through the housing body 24, and is generally perpendicular in relation to the first slot 26, as shown in the rear perspective view of the latch assembly of Fig. 2.

The latch assembly 10 also includes a pawl 28 shown pivotally connected to the latch housing 12 with suitable attachment means such as the pawl pivot members 29,30 which are provided extending outwardly from the pawl 28 at opposite sides thereof. The pivot members 29, 30 can also be provided as a single pivot member extending through the pawl 28. A pair of annular portions 31 are provided on the pawl pivot members 29,30. The annular portions 31 may be provided integral with the pawl pivot members 29,30 or can be separately provided in the form of rings or washer members which can be provided on the pawl pivot member 29,30. The annular portions 31 facilitate centering of the pawl 28 within the housing 12 in the centering slots 45a,45b provided in the housing 12 (Fig. 1). The pawl 28 is installed onto the housing 12 by snap-fit placement of the pawl pivot members 29,30 into the pawl pivot recesses 32,33 disposed in the housing 12. A pair of guide slots 34,35 is provided on the housing leading from the edge of the housing to the pawl pivot recesses 32,33 for guiding the pawl pivot members 29,30, in the direction of arrow "b" into the pawl pivot recesses 34,35.

As shown in Fig. 1, the pawl 28 is provided having a body portion 36 with a pair of pawl pivot members 29,30 extending therefrom. The pawl 28 has a locking engagement portion 37 and is provided with a pawl slot 38 to retain the keeper member 100 shown in Fig. 3. Preferably the keeper member 100 is attached to the stationary panel or compartment (not shown) at a position such that when the swinging panel to which the latch assembly 10 is attached is rotated to engage the keeper member 100, the keeper member 100 will be below the arm portion of the upper flange 25 for engagement with the pawl 28. The pawl 28 is also shown having an arm portion 39 extending from the pawl body 36. A pawl torsional spring 40 is shown installed on the pawl 28, and having downwardly extending tail portions 41,42 and arms 43,44 extending vertically therefrom. The vertical spring arms 43,44 extend from the respective coil portions 46 of the torsional spring 40 and connect to form a slot 47 for receiving the pawl arm 39 therein for engagement therewith.

The paddle 11 in Fig. 1 is shown having an actuation arm 48 extending rearwardly therefrom and a paddle retaining pin 49 extending rearwardly therefrom. Extending from the housing body 24 is a spring retaining socket 50 which is disposed in the area of the paddle retaining pin 49. A paddle compression spring 51 is installed on the retaining pin 49 and is held in part by the socket 50, as shown by arrow "c." The spring 51 provides a bias when the handle 11 is lifted so that after actuation takes place the handle 11 is returned to its original position by the force of the compression spring 51.

As shown in Fig. 2, the actuation arm 48 of the paddle 11 is provided to engage the engaging end 52 of the spring locking member 53 (Fig. 1). The spring locking member 53 is provided to extend through the lateral second slot 27 disposed in the lower portion of the housing 12. At the opposite end of the paddle engaging end 52 of the spring locking member 53 is the retaining portion 54 which is shown having a slot 55 provided therein for accommodating a

locking pin 56 of a lock plug 23 which is disposed within the lock socket 22. The spring locking member 53 is preferably comprised of a spring steel composition or plastic composition such as for example acetal, or any suitable like flexible member which is also durable enough to withstand the forces of actuation of the latch assembly.

In addition, the retaining portion 54 of the locking member 53 is provided with a positioning tab 59 which engages a positioning stop 58 on the housing 12. This facilitates alignment of the locking pin 56 within the slot 55, by maintaining the locking member 53 in a desired position (see Fig. 4).

The positioning stop 58 is shown comprising a detent 58a which extends downward in relation to the positioning tab 59. The positioning tab 59 is preferably provided as a spring member for deflection by the positioning stop 58 as the locking member 53 is slidably moved in parallel relation in the horizontal direction shown by the path of double arrow "d", from one side to the other of the positioning stop 58. This is accomplished by the selective engagement of the lock plug pin 56 by the user with a key or other operating device. As shown in Fig. 4, the latch 10 is in the unlocked position with the paddle engaging portion 52 of the locking member 53 seen positioned below the actuation arm 48 or the paddle 11 for selective engagement therewith when the paddle 11 is drawn forward. Referring to Fig. 4, in order to lock the assembly, the lock pin 56 is rotated to slide the locking member 53 to the right in the direction of arrow "d" to draw the paddle engaging portion 52 of the locking member 53 out of the reach of the paddle actuation arm 48. In the locked position, while not shown, the positioning tab 59 will be caused to be moved to the right of the positioning stop 58 by the movement of the lock pin 56 and will thus prevent the paddle engaging portion 52 of the locking member 53 from being able to engage the paddle actuation arm 48 when the paddle 11 is lifted.

The spring locking member 53 is also provided with a

pawl engaging portion 57 which engages the locking arm 37 of the pawl 28. The latch assembly 10 is actuated by lifting the paddle 11 in an upward direction (away from the surface to which the latch assembly 10 is mounted). The actuation arm 48 of the paddle 11 engages the paddle engaging portion 52 of the locking member 53 (Fig. 2) and the engaging portion 52 is lowered within the lateral second slot 27 of the housing 12. By actuating the locking member 53, it is lowered a distance such that the pawl engaging portion 57 of the locking member 53, which engages the pawl locking arm 37, is moved out of engagement with the pawl locking arm 37 thereby freeing up the pawl 28 for pivoting. The bias provided by the pawl torsional spring 40 releases the pawl 28 from its vertical (Fig. 1 and Fig. 3) position and allows the pawl 28 to rotate to disengage the keeper member 100, thereby opening the compartment or panel to which the latch assembly 10 is attached. The keeper member 100 is shown in Fig. 3 comprising a striker wire, but may comprise any like suitable member such as a bar, claw, or other suitable attachment member.

A notched portion 65 is shown in the back of the pawl 36 to provide clearance for the locking member 53, when the pawl 36 is released, as shown in Fig. 2. This facilitates the relief of stress upon the spring locking member 53 when the pawl is in its released (Fig. 2) position.

Suitable mounting means are provided to retain the latch assembly 10 on a panel or mounting surface. For example, installation of the latch assembly 10 to a panel may be accomplished with the mounting means shown in Fig. 2 comprising apertures 60,61,62 and guide pins 63,64 for facilitating the fastening of the latch assembly to a panel, such as for example, a glove box of an automobile.

An alternate embodiment of a latch assembly according to the present invention may be provided wherein the lock plug 21 (Fig. 1) is not employed. In such an embodiment, the handle utilized can be supplied without the lock aperture 70 of Figs. 5a, 5b.

Figs. 5a and 5b show the handle 11 of the present latch assembly 10 installed on a panel 300. The handle 11, is shown provided with a lock aperture 70 for allowing access to and exposing the lock plug 23 installed on the housing 12. The paddle boss 49 is provided to retain the paddle spring 51 (Figs. 1 and 4) between the handle 11 and the spring-retaining socket 50 of the housing 12. The paddle flanges 17,18 and slots 19,20 permit attachment to the housing 12 as previously described above. As shown in Fig. 5b, apertures 74,75 are disposed in the flanges 17,18 at the end of the slots 19,20 for retention of the housing projections 15,16 (Fig. 1).

The handle 11 of the latch assembly 10 may optionally be provided having multiple-piece construction, as shown in Figs. 6a and 6b, wherein the handle 311 is provided to extend over a portion of the housing 12, but not over the lock plug 23. In this embodiment, a trim plate 319 is provided to cover the area surrounding the lock plug 23. The trim plate 319 is shown having an aperture therein 370 for permitting access to the lock plug 23. The trim plate 319 is also provided with suitable mounting means for attachment to the housing 12. The mounting means are shown in Fig. 6b comprising a plurality of flange members 323 extending outwardly from the trim plate 319. While not shown, the trim plate can alternately be attached to the panel on which the latch is to be mounted with any suitable attachment means. In addition, the trim plate may be provided of varied sizes and dimensions including even a portion which underlies the bottom of the handle 311 to form a face plate.

Fig. 6b shows the means for connecting the paddle 311 to the housing 12. The paddle 311 comprises outwardly extending flange members 371,372 having slotted portions 376,377 therein which facilitate guiding the paddle over the housing projections 15,16 for installation of the projections 15,16 into the apertures 374,375 provided in the flange members respectively, 372,371 of the paddle 311.

Preferably, a connecting portion 373 is also provided for stability and retention, and is shown connecting the paddle flanges 371,372. The paddle 311 further includes an actuation arm 348 and a spring holding boss 349, for operation similar to that described above in relation with the paddle 11 of Figs. 1, 2, 4, 5a and 5b.

Referring to Fig. 7, an alternate embodiment of a latch assembly 210 according to the present invention is shown having an offset actuating mechanism. The actuating member 211 is provided at a distance from the housing body 212 and is shown having an extension member 209 which is connected to the paddle 211 for rotation with the paddle 211. A paddle mounting plate 213 is also provided to pivotally support the paddle 211. The extension member 209 extends from the paddle 211 to the housing and has an actuation arm 247 for selectively engaging the engaging portion 252 of the locking member 253 to lower the locking member 253 out of engagement with the locking arm of the pawl 226.

A lock socket 220 is provided with a lock cylinder 257 installed therein. The lock cylinder 257 is provided with a locking pin member 256 which selectively engages a loop 206 of a wire member 207 which is connected to the locking portion 254 of the locking member 253 to control movement thereof. While not shown, the wire member 207 may alternately be configured to actuate the locking member 253 as well.

Referring to Fig. 10, an alternate embodiment of a latch assembly 410 is shown according to the present invention. A paddle 411 is provided and is pivotally connected to a housing 412. A pawl 428 is pivotally installed in the housing through a pair of guide slots 434, 435 through which pawl pivot members 429, 430 are received, in the same manner as described above in connection with the embodiments shown in Figs. 1 through 9. The pawl 428 can be provided in the same manner as the pawl 28 shown in Figs. 1 through 4 and 8 and 9 above, and is installed and operates within the housing in the manner described above.

Fig. 11 is a rear view of the latch of Fig. 10 showing a spring locking member 453 installed within the housing 412. The locking member 453 is shown in Fig. 13 in an enlarged view. The engaging end or foot 452 of the locking member 453 is provided to be engaged by the paddle arm 448 (Fig. 11) when the latch 410 is actuated. The spring locking member 453 also includes a pawl engaging portion 457 which engages the locking arm 437 of the pawl 428. A retaining portion 454 is provided at one end of the locking member 453 and is held within the housing 412, as shown in Fig. 11. The pawl 428 and locking member 453 function in the manner described above in the embodiments shown in Figs. 1 through 9. When the latch 410 is actuated by lifting the handle 411 away from the housing the actuation arm 448 of the handle 411 depresses the engaging portion 452 of the locking member 453. The spring locking member 453 is thereby deflected by the actuation of the paddle 411 and the pawl 428 is then released from engagement with a keeper member, as discussed above.

Referring to Fig. 12, a compression spring 451 is shown disposed between the housing 412 and the paddle 411. The paddle compression spring 451 is held by a retaining pin 449 extending outwardly from the inside of the paddle 411. The opposite end of the compression spring 451 may be held in a socket 450 of the housing as described above in connection with the embodiment of Figs. 1 through 9. Fig. 12 shows the handle 411 being held on the housing 412 by a pair of mounting flanges 417, 418 extending outwardly from the handle on opposite ends thereof, each flange having a guide slot 419, 420, respectively, in which are disposed apertures, respectively, 421 and 422. The housing is provided with a pair of outwardly extending arms, 423, 424 which include projections, as described above and shown in connection with Figs. 1-9, which are received in the handle flange apertures 421, 422. The handle 411 is thereby pivotally connected to the housing 412.

An alternate embodiment of a latch assembly according

to the present invention is shown in Fig. 14. The latch 510 is provided similar to that 410 described above and shown in Figs. 10 through 13 but with the paddle 511 having a larger dimension. The latch embodiment 510 permits push and pull
5 actuation of the latch assembly. The handle 511 can be pulled by gripping below the paddle and pulling it forward, or, alternately, can be actuated by depressing the upper portion of the paddle inwardly toward the housing 412.

Fig. 15 is a rear view of the paddle 511 of the latch
10 embodiment 510 shown in Fig. 14. The paddle 511 includes paddle flanges 517, 518 and slots 519, 520 which permit attachment to a housing, such as that 412 described above and shown in Figs. 10 through 13. The paddle flanges 517, 518 also contain apertures 574, 575, respectively, disposed
15 therein. A grip guard 580 is provided to prevent slippage of a user's fingers into the latch assembly when the latch is operated. The handle 511 also includes an actuation arm 548 which is provided to engage a locking member as described above in accordance with the latching and
20 unlatching operation.

It will be apparent to those skilled in the art that various modifications can be made to the ratcheting pawl latch invention without departing from the scope and spirit of the invention, and it is intended that the present
25 invention cover modifications and variations of the ratcheting pawl latch which are within the scope of the appended claims and their equivalents.

What is claimed is:

1. A latch assembly for securing a first panel to a second panel wherein said panels are movable in relation to each other and wherein at least one of said panels has a keeper member installed thereon, said latch assembly comprising:

- a) a pawl;
- b) a spring locking member;
- c) an actuating member; and
- 10 d) housing means for housing said pawl, said locking member and said actuating member in cooperating relation with each other for selective engagement and release of said latch assembly with said keeper member.

15 2. The latch assembly of claim 1, further comprising a pawl spring carried on said pawl for biasing said pawl to retract from engagement with the keeper member when the locking member disengages the pawl.

20 3. The latch assembly of claim 2, wherein said pawl includes pivot means for rotatably mounting said pawl to said housing.

4. The latch assembly of claim 3, further comprising means for mounting said latch to a panel.

25 5. The latch assembly of claim 1, wherein the actuating member further comprises a member pivotally connected to said housing means and being pivotable by lifting or pressing said pivotally connected member.

30 6. The latch assembly of claim 5, wherein said locking member comprises a spring steel member.

7. The latch assembly of claim 1, wherein said locking member is provided with an engaging portion at one end thereof and a locking portion at the other end thereof, said locking portion including a slot disposed therein.

35 8. The latch assembly of claim 7, further comprising locking means for locking said locking member against engagement by the actuation member.

9. The latch assembly of claim 8, wherein said locking means comprises a socket provided in said housing, and a lock cylinder which is installed in said socket, said lock cylinder having a pin member which is selectively retractable for selective engagement with the slot of the locking portion of said locking member.

10. The latch assembly of claim 1, further comprising a spring member provided between the actuation member and the housing.

11. The latch assembly of claim 1, further comprising stress relief means for relieving stress on said locking member when said pawl is released from said keeper member.

12. The latch assembly of claim 11, wherein said pawl further comprises a recessed portion for accommodating said locking member upon release of the pawl from said keeper member.

13. A latch assembly for securing a first panel to a second panel wherein at least one of said first panel and said second panel is movable in relation to the other of said first panel and said second panel and wherein at least one of said first panel and said second panel has a keeper member installed thereon, said latch assembly comprising:

- a) a housing with attachment means for attachment to one of said panels;
- b) a pawl rotatably mounted in said housing;
- c) a locking member supported on said housing for selectively locking said pawl in position to engage the keeper member and releasing said pawl to disengage the keeper member therefrom, said locking member comprising a resilient member; and
- d) an actuating member pivotally mounted on said housing and including an arm for engagement with said locking member to selectively release the locking member from engagement with said pawl and

thereby release the pawl from engagement with the keeper member.

14. The latch assembly of claim 13, further comprising a pawl spring carried on said pawl for biasing said pawl to retract from engagement with the keeper member when the locking member disengages the pawl.

15. The latch assembly of claim 14, wherein said pawl includes pivot means for rotatably mounting said pawl to said housing.

16. The latch assembly of claim 15, further comprising means for mounting said latch to a panel.

17. The latch assembly of claim 13, wherein said locking member comprises a flexible member.

18. The latch assembly of claim 17, wherein said locking member comprises a spring steel member.

19. The latch assembly of claim 13, wherein said locking member is provided with an engaging portion at one end thereof and a locking portion at the other end thereof, said locking portion including a slot disposed therein.

20. The latch assembly of claim 19, further comprising locking means for locking said locking member against engagement by the actuation member.

21. The latch assembly of claim 20, wherein said locking means comprises a socket provided in said housing, and a lock cylinder which is installed in said socket, said lock cylinder having a pin member which is selectively retractable for selective engagement with the slot of the locking portion of said locking member.

22. The latch assembly of claim 13, further comprising a spring member provided between the actuation member and the housing.

23. The latch assembly of claim 13, wherein said pawl further comprises a recessed portion for accommodating said locking member upon disengagement of the pawl with said keeper member.

24. The latch assembly of claim 1, wherein the actuating member further comprises a member pivotally

connected to said housing means and being pivotable by lifting or pressing said pivotally connected member

25. A latch assembly for securing a first panel to a second panel wherein at least one of said first panel and said second panel is movable in relation to the other of said first panel and said second panel and wherein at least one of said first panel and said second panel has a keeper member installed thereon, said latch assembly comprising:

- a) a pawl member having a pawl body with pivot members extending outwardly in opposite directions therefrom;
- b) a paddle;
- c) a housing having attachment means for attachment to said movable panel, a first slot disposed in said housing for accommodating a pawl member as it is rotated by the actuation of the paddle; a second slot disposed in substantially perpendicular relation to the first slot; and a locking flange through which said first slot extends;
- d) a spring locking member carried by the housing and extending through the second slot of the housing;
- e) wherein said pawl member is rotatably mounted on said housing for pivotal movement through said first slot between locked and unlocked positions;
- f) wherein said paddle is pivotally mounted on said housing and includes an actuation arm for engagement with said spring locking member; and
- g) wherein said spring locking member engages said pawl member, and wherein said actuation arm is selectively engagable with said spring locking member to depress said locking member

for release of said pawl from its locked position.

26. A latch assembly for securing a first panel to a second panel wherein at least one of said first panel and said second panel is movable in relation to the other of said first panel and said second panel and wherein at least one of said first panel and said second panel has a keeper member installed thereon, said latch assembly comprising:

- a) a housing having attachment means for attachment to one or the other of said first and second panels;
- b) a pawl rotatably mounted on said housing;
- c) a locking member supported on said housing for selectively locking said pawl in position to engage the keeper member and releasing said pawl to disengage the keeper member therefrom, said locking member comprising a resilient member;
- d) an actuating member pivotally mounted on a mounting member and having an extending arm connected thereto at one end thereof and having at the other end thereof an actuation arm for engagement with said locking member to selectively release the locking member from engagement with said pawl and thereby release the pawl from engagement with the keeper member.

27. The latch assembly of claim 26, further comprising a pawl spring carried on said pawl for biasing said pawl to retract from engagement with the keeper member when the locking member disengages the pawl.

28. The latch assembly of claim 26, wherein said pawl includes pivot means for rotatably mounting said pawl to said housing.

29. The latch assembly of claim 28, further comprising

means for mounting said latch to a panel.

30. The latch assembly of claim 26, wherein said locking member comprises a flexible member.

31. The latch assembly of claim 30, wherein said
5 locking member comprises a spring steel member.

32. The latch assembly of claim 26, wherein said locking member is provided with an engaging portion at one end thereof and a locking portion at the other end thereof, said locking portion including a slot disposed therein.

10 33. The latch assembly of claim 26, further comprising locking means for locking said locking member against engagement by the actuation member.

34. The latch assembly of claim 26, wherein the actuating member further comprises a member pivotally
15 connected to said housing means and being pivotable by lifting or pressing said pivotally connected member.

35. A latch assembly for securing a first panel to a second panel wherein at least one of said first panel and said second panel is movable in relation to the other of
20 said first panel and said second panel and wherein at least one of said first panel and said second panel has a keeper member installed thereon, said latch assembly comprising:

- 25 a) a pawl member having a pawl body with pivot members extending outwardly in opposite directions therefrom;
- b) a housing having attachment means for attachment to one of said first and second panels, a first slot disposed in said housing for accommodating a pawl
30 member as it is rotated by the actuation of the paddle; a second slot disposed in substantially perpendicular relation to the first slot; and a locking flange through which said first slot extends;
- 35 c) a spring locking member carried by the housing and extending through the second slot of the housing;

- d) a pawl member rotatably mounted on said housing for pivotal movement through said slot between locked and unlocked positions;
- 5 e) a handle pivotally mounted on said housing and including an actuation arm for engagement with said spring locking member;
- 10 f) a pawl spring carried on said pawl for biasing said pawl to retract from engagement with the keeper member when the locking member disengages the pawl;
- 15 g) wherein said spring locking member engages said pawl member, and wherein said actuation arm is selectively engagable with said spring locking member to depress said locking member for release of said pawl from its locked position;
- 20 h) wherein said pawl includes pivot means for rotatably mounting said pawl to said housing; and
- i) wherein said locking member comprises a flexible member.
- 25 36. The latch assembly of claim 35, wherein the actuating member further comprises a member pivotally connected to said housing means and being pivotable by lifting or pressing said pivotally connected member.
- 30 37. The latch assembly of claim 1, wherein said actuating member has an aperture therein.
- 35 38. The latch assembly of claim 9, further including a trim plate having an aperture therein and being disposed on the locking means for permitting access to said locking means through said trim plate aperture.
39. The latch assembly of claim 38, wherein said trim plate further includes one or more mounting flanges extending therefrom for attachment to said housing.

1/13

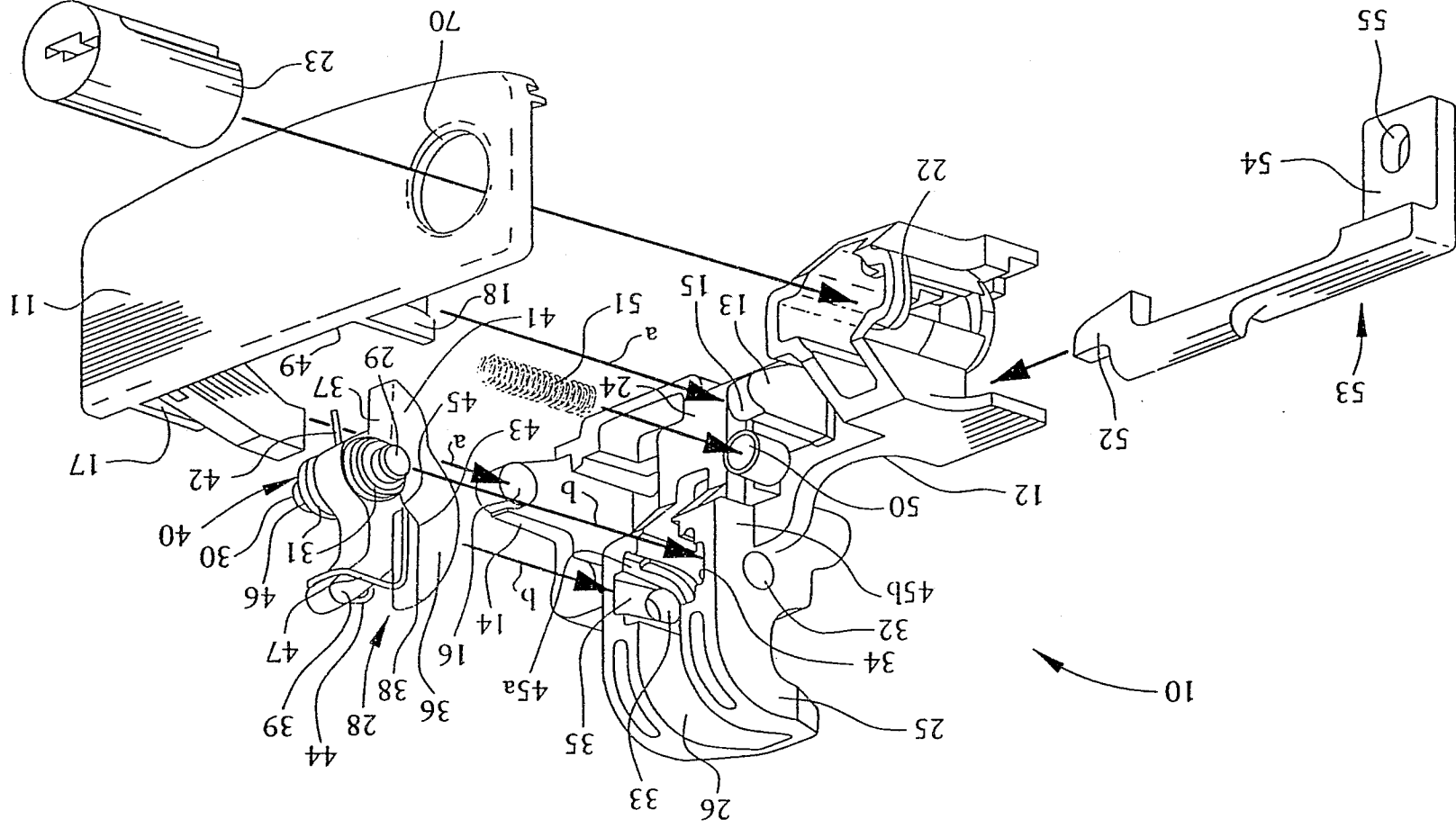

FIG. 1

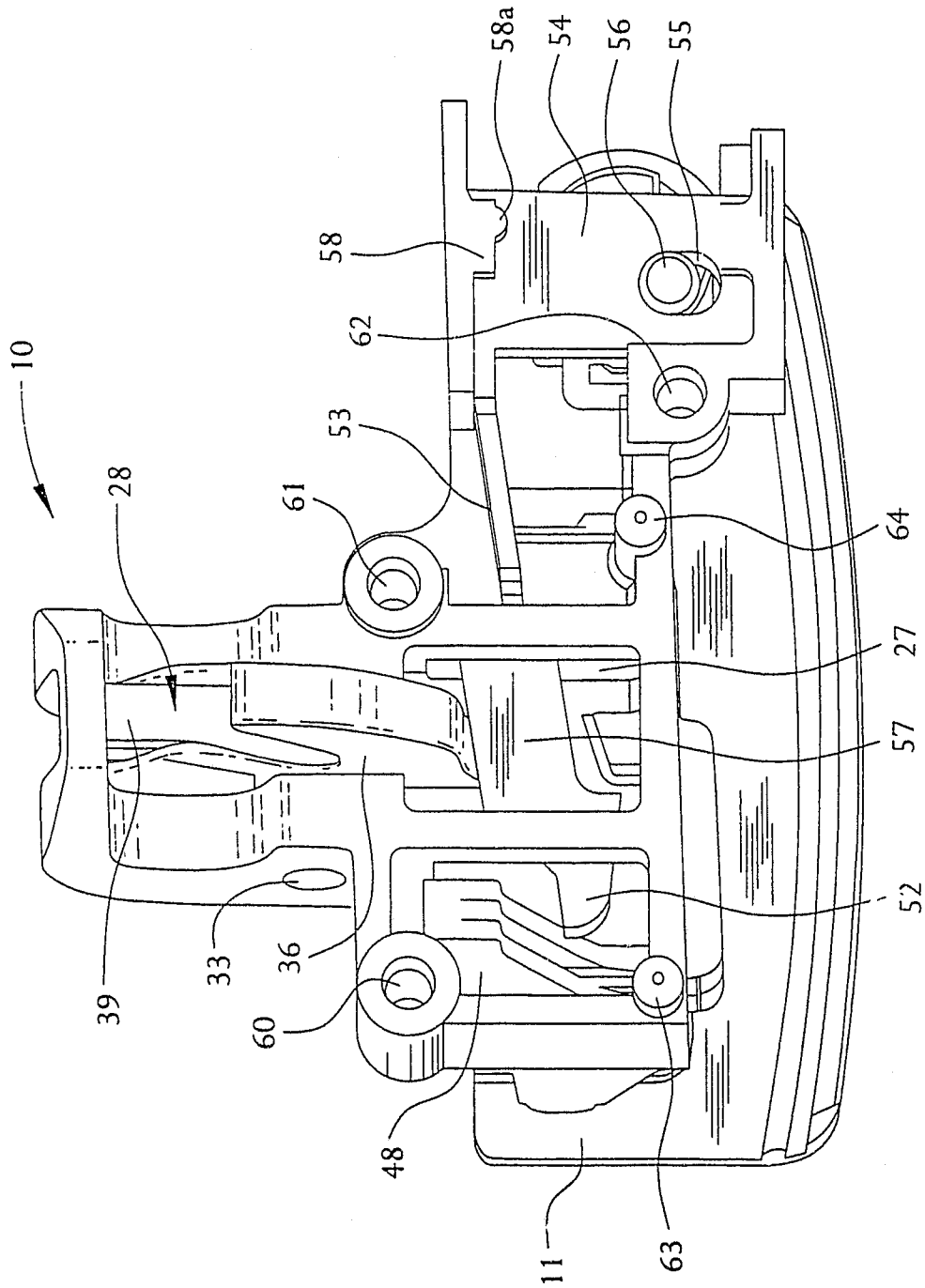

FIG. 2

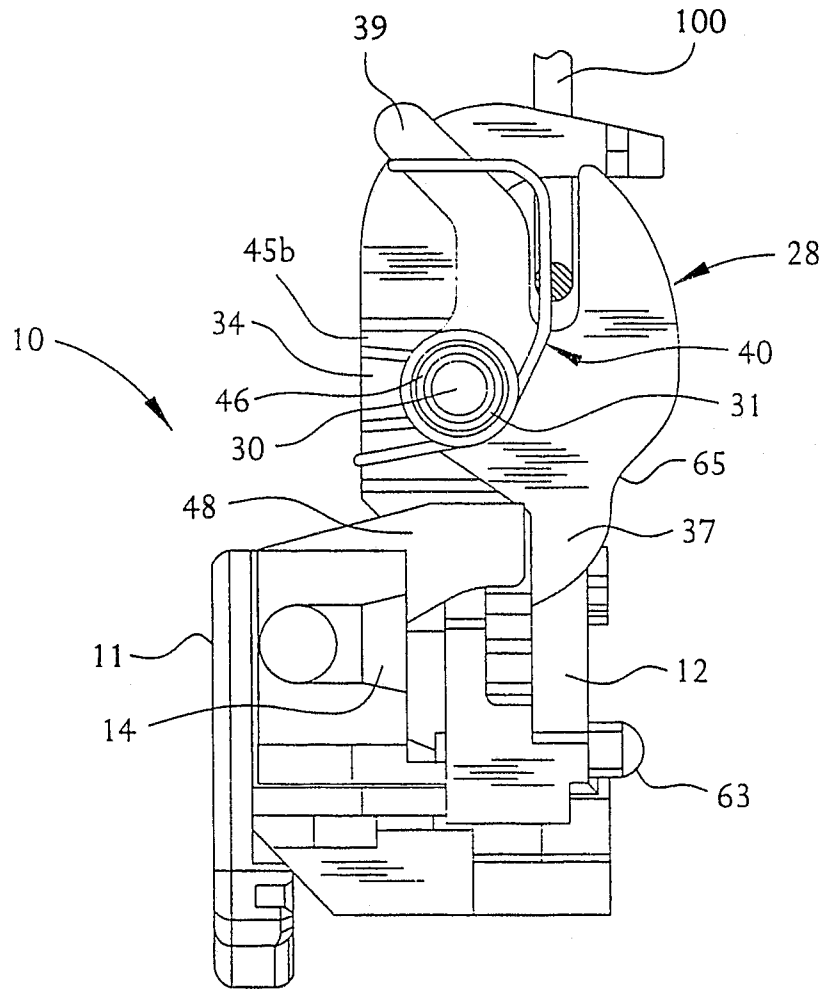

FIG. 3

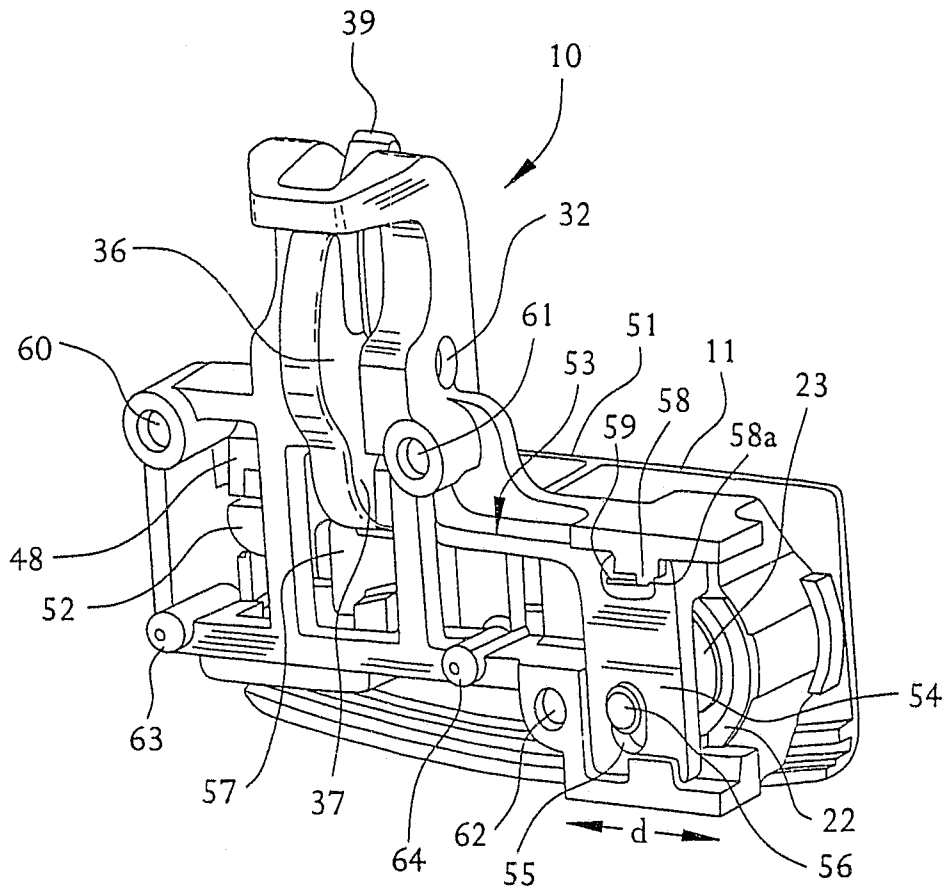

FIG. 4

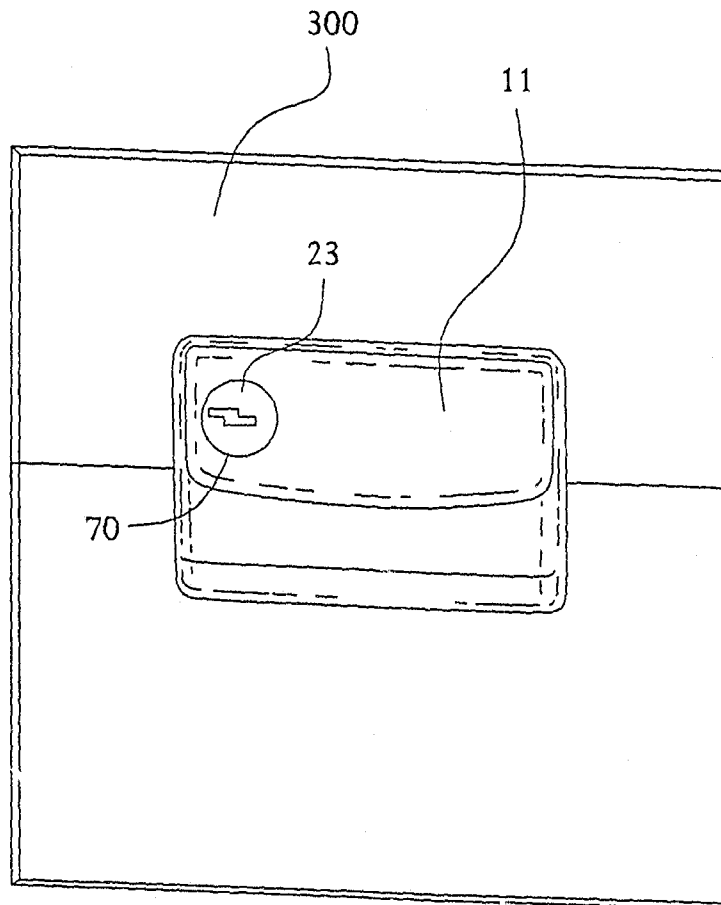

FIG. 5a

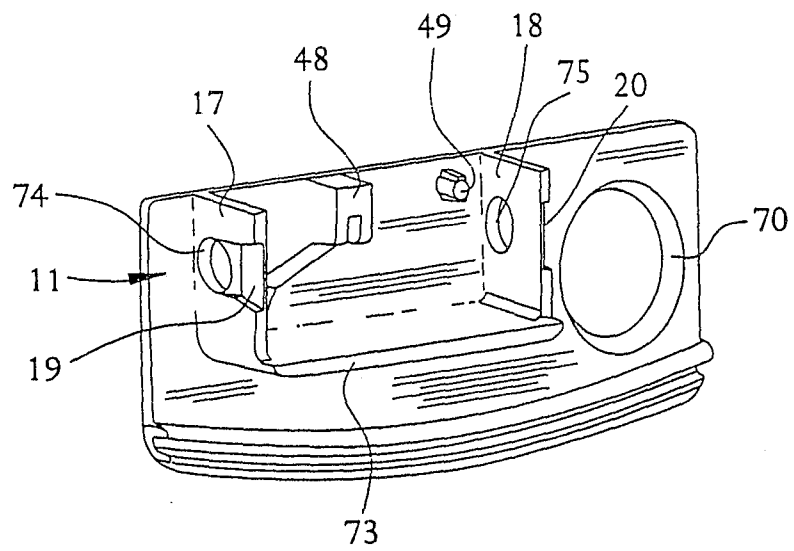

FIG. 5b

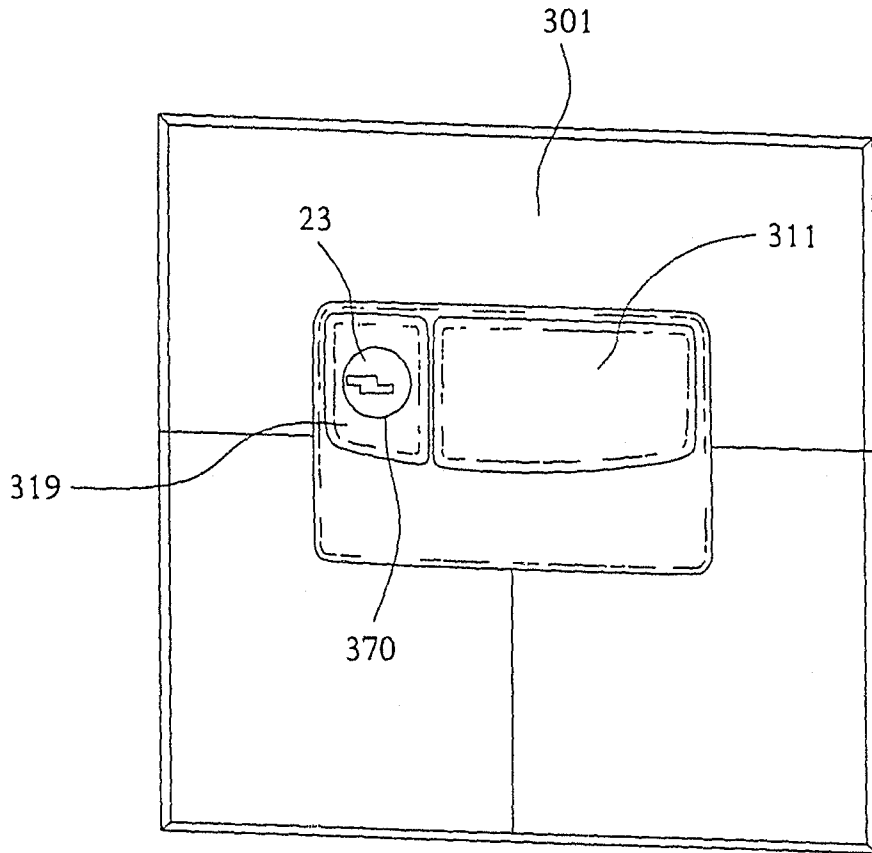

FIG. 6a

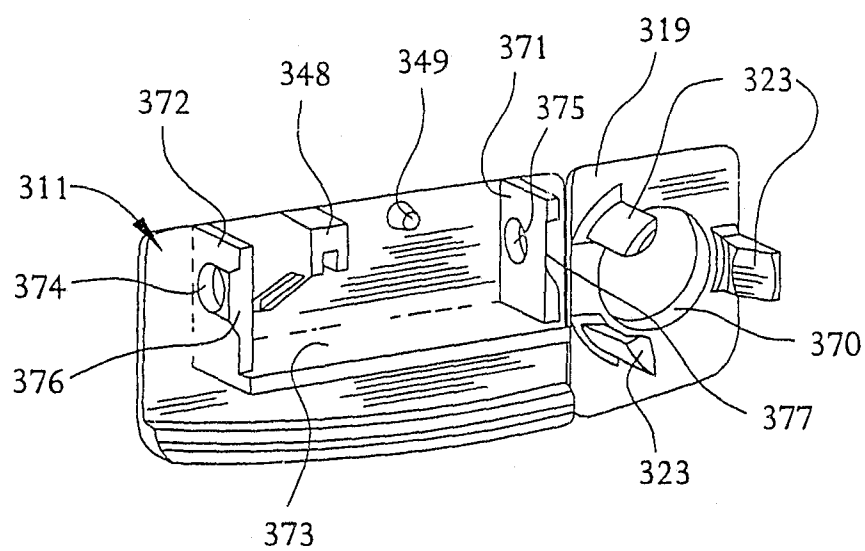

FIG. 6b

9/13

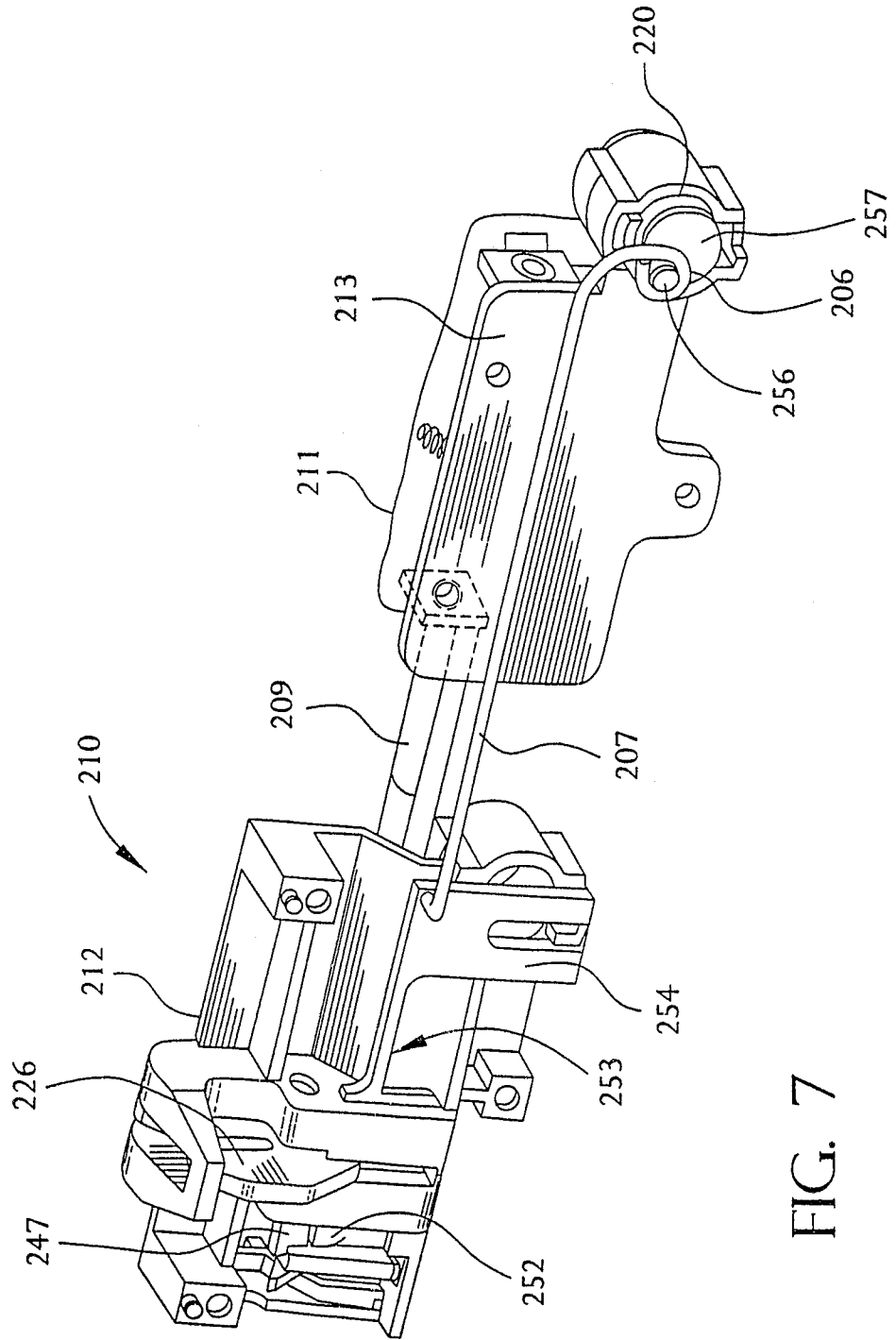

FIG. 7

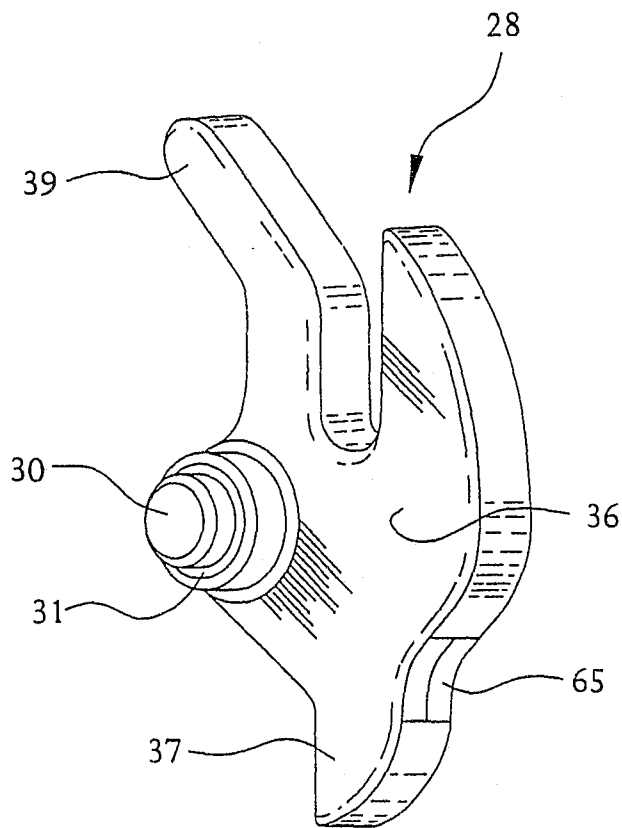

FIG. 8

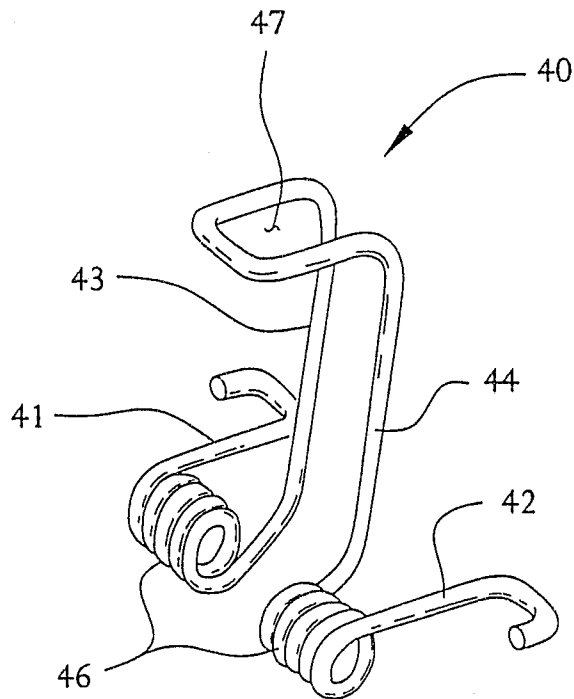

FIG. 9

12/13

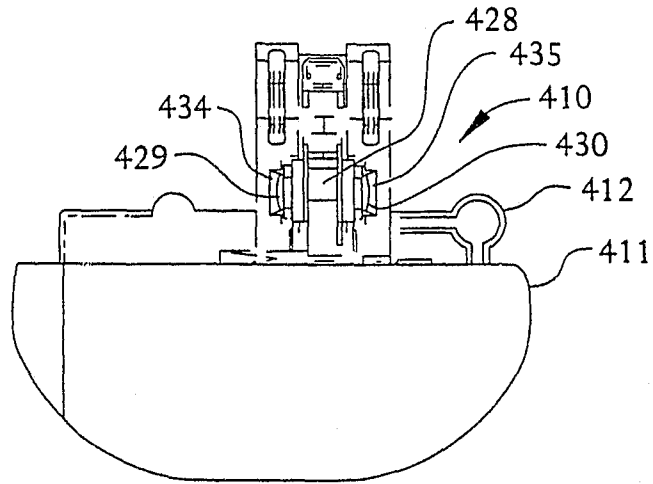

FIG. 10

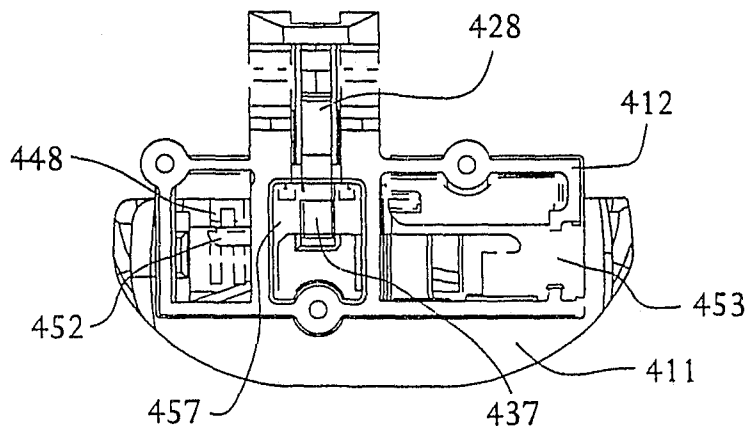

FIG. 11

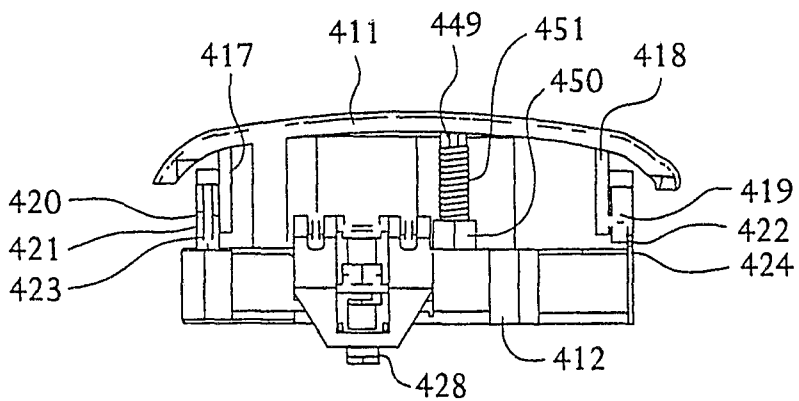

FIG. 12

13/13

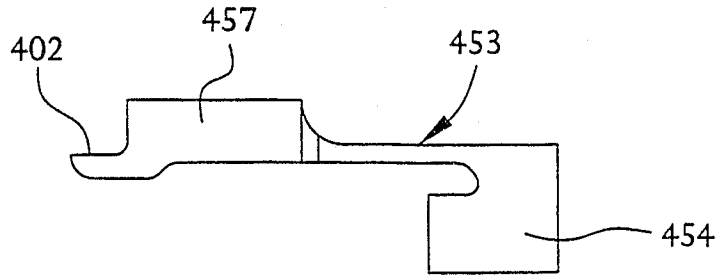

FIG. 13

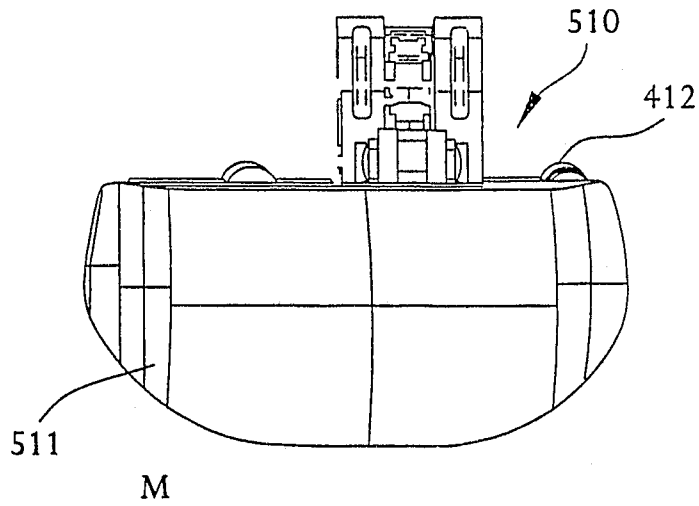

FIG. 14

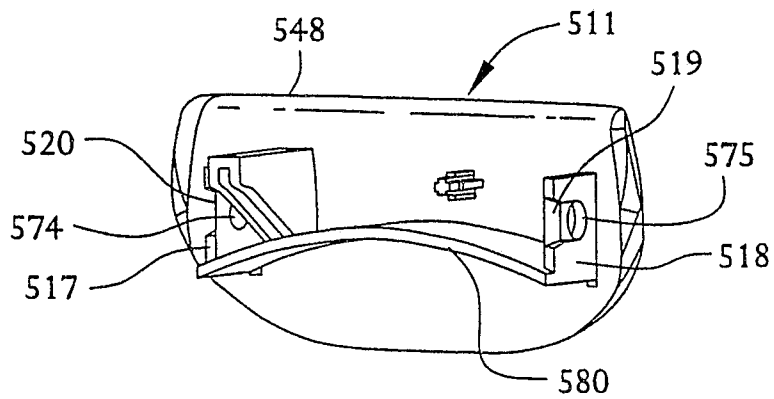

FIG. 15

INTERNATIONAL SEARCH REPORT

International application No.
PCT/US98/18990

A. CLASSIFICATION OF SUBJECT MATTER

IPC(6) :E05C 3/16
US CL .292/224

According to International Patent Classification (IPC) or to both national classification and IPC

B. FIELDS SEARCHED

Minimum documentation searched (classification system followed by classification symbols)

U.S. : 292/224,216,227; 70/208,210

Documentation searched other than minimum documentation to the extent that such documents are included in the fields searched

Electronic data base consulted during the international search (name of data base and, where practicable, search terms used)

C. DOCUMENTS CONSIDERED TO BE RELEVANT

Category*	Citation of document, with indication, where appropriate, of the relevant passages	Relevant to claim No.
X	US 4,969,916 A (WEINERMAN et al.) 13 November 1990 (13.11.,90), see entire document.	1-39
A	US 4,911,487 A (RACHOCKI) 27 March 1990 (27.03.90), see entire document.	1-39

Further documents are listed in the continuation of Box C. See patent family annex.

* Special categories of cited documents	*T* later document published after the international filing date or priority date and not in conflict with the application but cited to understand the principle or theory underlying the invention
A document defining the general state of the art which is not considered to be of particular relevance	*X* document of particular relevance, the claimed invention cannot be considered novel or cannot be considered to involve an inventive step when the document is taken alone
E earlier document published on or after the international filing date	*Y* document of particular relevance; the claimed invention cannot be considered to involve an inventive step when the document is combined with one or more other such documents, such combination being obvious to a person skilled in the art
L document which may throw doubts on priority claim(s) or which is cited to establish the publication date of another citation or other special reason (as specified)	*G* document member of the same patent family
O document referring to an oral disclosure, use, exhibition or other means	
P document published prior to the international filing date but later than the priority date claimed	

Date of the actual completion of the international search

26 OCTOBER 1998

Date of mailing of the international search report

16 DEC 1998

Name and mailing address of the ISA/US
Commissioner of Patents and Trademarks
Box PCT
Washington, D.C. 20231

Facsimile No. (703) 305-3230

Authorized officer

SUZANNE DINO BARRETT *Diane Smith*

Telephone No. (703) 308-0825