



(12) **United States Design Patent**
Duncan et al.

(10) **Patent No.:** **US D939,672 S**
(45) **Date of Patent:** **** Dec. 28, 2021**

(54) **COUPLING**

(71) Applicant: **Aalberts integrated piping systems Americas, Inc.**, Matthews, NC (US)

(72) Inventors: **Patrick W. Duncan**, Marshville, NC (US); **Daniel Foster**, Troutman, NC (US); **Jorden Hardzinski**, Peachland, NC (US); **Julie Howell**, Indian Trail, NC (US); **Matthew Williams**, Charlotte, NC (US); **Phillip Yontz**, Rock Hill, SC (US)

(73) Assignee: **Aalberts integrated piping systems APAC Inc.**, Pintung (TW)

(**) Term: **15 Years**

(21) Appl. No.: **29/747,367**

(22) Filed: **Aug. 21, 2020**

Related U.S. Application Data

(63) Continuation of application No. 16/852,989, filed on Apr. 20, 2020.

(51) **LOC (13) CI.** **23-01**

(52) **U.S. CI.**
USPC **D23/262**

(58) **Field of Classification Search**
USPC D23/259, 262-265; D8/394-396; 285/411
See application file for complete search history.

(56) **References Cited**

U.S. PATENT DOCUMENTS

29,731 A	8/1860	Truss
3,251,615 A	5/1966	Short, III
3,362,730 A	1/1968	Clair et al.
3,423,111 A	1/1969	Elsner
4,311,248 A	1/1982	Westerlund et al.

4,471,979 A	9/1984	Gibb et al.
4,702,499 A	10/1987	Deraymond et al.
5,207,459 A	5/1993	Glover
5,375,888 A	12/1994	Ikeda
5,904,325 A	5/1999	Hung
6,095,197 A	8/2000	Kane
6,170,884 B1 *	1/2001	McLennan F16L 17/04 285/112
6,227,577 B1	5/2001	Ikeda et al. (Continued)

FOREIGN PATENT DOCUMENTS

AR	095474 A1	10/2015
CN	2352801 Y	12/1999
		(Continued)

OTHER PUBLICATIONS

"A New Pipeline Connection Technology—A Hoop Connection, Chinese Academic Journal Electronic", vol. 164, Jun. 2000, 5 pages.
(Continued)

Primary Examiner — Amy C Wierenga

(57) **CLAIM**

The ornamental design for a coupling, as shown and described.

DESCRIPTION

FIG. 1 is a perspective view of a coupling;
FIG. 2 is a front view thereof;
FIG. 3 is a rear view thereof;
FIG. 4 is a right side view thereof;
FIG. 5 is a left side view thereof;
FIG. 6 is top plan view thereof; and,
FIG. 7 is a bottom plan view thereof.
The broken lines shown in the drawings illustrate portions of the coupling that form no part of the claim.

1 Claim, 5 Drawing Sheets

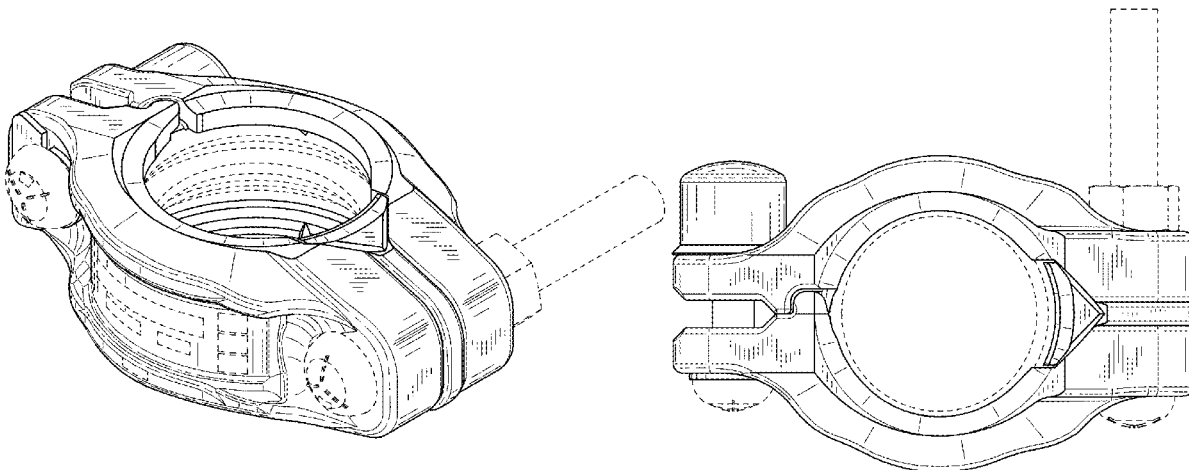

(56)

References Cited

U.S. PATENT DOCUMENTS

6,626,466	B1 *	9/2003	Dole	F16L 17/04 285/112
6,945,569	B1	9/2005	Diaz et al.	
7,086,131	B2	8/2006	Gibb et al.	
7,207,606	B2	4/2007	Owen et al.	
7,296,451	B2	11/2007	Dole	
D583,914	S *	12/2008	Pierce	D23/262
7,510,033	B2	3/2009	Lutzhoeft et al.	
7,516,636	B2 *	4/2009	Dole	B21D 17/04 72/105
D605,736	S *	12/2009	Porter	D23/262
7,665,773	B2	2/2010	Jones et al.	
7,712,796	B2	5/2010	Gibb et al.	
D629,072	S *	12/2010	Madara	D23/262
D629,074	S *	12/2010	Shah	D23/262
D629,078	S *	12/2010	Dole	D23/262
7,921,536	B2	4/2011	Dole	
7,950,701	B2	5/2011	Dole et al.	
8,177,263	B2	5/2012	Dole et al.	
8,282,136	B2	10/2012	Vandal et al.	
8,312,616	B2	11/2012	Dole et al.	
8,424,918	B2 *	4/2013	Gibb	F16L 21/065 285/112
8,517,430	B2	8/2013	Dole et al.	
8,550,502	B2	10/2013	Vandal et al.	
8,615,865	B2	12/2013	Vandal et al.	
8,621,741	B2	1/2014	Hagiya	
8,646,165	B2	2/2014	Gibb et al.	
8,646,814	B2 *	2/2014	Lippka	F16L 17/04 285/421
8,733,799	B2	5/2014	Gibb et al.	
RE45,304	E	12/2014	Dole et al.	
8,905,440	B2	12/2014	Hagiya	
8,979,138	B2	3/2015	Dole et al.	
9,239,123	B2	1/2016	Vandal et al.	
9,297,482	B2	3/2016	Vandal et al.	
9,500,307	B2	11/2016	Beagen, Jr.	
9,534,715	B2	1/2017	Beagen, Jr.	
9,726,310	B2	8/2017	Gibb et al.	
9,746,119	B2	8/2017	Hagiya	
9,770,796	B2	9/2017	Hagiya	
D819,435	S *	6/2018	Bancroft	D8/396
D820,074	S *	6/2018	Huettemann	D8/394
10,036,493	B2	7/2018	Vandal et al.	
10,047,885	B2	8/2018	Vandal et al.	
10,458,579	B2	10/2019	Bowman et al.	
10,627,025	B2	4/2020	Bowman et al.	
11,060,639	B2 *	7/2021	Cuvo	F16L 23/024
2002/0014772	A1	2/2002	Amedure et al.	
2002/0050363	A1	5/2002	Hagiya	
2011/0146049	A1	6/2011	Hagiya	
2011/0154646	A1	6/2011	Hagiya	
2014/0096361	A1	4/2014	Hagiya	
2015/0300549	A1	10/2015	Cheng-Sheng et al.	
2015/0345679	A1	12/2015	Hagiya	
2016/0040816	A1	2/2016	Cheng-Sheng et al.	
2017/0328500	A1	11/2017	Bowman et al.	

FOREIGN PATENT DOCUMENTS

CN	2374723	Y	4/2000
CN	2556454	Y	6/2003
CN	2597805	Y	1/2004
CN	1701196	A	11/2005
CN	1813150	A	8/2006
CN	1860323	A	11/2006
CN	1932363	A	3/2007
CN	201521732	U	7/2010
EP	0352018	A1	1/1990
EP	0398471	A1	11/1990
EP	0794379	A1	9/1997
EP	0926414	A2	6/1999
EP	2971924	A1	1/2016
GB	2189000	A	10/1987

GB	2229245	A	9/1990
GB	2355293	A	4/2001
JP	59-42389	U	3/1984
JP	62-30084	A	2/1987
JP	2003-42360	A	2/2003
TW	013650		9/1973
TW	069339		8/1985
TW	075044		2/1986
TW	093483		11/1987
TW	177610		1/1992
TW	233749		11/1994
TW	263044		11/1995
TW	302063	U	4/1997
TW	359735	B	6/1999
TW	360356	U	6/1999
TW	375232	U	11/1999
TW	383828	U	3/2000
TW	420269	U	1/2001
TW	453414	U	9/2001
TW	461945	B	11/2001
TW	463021	B	11/2001
TW	509302	U	11/2002
TW	521136	B	2/2003
TW	576136	U	2/2004
TW	M245346	U	10/2004
TW	I227310	B	2/2005
TW	200600711	A	1/2006
TW	200606365	A	2/2006
TW	200606366	A	2/2006
TW	200607947	A	3/2006
TW	200607948	A	3/2006
TW	200712366	A	4/2007
TW	M376675	U	3/2010
TW	201111671	A	4/2011
WO	2014/151076	A1	9/2014

OTHER PUBLICATIONS

File History of Reexam 90/012,060, filed Dec. 16, 2011 (now U.S. Pat. No. 7,950,701 C1, granted Sep. 4, 2012), 274 pages.

“File History of U.S. Appl. No. 13/415,086”, Dec. 30, 2014, 406 pages.

IPR2016-00276 (U.S. Pat. No. 8,733,799) *Tyco Fire Products LP v. Victaulic Co.*, 268 pages.

IPR2016-00278 (U.S. Pat. No. 8,646,165), *Tyco Fire Products LP v. Victaulic Co.*, 368 pages.

IPR2016-00279 (U.S. Pat. No. 8,646,165) *Tyco Fire Products LP v. Victaulic Co.*, 360 pages.

Pipeline Connection Sealing Device, Chinese Academic Journal Electronic, Sep. 2000, 2 pages.

Shurjoint Piping Products, 2006 General Catalog, 2006, 9 pages.

Shurjoint Piping Products General Catalog, 2005, 3 pages.

Shurjoint Product Catalog, 2018, 5 pages.

Tyco Fire Building Products, Grinnell Mechanical Products, 2008, 11 pages.

Tyco Fire Building Products, Grinnell 2007—Grooved Fire Protection Installation Manual, IH-1000FP, Aug. 2007, 11 pages.

Victaulic Brochure, 5 pages.

Victaulic Product Catalog (English Translation), 10 pages.

Victaulic, “Couplings and Fittings for JIS Pipe”, JIS Steel Pipe Grooved Couplings and Fittings, Jun. 17, 2002, 4 pages.

Victaulic, “Gasket Selection Guide”, Revised Jun. 2001, 3 pages.

Victaulic, “IPS Carbon Steel Pipe Grooved Couplings”, Apr. 6, 1999, 2 pages.

Victaulic, “Plain End Piping System for High Density Polyethylene Pipe”, IPS High Density Poly. Pipe—Plain End Pipin G System, Jan. 19, 1997, 1 page.

Victaulic, “Style 005 Firelock Rigid Coupling”, IPS Carbon Steel Pipe Fire Protection Products, Feb. 10, 1999, 2 pages.

Victaulic, “Style 22 Vic-Ring® Coupling”, Vic-Ring—Applied Ring System, Feb. 16, 2005, 2 pages.

Victaulic, “Style 44 Vic-Ring® Coupling”, Vic-Ring—Applied Ring System, May 16, 2005, 3 pages.

Victaulic, “Style 995 Coupling for HDPE Pipe”, IPS High Density Poly. Pipe—Plain End Piping System, Feb. 19, 2001, 2 pages.

(56)

References Cited

OTHER PUBLICATIONS

Victaulic Co. v., "Andrei Iancu 2017-2424, 2017-2426", Nov. 29, 2018, 11 pages.

Victaulic, "Anatomy of a Grooved Pipe Joint", Jan. 4, 2005, 4 pages.

Victaulic, "Coupling for Copper Tubing Style 606", CTS Copper Tubing—Grooved Couplings, Feb. 22, 2006, 4 pages.

Victaulic, "Roll Grooved Pipe Technical Data", Grooved Piping System—Design Data, Aug. 26, 2009, 4 pages.

* cited by examiner

FIG. 1

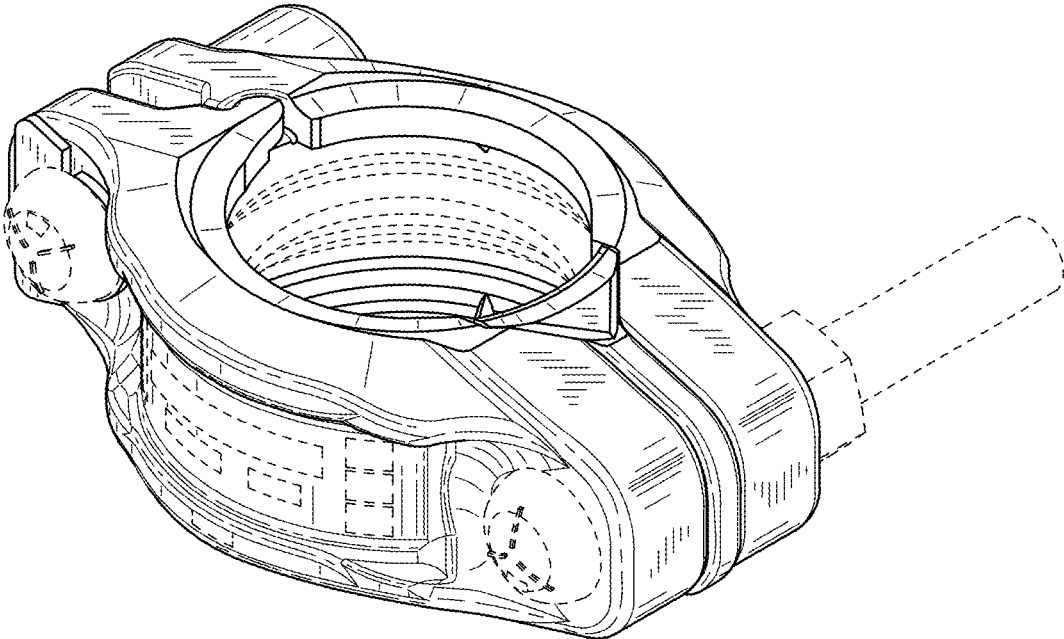

FIG. 2

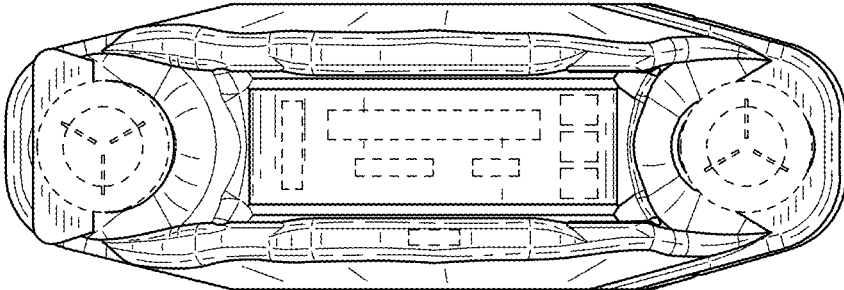

FIG. 3

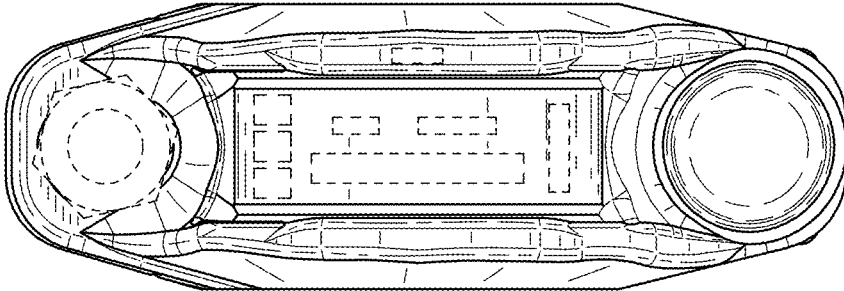

FIG. 4

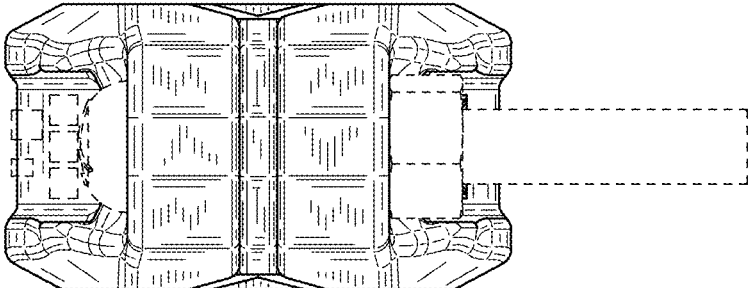

FIG. 5

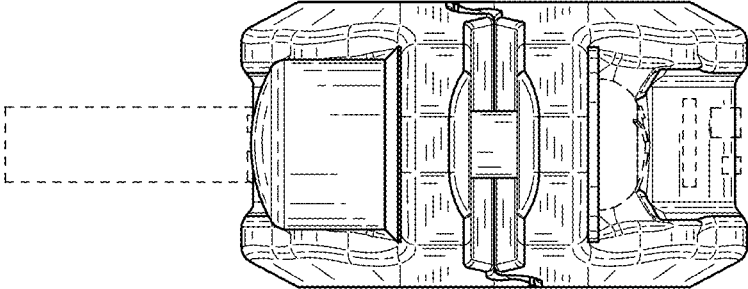

FIG. 6

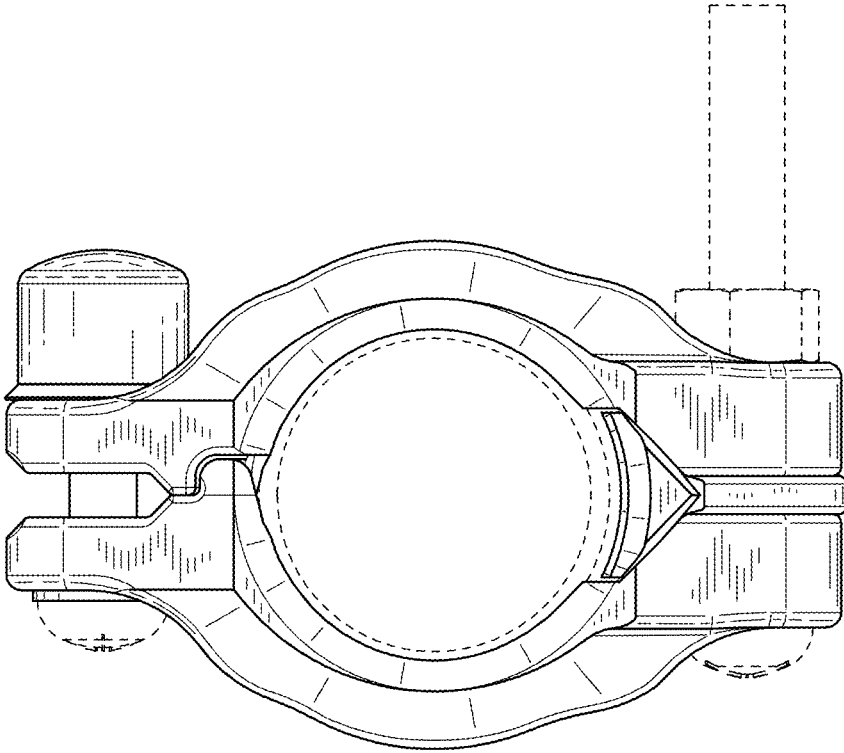

FIG. 7

